

ABB BALDOR RELIANCE III

Customer information packet

CFSWDM3554-E

1.5HP, 1770RPM, 3PH, 60HZ, 56C, 3526M, TEFC, F1

Class - None

Division - Not Applicable

Specifications

Enclosure	TEFC
Frame	56C
Frame Material	Stainless Steel
Frequency	60.00 Hz
Haz Area Class and Group	None
Haz Area Division	Not Applicable
Motor Letter Type	Three Phase
Output @ Frequency	1.500 HP @ 60 HZ
Phase	3
Synchronous Speed @ Frequency	1800 RPM @ 60 HZ
Voltage @ Frequency	230.0 V @ 60 HZ 460.0 V @ 60 HZ
Agency Approvals	CSA EEV CURUSEEV NEMA PREMIUM NEMA_PREMIUM WEEE
Ambient Temperature	40 °C
Auxiliary Box	NO AUXILLARY BOX
Auxiliary Box Lead Termination	None
Base Indicator	Rigid
Bearing Grease Type	Polyrex EM (-20F +300F)
Blower	None
Current @ Voltage	4.200 A @ 230.0 V 2.100 A @ 460.0 V
Design Code	B
Drip Cover	No Drip Cover
Duty Rating	CONT
Efficiency @ 100% Load	86.5 %
Electrically Isolated Bearing	Not Electrically Isolated
Feedback Device	NO FEEDBACK
Front Shaft Indicator	None

Part Detail

Revision	B
Type	AC
Mech. spec.	35E4741
Base	
Status	PRD/A
Elec. spec.	35WGZ819
Layout	35LYE4741
Eff. date	03-25-2025
CD Diagram	CD0005
Poles	04
Leads	9#18 Y
Proprietary	False
Created date	03-11-2022

Heater Indicator	No Heater
High Voltage Full Load Amps	2.1 a
Insulation Class	H
Inverter Code	Inverter Duty
KVA Code	M
Lifting Lugs	No Lifting Lugs
Locked Bearing Indicator	Locked Bearing
Max Speed	2700 rpm
Motor Finish	UNPAINTED
Motor Lead Quantity/Wire Size	9 @ 18 AWG
Motor Lead Termination	Flying Leads
Motor Standards	NEMA
Motor Type	3526M
Mounting Arrangement	F1
Number of Poles	4
Overall Length	13.96 IN
Power Factor	76
Product Family	WD All SD Non-Encapsulated
Pulley End Bearing Type	Sealed Bearing
Pulley Face Code	C-Face
Pulley Shaft Indicator	Standard
Rodent Screen	None
Service Factor	1.15
Shaft Diameter	0.625 IN
Shaft Ground Indicator	No Shaft Grounding
Shaft Rotation	Reversible
Shaft Slinger Indicator	No Slinger
Speed	1770 rpm
Speed Code	Single Speed
Starting Method	Direct on line
Thermal Device - Bearing	None
Thermal Device - Winding	None
Vibration Sensor Indicator	No Vibration Sensor
Winding Thermal 1	None

Winding Thermal 2

None

Nameplate

NP4427AAA01

CAT #	CFSWDM3554-E	WT		LBS	
SPEC	35E4741Z819G1	ENCL	TEFC		
SER #		CC	010A	IP	69
HP	1.5	MAG CUR	2.5/1.25		
VOLTS	230/460	NEMA NOM. EFF		86.5	
AMPS	4.2/2.1	PF	76		
RATING	40C AMB-CONT				
RPM	1770	MAX RPM	2700		
FRAME	56C	HZ	60	CODE	M
		CLASS	H		
SER.F.	1.15	SF AMP	4.7/2.35	PH	3
		DES	B		
DE	6205	ODE	6205		
LUBRICATION	POLYREX EM				
ID LOGO	INVERTER TYPE	VPWM	CHP	60	TO
				90	1.5:1
ID LOGO	WK2	0.189	CT	15	TO
				60	4:1
ID LOGO	SL HZ	1	VT	3	TO
				60	20:1
YR		QR			

ABB Motors and Mechanical Inc.

WINDING # 35WGZ819

Typical performance - not guaranteed values.

1.5 HP 3 PH 60 HZ 1770 RPM 460 V 3526M

TORQUES (LB-FT): PO=18.92 PU=9.99 LR=12.27 LRA=19.68

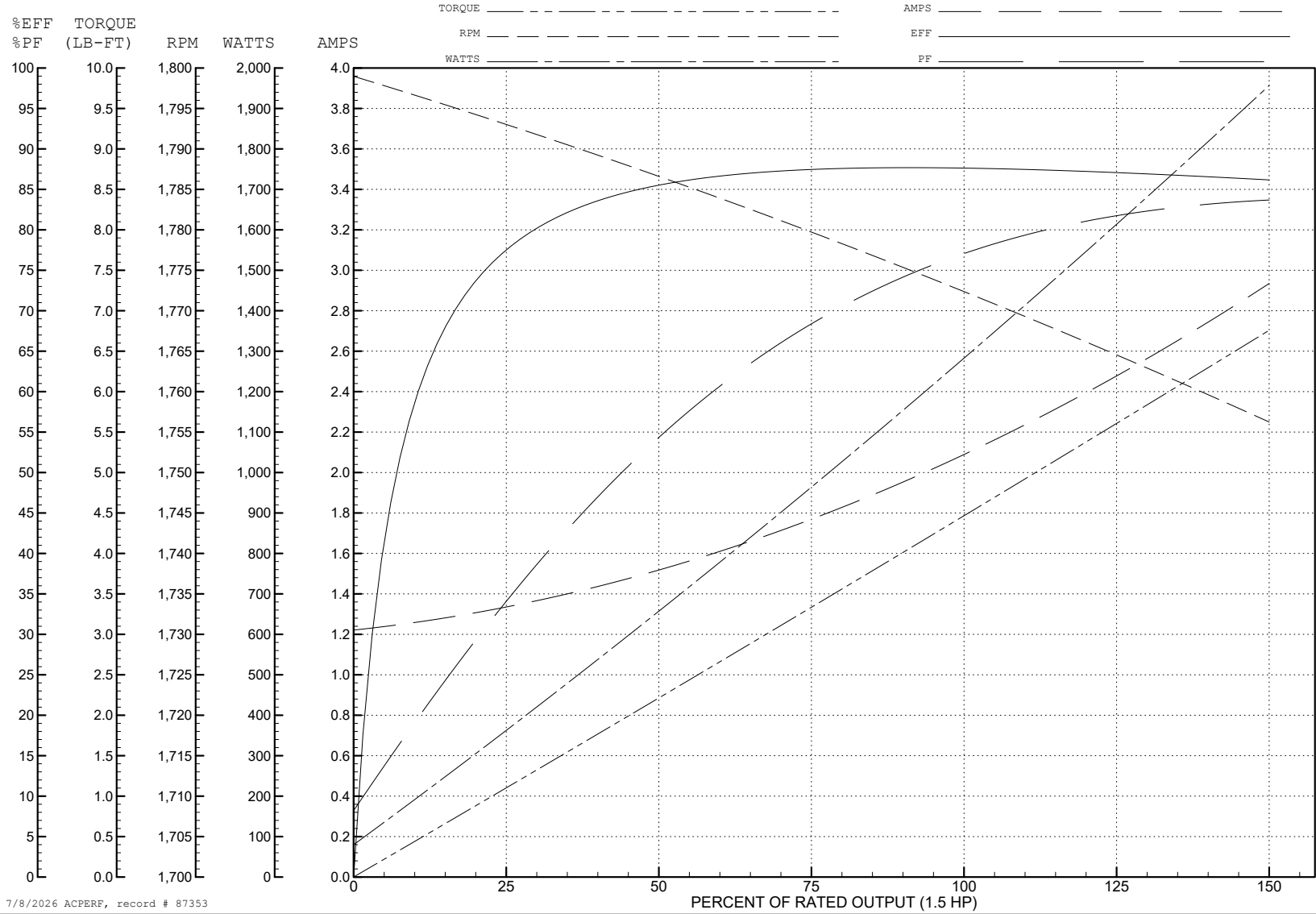

7/8/2026 ACPERF, record # 87353

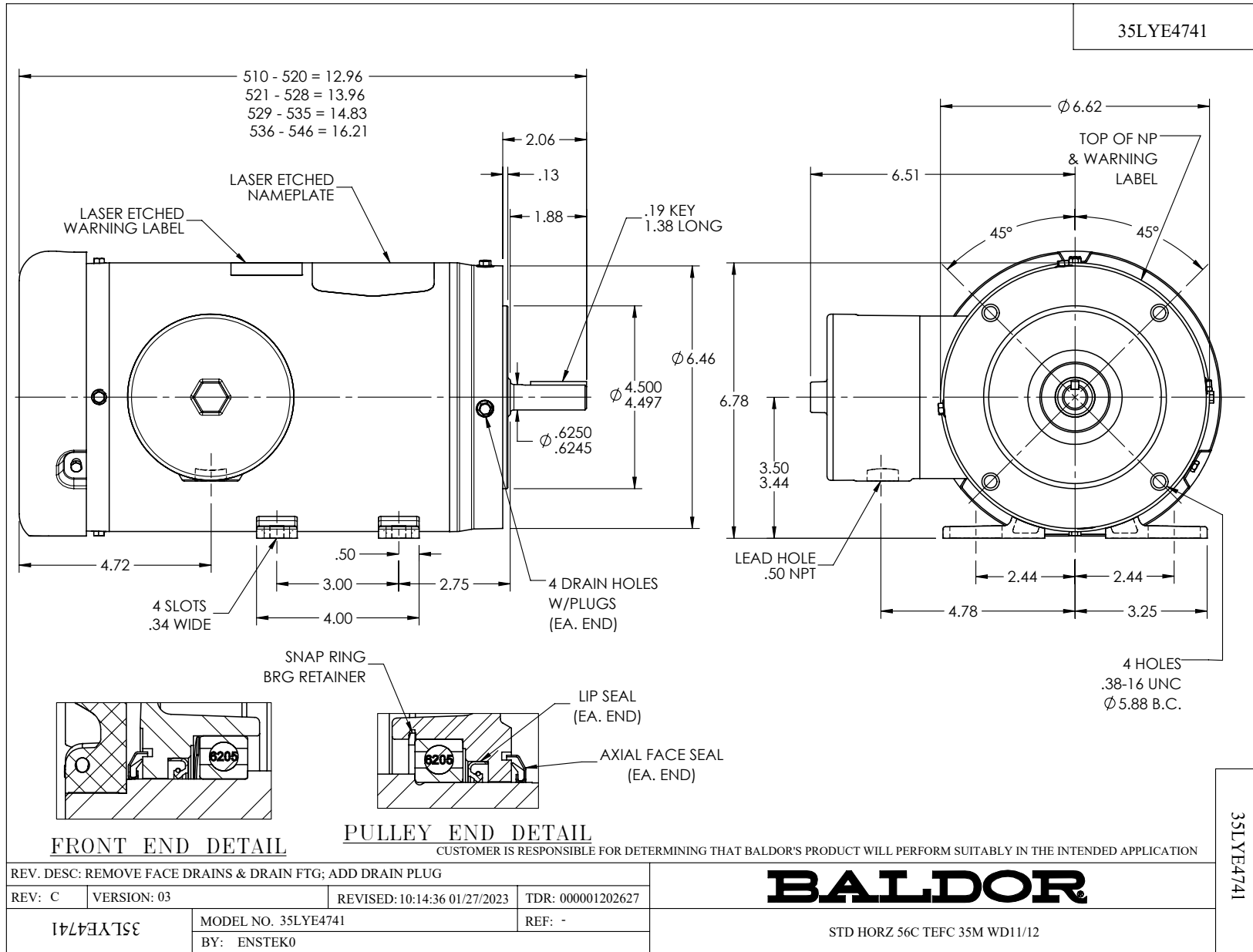

CD0005



LOW VOLTAGE
(2Y)



LINE

HIGH VOLTAGE
(1Y)

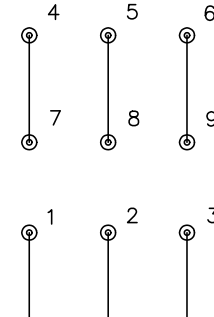

LINE

NOTES:

1. INTERCHANGE ANY TWO LINE LEADS TO REVERSE ROTATION.
2. OPTIONAL THERMOSTATS ARE PROVIDED WHEN SPECIFIED.
3. ACTUAL NUMBER OF INTERNAL PARALLEL CIRCUITS MAY BE A MULTIPLE OF THOSE SHOWN ABOVE.
4. LEAD COLORS ARE OPTIONAL. LEADS MUST ALWAYS BE NUMBERED AS SHOWN.

CD0005

REV. DESC: REVISE TO SHOW OPTIONAL COLORS

REV. LTR: E BY: JLP REVISED: 01/19/99 10:15 TDR: 0171435

900000

FILE: AAA00005140

MDL: -

MTL: -

BALDOR ELECTRIC Co.

3PH, DV, 9 LEADS