

ABB BALDOR RELIANCE III

Customer information packet

CFSWDM3550-4E

1.5HP, 3500RPM, 3PH, 60HZ, 56C, 3532M, TENV, F1

Class - None

Division - Not Applicable

Specifications

Enclosure	TENV
Frame	56C
Frame Material	Stainless Steel
Frequency	60.00 Hz
Haz Area Class and Group	None
Haz Area Division	Not Applicable
Motor Letter Type	Three Phase
Output @ Frequency	1.500 HP @ 60 HZ
Phase	3
Synchronous Speed @ Frequency	3600 RPM @ 60 HZ
Voltage @ Frequency	460.0 V @ 60 HZ
Agency Approvals	WEEE CURUSEEV NEMA PREMIUM
Ambient Temperature	40 °C
Auxiliary Box	NO AUXILLARY BOX
Auxiliary Box Lead Termination	None
Base Indicator	Rigid
Bearing Grease Type	Polyrex EM (-20F +300F)
Blower	None
Current @ Voltage	1.800 A @ 460.0 V
Design Code	B
Drip Cover	No Drip Cover
Duty Rating	CONT
Efficiency @ 100% Load	85.5 %
Electrically Isolated Bearing	Not Electrically Isolated
Feedback Device	NO FEEDBACK
Front Shaft Indicator	None
Heater Indicator	No Heater
High Voltage Full Load Amps	1.8 a
Insulation Class	H
Inverter Code	Inverter Duty

Part Detail

Revision	A
Type	AC
Mech. spec.	35E4735
Base	
Status	PRD/A
Elec. spec.	35WGK979
Layout	35LYE4735
Eff. date	09-13-2024
CD Diagram	CD0006
Poles	02
Leads	3#18
Proprietary	False
Created date	05-22-2024

KVA Code	M
Lifting Lugs	No Lifting Lugs
Locked Bearing Indicator	Locked Bearing
Max Speed	5400 rpm
Motor Finish	UNPAINTED
Motor Lead Quantity/Wire Size	3 @ 18 AWG
Motor Lead Termination	Flying Leads
Motor Standards	NEMA
Motor Type	3532M
Mounting Arrangement	F1
Number of Poles	2
Overall Length	13.67 IN
Power Factor	90
Product Family	WD All SD Non-Encapsulated
Pulley End Bearing Type	Sealed Bearing
Pulley Face Code	C-Face
Pulley Shaft Indicator	Standard
Rodent Screen	None
RoHS Status	Y
Service Factor	1.15
Shaft Diameter	0.625 IN
Shaft Ground Indicator	No Shaft Grounding
Shaft Rotation	Reversible
Shaft Slinger Indicator	No Slinger
Speed	3500 rpm
Speed Code	Single Speed
Starting Method	Direct on line
Thermal Device - Bearing	None
Thermal Device - Winding	None
Vibration Sensor Indicator	No Vibration Sensor
Winding Thermal 1	None
Winding Thermal 2	None

Nameplate

NP4427AAA02

CAT #	CFSWDM3550-4E	WGT		LBS	
SPEC	35E4735K979	ENCL	TENV		
SER #		CC	010A	IP	69
HP	1.5	MAG CUR	.65		
VOLTS	460	NEMA NOM. EFF		85.5	
AMPS	1.8	PF	90		
RATING	40C AMB-CONT				
RPM	3500	MAX RPM	5400		
FRAME	56C	HZ	60	CODE	M
		CLASS		H	
SER.F.	1.15	SF AMP		PH	3
		DES		B	
DE	6205	ODE	6205		
LUBRICATION	POLYREX EM				
ID LOGO	INVERTER TYPE	VPWM	CHP	60	TO
				90	1.5:1
ID LOGO	WK2	0.09	CT	15	TO
				60	4:1
ID LOGO	SL HZ	1.7	VT	3	TO
				60	20:1
YR				QR	

ABB Motors and Mechanical Inc.

WINDING # 35WGK979

Typical performance - not guaranteed values.

1.5 HP 3 PH 60 HZ 3500 RPM 460 V 3532M

TORQUES (LB-FT): PO=10.9 PU=5.2 LR=10.2 LRA=20.6

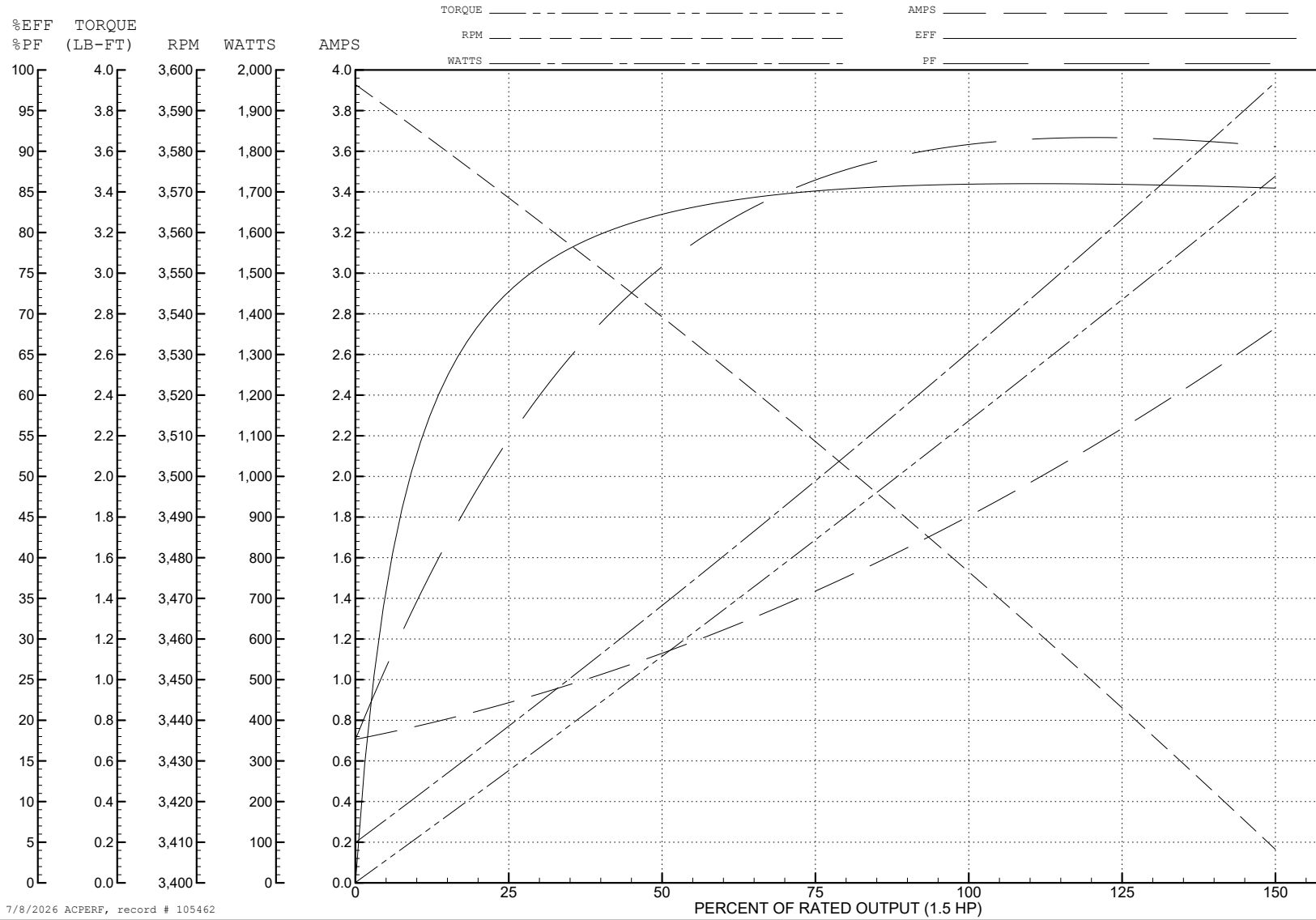

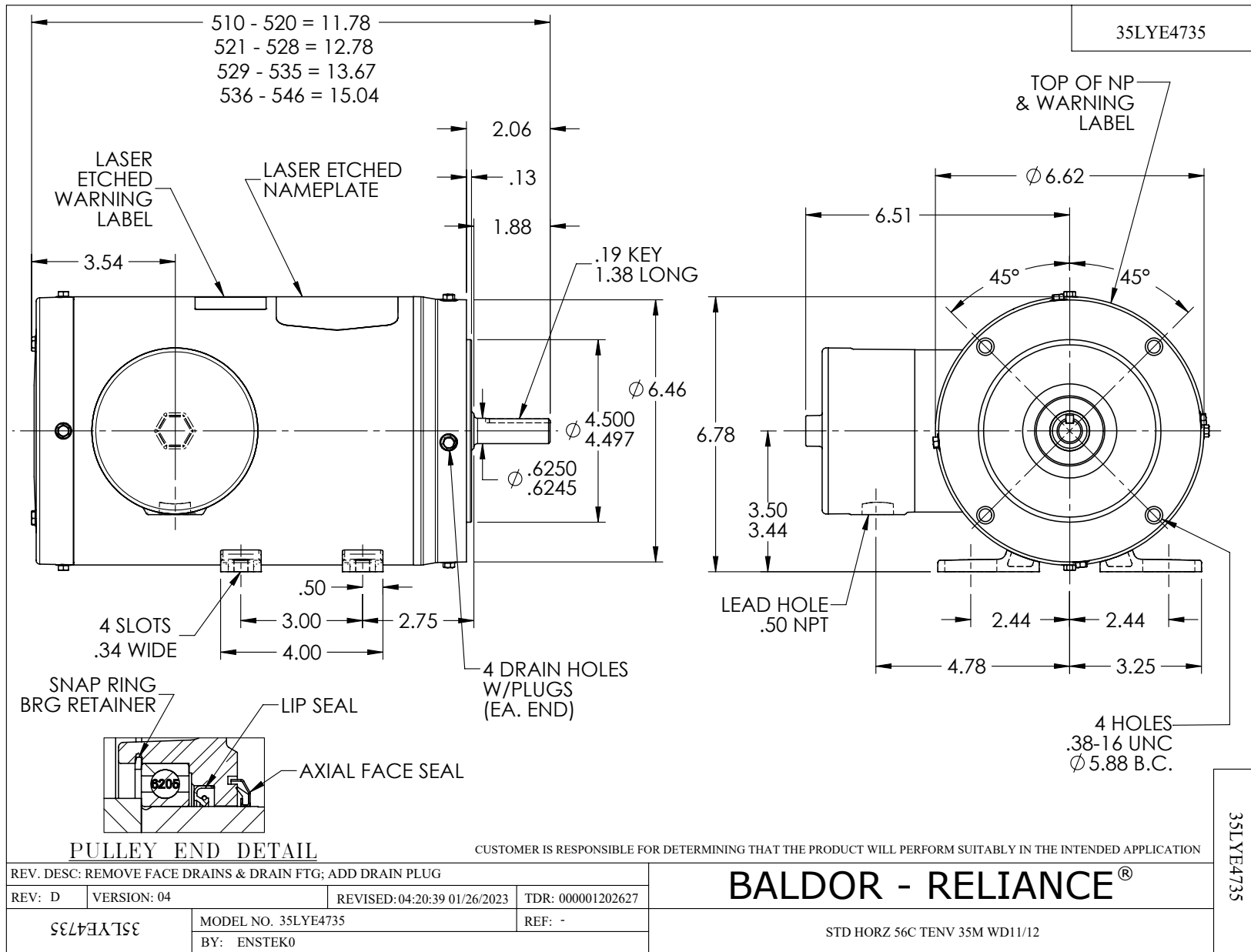

CD0006



NOTES:

1. THREE LEAD MOTOR MAY BE EITHER WYE CONNECTED OR DELTA CONNECTED.
2. INTERCHANGE ANY TWO LINE LEADS TO REVERSE ROTATION.
3. OPTIONAL THERMOSTATS ARE PROVIDED WHEN SPECIFIED.
4. ACTUAL NUMBER OF INTERNAL PARALLEL CIRCUITS MAY VARY.
5. LEAD COLORS ARE OPTIONAL. LEADS MUST BE NUMBERED AS SHOWN.

CD0006

REV. DESC: ADD CLASS CONN00000007		
REV. LTR: E	VERSION: 01	TDR: 000001099922
FILE: \AAA\00005\141	REVISED: 10:24:49 02/19/2019	BY: ENBRIRO
MTL: -	© □	

BALDOR - RELIANCE®

3PH, SV, 3 LEADS, WYE OR DELTA CONNECTED

SH 1 of 1