

ABB BALDOR RELIANCE III

Customer information packet

CFSWDL3506

.75HP, 3450RPM, 1PH, 60HZ, 56C, 3516L, TEFC, F1

Class - None

Division - Not Applicable

Specifications

Enclosure	TEFC
Frame	56C
Frame Material	Stainless Steel
Frequency	60.00 Hz
Haz Area Class and Group	None
Haz Area Division	Not Applicable
Motor Letter Type	Cap Start, Induction Run
Output @ Frequency	.750 HP @ 60 HZ
Phase	1
Synchronous Speed @ Frequency	3600 RPM @ 60 HZ
Voltage @ Frequency	115.0 V @ 60 HZ 230.0 V @ 60 HZ
Agency Approvals	CSA UR
Ambient Temperature	40 °C
Auxiliary Box	NO AUXILLARY BOX
Auxiliary Box Lead Termination	None
Base Indicator	Rigid
Bearing Grease Type	Polyrex EM (-20F +300F)
Blower	None
Current @ Voltage	9.200 A @ 115.0 V 4.800 A @ 208.0 V 4.600 A @ 230.0 V
Design Code	N
Drip Cover	No Drip Cover
Duty Rating	CONT
Efficiency @ 100% Load	64.0 %
Electrically Isolated Bearing	Not Electrically Isolated
Feedback Device	NO FEEDBACK
Front Shaft Indicator	None
Heater Indicator	No Heater
High Voltage Full Load Amps	4.6 a

Part Detail

Revision	E
Type	AC
Mech. spec.	35E4732
Base	
Status	PRD/A
Elec. spec.	35WGL342
Layout	35LYE4732
Eff. date	08-30-2023
CD Diagram	CD0648
Poles	02
Leads	7#18,0#,0#,0# Y
Proprietary	False
Created date	07-21-2017

Insulation Class	F
Inverter Code	Not Inverter
KVA Code	K
Lifting Lugs	No Lifting Lugs
Locked Bearing Indicator	Locked Bearing
Motor Finish	UNPAINTED
Motor Lead Quantity/Wire Size	@ AWG 7 @ 18 AWG
Motor Lead Termination	Flying Leads
Motor Standards	NEMA
Motor Type	3516L
Mounting Arrangement	F1
Number of Poles	2
Overall Length	13.96 IN
Power Factor	81
Product Family	WD All SD Non-Encapsulated
Pulley End Bearing Type	Sealed Bearing
Pulley Face Code	C-Face
Pulley Shaft Indicator	Standard
Rodent Screen	None
RoHS Status	ROHS COMPLIANT
Service Factor	1.25
Shaft Diameter	0.625 IN
Shaft Ground Indicator	No Shaft Grounding
Shaft Rotation	Reversible
Shaft Slinger Indicator	No Slinger
Speed	3450 rpm
Speed Code	Single Speed
Starting Method	Direct on line
Thermal Device - Bearing	None
Thermal Device - Winding	None
Vibration Sensor Indicator	No Vibration Sensor
Winding Thermal 1	None
Winding Thermal 2	None

Nameplate

NP4427ALG30

CAT #	CFSWDL3506	WT	33	LBS	
SPEC	35E4732L342G1	ENCL	TEFC		
SER #		CC		IP	69
HP	.75	NEMA NOM. EFF		64	
VOLTS	115/230				
AMPS	9.2/4.6	PF	81		
RATING	40C AMB-CONT				
RPM	3450				
FRAME	56C	HZ	60	CODE	K
		CLASS	F		
SER.F.	1.25	SF AMP	11.2/5.6	PH	1
		DES	N		
DE	6205	ODE	6205		
LUBRICATION	POLYREX EM				
				QR	
YR					

ABB Motors and Mechanical Inc.

WINDING # 35WGL342

Typical performance - not guaranteed values.

0.75 HP 1 PH 60 HZ 3450 RPM 230 V 3516L

TORQUES (LB-FT): PO=2.42 PU=2.02 LR=4.59 LRA=29.3

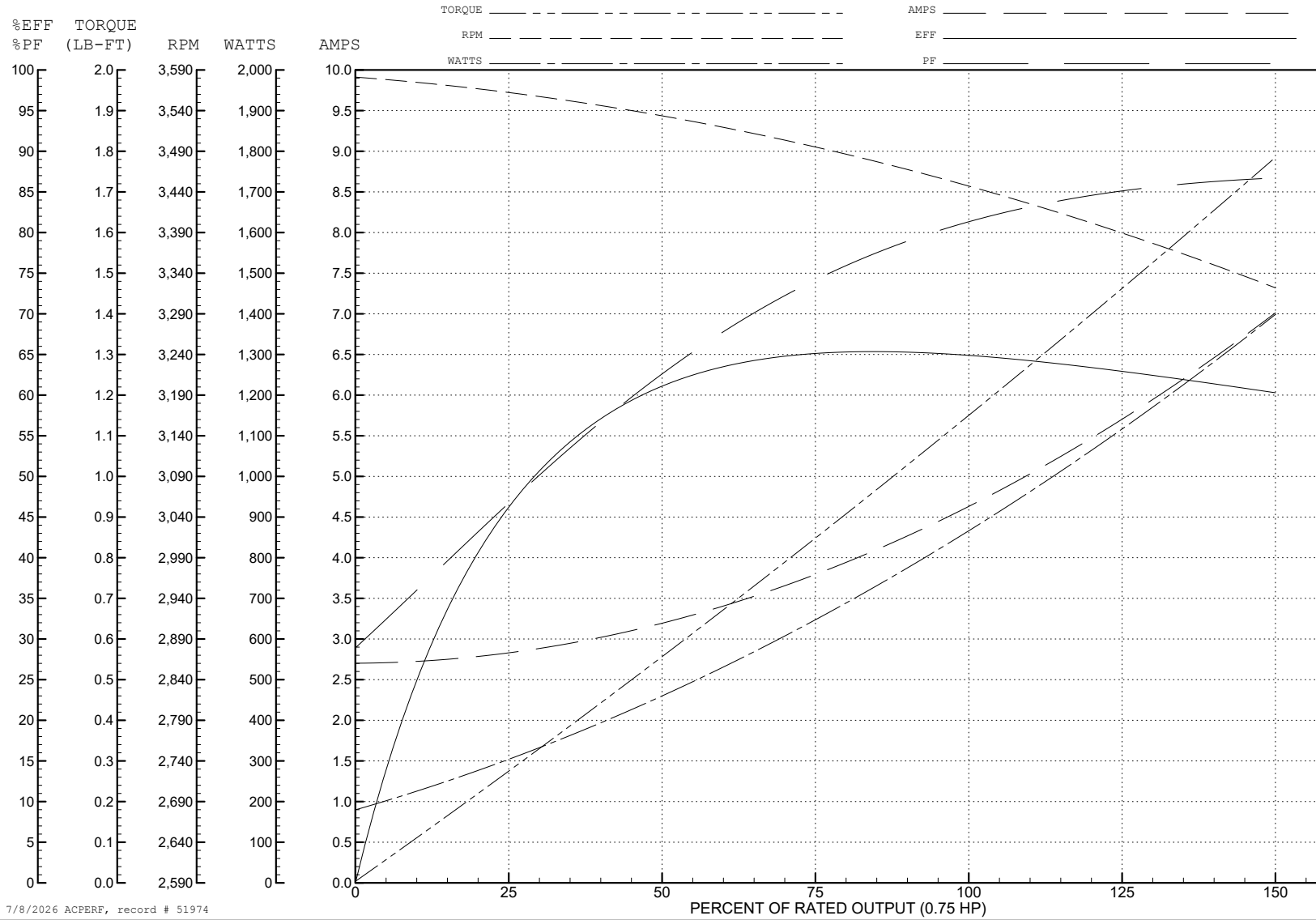

7/8/2026 ACPERF, record # 51974

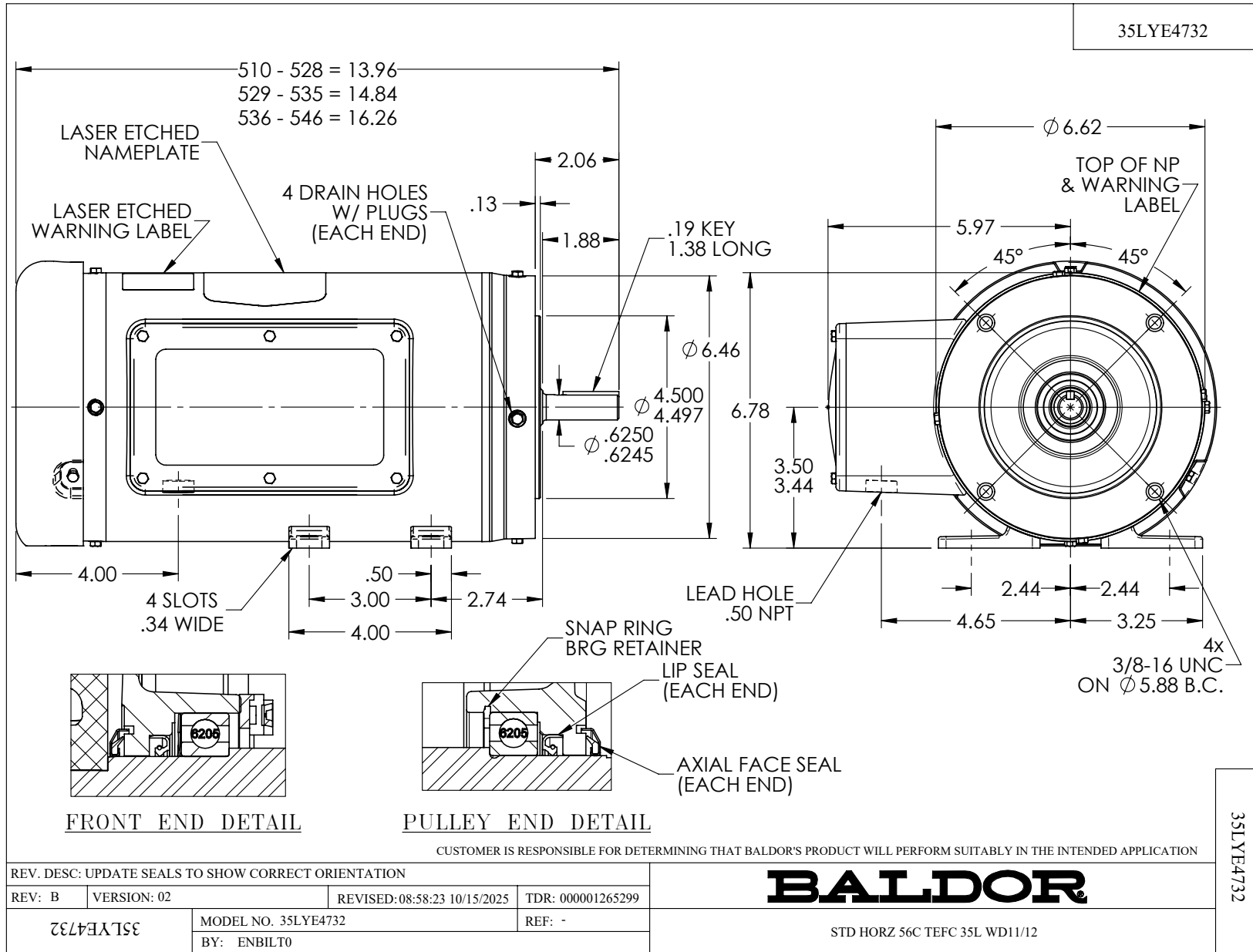

CD0648

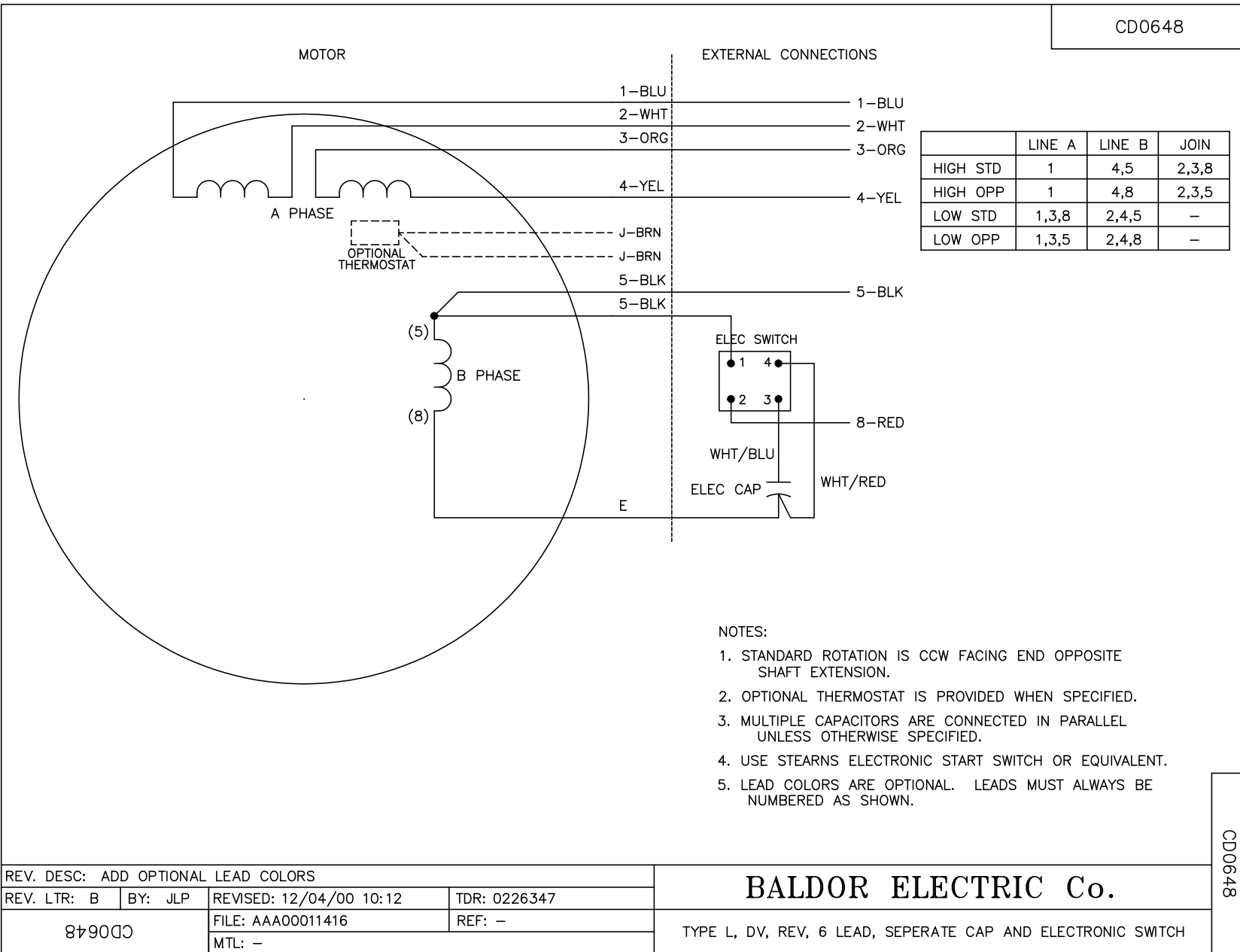

REV. DESC: ADD OPTIONAL LEAD COLORS			
REV. LTR: B	BY: JLP	REVISED: 12/04/00 10:12	TDR: 0226347
879000		FILE: AAA00011416	REF: -
		MTL: -	

BALDOR ELECTRIC Co.

TYPE L, DV, REV, 6 LEAD, SEPERATE CAP AND ELECTRONIC SWITCH

CD0648