

BALDOR • RELIANCE

Customer information packet

CEWDM4468T

60HP, 890RPM, 3PH, 60HZ, 405TC, TEFC, F1

Class - None

Division - Not Applicable

Copyright © All product information within this document is subject to ABB Motors and Mechanical Inc. copyright © protection, unless otherwise noted.

9/9/2024 7:19:11 AM

Specifications

Enclosure	TEFC
Frame	405TC
Frame Material	Iron
Frequency	60.00 Hz
Haz Area Class and Group	None
Haz Area Division	Not Applicable
Motor Letter Type	Three Phase
Output @ Frequency	60.000 HP @ 60 HZ
Phase	3
Synchronous Speed @ Frequency	900 RPM @ 60 HZ
Voltage @ Frequency	230.0 V @ 60 HZ 460.0 V @ 60 HZ
Agency Approvals	CSA EEV CCSA US
Ambient Temperature	40 °C
Auxillary Box	No Auxillary Box
Base Indicator	Rigid
Bearing Grease Type	Polyrex EM (-20F +300F)
Current @ Voltage	157.000 A @ 230.0 V 78.400 A @ 460.0 V
Design Code	B
Drip Cover	No Drip Cover
Duty Rating	CONT
Efficiency @ 100% Load	92.4 %
Enclosure Modification	Severe Duty Features
Feedback Device	NO FEEDBACK
Heater Indicator	No Heater
High Voltage Full Load Amps	78.4 a
Insulation Class	F
Inverter Code	Inverter Ready
IP Rating	IP55
KVA Code	F

Part detail

Revision	A
Type	AC
Mech. spec.	
Base	
Status	PRD/A
Elec. spec.	A40WG0790
Layout	617429-503
Eff. date	11-01-2021
CD Diagram	416820-002
Poles	08
Leads	3#4,6#6
Proprietary	False
Created date	08-29-2019

Motor Lead Quantity/Wire Size	3 @ 4 AWG
Motor Standards	NEMA
Motor Type	A40060M
Mounting Arrangement	F1
Number of Poles	8
Overall Length	38.20 IN
Power Factor	77
Product Family	Washdown Features
Pulley End Bearing Type	Ball
Pulley Face Code	C-Face
Service Factor	1.15
Shaft Diameter	2.875 IN
Shaft Ground Indicator	No Shaft Grounding
Shaft Rotation	Reversible
Shaft Slinger Indicator	Shaft Slinger
Speed	890 rpm
Speed Code	Single Speed
Starting Method	Direct on line
Thermal Device - Bearing	None
Thermal Device - Winding	None

Nameplate

NP2496L	
MOBIL POLYREX EM	

NP2428L

SPEC NO.	A40-6569-0790	CAT.NO.	CEWDM4468T	FRAME	405TC
HP	60	VOLTS	230/460	PHASE	3
				DESIGN	B
				TYPE	P
RPM	890	AMPS	157/78.4	HZ	60
				AMB	40
				SF	1.15
DRIVE END BEARING	80BC03JPP30A	DUTY	CONT	INSUL.CLASS	F
OPP D.E. BEARING	80BC03JPP30A	ENCL	TEFC	CODE	F
SER.NO.		POWER FACTOR	77	NEMA-NOM-EFFICIENCY	92.4
				MAX CORR KVAR	18
				GUARANTEED EFFICIENCY	91
	IP55			NEMA NOM/CSA QUOTED EFF	
	4:1CT AND 4:1VT ON VPWM INVERT			ER, 1.00SF	
				MOTOR WEIGHT	

617429-503

DUTY MASTER ALTERNATING CURRENT MOTORS

SQUIRREL-CAGE INDUCTION

ENCLOSURE: TOTALLY ENCLOSED

FRAME G405TC ABOVE NEMA RATINGS

COOLING: FAN COOLED

MOUNTING: FOOT

INCLUDES 404TC FRAME MOUNTING HOLES

XT/ECP SEVERE DUTY ENCLOSURE

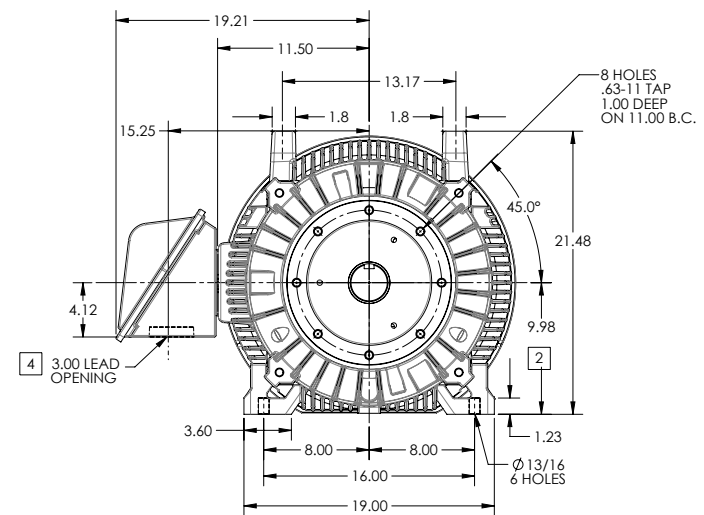
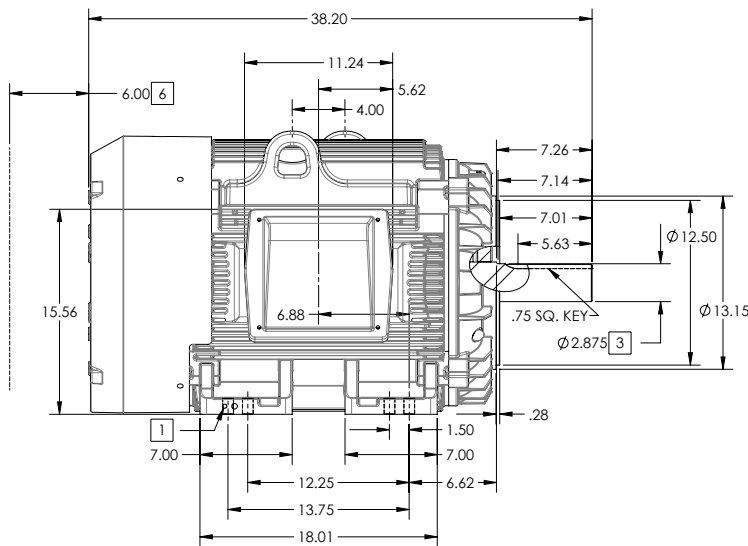

1. GROUND HOLES QTY 1 1/2-13 TAP; QTY 1 3/8-16 TAP
2. VARIES +.00-.06
3. VARIES +.000-.001
4. ON STANDARD MOTORS THIS IS CONDUIT SIZE. ON XT AND CORROSION PROOF MOTOR THIS IS PIPE TAP.
5. MOTOR WEIGHTS MAY VARY BY 15% DEPENDING ON RATING.
6. OBSTRUCTION MUST NOT ENCROACH ON AIR INLET
7. MAX FACE RUNOUT AND FIT ECCENTRICITY = 0.007 T.I.R.

[5] WEIGHT (LBS): 1370

CONDUIT BOX LOCATED ON OPPOSITE SIDE WHEN F-2.
IF MOUNTING CLEARANCE DETAILS ARE REQUIRED, CONSULT FACTORY.
MAXIMUM PERMISSIBLE SHAFT RUNOUT WHEN MEASURED AT END OF STANDARD SHAFT EXTENSION IS .003" T.I.R. TO 5 INCH DIA.

DIMENSIONS ARE IN INCHES; SEE SHEET 2 FOR DIMENSIONS IN MILLIMETERS

CUSTOMER IS RESPONSIBLE FOR DETERMINING THAT MOTOR PERFORMANCE IS SUITABLE IN THE APPLICATION.

SHEET NUMBER
1 OF 2

605-627219

REV. DESC: CHANGE BA FROM 6.76 TO 6.62	TDR: 00000848770
REV: B VERSION: 02	REVISED: 01-18-01 04/14/2014
MODEL NO. 617429-503	REF:
BY: MGHMMZ2	Material:

BALDOR

G405TC/404TC STD - FOOTED - XT/ECP SEVERE DUTY ENCLOSURE

617429-503

DUTY MASTER ALTERNATING CURRENT MOTORS

SQUIRREL-CAGE INDUCTION

ENCLOSURE: TOTALLY ENCLOSED

FRAME G405TC ABOVE NEMA RATINGS

COOLING: FAN COOLED

MOUNTING: FOOT

INCLUDES 404TC FRAME MOUNTING HOLES

XT/ECP SEVERE DUTY ENCLOSURE

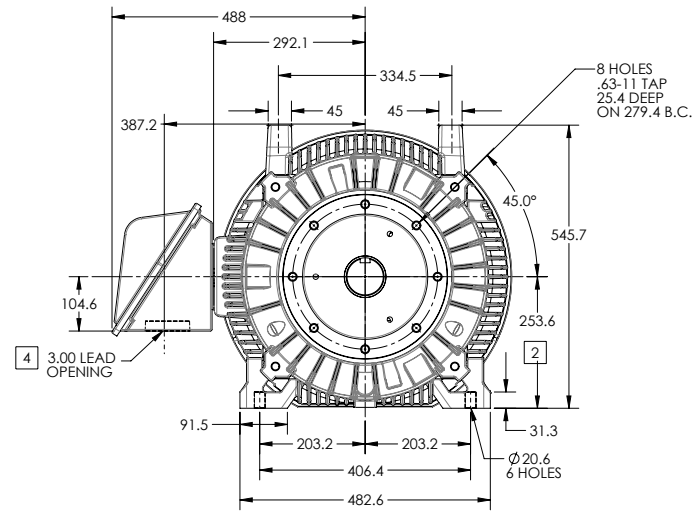
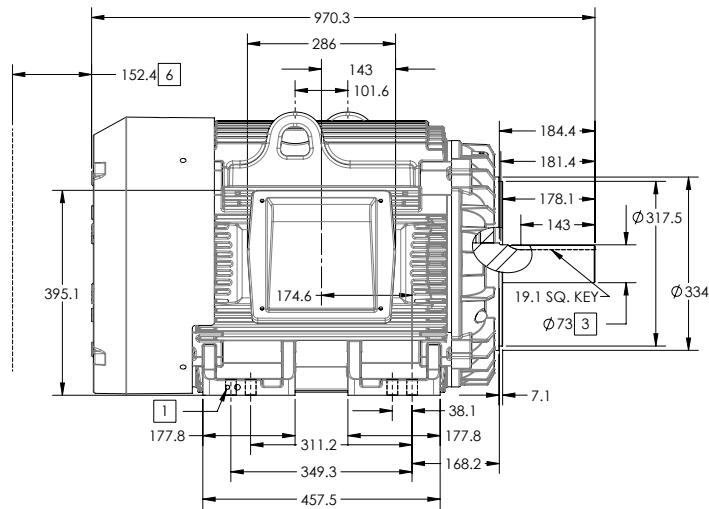

1. GROUND HOLES QTY 1 1/2-13 TAP; QTY 1 3/8-16 TAP
2. VARIES +0, -1.5
3. VARIES +.00, -.03
4. ON STANDARD MOTORS THIS IS CONDUIT SIZE. ON XT AND CORROSION PROOF MOTOR THIS IS PIPE TAP.
5. MOTOR WEIGHTS MAY VARY BY 15% DEPENDING ON RATING.
6. OBSTRUCTION MUST NOT ENCROACH ON AIR INLET
7. MAX FACE RUNOUT AND FIT ECCENTRICITY = 0.178 T.I.R.

[5] WEIGHT (KGS): 630

CONDUIT BOX LOCATED ON OPPOSITE SIDE WHEN F-2.
IF MOUNTING CLEARANCE DETAILS ARE REQUIRED, CONSULT FACTORY.
MAXIMUM PERMISSIBLE SHAFT RUNOUT WHEN MEASURED AT END OF STANDARD SHAFT EXTENSION IS .08 MM T.I.R. TO 127 MM DIA.

DIMENSIONS ARE IN MILLIMETERS; SEE SHEET 1 FOR DIMENSIONS IN INCHES

CUSTOMER IS RESPONSIBLE FOR DETERMINING THAT MOTOR PERFORMANCE IS SUITABLE IN THE APPLICATION.

SHEET NUMBER
2 OF 2

605-627219

REV. DESC: CHANGE BA FROM 6.76 TO 6.62	TDR: 00000848770
REV: B VERSION: 02	REVISED: 01-18-01 04/14/2014
MODEL NO. 617429-503	REF:
BY: MGHMZZ	Material:

BALDOR

G405TC/404TC STD - FOOTED - XT/ECP SEVERE DUTY ENCLOSURE

416820-002

A-C MOTOR
 CONNECTION DIAGRAM
 STANDARD 9 LEAD DELTA-CONNECTED

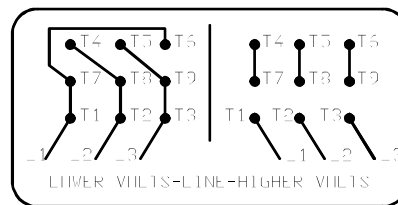
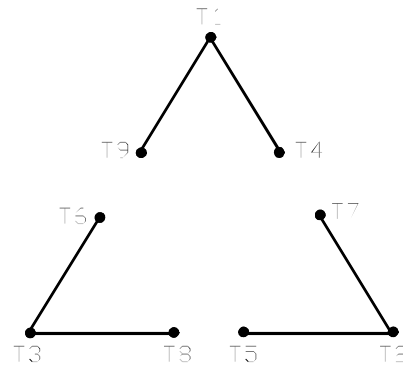

(N.P. 1575-B)

416820-002

REV. DESC: FONT CHANGE FOR PDF SEARCHABLE		
REV. LTR: A	VERSION: 01	TDR: 000001009382
FILE: \MGA\00000\661	REVISED: 02:46:19 02/13/2020	BY: MGHMTT
MTL: -	© □	

BALDOR - RELIANCE®

CONN DIAG - STANDARD 9 LEAD, DELTA-CONNECTED

SH 1 of 1