

# **ABB BALDOR RELIANCE III**

---

## **Customer information packet** CESSWDM3558T-5

2HP, 1765RPM, 3PH, 60HZ, 145TC, 3528M, TEFC, F1

Class - None

Division - Not Applicable

**Specifications**

<b>Enclosure</b>	TEFC
<b>Frame</b>	145TC
<b>Frame Material</b>	Stainless Steel
<b>Frequency</b>	60.00 Hz
<b>Haz Area Class and Group</b>	None
<b>Haz Area Division</b>	Not Applicable
<b>Motor Letter Type</b>	Three Phase
<b>Output @ Frequency</b>	2.000 HP @ 60 HZ
<b>Phase</b>	3
<b>Synchronous Speed @ Frequency</b>	1800 RPM @ 60 HZ
<b>Voltage @ Frequency</b>	575.0 V @ 60 HZ
<b>Agency Approvals</b>	CSA EEV NEMA PREMIUM UR
<b>Ambient Temperature</b>	40 °C
<b>Auxiliary Box</b>	NO AUXILLARY BOX
<b>Auxiliary Box Lead Termination</b>	None
<b>Base Indicator</b>	Rigid
<b>Bearing Grease Type</b>	Polyrex EM (-20F +300F)
<b>Blower</b>	None
<b>Current @ Voltage</b>	2.150 A @ 575.0 V
<b>Design Code</b>	B
<b>Drip Cover</b>	No Drip Cover
<b>Duty Rating</b>	CONT
<b>Efficiency @ 100% Load</b>	86.5 %
<b>Electrically Isolated Bearing</b>	Not Electrically Isolated
<b>Feedback Device</b>	NO FEEDBACK
<b>Front Shaft Indicator</b>	None
<b>Heater Indicator</b>	No Heater
<b>High Voltage Full Load Amps</b>	2.2 a
<b>Insulation Class</b>	H
<b>Inverter Code</b>	Not Inverter

**Part Detail**

<b>Revision</b>	B
<b>Type</b>	AC
<b>Mech. spec.</b>	35VV818
<b>Base</b>	
<b>Status</b>	PRD/A
<b>Elec. spec.</b>	35WGZ823
<b>Layout</b>	35LYVV818
<b>Eff. date</b>	08-19-2025
<b>CD Diagram</b>	CD0006
<b>Poles</b>	04
<b>Leads</b>	3#18
<b>Proprietary</b>	False
<b>Created date</b>	03-11-2022

<b>KVA Code</b>	L
<b>Lifting Lugs</b>	No Lifting Lugs
<b>Locked Bearing Indicator</b>	Locked Bearing
<b>Motor Lead Quantity/Wire Size</b>	3 @ 18 AWG
<b>Motor Lead Termination</b>	Flying Leads
<b>Motor Standards</b>	NEMA
<b>Motor Type</b>	3528M
<b>Mounting Arrangement</b>	F1
<b>Number of Poles</b>	4
<b>Overall Length</b>	13.42 IN
<b>Power Factor</b>	81
<b>Product Family</b>	Wash Down All Stainless Steel
<b>Pulley End Bearing Type</b>	Sealed Bearing
<b>Pulley Face Code</b>	C-Face
<b>Pulley Shaft Indicator</b>	Standard
<b>Rodent Screen</b>	None
<b>Service Factor</b>	1.15
<b>Shaft Diameter</b>	0.875 IN
<b>Shaft Ground Indicator</b>	No Shaft Grounding
<b>Shaft Rotation</b>	Reversible
<b>Shaft Slinger Indicator</b>	No Slinger
<b>Speed</b>	1765 rpm
<b>Speed Code</b>	Single Speed
<b>Starting Method</b>	Direct on line
<b>Thermal Device - Bearing</b>	None
<b>Thermal Device - Winding</b>	None
<b>Vibration Sensor Indicator</b>	No Vibration Sensor
<b>Winding Thermal 1</b>	None
<b>Winding Thermal 2</b>	None

**Nameplate**

<b>NP1953A05</b>									
<b>CAT.NO.</b>	CESSWDM3558T-5								
<b>SPEC.</b>	35VV818Z823G1								
<b>HP</b>	2								
<b>VOLTS</b>	575								
<b>AMP</b>	2.15								
<b>RPM</b>	1765								
<b>FRAME</b>	145TC		<b>HZ</b>	60		<b>PH</b>	3		
<b>SER.F.</b>	1.15	<b>CODE</b>	L	<b>DES</b>	B	<b>CLASS</b>	H		
<b>NEMA-NOM-EFF</b>	86.5	<b>PF</b>	81						
<b>RATING</b>	40C AMB-CONT								
<b>CC</b>	010A	<b>USABLE AT 208V</b>	N/A						
<b>DE</b>	6205	<b>ODE</b>	6203						
<b>ENCL</b>	TEFC	<b>SN</b>							
	4:1CT 4:1VT								

ABB Motors and Mechanical Inc.

WINDING # 35WGZ823

Typical performance - not guaranteed values.

2 HP 3 PH 60 HZ 1765 RPM 575 V 3528M

TORQUES (LB-FT): PO=22.1 PU=13.1 LR=15.85 LRA=18.31

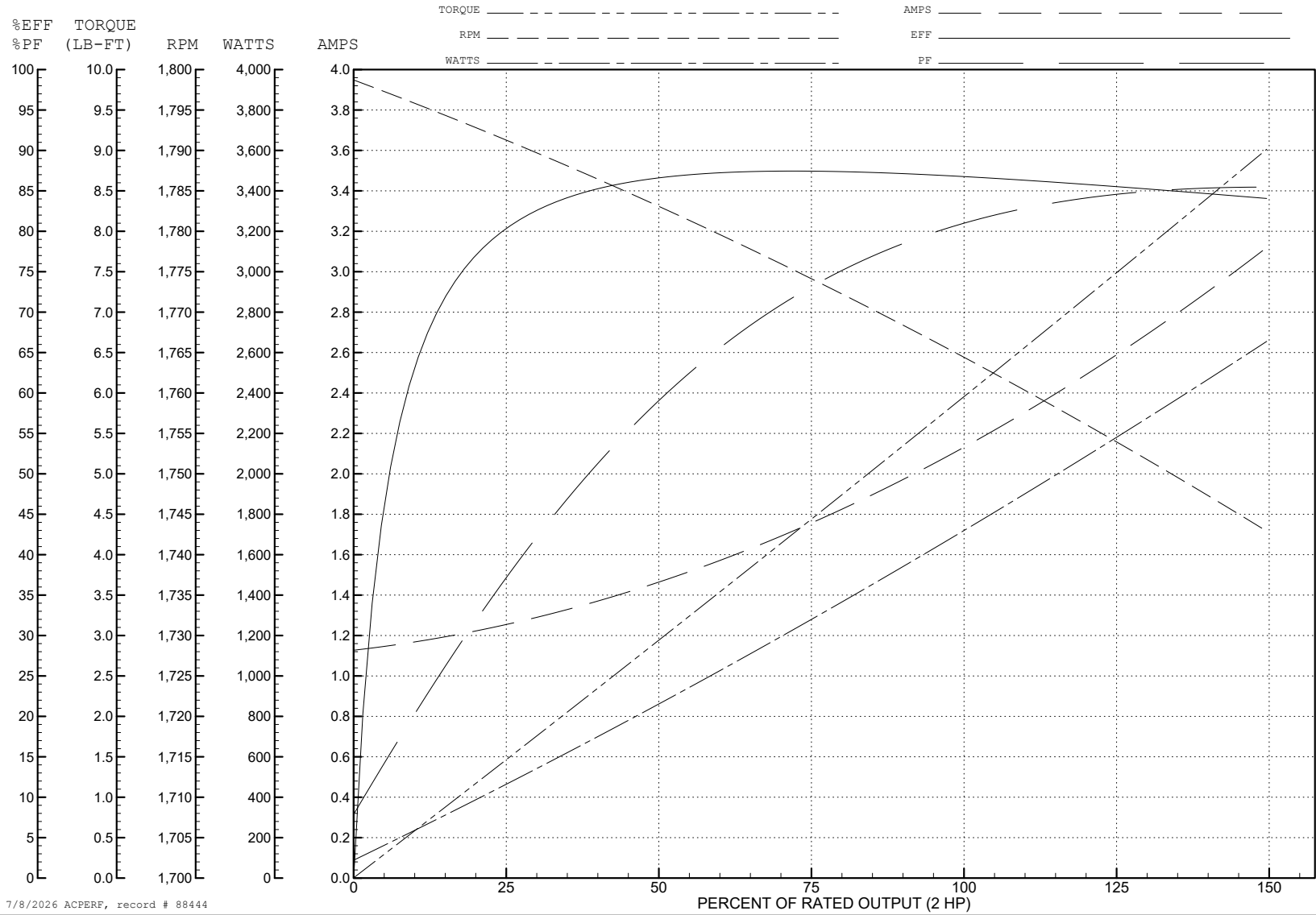

7/8/2026 ACPERF, record # 88444

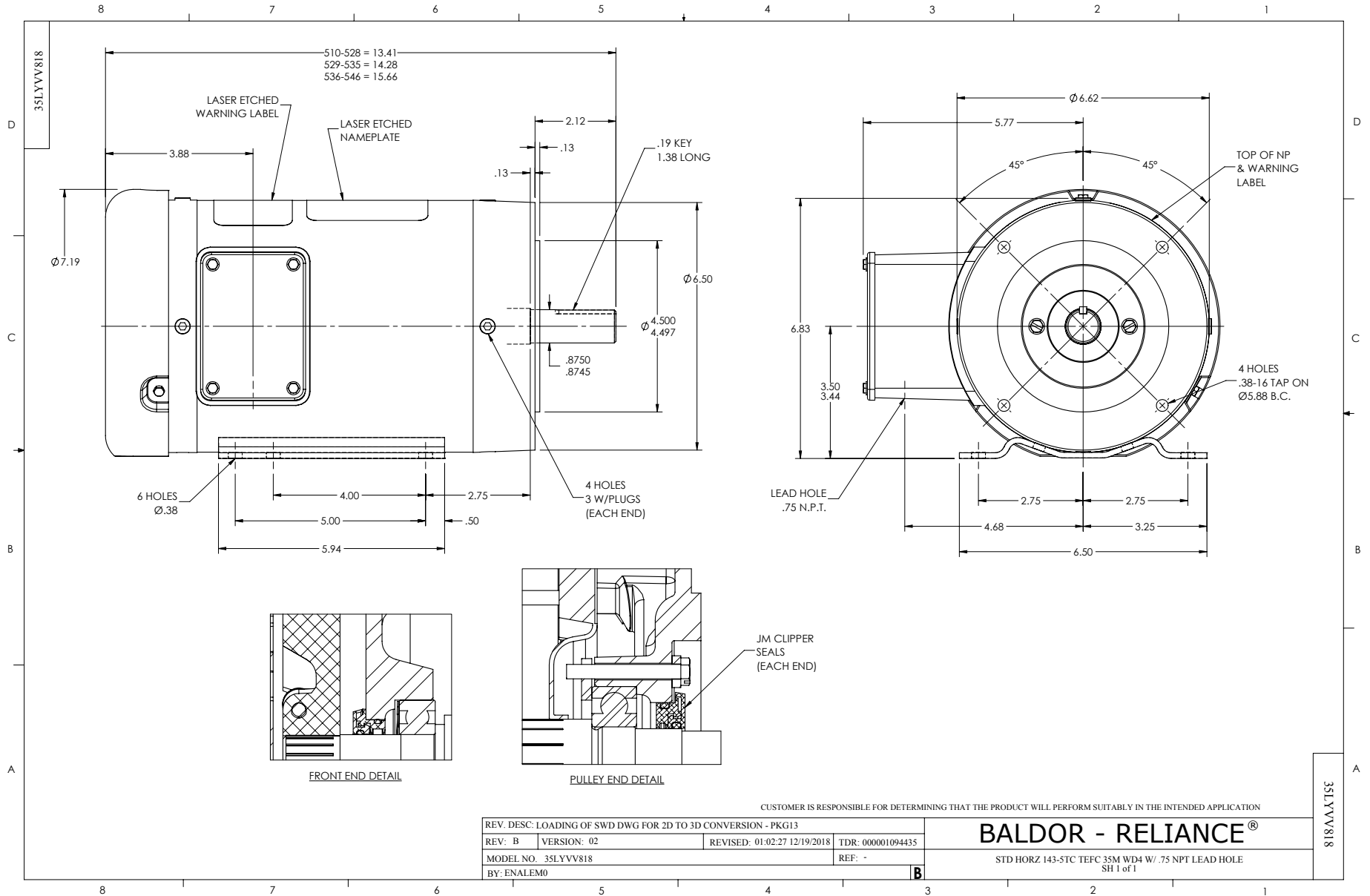

CD0006

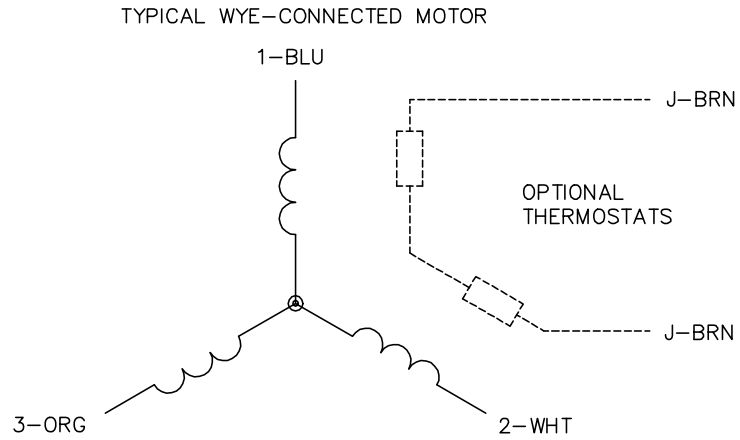

NOTES:

1. THREE LEAD MOTOR MAY BE EITHER WYE CONNECTED OR DELTA CONNECTED.
2. INTERCHANGE ANY TWO LINE LEADS TO REVERSE ROTATION.
3. OPTIONAL THERMOSTATS ARE PROVIDED WHEN SPECIFIED.
4. ACTUAL NUMBER OF INTERNAL PARALLEL CIRCUITS MAY VARY.
5. LEAD COLORS ARE OPTIONAL. LEADS MUST BE NUMBERED AS SHOWN.

CD0006

REV. DESC: ADD CLASS CONN00000007		
REV. LTR: E	VERSION: 01	TDR: 000001099922
FILE: \AAA\00005\141	REVISED: 10:24:49 02/19/2019	BY: ENBRIRO
MTL: -	© □	

**BALDOR - RELIANCE®**

3PH, SV, 3 LEADS, WYE OR DELTA CONNECTED

SH 1 of 1