

ABB BALDOR RELIANCE III

Customer information packet

CEM3546-8

1HP, 1775RPM, 3PH, 60HZ, 56C, 3520M, TEFC, F1, N

Class - None

Division - Not Applicable

Specifications

Enclosure	TEFC
Frame	56C
Frame Material	Steel
Frequency	60.00 Hz
Haz Area Class and Group	None
Haz Area Division	Not Applicable
Motor Letter Type	Three Phase
Output @ Frequency	1.000 HP @ 60 HZ
Phase	3
Synchronous Speed @ Frequency	1800 RPM @ 60 HZ
Voltage @ Frequency	200.0 V @ 60 HZ
Agency Approvals	CURUSEEV NEMA PREMIUM
Ambient Temperature	40 °C
Auxiliary Box	NO AUXILLARY BOX
Auxiliary Box Lead Termination	None
Base Indicator	Rigid
Bearing Grease Type	Polyrex EM (-20F +300F)
Blower	None
Current @ Voltage	3.600 A @ 200.0 V
Design Code	B
Drip Cover	No Drip Cover
Duty Rating	CONT
Efficiency @ 100% Load	85.5 %
Electrically Isolated Bearing	Not Electrically Isolated
Feedback Device	NO FEEDBACK
Front Shaft Indicator	None
Heater Indicator	No Heater
High Voltage Full Load Amps	3.6 a
Insulation Class	F
Inverter Code	Inverter Ready
KVA Code	N

Part Detail

Revision	C
Type	AC
Mech. spec.	35A012
Base	
Status	PRD/A
Elec. spec.	35WGG118
Layout	35LYA012
Eff. date	06-24-2025
CD Diagram	CD0006
Poles	04
Leads	3#18
Proprietary	False
Created date	03-11-2022

Lifting Lugs	No Lifting Lugs
Locked Bearing Indicator	Locked Bearing
Motor Lead Quantity/Wire Size	3 @ 18 AWG
Motor Lead Termination	Flying Leads
Motor Standards	NEMA
Motor Type	3520M
Mounting Arrangement	F1
Number of Poles	4
Overall Length	12.23 IN
Power Factor	67
Product Family	General Purpose
Pulley End Bearing Type	Ball
Pulley Face Code	C-Face
Pulley Shaft Indicator	Standard
Rodent Screen	None
Service Factor	1.15
Shaft Diameter	0.625 IN
Shaft Ground Indicator	No Shaft Grounding
Shaft Rotation	Reversible
Shaft Slinger Indicator	No Slinger
Speed	1775 rpm
Speed Code	Single Speed
Starting Method	Direct on line
Thermal Device - Bearing	None
Thermal Device - Winding	None
Vibration Sensor Indicator	No Vibration Sensor
Winding Thermal 1	None
Winding Thermal 2	None

Nameplate

NP3441L									
CAT.NO.	CEM3546-8								
SPEC.	35A012G118G1								
HP	1								
VOLTS	200								
AMP	3.6								
RPM	1775								
FRAME	56C		HZ	60			PH	3	
SER.F.	1.15	CODE	N	DES	B	CL	F		
NEMA-NOM-EFF	85.5	PF	67						
RATING	40C AMB-CONT								
CC	010A								
DE	6205		ODE	6203					
ENCL	TEFC	SN							
VPWM INVERTER READY									
CT6-60H(10:1)VT3-60H(20:1									
	SFA 3.9								

ABB Motors and Mechanical Inc.

WINDING # 35WGG118

Typical performance - not guaranteed values.

1 HP 3 PH 60 HZ 1774 RPM 200 V 3520M

TORQUES (LB-FT): PO=12.86 PU=7.55 LR=8.76 LRA=31.78

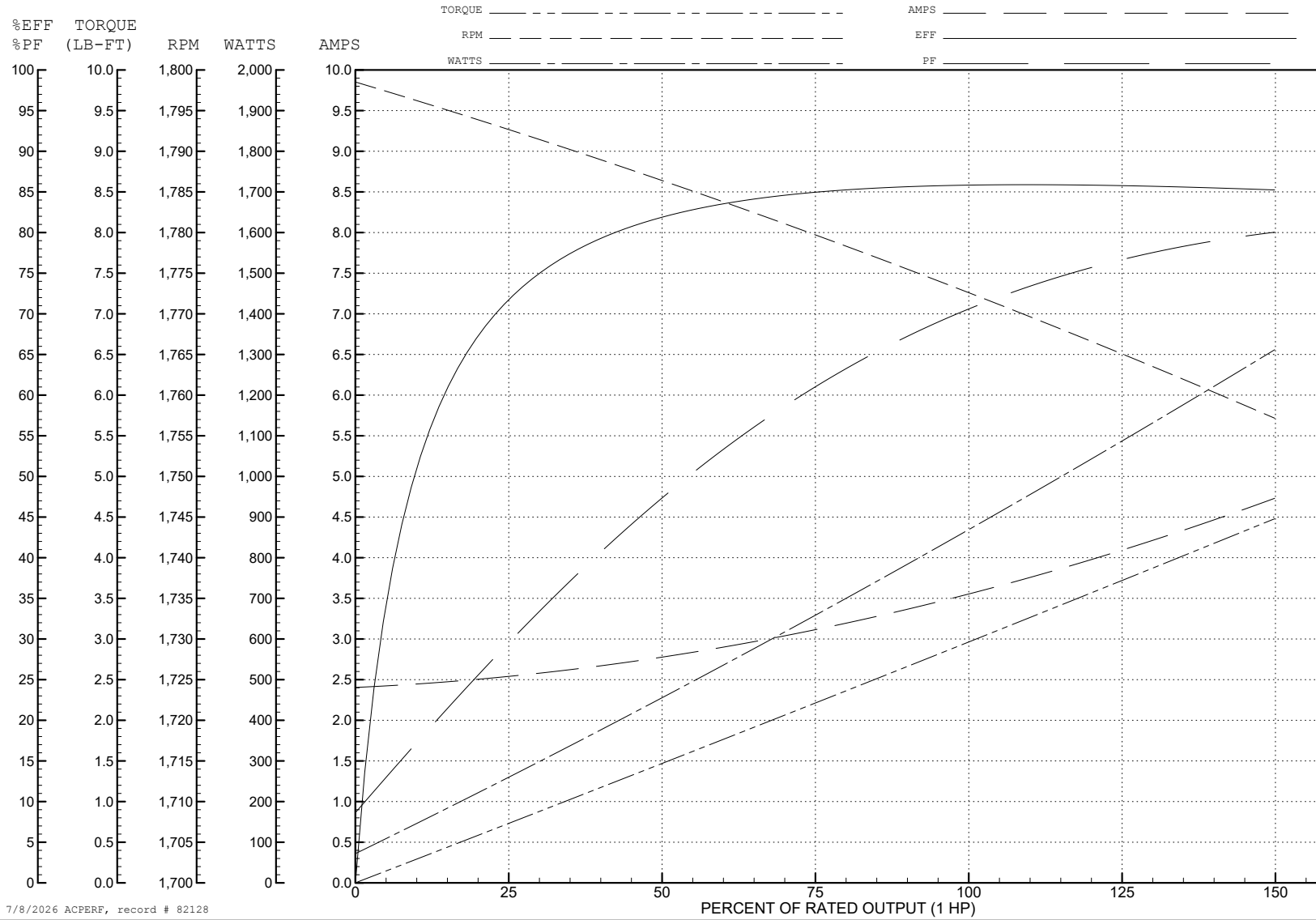

7/8/2026 ACPERF, record # 82128

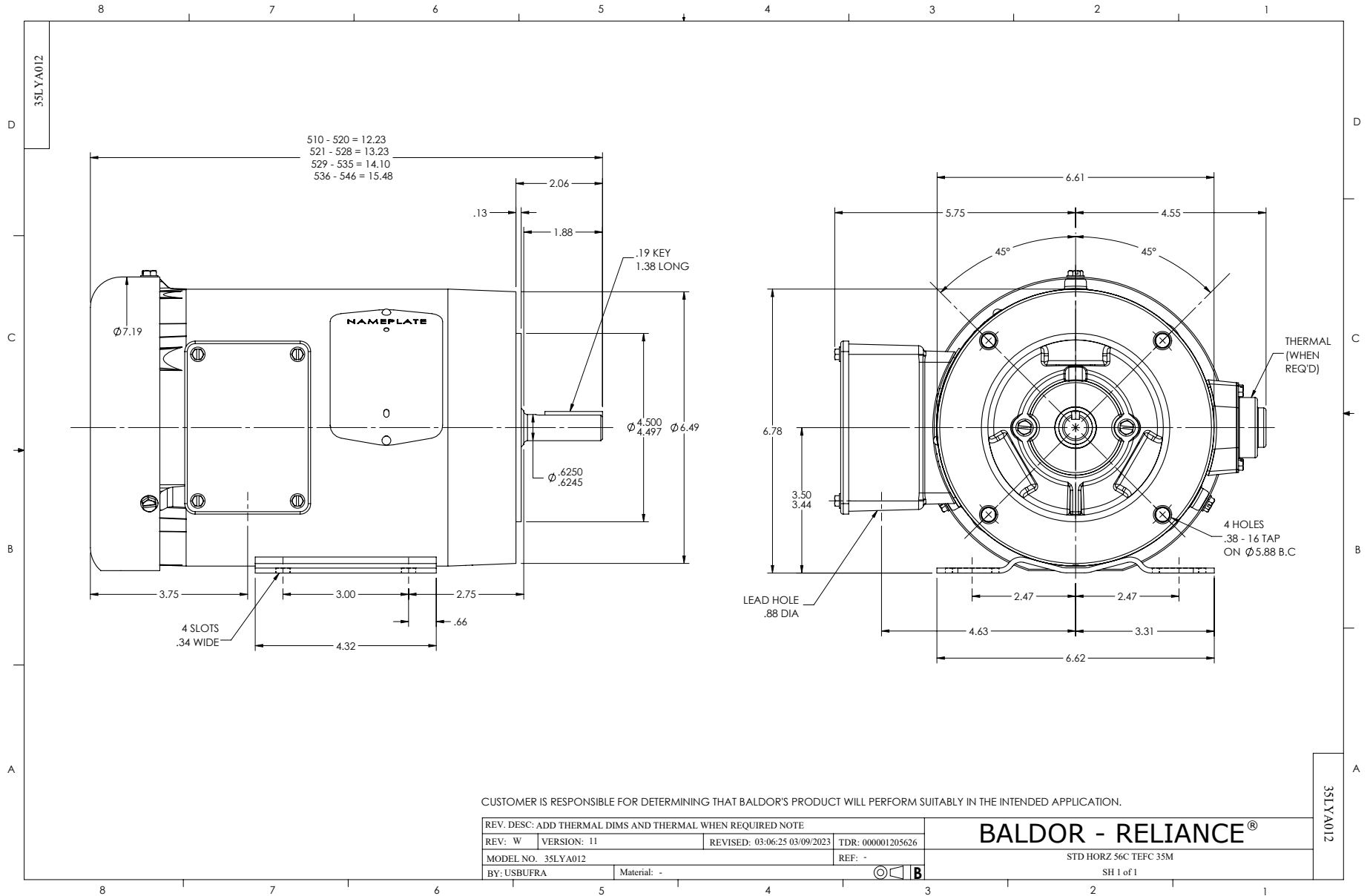

CD0006



NOTES:

1. THREE LEAD MOTOR MAY BE EITHER WYE CONNECTED OR DELTA CONNECTED.
2. INTERCHANGE ANY TWO LINE LEADS TO REVERSE ROTATION.
3. OPTIONAL THERMOSTATS ARE PROVIDED WHEN SPECIFIED.
4. ACTUAL NUMBER OF INTERNAL PARALLEL CIRCUITS MAY VARY.
5. LEAD COLORS ARE OPTIONAL. LEADS MUST BE NUMBERED AS SHOWN.

CD0006

REV. DESC: ADD CLASS CONN00000007		
REV. LTR: E	VERSION: 01	TDR: 000001099922
FILE: \AAA\00005\141	REVISED: 10:24:49 02/19/2019	BY: ENBRIRO
MTL: -		© □

BALDOR - RELIANCE®

3PH, SV, 3 LEADS, WYE OR DELTA CONNECTED

SH 1 of 1