

ABB BALDOR RELIANCE III

Customer information packet

CECP83774T-4

10HP, 1760RPM, 3PH, 60HZ, 215TC, 0748M, TEFC, F

Class - CLI GP A,B,C,D

Division - Division II

Specifications

Enclosure	TEFC
Frame	215TC
Frame Material	Iron
Frequency	60.00 Hz
Haz Area Class and Group	CLI GP A,B,C,D
Haz Area Division	Division II
Motor Letter Type	Three Phase
Output @ Frequency	10.000 HP @ 60 HZ
Phase	3
Synchronous Speed @ Frequency	1800 RPM @ 60 HZ
Voltage @ Frequency	460.0 V @ 60 HZ
Agency Approvals	CSA EEV NEMA PREMIUM NEMA_PREMIUM UR CCSA US
Ambient Temperature	40 °C
Auxiliary Box	NO AUXILLARY BOX
Auxiliary Box Lead Termination	None
Base Indicator	Rigid
Bearing Grease Type	Polyrex EM (-20F +300F)
Blower	None
Constant Torque Speed Range	1.3
Current @ Voltage	12.500 A @ 460.0 V
Design Code	B
Drip Cover	No Drip Cover
Duty Rating	CONT
Efficiency @ 100% Load	91.7 %
Electrically Isolated Bearing	Not Electrically Isolated
Enclosure Modification	841
Feedback Device	NO FEEDBACK
Front Face Code	Standard

Part Detail

Revision	AD
Type	AC
Mech. spec.	07M320
Base	
Status	PRD/A
Elec. spec.	07WGX813
Layout	07LYM320
Eff. date	05-12-2025
CD Diagram	CD0006
Poles	04
Leads	3#14
Proprietary	False
Created date	08-30-2012

Front Shaft Indicator	None
Haz Area Temp Code	T3C
Heater Indicator	No Heater
High Voltage Full Load Amps	12.5 a
Insulation Class	F
Inverter Code	Inverter Duty
KVA Code	H
Lifting Lugs	Standard Lifting Lugs
Locked Bearing Indicator	Locked Bearing
Max Speed	2700 rpm
Motor Lead Exit	Ko Box
Motor Lead Quantity/Wire Size	3 @ 14 AWG
Motor Lead Termination	Ring Terminals
Motor Standards	NEMA
Motor Type	0748M
Mounting Arrangement	F1
Number of Poles	4
Overall Length	20.23 IN
Power Factor	81
Product Family	Chem Process S/P 32-8 IEEE 841
Pulley End Bearing Type	Ball
Pulley Face Code	C-Face
Pulley Shaft Indicator	Standard
Rodent Screen	None
Service Factor	1.15
Shaft Diameter	1.375 IN
Shaft Extension Location	Pulley End
Shaft Ground Indicator	No Shaft Grounding
Shaft Rotation	Reversible
Shaft Slinger Indicator	Shaft Slinger
Speed	1765 rpm
Speed Code	Single Speed
Starting Method	Direct on line
Thermal Device - Bearing	None

Thermal Device - Winding	None
Vibration Sensor Indicator	No Vibration Sensor
Winding Thermal 1	None
Winding Thermal 2	None

Nameplate

NP4328									
CAT.NO.	CECP83774T-4								
SPEC.	07M320X813G1								
HP	10 TE	IP	56						
VOLTS	460								
AMPS	12.3								
R.P.M.	1765								
FRAME	215TC	HZ	60	PH	3				
SER.F.	1.15	CODE	H	DES.	B	CLASS	F		
RATING	40C AMB-CONT								
SN									
DE	6307	ODE	6307						
NEMA NOM. EFF.	91.7	P.F.	81						
GUAR. MIN. EFF.	90.2	CC	010A						
T. CODE	T3C	TEMP=	160						

NP3186

SPEC.	07M320X813G1		
ABMA DE BRG	35BC03X30X		
ABMA ODE BRG	35BC03X30X		
GREASE	POLYREX EM		
MOTOR WEIGHT	231	ROTOR BARS	STATOR BARS 36
MAX. R.P.M.	2700	MAX. KVAR	1.52
INV.TYPE	PWM		
T=	160		
CHP	60	TO	90
CT	1.3	TO	60
VT	-0	TO	60
HTR-VOLTS	N/A	HTR-AMPS	N/A
HTR-WATTS		MAX. SPACE HEATER TEMP.	N/A

ABB Motors and Mechanical Inc.

WINDING # 07WGX813

Typical performance - not guaranteed values.

10 HP 3 PH 60 HZ 1765 RPM 460 V 0748M

TORQUES (LB-FT): PO=80.65 PU=40.2 LR=52.6 LRA=81

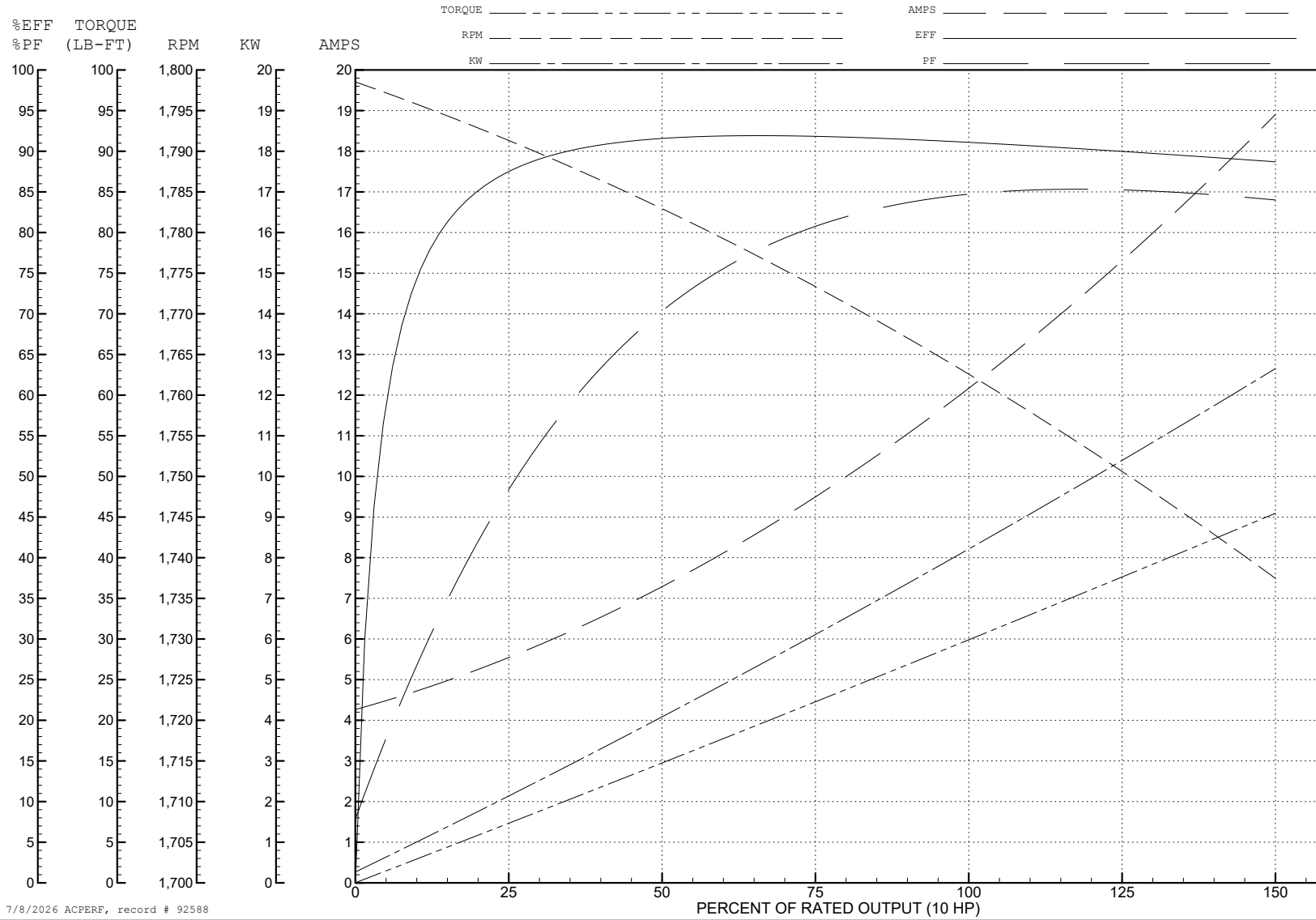

7/8/2026 ACPERF, record # 92588

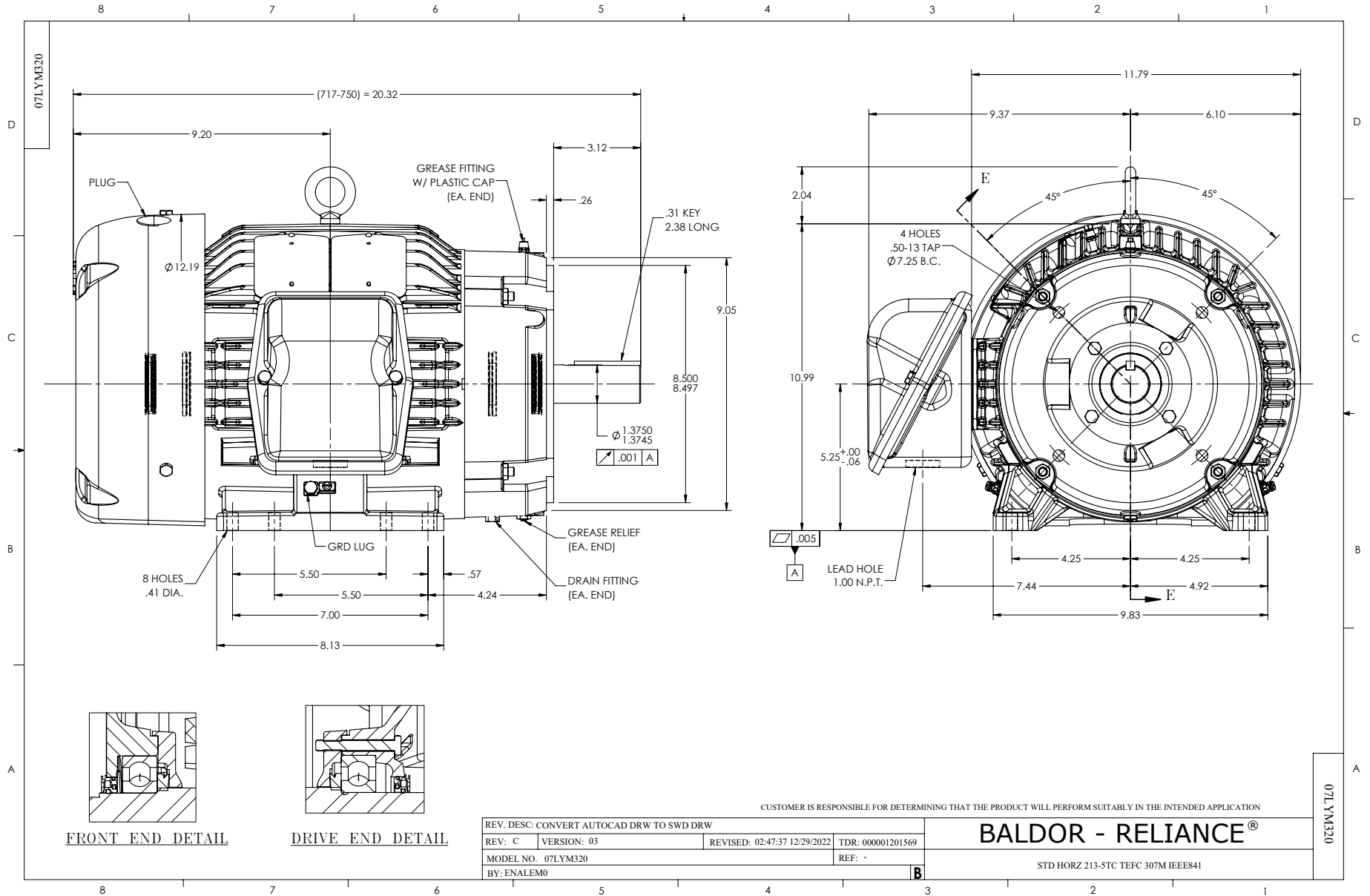

CD0006

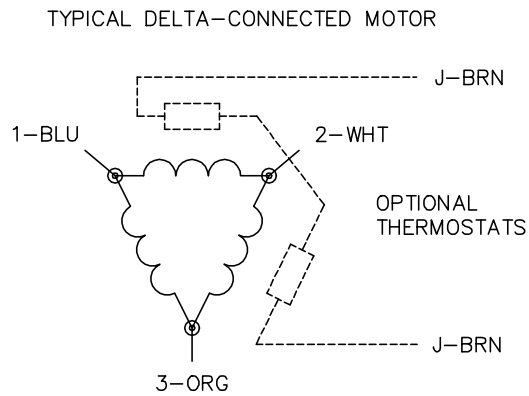
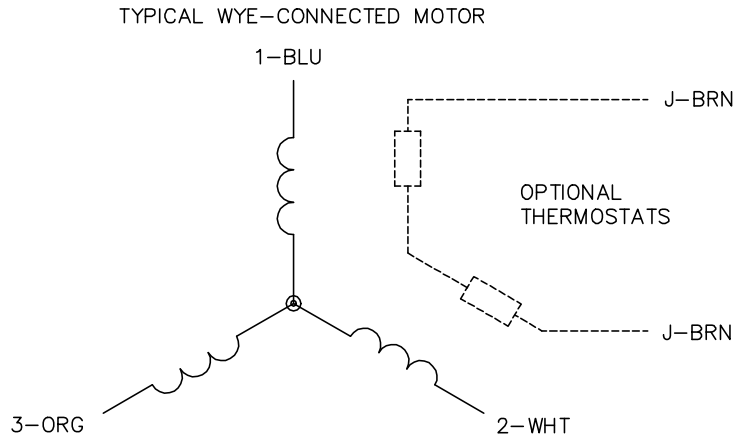

NOTES:

1. THREE LEAD MOTOR MAY BE EITHER WYE CONNECTED OR DELTA CONNECTED.
2. INTERCHANGE ANY TWO LINE LEADS TO REVERSE ROTATION.
3. OPTIONAL THERMOSTATS ARE PROVIDED WHEN SPECIFIED.
4. ACTUAL NUMBER OF INTERNAL PARALLEL CIRCUITS MAY VARY.
5. LEAD COLORS ARE OPTIONAL. LEADS MUST BE NUMBERED AS SHOWN.

CD0006

REV. DESC: ADD CLASS CONN00000007		
REV. LTR: E	VERSION: 01	TDR: 000001099922
FILE: \AAA\00005\141	REVISED: 10:24:49 02/19/2019	BY: ENBRIRO
MTL: -	© □	

BALDOR - RELIANCE®

3PH, SV, 3 LEADS, WYE OR DELTA CONNECTED

SH 1 of 1