

ABB BALDOR RELIANCE III

Customer information packet

CDRXL050544

.5HP, 1740RPM, 1PH, 60HZ, 56C, 3520L, XPFC, F1

Class - CLI GP C,D

Division - Division I

Specifications

Enclosure	XPFC
Frame	56C
Frame Material	Steel
Frequency	60.00 Hz
Haz Area Class and Group	CLI GP C,D
Haz Area Division	Division I
Motor Letter Type	Cap Start, Induction Run
Output @ Frequency	.500 HP @ 60 HZ
Phase	1
Synchronous Speed @ Frequency	1800 RPM @ 60 HZ
Voltage @ Frequency	230.0 V @ 60 HZ 208.0 V @ 60 HZ 115.0 V @ 60 HZ
Agency Approvals	CSA UL
Ambient Temperature	40 °C
Auxiliary Box	NO AUXILLARY BOX
Auxiliary Box Lead Termination	None
Base Indicator	Rigid
Bearing Grease Type	Polyrex EM (-20F +300F)
Blower	None
Current @ Voltage	7.000 A @ 115.0 V 3.500 A @ 230.0 V 3.450 A @ 208.0 V
Design Code	N
Drip Cover	No Drip Cover
Duty Rating	CONT
Efficiency @ 100% Load	66.0 %
Electrically Isolated Bearing	Not Electrically Isolated
Feedback Device	NO FEEDBACK
Front Shaft Indicator	None
Haz Area Temp Code	T3C

Part Detail

Revision	F
Type	AC
Mech. spec.	35X723
Base	
Status	PRD/A
Elec. spec.	35WGG470
Layout	35LYX723
Eff. date	05-29-2026
CD Diagram	CD0001
Poles	04
Leads	6#18
Proprietary	False
Created date	08-01-2022

Heater Indicator	No Heater
High Voltage Full Load Amps	3.5 a
Insulation Class	F
Inverter Code	Not Inverter
KVA Code	L
Lifting Lugs	No Lifting Lugs
Locked Bearing Indicator	Locked Bearing
Motor Lead Quantity/Wire Size	6 @ 18 AWG
Motor Lead Termination	Flying Leads
Motor Standards	NEMA
Motor Type	X3520L
Mounting Arrangement	F1
Number of Poles	4
Overall Length	14.31 IN
Power Factor	70
Product Family	Hazardous Location Motor
Pulley End Bearing Type	Ball
Pulley Face Code	C-Face
Pulley Shaft Indicator	Standard
Rodent Screen	None
Service Factor	1.15
Shaft Diameter	0.625 IN
Shaft Ground Indicator	No Shaft Grounding
Shaft Rotation	Reversible
Shaft Slinger Indicator	No Slinger
Speed	1740 rpm
Speed Code	Single Speed
Starting Method	Direct on line
Thermal Device - Bearing	None
Thermal Device - Winding	Normally Closed Thermostat
Vibration Sensor Indicator	No Vibration Sensor
Winding Thermal 1	None
Winding Thermal 2	None

Nameplate

NP0977XPSL										
NO.									CC	
SER.									TEMP CODE	T3C
SPEC.	35X723G470									
CAT.NO.	CDRXL050544									
HP	.5									
VOLTS	115/208-230									
AMPS	7/3.45-3.5									
RPM	1740				MOTOR WEIGHT		43			
HERTZ	60	PH	1	CL	F	DE BRG	6205			
SER.F.	1.15	DES	N	CODE	L	ODE BRG	6203			
FRAME	56C	GREASE		POLYREX EM						
RATING	40C AMB-CONT									
					NEMA-NOM-EFF		66	PF	70	
	NEMA MG-1 PT 5,IP55									

ABB Motors and Mechanical Inc.

WINDING # 35WGG470

Typical performance - not guaranteed values.

0.5 HP 1 PH 60 HZ 1740 RPM 115 V 3520L

TORQUES (LB-FT): PO=4.22 PU=3.95 LR=6.21 LRA=43.3

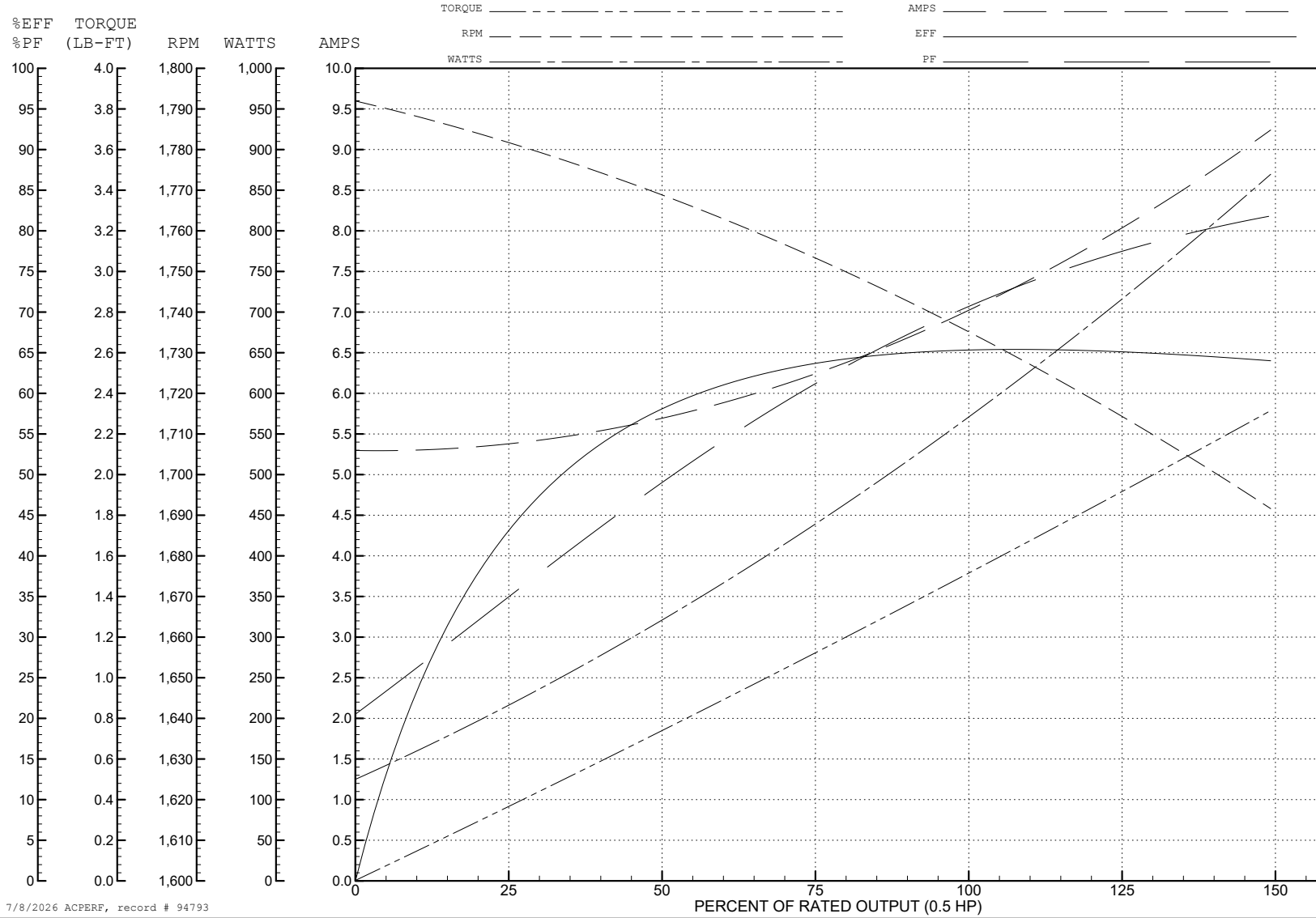

7/8/2026 ACPERF, record # 94793

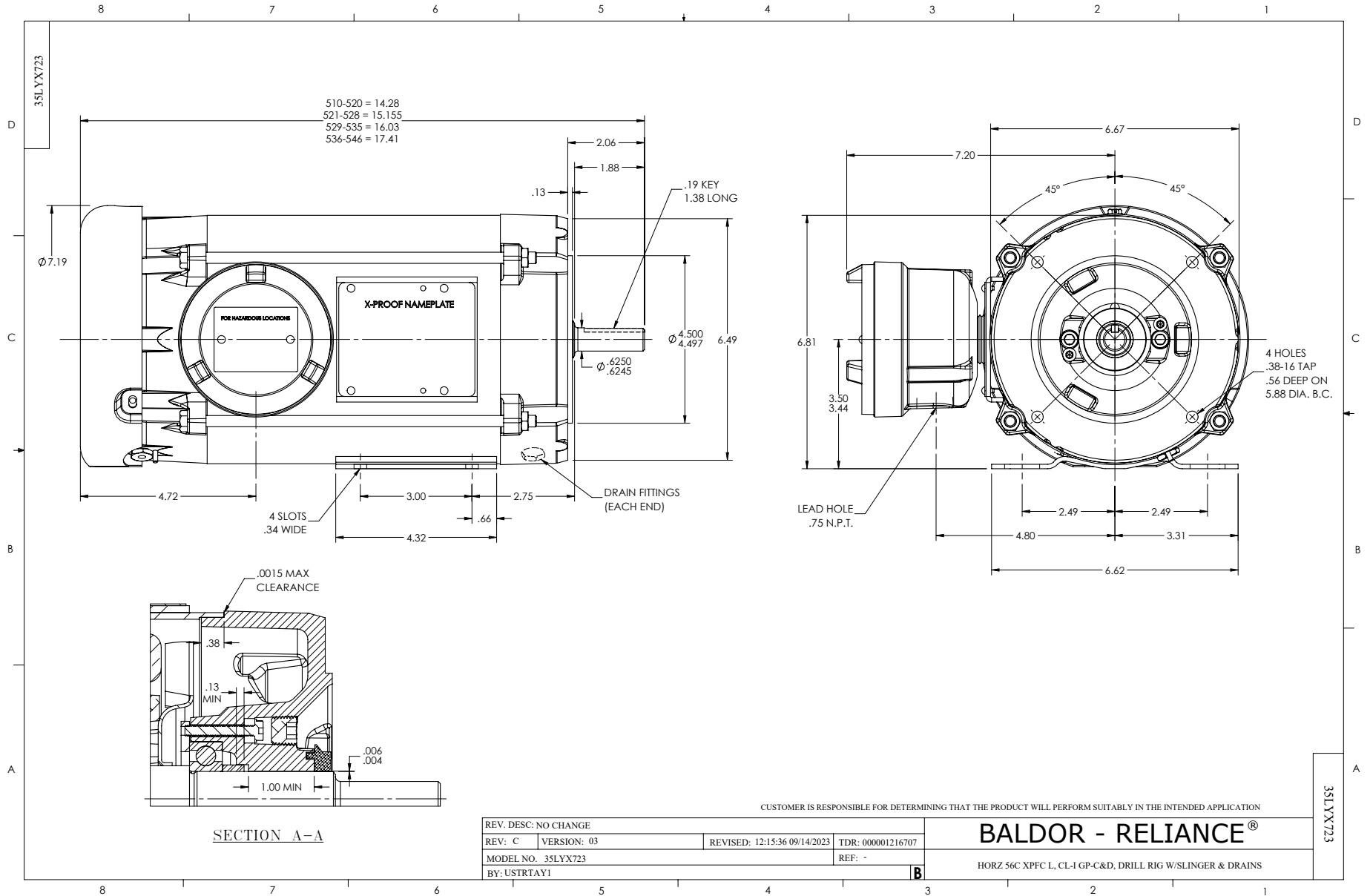

CD0001

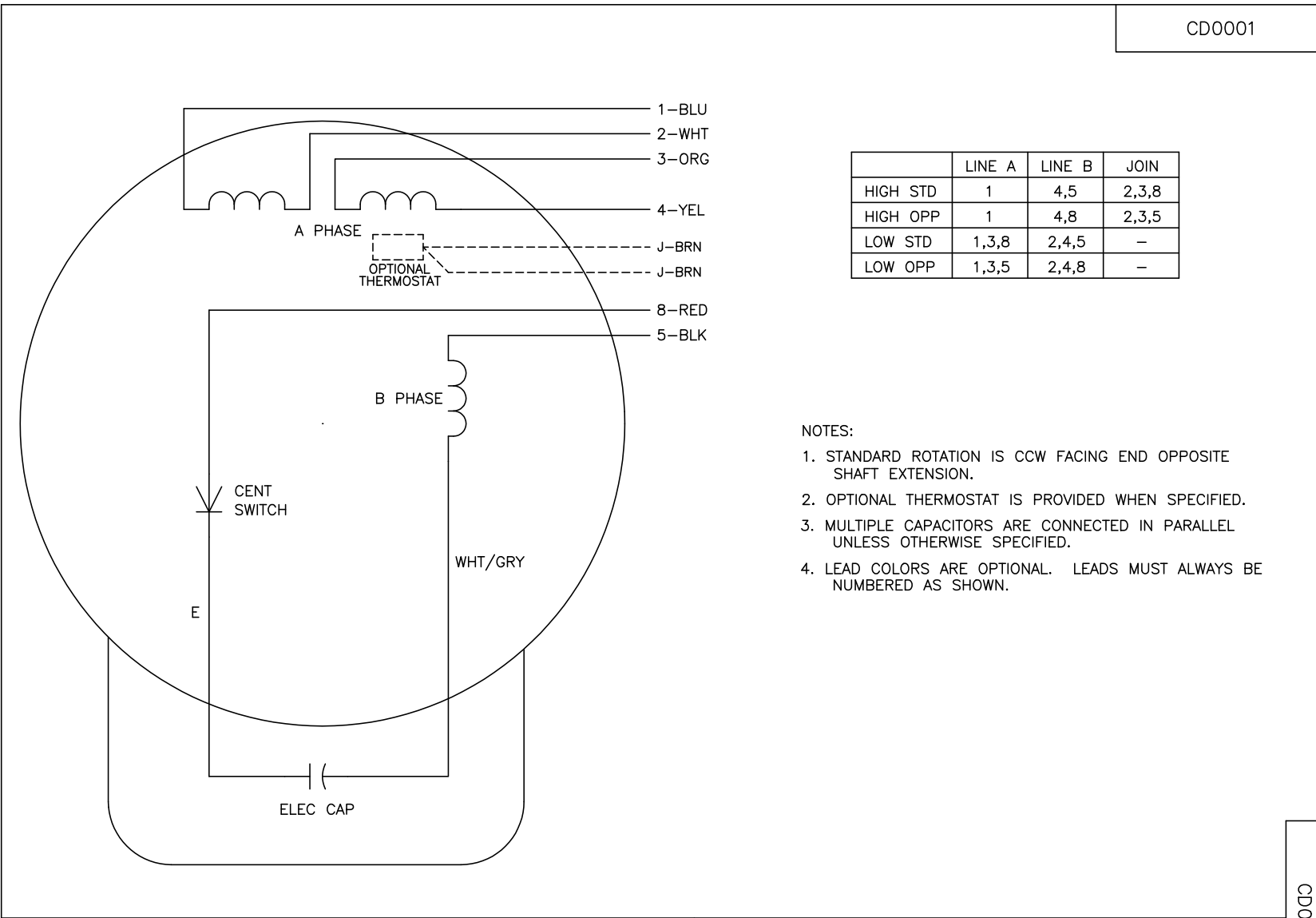

	LINE A	LINE B	JOIN
HIGH STD	1	4,5	2,3,8
HIGH OPP	1	4,8	2,3,5
LOW STD	1,3,8	2,4,5	-
LOW OPP	1,3,5	2,4,8	-

- NOTES:
1. STANDARD ROTATION IS CCW FACING END OPPOSITE SHAFT EXTENSION.
 2. OPTIONAL THERMOSTAT IS PROVIDED WHEN SPECIFIED.
 3. MULTIPLE CAPACITORS ARE CONNECTED IN PARALLEL UNLESS OTHERWISE SPECIFIED.
 4. LEAD COLORS ARE OPTIONAL. LEADS MUST ALWAYS BE NUMBERED AS SHOWN.

CD0001

REV. DESC: REVISE TO SHOW OPTIONAL COLORS			
REV. LTR: D	BY: JLP	REVISED: 04/08/99 1:16	TDR: 0178636
100000		FILE: AAA00007405	MDL: -
		MTL: -	

BALDOR ELECTRIC Co.

TYPE L, DV, REV, 6 LEADS