

ABB BALDOR RELIANCE III

Customer information packet

CDPT3603

3HP, 1750RPM, DC, 184ATC, 3649P, TEFC, F1, N

Class - None

Division - Not Applicable

Specifications

Armature Voltage	180 V
Base Speed	1750 rpm
Enclosure	TEFC
Frame	184ATC
Frame Material	Steel
Haz Area Class and Group	None
Output Power	3.000 HP
Agency Approvals	CE CSA UR WEEE
Ambient Temperature	40 °C
Armature Current	14.0 a
Armature Inertia	107.110 lb-ft ²
Base Indicator	Rigid
Bearing Grease Type	Polyrex EM (-20F +300F)
Drip Cover	No Drip Cover
Duty Rating	CONT
Feedback Device	TACHOMETER
Haz Area Division	Not Applicable
Heater Indicator	No Heater
Insulation Class	F
Lifting Lugs	Standard Lifting Lugs
Motor Lead Quantity/Wire Size	2 @ 12 AWG
Motor Lead Termination	Flying Leads
Motor Standards	NEMA
Mounting Arrangement	F1
Overall Length	27.37 IN
Product Family	General Purpose
Pulley End Bearing Type	Sealed Bearing
Service Factor	1.00
Shaft Diameter	1.125 IN

Part Detail

Revision	K
Type	DC
Mech. spec.	36P332
Base	
Status	PRD/A
Elec. spec.	36WGZ507
Layout	36LYP332
Eff. date	03-19-2026
CD Diagram	CD0194
Poles	00
Leads	
Proprietary	False
Created date	06-18-2019

Shaft Ground Indicator

No Shaft Grounding

Shaft Rotation

Reversible

Shaft Slinger Indicator

No Slinger

Nameplate

NP0891L				
CAT.NO.	CDPT3603			
SPEC.	36P332Z507			
HP	3/2.2KW	ENCL	TEFC	
RPM	1750 1/MIN			
FRAME	184ATC	TYPE	3649P	
ARM V	180	ARM A	14	
FLD V		FLD A		
INSUL	F	AMB.	40	
DUTY	CONT	SUPPLY	K	
BRG/DE	6206	BRG/ODE		
BRUSHES	2/BP5031A01			
SER.	BLANK			
BLANK	IP44 KG54 IC411			
APRV-CE	Y	APRV-CSA	Y	APRV-UL Y

ABB Motors and Mechanical Inc.

WINDING # 36WGZ507

3 HP DC 1750 RPM 180 V 3649P

Typical performance - not guaranteed values.

ENCL: TEFC DUTY: CONT CL: F

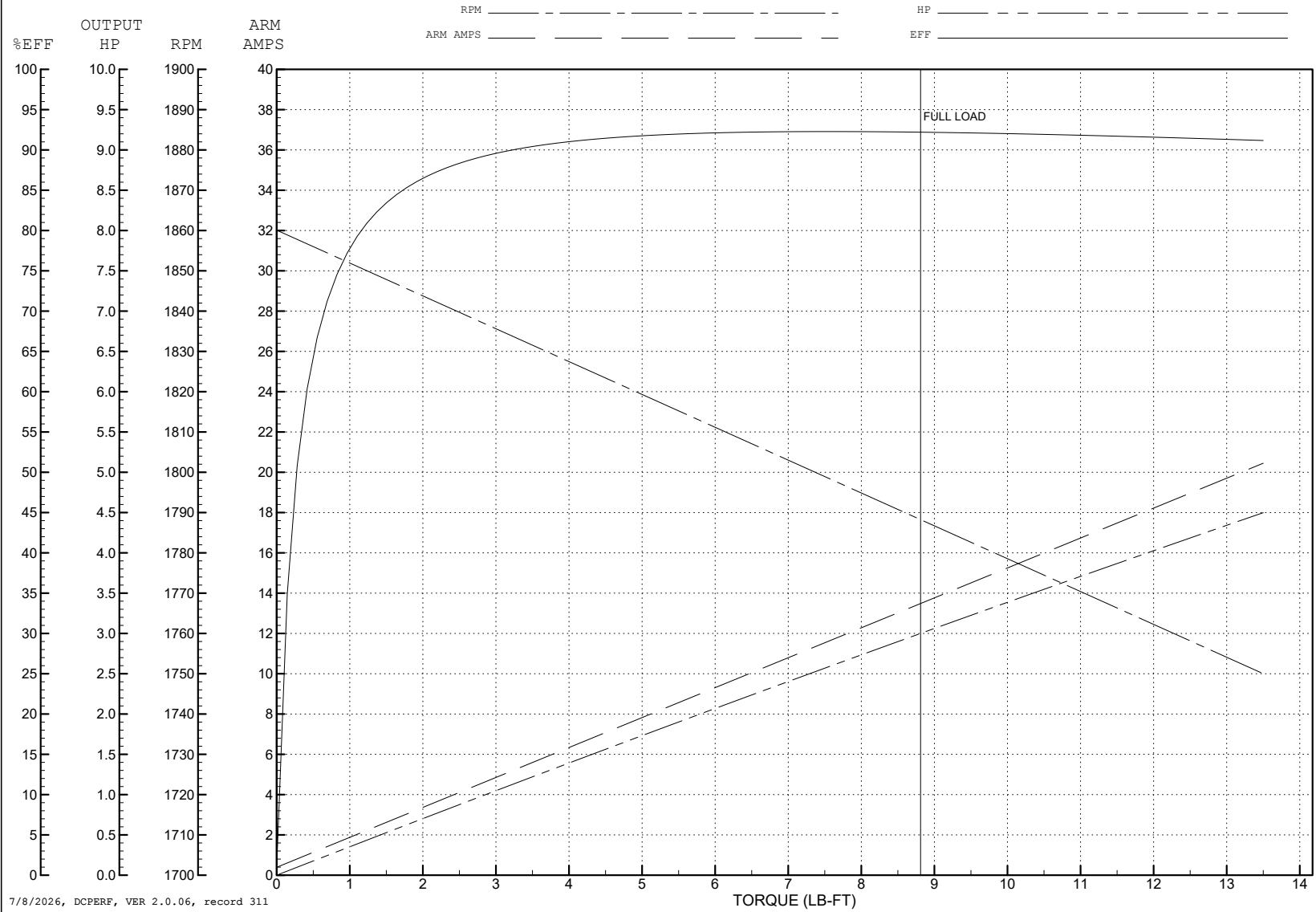

7/8/2026, DCPERF, VER 2.0.06, record 311

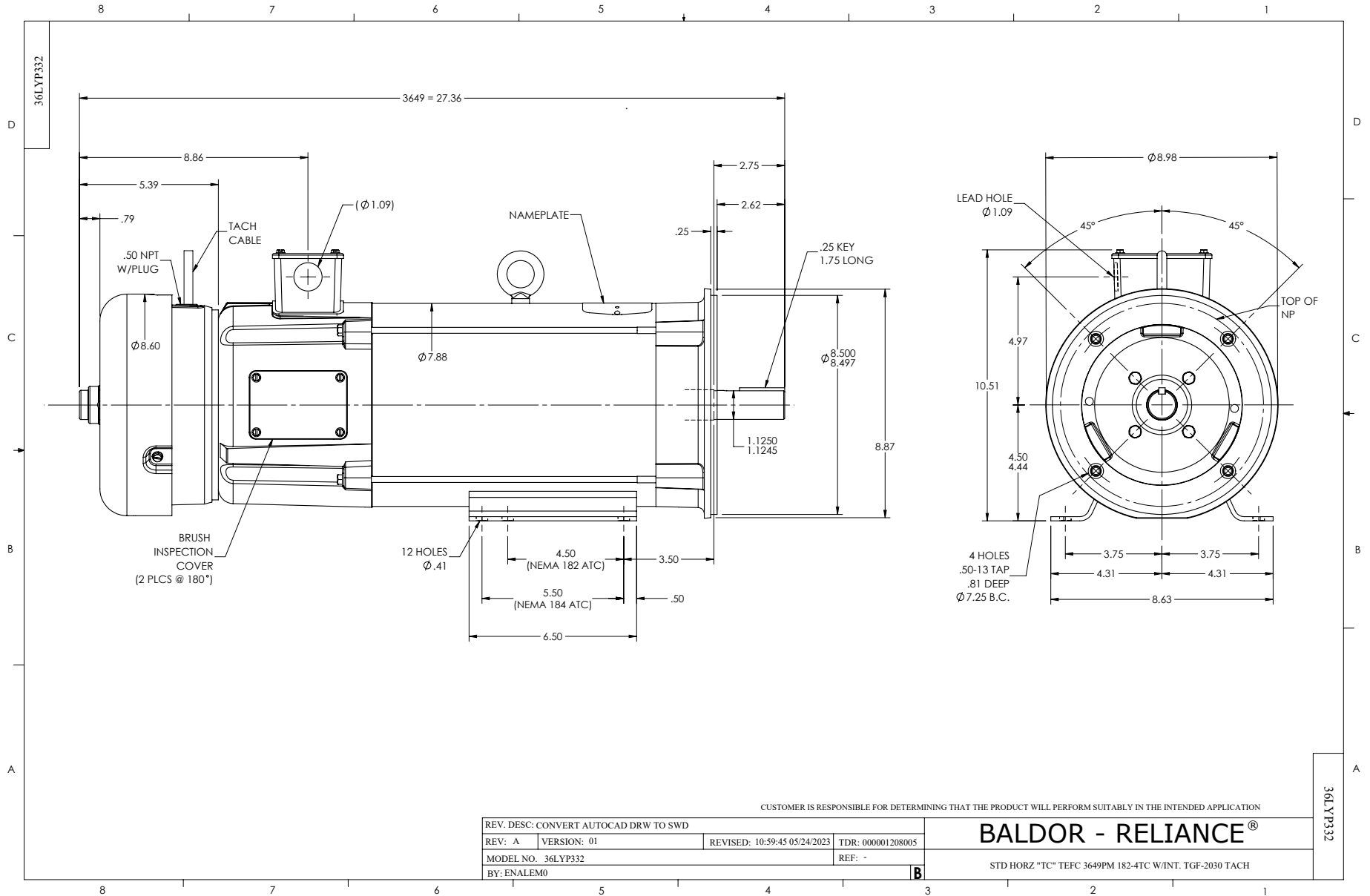

CD0194

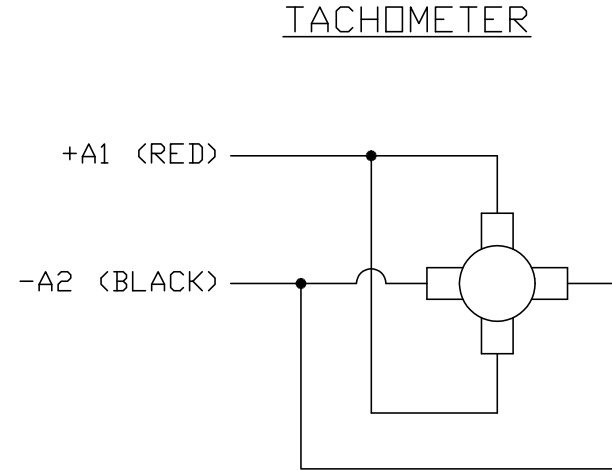
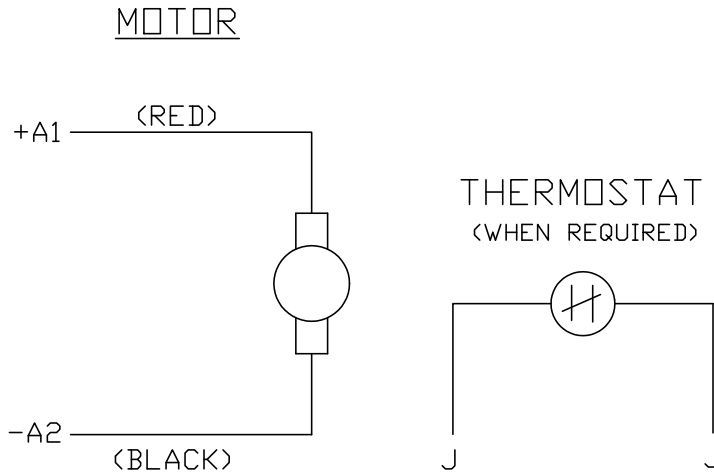

NOTES:

1. CCW ROTATION AS SHOWN FACING COMMUTATOR END. TO REVERSE MOTOR ROTATION OR TACHOMETER OUTPUT POLARITY INTERCHANGE LEADS A1(RED) & A2(BLACK)
2. LEAD COLORS FOR REFERENCE ONLY & NOT SPECIFIED BY THIS DRAWING. LEAD COLORS SPECIFIED BY LAYOUT DRAWING & BILL OF MATERIAL ONLY.

MATL: -			
REV: E	ADDED NOTE "LEAD COLORS FOR REFERENCE ONLY &..."		
761000 CD0194	SCALE: -	BY: CK	REVISED: 07/28/95
	FILE: AAA00004503	TDR: 0078737	

BALDOR ELECTRIC Co.

CD TYPE P DC PERMANENT MAGNET MOTORS AND TACHOMETERS

CD0194