

ABB BALDOR RELIANCE III

Customer information packet

CDPT3575

1.5HP, 1750RPM, DC, 145TC, 3536P, TEFC, F1, N

Class - None

Division - Not Applicable

Specifications

Armature Voltage	180 V
Base Speed	1750 rpm
Enclosure	TEFC
Frame	145TC
Frame Material	Steel
Haz Area Class and Group	None
Output Power	1.500 HP
Agency Approvals	CE CSA UR WEEE
Ambient Temperature	40 °C
Armature Current	7.7 a
Armature Inertia	30.342 lb-ft ²
Base Indicator	Rigid
Bearing Grease Type	Polyrex EM (-20F +300F)
Drip Cover	No Drip Cover
Duty Rating	CONT
Feedback Device	TACHOMETER
Haz Area Division	Not Applicable
Heater Indicator	No Heater
Insulation Class	F
Lifting Lugs	No Lifting Lugs
Motor Lead Quantity/Wire Size	2 @ 14 AWG
Motor Lead Termination	Flying Leads
Motor Standards	NEMA
Mounting Arrangement	F1
Overall Length	19.25 IN
Product Family	General Purpose
Pulley End Bearing Type	Ball
RoHS Status	ROHS COMPLIANT
Service Factor	1.00

Part Detail

Revision	E
Type	DC
Mech. spec.	35P1188
Base	
Status	PRD/A
Elec. spec.	35WGZ164
Layout	35LYP1188
Eff. date	10-28-2024
CD Diagram	CD0194
Poles	00
Leads	
Proprietary	False
Created date	06-19-2019

Shaft Diameter	0.875 IN
Shaft Ground Indicator	No Shaft Grounding
Shaft Rotation	Reversible
Shaft Slinger Indicator	No Slinger

Nameplate

NP0891L			
CAT.NO.	CDPT3575		
SPEC.	35P1188Z164		
HP	1.5/KW1.1	ENCL	TEFC
RPM	1750 1/MIN		
FRAME	145TC	TYPE	3536P
ARM V	180	ARM A	7.7
FLD V		FLD A	
INSUL	F	AMB.	40
DUTY	CONT	SUPPLY	K
BRG/DE	6205	BRG/ODE	6205
BRUSHES	2/BP5000T15		
		BLANK	IP44
SER.			
BLANK	IC411 KG32		
APRV-CE	Y	APRV-CSA	Y
		APRV-UL	Y

ABB Motors and Mechanical Inc.

WINDING # 35WGZ164

1.5 HP DC 1750 RPM 180 V 3536P

Typical performance - not guaranteed values.

ENCL: TEFC DUTY: CONT CL: F

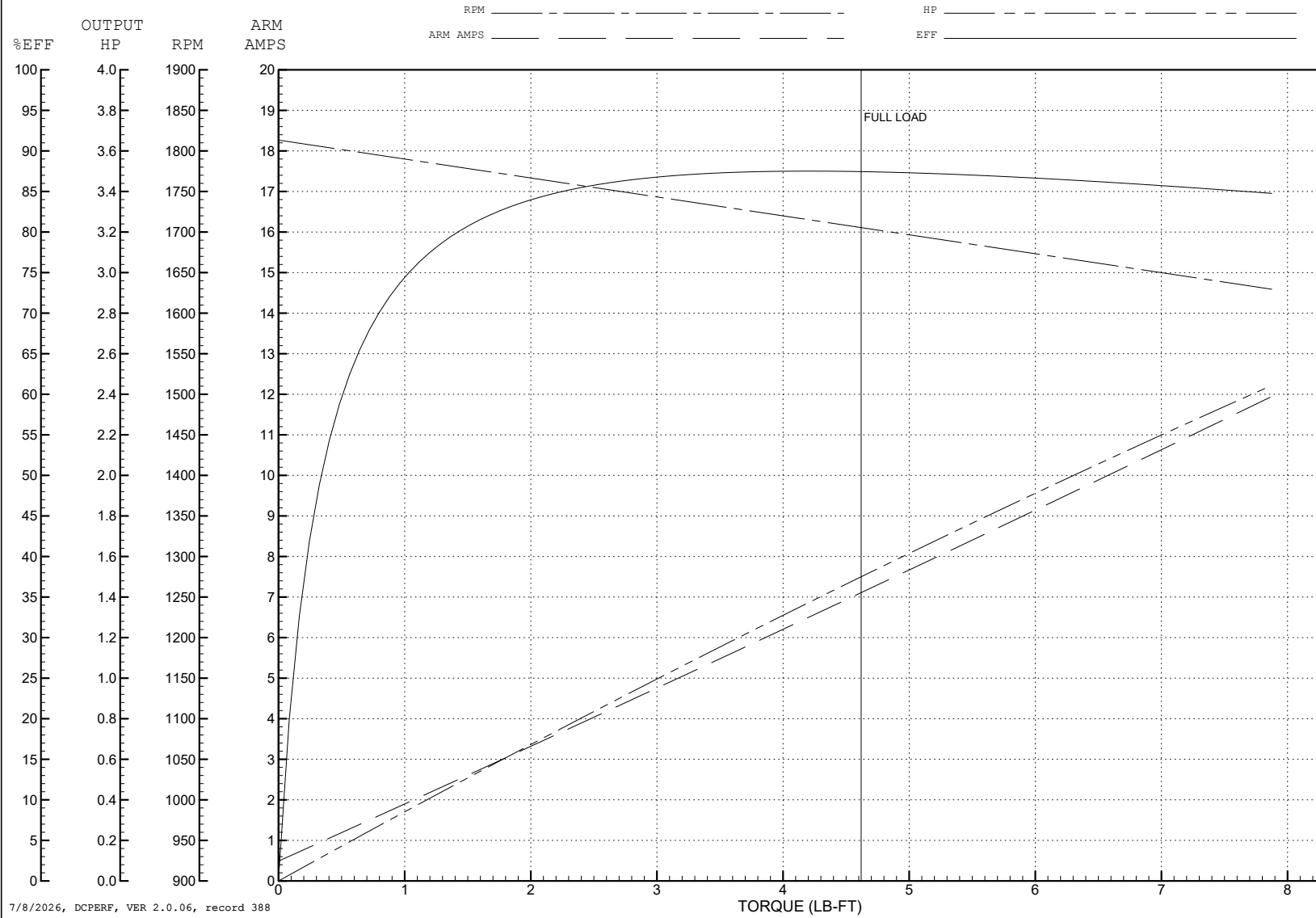

7/8/2026, DCPERF, VER 2.0.06, record 388

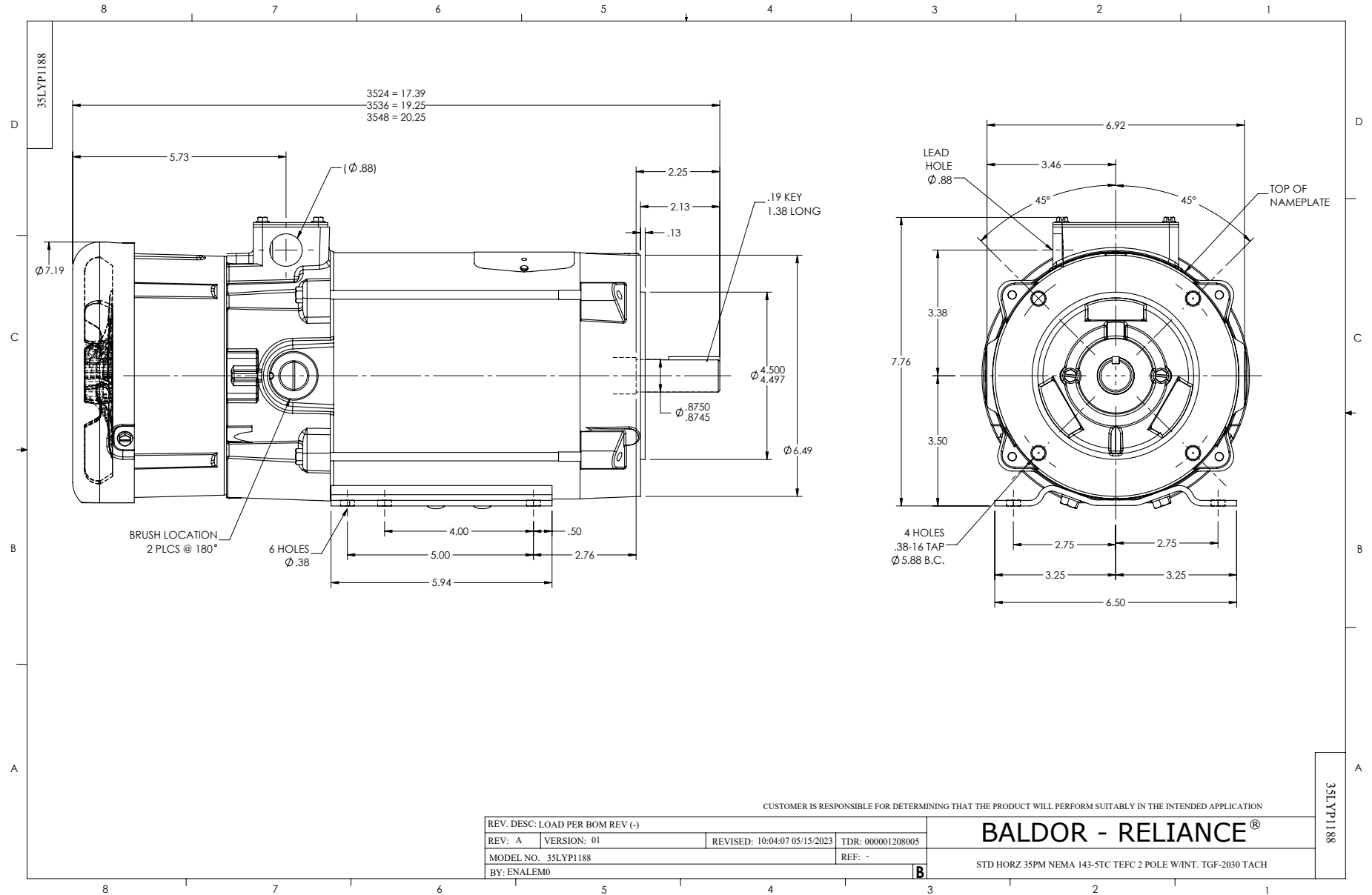

CD0194

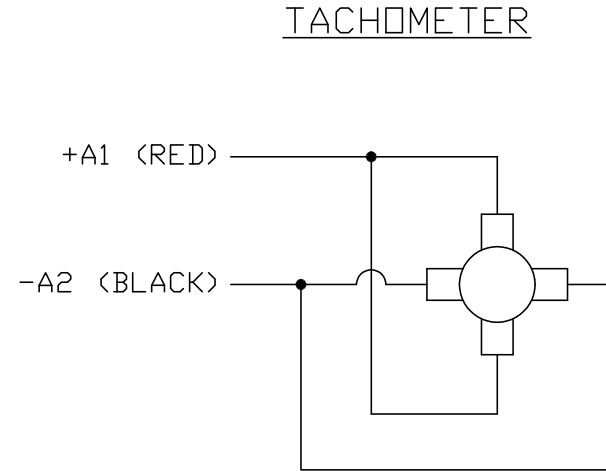
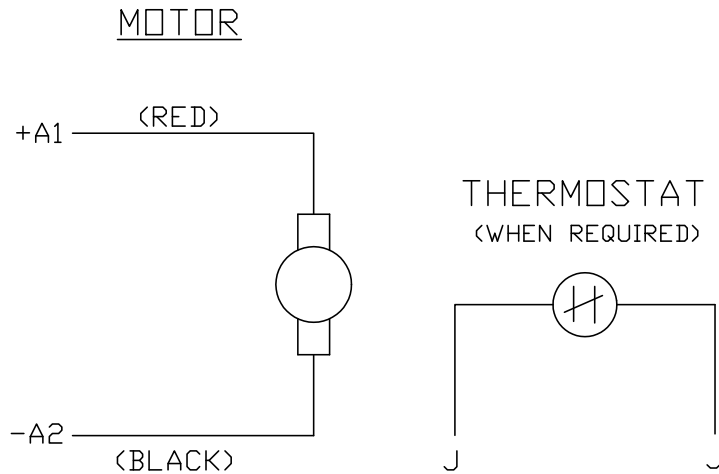

NOTES:

1. CCW ROTATION AS SHOWN FACING COMMUTATOR END. TO REVERSE MOTOR ROTATION OR TACHOMETER OUTPUT POLARITY INTERCHANGE LEADS A1(RED) & A2(BLACK)
2. LEAD COLORS FOR REFERENCE ONLY & NOT SPECIFIED BY THIS DRAWING. LEAD COLORS SPECIFIED BY LAYOUT DRAWING & BILL OF MATERIAL ONLY.

MATL: -			
REV: E	ADDED NOTE "LEAD COLORS FOR REFERENCE ONLY &..."		
CD0194	SCALE: -	BY: CK	REVISED: 07/28/95
	FILE: AAA00004503	TDR: 0078737	

BALDOR ELECTRIC Co.

CD TYPE P DC PERMANENT MAGNET MOTORS AND TACHOMETERS

CD0194