

BALDOR • RELIANCE

Customer information packet

CDPT3436

.75HP, 1750RPM, DC, 56C, 3428P, TEFC, F1, N

Class - None

Division - Not Applicable

Specifications

Armature Voltage	180 V
Base Speed	1750 rpm
Enclosure	TEFC
Frame	56C
Frame Material	Steel
Haz Area Class and Group	None
Output Power	0.750 HP
Agency Approvals	CE CSA UR WEEE
Ambient Temperature	40 °C
Armature Current	3.7 a
Armature Inertia	10.926 lb-ft ²
Base Indicator	Rigid
Bearing Grease Type	Polyrex EM (-20F +300F)
Drip Cover	No Drip Cover
Duty Rating	CONT
Feedback Device	TACHOMETER
Haz Area Division	Not Applicable
Heater Indicator	No Heater
Insulation Class	F
Lifting Lugs	No Lifting Lugs
Motor Lead Quantity/Wire Size	2 @ 14 AWG
Motor Lead Termination	Flying Leads
Motor Standards	NEMA
Mounting Arrangement	F1
Overall Length	16.64 IN
Product Family	General Purpose
Pulley End Bearing Type	Sealed Bearing
RoHS Status	ROHS COMPLIANT
Service Factor	1.00

Part detail

Revision	D
Type	DC
Mech. spec.	34-7842
Base	
Status	PRD/A
Elec. spec.	34WG3946
Layout	34LY7842
Eff. date	10-25-2024
CD Diagram	CD0194
Poles	00
Leads	
Proprietary	False
Created date	06-19-2019

Shaft Diameter	0.625 IN
Shaft Ground Indicator	No Shaft Grounding
Shaft Rotation	Reversible
Shaft Slinger Indicator	No Slinger

Nameplate

NP0891L				
CAT.NO.	CDPT3436			
SPEC.	34-7842-3946			
HP	.75/KW.55	ENCL	TEFC	
RPM	1750 1/MIN			
FRAME	56C	TYPE	3428P	
ARM V	180	ARM A	3.7	
FLD V		FLD A		
INSUL	F	AMB.	40	
DUTY	CONT	SUPPLY	1.5	
BRG/DE	6203	BRG/ODE	6203	
BRUSHES	2/BP5000AW14			
		BLANK		
SER.				
BLANK	IP44 KG20 IC411			
APRV-CE	Y	APRV-CSA	Y	APRV-UL Y

DC Motor Performance Data

Record # 1048

Typical performance - not guaranteed values

Winding: 34WG3946-R001		Type: 3428P	Enclosure: TEFC
Nameplate Data		General Characteristics	
Rated Output (HP)	0.75	Armature Resistance @ 25°C	2.728 Ω
R.P.M.	1750		
Armature Volts	180		
Armature Amps	3.7		
Field Volts		Armature Inductance	27.3166 mH
Field Amps			
Rating - Duty	40C AMB-CONT		
Form Factor	1.5		

Load Characteristics at 180 Armature Volts

Load Point	1	2	3	4	5	6	7
Armature Amps	0.16	1.36	2.56	3.76	5.66	6.72	8.16
R.P.M.	1985	1934	1883	1832	1750	1705	1644
Torque (LB-FT)	0	0.75	1.5	2.25	3.44	4.1	5

ABB Motors and Mechanical Inc.

WINDING # 34WG3946

Typical performance - not guaranteed values.

0.75 HP DC 1750 RPM 180 V 3428P

ENCL: TEFC DUTY: CONT CL: F

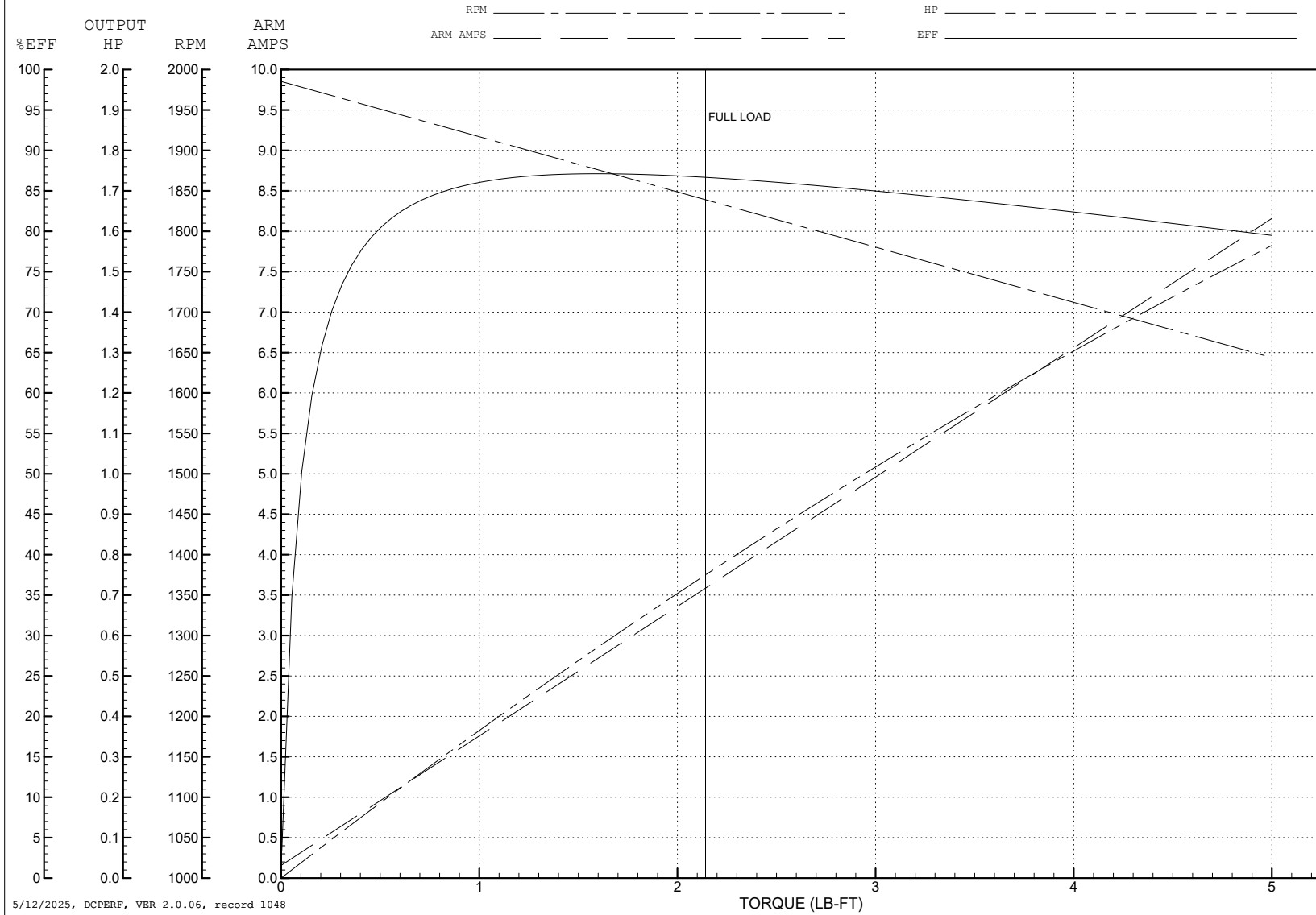

5/12/2025, DCPERF, VER 2.0.06, record 1048

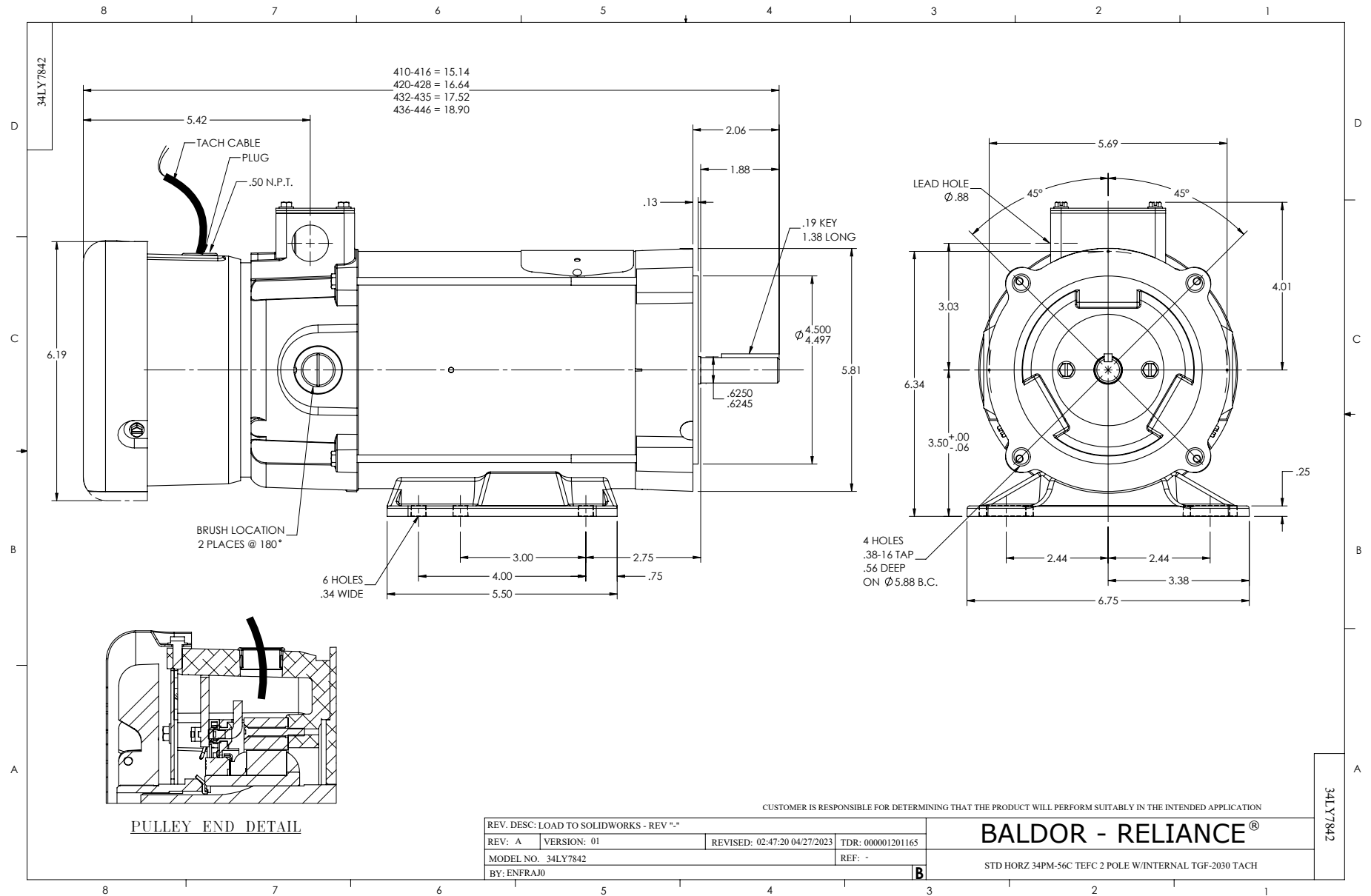

CD0194

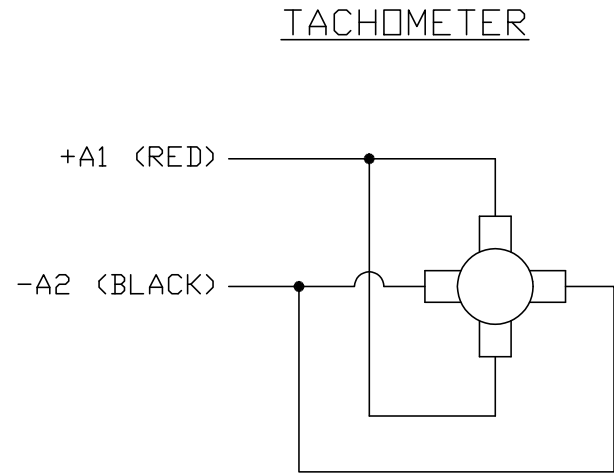
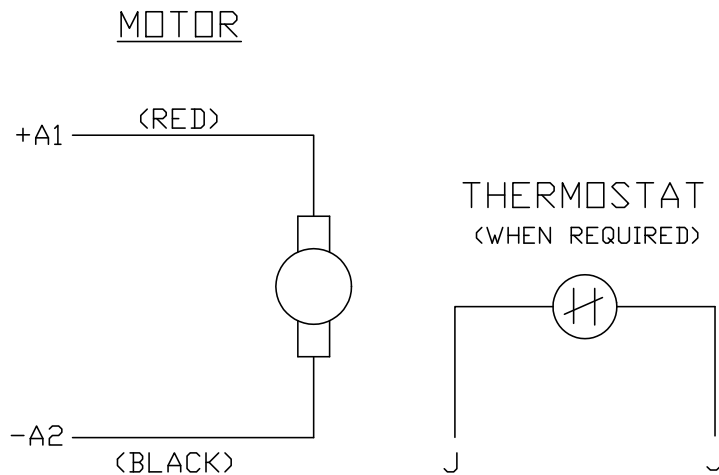

NOTES:

1. CCW ROTATION AS SHOWN FACING COMMUTATOR END. TO REVERSE MOTOR ROTATION OR TACHOMETER OUTPUT POLARITY INTERCHANGE LEADS A1(RED) & A2(BLACK)
2. LEAD COLORS FOR REFERENCE ONLY & NOT SPECIFIED BY THIS DRAWING. LEAD COLORS SPECIFIED BY LAYOUT DRAWING & BILL OF MATERIAL ONLY.

MATL: -			
REV: E	ADDED NOTE "LEAD COLORS FOR REFERENCE ONLY &..."		
CD0194	SCALE: -	BY: CK	REVISED: 07/28/95
	FILE: AAA00004503	TDR: 0078737	

BALDOR ELECTRIC Co.

CD TYPE P DC PERMANENT MAGNET MOTORS AND TACHOMETERS

CD0194