

ABB BALDOR RELIANCE III

Customer information packet

CDPSWD3545

1HP, 1750RPM, DC, 56C, 3536P, TEFC, F1

Class - None

Division -

Specifications

Armature Voltage	90 V
Base Speed	1750 rpm
Enclosure	TEFC
Frame	56C
Frame Material	Stainless Steel
Haz Area Class and Group	None
Output Power	1.000 HP
Agency Approvals	CSA UR
Ambient Temperature	40 °C
Armature Current	9.6 a
Armature Inertia	30.342 lb-ft ²
Base Indicator	Rigid
Bearing Grease Type	Polyrex EM (-20F +300F)
Drip Cover	No Drip Cover
Duty Rating	CONT
Feedback Device	NO FEEDBACK
Heater Indicator	No Heater
Lifting Lugs	No Lifting Lugs
Motor Lead Exit	Ko Box
Motor Lead Quantity/Wire Size	2 @ 14 AWG
Motor Lead Termination	Flying Leads
Motor Standards	NEMA
Mounting Arrangement	F1
Overall Length	16.30 IN
Product Family	Wash Down Paint Free
Pulley End Bearing Type	Sealed Bearing
RoHS Status	ROHS COMPLIANT
Service Factor	1.00
Shaft Diameter	0.625 IN
Shaft Extension Location	Pulley End
Shaft Ground Indicator	No Shaft Grounding

Part Detail

Revision	W
Type	DC
Mech. spec.	35P634
Base	
Status	PRD/A
Elec. spec.	35WGZ235
Layout	35LYP634
Eff. date	04-13-2023
CD Diagram	CD0194
Poles	00
Leads	
Proprietary	False
Created date	01-01-0001

Shaft Rotation

Reversible

Shaft Slinger Indicator

Shaft Slinger

Nameplate

NP1502			
CAT.NO.	CDPSWD3545		
SPEC.	35P634Z235G1		
HP	1	ENCL	TEFC
RPM	1750		
FRAME	56C	TYPE	3536P
ARM V	90	ARM A	9.6
FLD V		FLD A	
INSUL	F	AMB.	40
DUTY	CONT	SUPPLY	K
BRG/DE	6205	BRG/ODE	6205
BRUSHES	2/BP5000T15		
	BLANK		
SER.			
BLANK			
APRV-CSA	APRV-UL		

ABB Motors and Mechanical Inc.

WINDING # 35WGZ235

Typical performance - not guaranteed values.

1 HP DC 1750 RPM 90 V 3536P

ENCL: TEFC DUTY: CONT CL: F

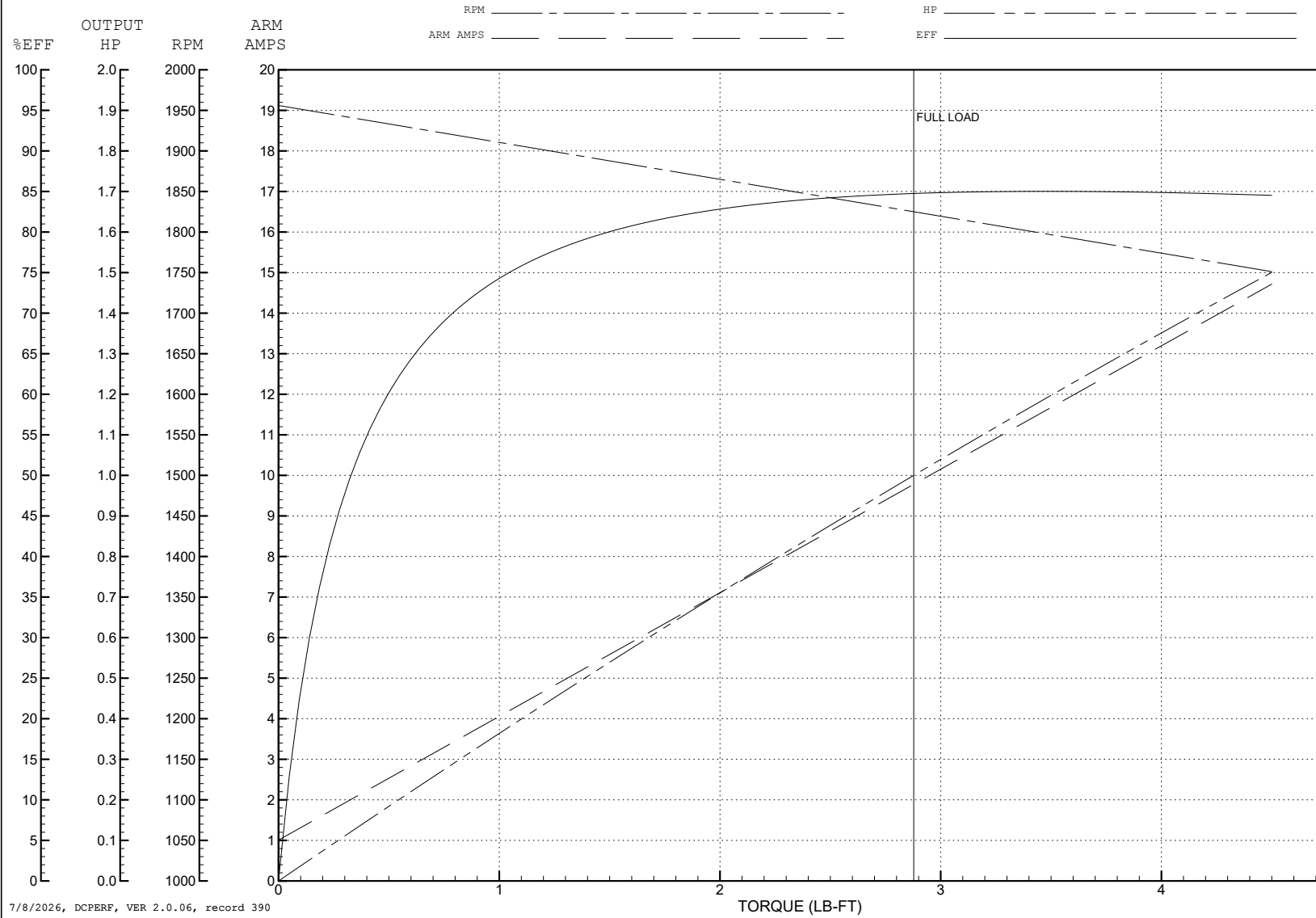

7/8/2026, DCPERF, VER 2.0.06, record 390

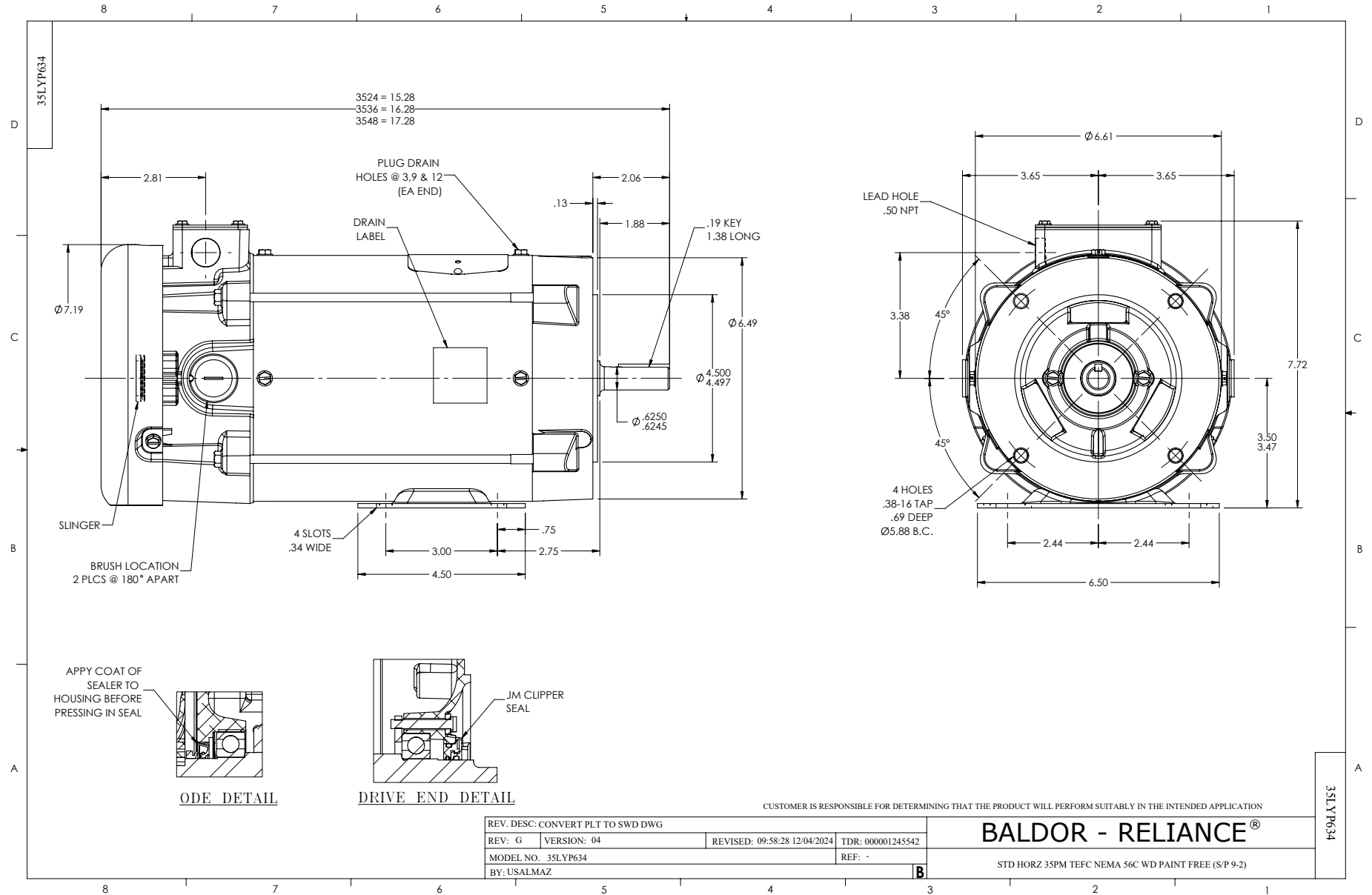

CD0194

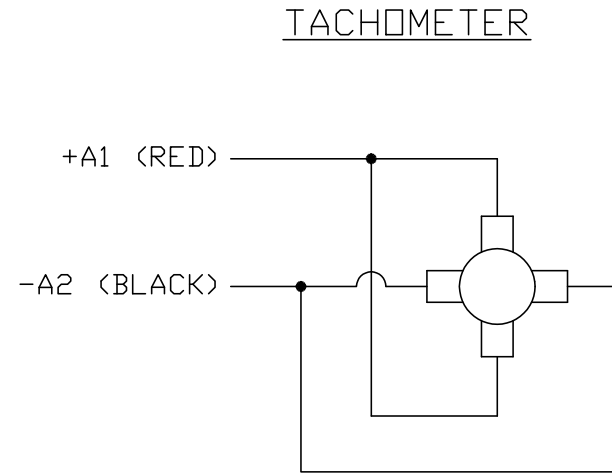
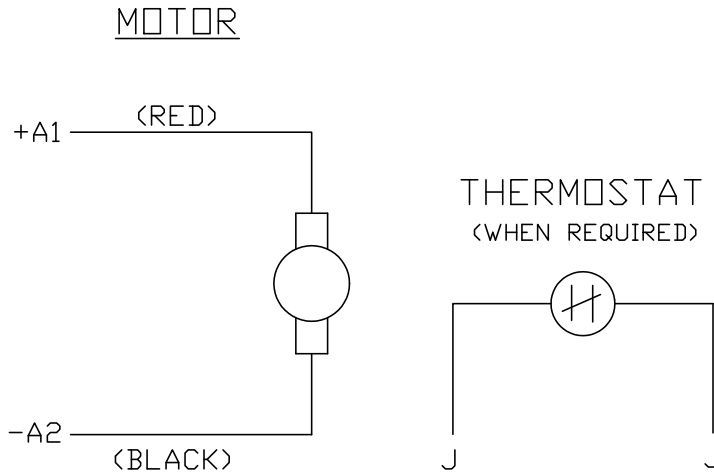

NOTES:

1. CCW ROTATION AS SHOWN FACING COMMUTATOR END. TO REVERSE MOTOR ROTATION OR TACHOMETER OUTPUT POLARITY INTERCHANGE LEADS A1(RED) & A2(BLACK)
2. LEAD COLORS FOR REFERENCE ONLY & NOT SPECIFIED BY THIS DRAWING. LEAD COLORS SPECIFIED BY LAYOUT DRAWING & BILL OF MATERIAL ONLY.

MATL: -			
REV: E	ADDED NOTE "LEAD COLORS FOR REFERENCE ONLY &..."		
761000 CD0194	SCALE: -	BY: CK	REVISED: 07/28/95
	FILE: AAA00004503	TDR: 0078737	

BALDOR ELECTRIC Co.

CD TYPE P DC PERMANENT MAGNET MOTORS AND TACHOMETERS

CD0194