

**BALDOR • RELIANCE**

---

# Customer information packet

## BSM80C-2150AA

SERVOMOTOR WITH RESOLVER

**Specifications**

<b>Enclosure</b>	TENV
<b>Nameplate Speed</b>	2000
<b>Agency Approvals</b>	CE CSA TUV UR WEEE
<b>Base Indicator</b>	Bracket Mounted
<b>Dimensional Drawing Numbers</b>	S2LYP166
<b>Frame</b>	D100D
<b>Frame Material</b>	Steel
<b>Motor Lead Quantity/Wire Size</b>	3 @ 18 AWG
<b>Motor Standards</b>	IEC
<b>Mounting Arrangement</b>	F1
<b>Nameplate Output</b>	0.92KW
<b>Shaft Rotation</b>	Reversible

**Part detail**

<b>Revision</b>	S
<b>Type</b>	AC
<b>Mech. spec.</b>	S2P166
<b>Base</b>	
<b>Status</b>	PRD/A
<b>Elec. spec.</b>	S2WGW078
<b>Layout</b>	S2LYP166
<b>Eff. date</b>	02-13-2024
<b>CD Diagram</b>	CD0006A02
<b>Poles</b>	04
<b>Leads</b>	3#18
<b>Proprietary</b>	False
<b>Created date</b>	01-01-0001

**Nameplate**

<b>NP2864L</b>									
<b>CAT.NO.</b>	BSM80C-2150AA								
<b>BLANK</b>									
<b>SPEC.</b>	S2P166W078G1								
<b>MFG.NO.</b>									
<b>TORQ CONT STALL</b>	2.4 NM								
<b>CUR CONT STALL/A RMS</b>	1.93								
<b>POWER</b>	0.92KW								
<b>RATED SPEED/RPM(1/MIN)</b>	2000								
<b>RATED BUS VOLTS</b>	300								
<b>PEAK CUR/A RMS</b>	5.79								
<b>MAX SPEED/RPM(1/MIN)</b>	7000			<b>AMB.</b>	25				
<b>CLASS</b>	F	IP	54	IC	410	<b>MOTOR MASS</b>	5.4		

S2LYP166

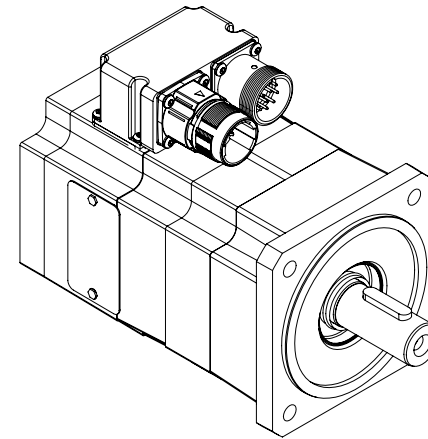
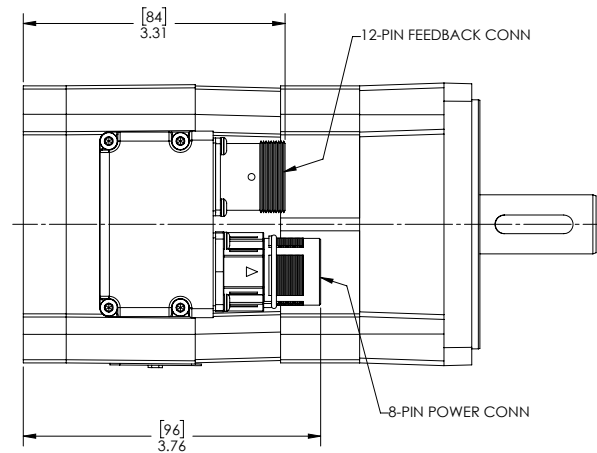
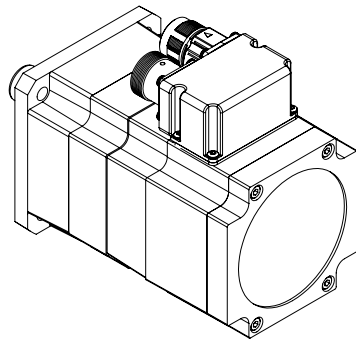

REFERENCE	CODE	A
BSM80C-1	08	5.67 [144.0]
BSM80C-2	16	6.67 [169.4]
BSM80C-3	24	7.67 [194.8]
BSM80C-4	32	8.67 [220.2]

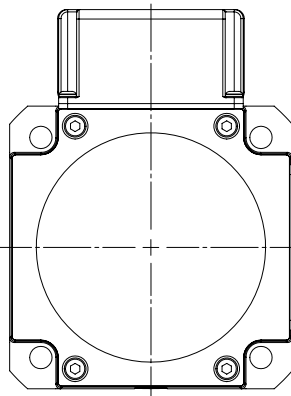

TOL UNLESS SPEC.  
2 PLC INCH DEC. =  
± .06" [1.5mm]  
ANGLES ± 0.5°

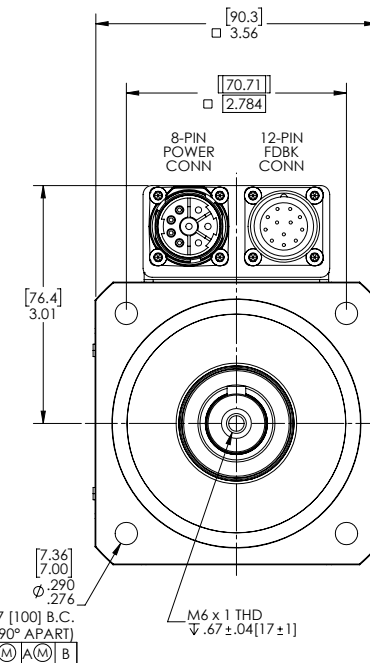
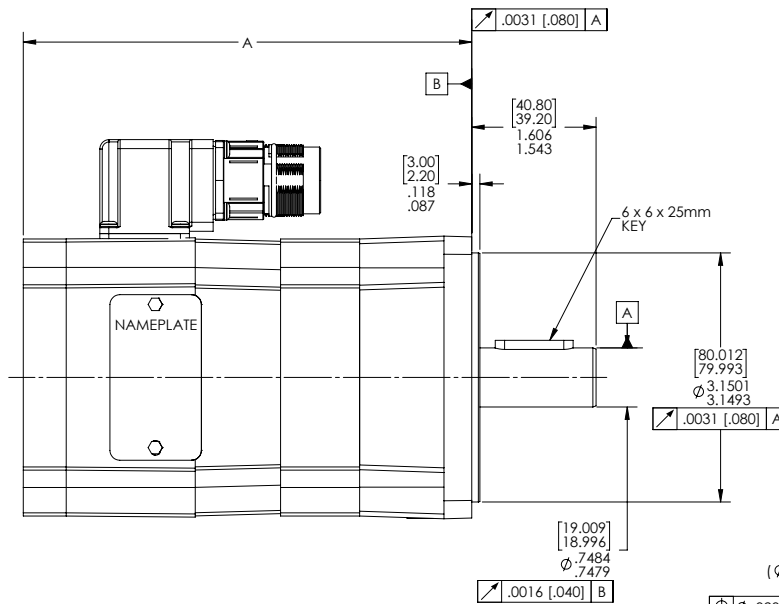

CUSTOMER IS RESPONSIBLE FOR DETERMINING THAT BALDOR'S PRODUCT WILL PERFORM SUITABLY IN THE INTENDED APPLICATION

REV. DESC: LOAD TO SOLIDWORKS	REVISED: 03-09-43 01/30/2018	TDR: 00001059004
REV: G	VERSION: 05	REF: -
MODEL NO. S2LYP166		
BY: ENJEFFD0		

**BALDOR**

BSM80C, 19D100, RESOLVER, M23 CONNECTORS, RING MAGNET

991dATES

991dATES

CD1321

8 PIN THREADED CONNECTOR  
(CRIMP STYLE)  
(INSERTION SIDE)

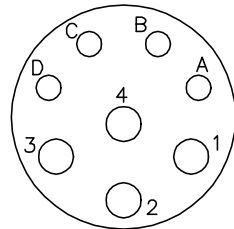

12 PIN THREADED CONNECTOR  
(CRIMP STYLE)  
(INSERTION SIDE)

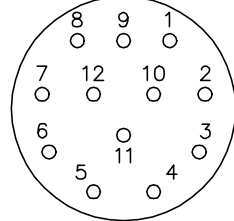

MOTOR CONNECTIONS

PIN	FUNCTION	INTERNAL/EXTERNAL MARKINGS
A	THERMAL SWITCH	YELLOW
B	THERMAL SWITCH	YELLOW
C	BRAKE (OPTIONAL)	BLACK (* RED)
D	BRAKE (OPTIONAL)	BLACK
1	U	BLACK OR T1
2	GROUND	GREEN OR **GREEN/YELLOW
3	W	BLUE OR T3
4	V	RED OR T2

\* WHEN REQUIRED

\*\*CE MOTORS REQUIRE GREEN/YELLOW GROUND

RESOLVER CONNECTIONS

PIN	FUNCTION	INTERNAL WIRE COLOR
1	REF HI R1	RED/WHITE
2	REF LO R2	YELLOW/WHITE
3	COS+ S1	RED
4	COS- S3	BLACK
5	SINE- S4	BLUE
6	SINE+ S2	YELLOW

CD1321

REV. DESC: ADD CE NOTE AND GREEN/YELLOW GROUND

REV. LTR: F

VERSION: 03

TDR: 000001192301

FILE: \AAA\00055\309

REVISED: 02:34:44 06/13/2022

BY: ENDANDO

MTL: -



**BALDOR - RELIANCE®**

BSM WIRING DIAG, POWER & RESOLVER, 8 & 12 PIN THD CONNECT.

SH 1 of 1

CD0006A02

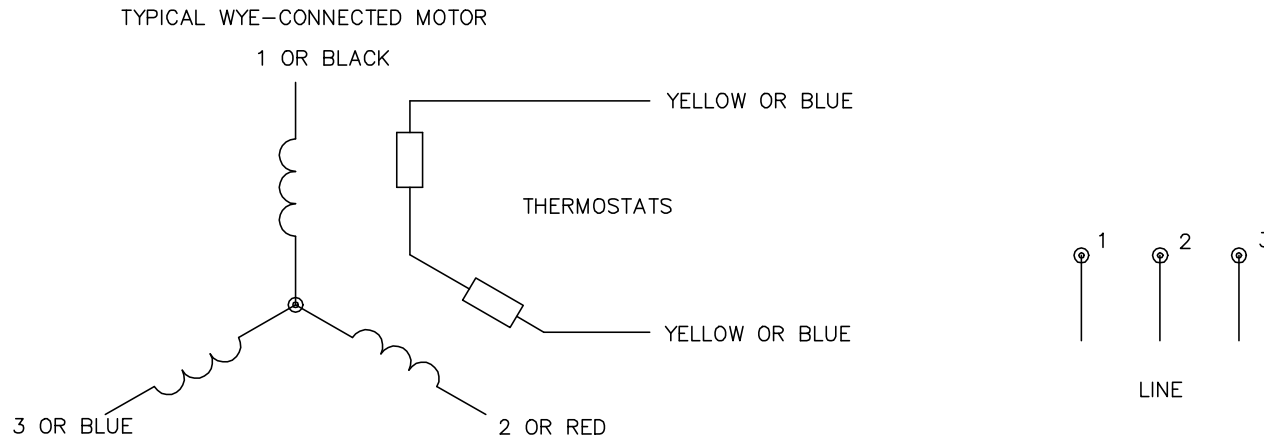

NOTES:

1. INTERCHANGE ANY TWO LINE LEADS TO REVERSE ROTATION.
2. ACTUAL NUMBER OF INTERNAL PARALLEL CIRCUITS MAY VARY.

REV. DESC: REMOVED "OPTIONAL" FROM PRINT, SERVO REQ'S T'STATS		
REV. LTR: D	VERSION: 03	TDR: 000000414937
CD0006A02	FILE: \AAA\00068\606	REVISED: 10:02:28 11/21/2006
	MTL: -	BY: ENJEFO

**BALDOR ELECTRIC Co.**

3PH, SV, 3 LEADS, WYE CONNECTED

CD0006A02