

ABB BALDOR RELIANCE III

Customer information packet

BSM100N-3150AA

BSM100N-3150AA (NEO) T'STAT, RESOLVE

Specifications

Enclosure	TENV
Nameplate Speed	2000
Agency Approvals	CE CSA TUV UR
Base Indicator	Bracket Mounted
Dimensional Drawing Numbers	S4LYP100
Frame	D165D
Frame Material	Exposed Laminations
Motor Lead Quantity/Wire Size	3 @ 10 AWG
Motor Standards	IEC
Mounting Arrangement	F1
Nameplate Output	4.38KW
Shaft Rotation	Reversible

Part Detail

Revision	AH
Type	AC
Mech. spec.	S4P100
Base	
Status	PRD/A
Elec. spec.	S4WGW059
Layout	S4LYP100
Eff. date	05-19-2026
CD Diagram	CD0006A02
Poles	08
Leads	3#10
Proprietary	False
Created date	01-01-0001

Nameplate

NP2863L				
CAT.NO.				
SPEC.	S4P100W059G1			
MFG.NO.				
TORQ CONT STALL	34 NM			
CUR CONT STALL/A RMS	23			
POWER	3.64KW			
RATED SPEED/RPM(1/MIN)	2000			
RATED BUS VOLTS	320			
PEAK CUR/A RMS	92			
MAX SPEED/RPM(1/MIN)	4000			
IP	54	IC	410	WT. 31.3
CLASS	F	25C RATED		

Accessories

Part number	Description	Multiplier
GBSM100-MRP120-3	Std. Servo Gearbox Ratio 3:1	E4
GBSM100-MRP155-5	Std. Servo Gearbox Ratio 5:1	E4

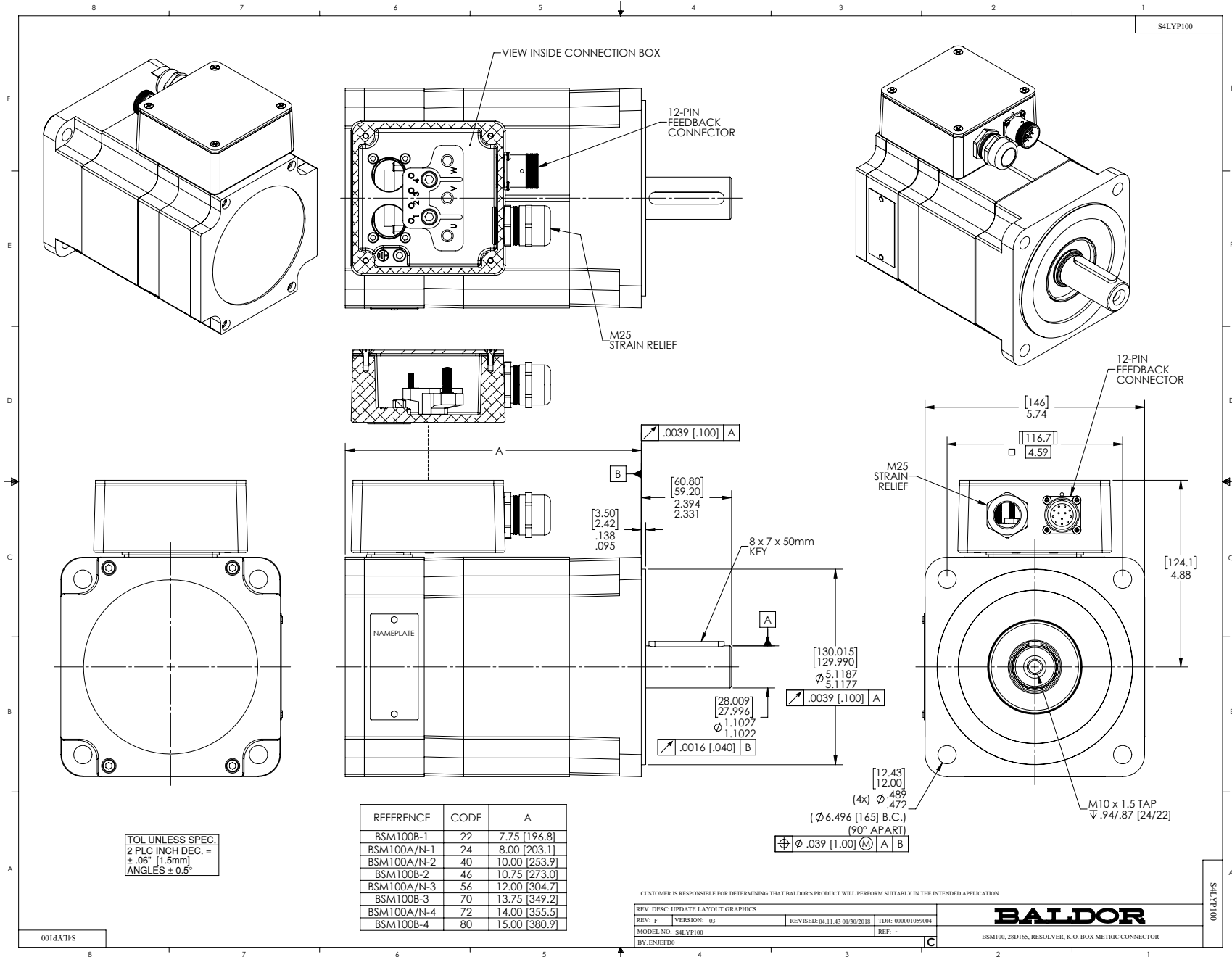

CD1404

MOTOR CONNECTIONS

TERMINAL LABEL	FUNCTION	INTERNAL WIRE MARKING
1	THERMAL SWITCH	YELLOW
2	THERMAL SWITCH	YELLOW
3	BRAKE (OPTIONAL)	BLACK
4	BRAKE (OPTIONAL)	BLACK
⊥	GROUND	-----
U	PHASE U	T1
V	PHASE V	T2
W	PHASE W	T3

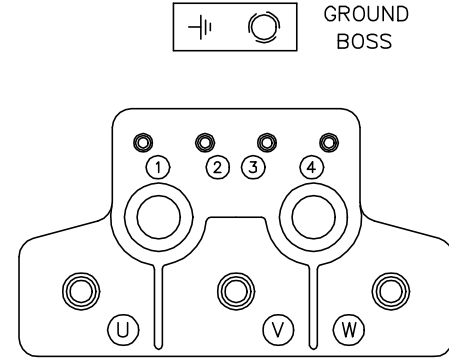

RESOLVER CONNECTIONS

PIN	FUNCTION	INTERNAL WIRE COLOR
1	REF HI R1	RED/WHITE
2	REF LO R2	YELLOW/WHITE (or) BLACK/WHITE
3	COS+ S1	RED
4	COS- S3	BLACK
5	SINE+ S2	BLUE
6	SINE- S4	YELLOW

12 PIN THREADED CONNECTOR
(INSERTION SIDE)

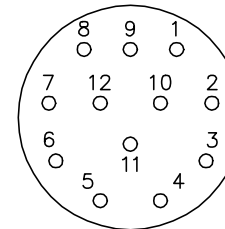

NOTE:

IF NO FEEDBACK, OMIT RESOLVER CONNECTIONS.

REV. DESC: ADDED OPTIONAL BLACK/WHITE COLOR TO REF-LO-R2		
REV. LTR: B	VERSION: 01	TDR: 000001151947
FILE: \AAA\00065\150	REVISED: 01:18:21 10/27/2020	BY: ENJFDO
MTL: -		© □

BALDOR - RELIANCE®

CONN. DIAG.-BSM,RESOLVER,BRAKE,TERMINAL BLOCK,12 PIN CONN

SH 1 of 1

CD1404

CD0006A02



NOTES:

1. INTERCHANGE ANY TWO LINE LEADS TO REVERSE ROTATION.
2. ACTUAL NUMBER OF INTERNAL PARALLEL CIRCUITS MAY VARY.

REV. DESC: REMOVED "OPTIONAL" FROM PRINT, SERVO REQ'S T'STATS		
REV. LTR: D	VERSION: 03	TDR: 000000414937
CD0006A02	FILE: \AAA\00068\606	REVISED: 10:02:28 11/21/2006
	MTL: -	BY: ENJFDO

BALDOR ELECTRIC Co.

3PH, SV, 3 LEADS, WYE CONNECTED

CD0006A02