

ABB BALDOR RELIANCE III

Customer information packet 812RE

.75HP, 3600RPM, 1PH, 60HZ, 3524C, GRND

Specifications

Enclosure	TENV
Frame Material	Steel
Frequency	60.00 Hz 60.00 Hz
Motor Letter Type	Oil Capacitor Start and Run
Nameplate Output	.75
Number of Poles	2 2
Output @ Frequency	.750 HP @ 60 HZ
Phase	1 1
Product Style	GRINDER
Speed	3600 rpm 3600 rpm
Synchronous Speed @ Frequency	3600 RPM @ 60 HZ
Voltage	115 V 230 V
Voltage @ Frequency	230.0 V @ 60 HZ 115.0 V @ 60 HZ
Agency Approvals	CSA
Ambient Temperature	40 °C
Base Indicator	Rigid
Bearing Grease Type	Polyrex EM (-20F +300F)
Current @ Voltage	2.400 A @ 230.0 V 4.800 A @ 115.0 V
Duty Rating	CONT
Feedback Device	NO FEEDBACK
Insulation Class	B
KVA Code	-
Motor Lead Quantity/Wire Size	4 @ 18 AWG
Motor Standards	Other
Motor Type	3524C

Part Detail

Revision	BF
Type	AC
Mech. spec.	G8-212
Base	
Status	PRD/A
Elec. spec.	G8WG0011
Layout	G8LY0212
Eff. date	08-05-2025
CD Diagram	CD0279
Poles	02
Leads	4#18
Proprietary	False
Created date	08-08-2007

Mounting Arrangement	F1
Overall Length	23.24 IN
Product Family	Grinder
Service Factor	1.00
Shaft Extension Location	Double Shaft
Shaft Rotation	Fixed Opposite Standard
Shaft Slinger Indicator	No Slinger
Speed Code	Single Speed
Starting Method	Direct on line
Thermal Device - Winding	None

Nameplate

NP3118			
CAT.NO.	812RE		
HP	.75	VOLTS	115/230
PHASE	1	AMPS	4.8/2.4
HZ	60	RPM	3600
SER.NO			
SPEC.	G8-212-11		

Accessories

Part number	Description	Multiplier
GA16RE	PEDESTAL LIGHT INDUSTRIAL,STEEL-RED	A8
GA14R	PEDESTAL FABRICATED STEEL W/SHELVES-RED	A8
GA16R	PEDESTAL IND., CAST IRON 6" - 10" RED	A8
B80	8" 36 GRIT GRINDING WHEEL	A8
B81	8" 60 GRIT GRINDING WHEEL	A8
GA9R	PAIR LIGHTED EYESHIELDS-RED	A8
GA9SR	PAIR LIGHTED EYESHIELD W/ON-OFF-RED	A8
DC8	DUST CONTROL UNIT	A8
BQ1-015-CC	1PH Brake, NEMA 1,110-125 VAC, 50/60Hz	P1
BQ1-015-CP	1PH Brake, Panel 110-125 VAC, 50/60 Hz	

GBLY0212

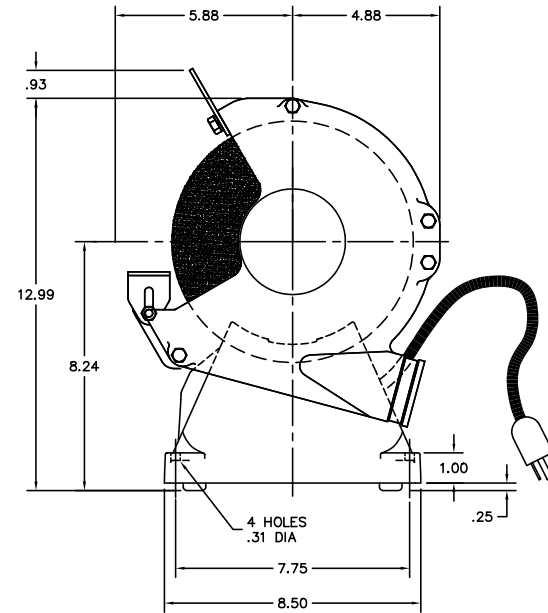
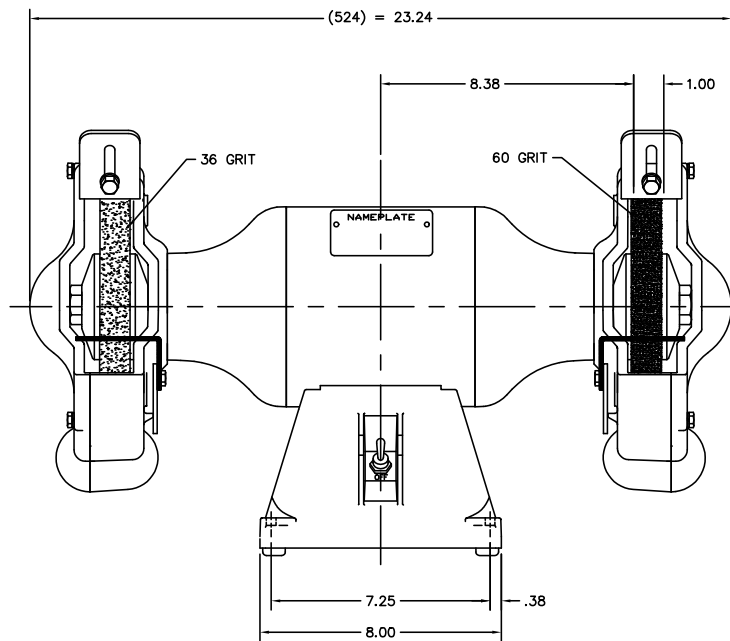

CUSTOMER IS RESPONSIBLE FOR DETERMINING THAT MOTOR PERFORMANCE IS SUITABLE IN THE APPLICATION.

REV. DESC:	OMITTED FELT WSHR HA1025A03 & CHG'D TO SEALED BRGS
REV. LTR:	H BY: SSS REVISED: 10/02/00 1:39 TDR: 0212666
FILE:	AAA00036238 REF: -
MTL:	-

BALDOR ELECTRIC Co.

STD 8" UTILITY GRINDER 524C W/115V CORD/PLUG

GBLY0212

