

BALDOR • RELIANCE

Customer information packet

8107WD

.75HP, 3600RPM, 1PH, 60HZ, 3524C, GRND

Specifications

Frequency	60.00 Hz
Nameplate Output	.75
Number of Poles	2
Phase	1
Product Style	GRINDER
Speed	3600 rpm
Voltage	115 V 230 V

Part detail

Revision	BJ
Type	AC
Mech. spec.	G8-231
Base	
Status	PRD/A
Elec. spec.	G8WG0011
Layout	G8LY0231
Eff. date	10-04-2022
CD Diagram	CD0279
Poles	02
Leads	4#18 9"FROM ENDTURNS Y
Proprietary	False
Created date	08-08-2007

Nameplate

NP3118			
CAT.NO.	8107WD		
HP	.75	VOLTS	115/230
PHASE	1	AMPS	4.8/2.4
HZ	60	RPM	3600
SER.NO			
SPEC.	G8-231-11		

Accessories

Part number	Description	Multiplier
GA16	PEDESTAL INDUSTRIAL, CAST IRON 6" - 10"	A8
GA14	PEDESTAL FABRICATED STEEL W/SHELVES	A8
GA20	PEDESTAL INDUSTRIAL, CAST IRON 8"-14"	A8
GA20E	PEDESTAL LIGHT INDUSTRIAL,STEEL	A8
B80	8" 36 GRIT GRINDING WHEEL	A8
B81	8" 60 GRIT GRINDING WHEEL	A8
GA9	PAIR LIGHTED EYESHIELDS	A8
GA9-1	SINGLE LIGHTED EYESHIELD	A8
GA9S	PAIR EYESHIELDS W/ ON-OFF SWITCH	A8
GA11	PAIR EYESHIELDS	A8
DC8	DUST CONTROL UNIT	A8
BQ1-015-CC	1PH Brake, NEMA 1,110-125 VAC, 50/60Hz	
BQ1-015-CP	1PH Brake, Panel 110-125 VAC, 50/60 Hz	
BQ2-015-CC	1PH Brake,NEMA 1 208-230 VAC,50/60Hz	
BQ2-015-CP	1PH Brake, Panel 208-230 VAC, 50/60 Hz	

GBLY0231

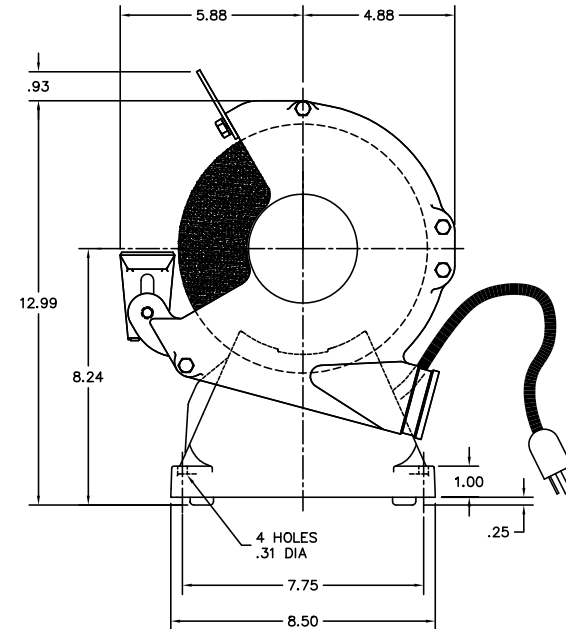
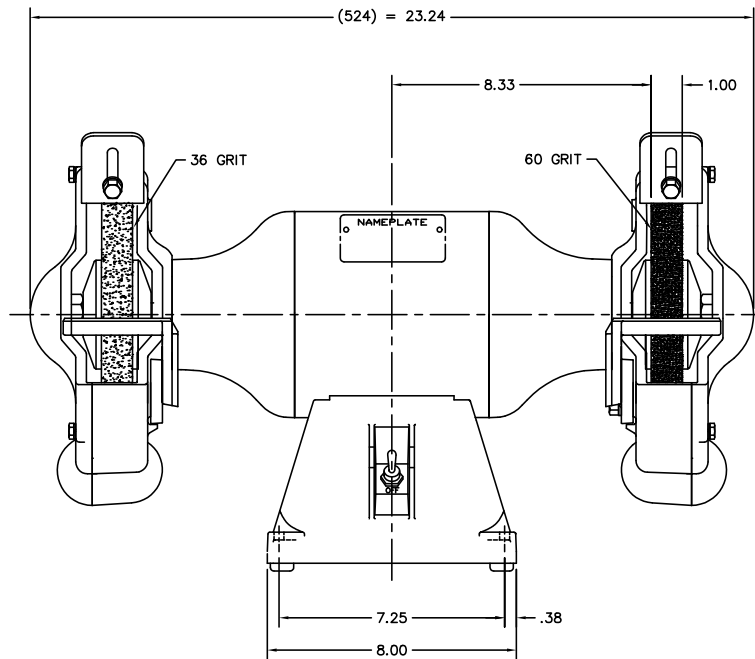

CUSTOMER IS RESPONSIBLE FOR DETERMINING THAT MOTOR PERFORMANCE IS SUITABLE IN THE APPLICATION.

REV. DESC:	OMITTED FELT WSHR HA1025A03 & CHG'D TO SEALED BRGS
REV. LTR:	K BY: SSS REVISED: 09/29/00 2:15 TDR: 0212666
FILE:	AAA00036180 REF: -
MTL:	-

BALDOR ELECTRIC Co.

STD 8" GRINDER 524C W/115V. CORD/PLUG, TOOL TRAY, WATER POT

GBLY0231

