

BALDOR • RELIANCE

Customer information packet 1457

5HP, 1000/1200RPM, 3PH, 50/60HZ, 3744M, BUFF

Specifications

Frequency	50.00 Hz
	60.00 Hz
Nameplate Output	5
Number of Poles	6
Phase	3
Product Style	GRINDER
Speed	1000 rpm
	1200 rpm
Voltage	208 V
	230 V
	460 V

Part detail

Revision	X
Type	AC
Mech. spec.	G14-117
Base	
Status	PRD/A
Elec. spec.	G4WG0039
Layout	G4LY0117
Eff. date	02-11-2022
CD Diagram	CD0258
Poles	06
Leads	9#14 11"FROM ENDTURN Y
Proprietary	False
Created date	01-01-0001

Nameplate

NP3411L			
CAT.NO.	1457		
HP	5	VOLTS	230
PHASE	3	AMPS	15.2
HZ	50//60	RPM	1000//1200
SER.NO			
SPEC.	G14-117B-0039G1		
BLANK			

Accessories

Part number	Description	Multiplier
GA20	PEDESTAL INDUSTRIAL, CAST IRON 8"-14"	A8

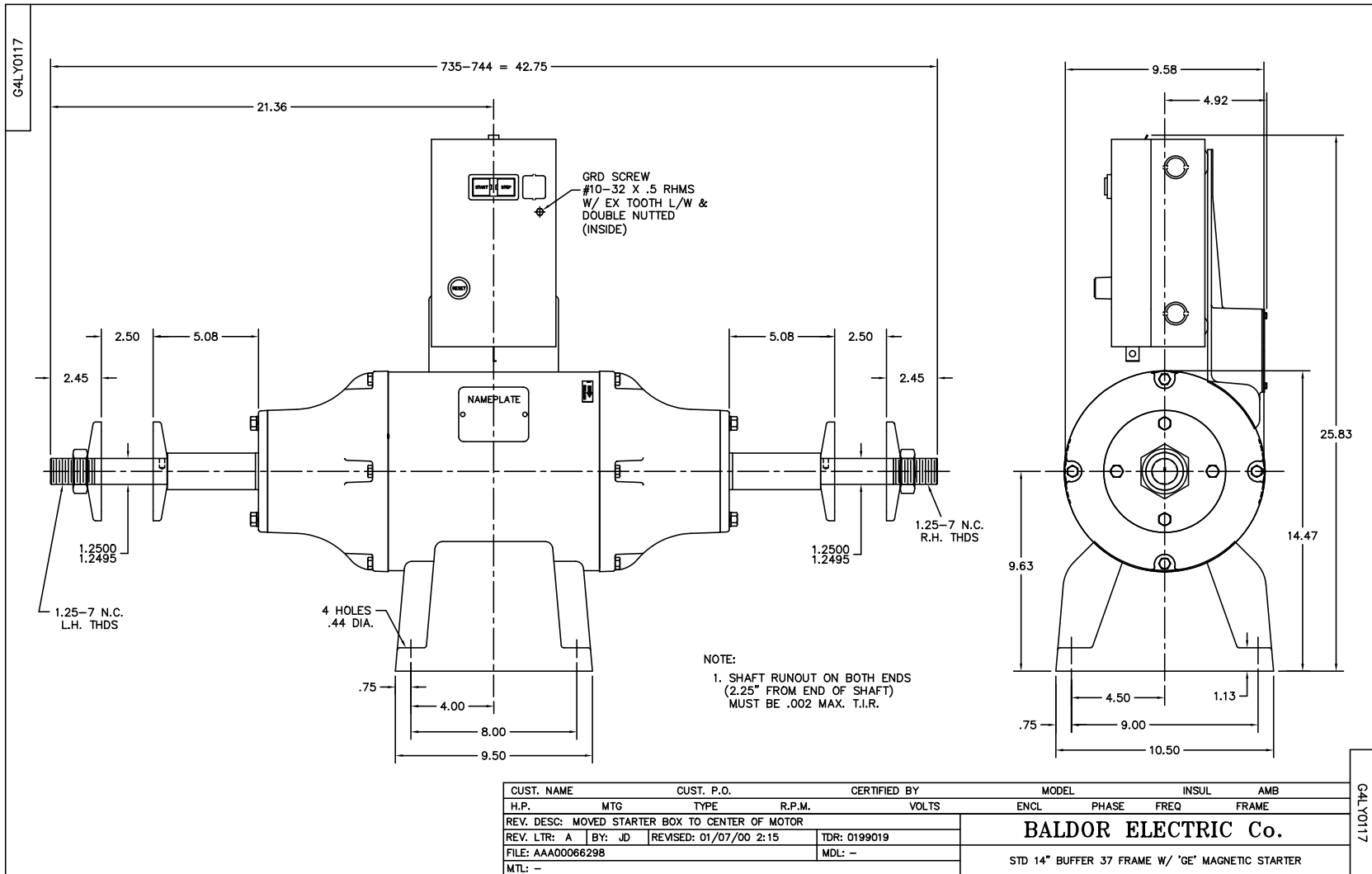

CD0258

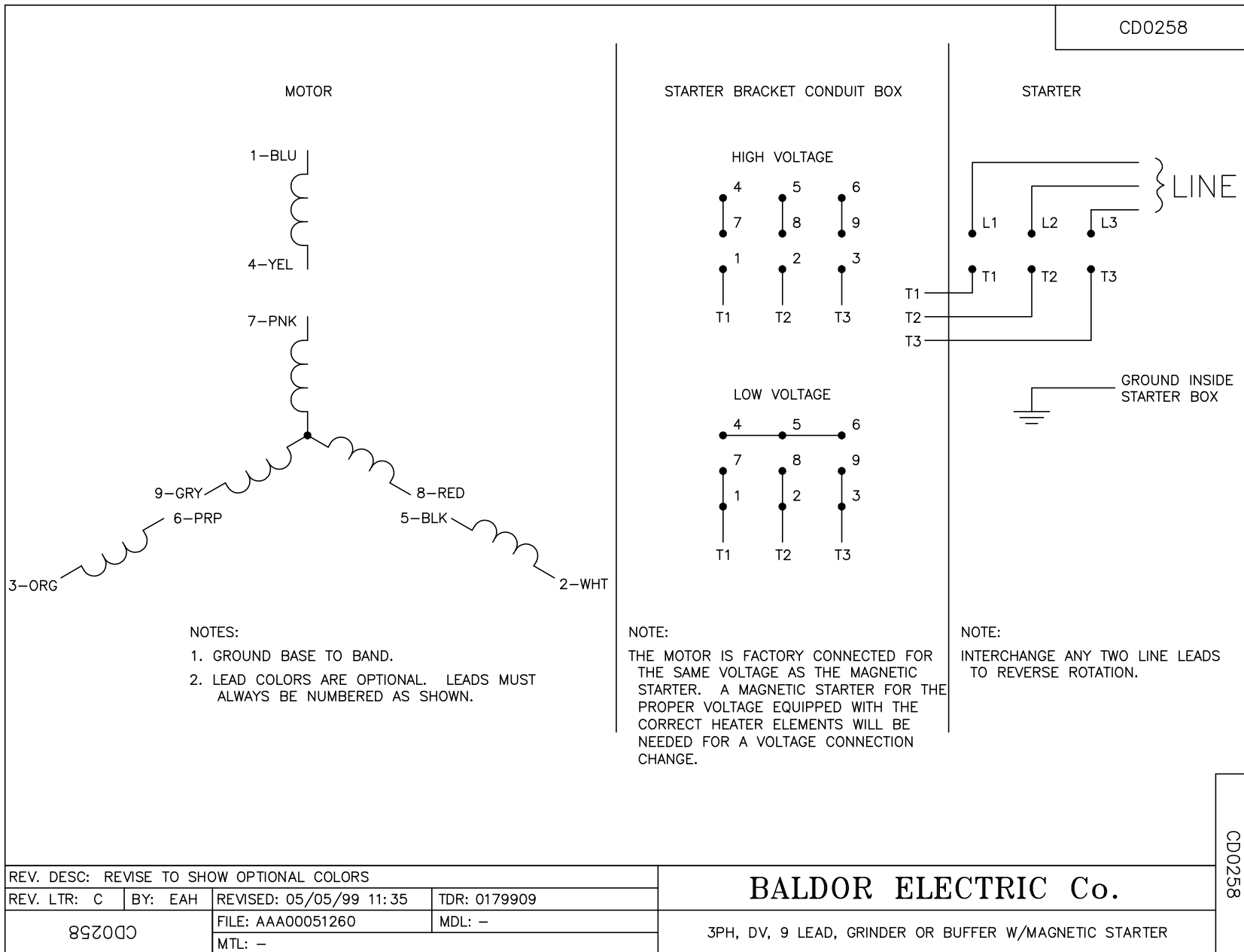

CD0258

REV. DESC: REVISE TO SHOW OPTIONAL COLORS			
REV. LTR: C	BY: EAH	REVISED: 05/05/99 11:35	TDR: 0179909
89Z0C0		FILE: AAA00051260	MDL: -
		MTL: -	

BALDOR ELECTRIC Co.

3PH, DV, 9 LEAD, GRINDER OR BUFFER W/MAGNETIC STARTER