



Series 30
Line Regenerative
Digital DC Control

Installation & Operating Manual

Table of Contents

Section 1	
Quick Start	1-1
Minimum Connection Requirements	1-1
Power and Motor Connections	1-1
Reference and Jumpers for Keypad Operation	1-1
Parameter Settings (for Keypad Operation)	1-1
Reference and Jumpers for Remote Operation	1-2
Speed Feedback	1-2
Serial Link	1-2
Section 2	
General Information	2-1
Overview	2-1
CE Compliance	2-1
Enclosure Sizes	2-1
Limited Warranty	2-1
Product Notice	2-2
Safety Notice	2-2
Section 3	
Getting Started	3-1
Control Overview	3-1
Control Loops	3-1
Control and Communications	3-1
Local and Remote Modes	3-2
Source / Destination Tags	3-3
Programming Block	3-4
Section 4	
Receiving and Installation	4-1
Receiving & Inspection	4-1
Location Considerations	4-1
Cover Removal	4-2
Mechanical Installation	4-3
External Vent Kit	4-3
Optional Remote Keypad Installation	4-4
Electrical Installation	4-5
System Grounding	4-5
Line Impedance	4-5
Power Disconnect	4-5
Protection Devices	4-5
Isolation Transformer Sizing	4-6
Single Phase Power	4-6
Power Connections	4-8
Logic Power	4-8
Motor Connections	4-9
M-Contactor	4-11

Blower Motor Starter	4-12
Thermal Protection	4-13
Encoder Installation	4-13
Tachometer Installation	4-14
Control I/O Signal Connections	4-15
Analog Inputs	4-15
Analog Outputs	4-16
Digital Inputs	4-16
Digital Outputs	4-17
RS232 Connections	4-18
System Port (P3) Configuration	4-18
Section 5	
Switch Setting and Start-Up	5-1
Pre-Operation Checks	5-1
Power up in Local Mode with Armature Feedback	5-1
Power up in Remote Mode with Feedback	5-5
Autotune	5-12
Speed Loop Adjustment	5-13
Starting and Stopping Methods	5-13
Upload/Download Procedure	5-17
DUMP Procedure	5-18
Section 6	
Programming	6-1
Overview	6-1
Menu System	6-1
Parameter Descriptions	6-4
Analog Inputs	6-4
Analog Outputs	6-6
AUX I/O	6-8
Block Diagram	6-11
Calibration	6-12
Configure Drive	6-14
Current Loop	6-15
Current Profile	6-17
Diagnostics	6-18
Digital Inputs	6-21
Digital Outputs	6-25
Field Control	6-26
Alarms	6-28
Jog/Slack	6-29
Menus	6-30
OP Station	6-31

Password	6-31
PID	6-32
Raise/Lower	6-34
Ramps	6-35
Setpoint Sum 1	6-38
Speed Loop	6-39
Advanced	6-41
Standstill	6-42
Stop Rates	6-43
System Port P3	6-48
5703 Support	6-51
TEC Option	6-52
Section 7	
Keypad Operation	7-1
Keypad	7-1
Keypad LED Status	7-2
Alarm Messages	7-2
Local Menu	7-3
L/R Key	7-3
PROG Key	7-3
Menu System	7-4
Menu Shortcuts and Special Key Combinations	7-6
Quick Tag Information	7-6
Restore Factory Settings	7-6
3 button reset	7-7
Operation Examples	7-8
Select a Menu View Level	7-8
Language Selection	7-8
Password Protection	7-9
Deactivate a Password	7-10
Save Settings	7-11
Section 8	
Troubleshooting	8-1
Reset a Trip Condition	8-1
Fault Conditions	8-1
Serial (P3) Errors	8-1
Alarm Messages	8-2
Last Alarm	8-2
Health Word	8-2
Health Store	8-2
Power Board LED Trip Information (Frame 4 and 5)	8-3

Manage Trips from the Keypad	8-4
Trip Messages	8-4
Symbolic Alarm Messages	8-5
Self Test Alarms	8-6
Setting Trip Conditions	8-6
Viewing Trip Conditions	8-6
Inhibiting Alarms	8-6
Test Points	8-7
Maintenance	8-7
Repair	8-7
Section 9	
Specifications & Product Data	9-1
Specifications	9-1
Keypad Display	9-2
Control Specifications	9-2
Encoder	9-3
Tachometer	9-3
Terminal Tightening Torque	9-3
Ratings	9-3
Dimensions	9-4
EMC Filters	9-5
Appendix A	
CE Guidelines	A-1
CE Declaration of Conformity	A-1
EMC – Conformity and CE – Marking	A-1
EMC Installation Instructions	A-3
Appendix B	
Parameter Table	B-1
Parameter Values	B-1
Parameters Listed by Tag Number	B-1
Parameters Listed by Name	B-10
Parameters Listed by Keypad Menu	B-19
Parameters Listed by WB Block	B-28
Appendix C	
Block Diagram	C-1

Section 1 Quick Start

The basic steps for connection and setup are provided in this section. Detailed descriptions of each step and parameter settings are provided later in this manual. Be sure to comply with all applicable codes when installing this control. The Series 29 DC control is a one way control. That is, it is non-regen and cannot reverse direction. It operates in the forward direction only. All references to reverse operation or regen operation apply to the Series 30 DC Control only.

Minimum Connection Requirements

Refer to Section 4 for cover removal procedure.

Power and Motor Connections

Figure 1-1 shows the minimum connections required at the power connector.

Figure 1-1 Power Connections

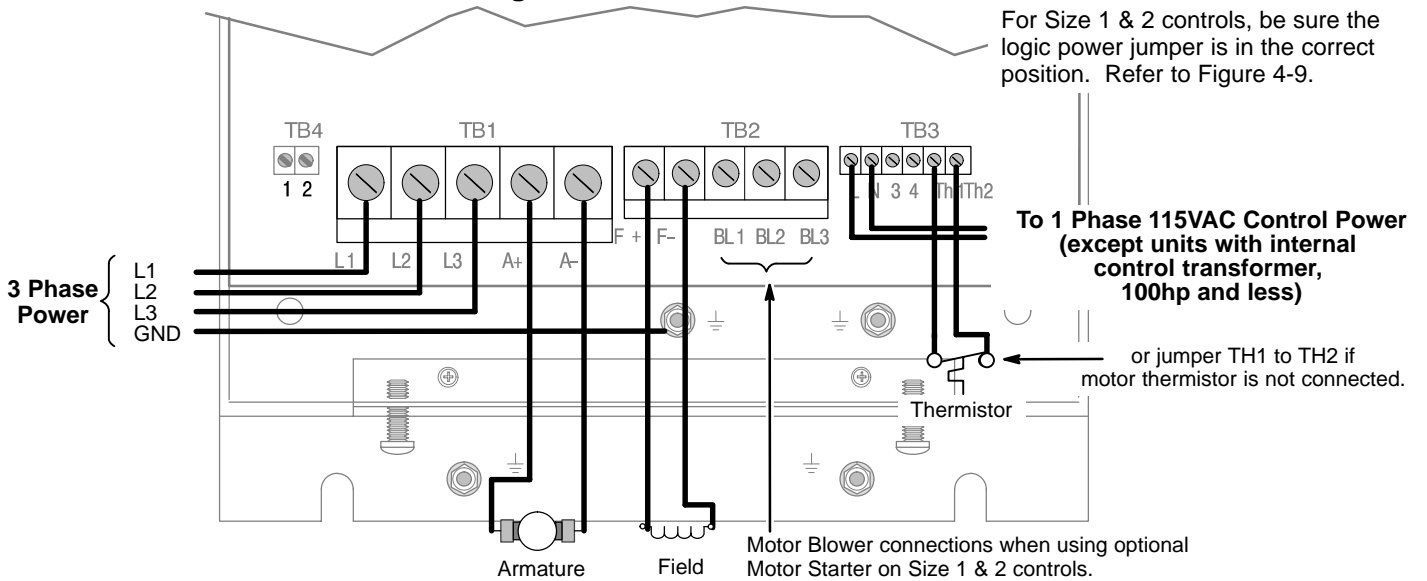

Reference and Jumpers for Keypad Operation

For keypad operation, the speed reference connections are not required. Speed is set at the keypad. Figure 1-2 shows the minimum connections required A, B and C signal connectors for Keypad operation.

Figure 1-2 Reference and Jumper Connections

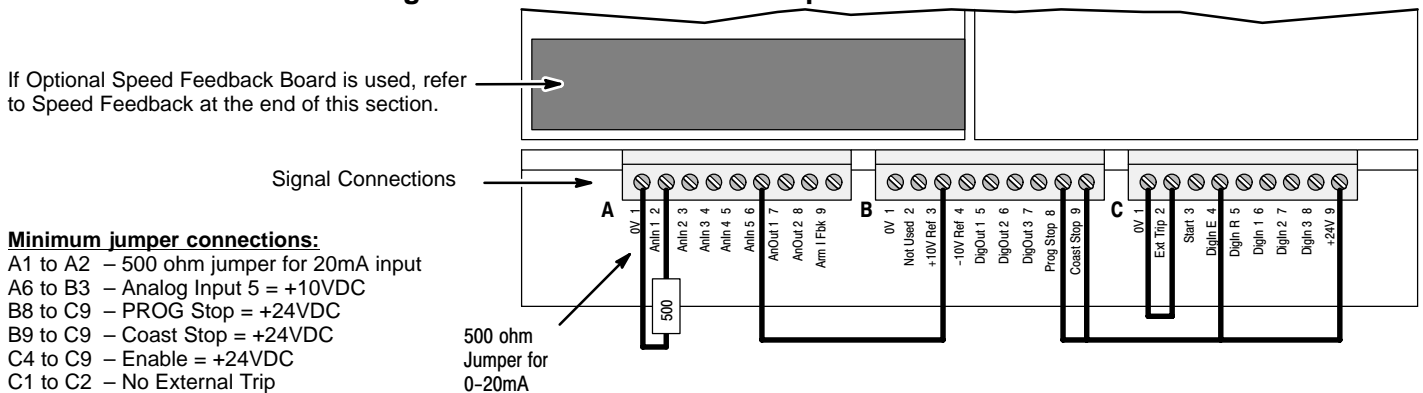

Parameter Settings (for Keypad Operation)

The factory settings should be sufficient to operate the control using the “Local” mode with the keypad. Only a few changes to the motor data parameters must be made. Before any parameters can be changed, set System::Configure I/O::Configure Enable to enable. All LEDs will blink during configuration.

Note: To separate the various menu level designation, a double colon is used (System::Configure I/O).

Reference and Jumpers for Remote Operation

For remote operation, the speed reference and other connections are made at the terminal strip connector. Not all of these connections are shown in Figure 1-3.

Figure 1-3 Reference and Jumper Connections

Speed Reference connections:

- A1 – one end of Pot
- B3 – one end of Pot
- A4 – wiper of Pot
- C1 to C2 – No External Trip

Minimum jumper connections:

- A1 to A2 – 500 ohm jumper for 20mA input
- A6 to B3 – Analog Input 5 = +10VDC
- C4 to C9 – Enable = +24VDC
- C1 to C2 – No External Trip

- Jumper if contacts are not used:
- B8 to C9 – PROG Stop = +24VDC
 - B9 to C9 – Coast Stop = +24VDC

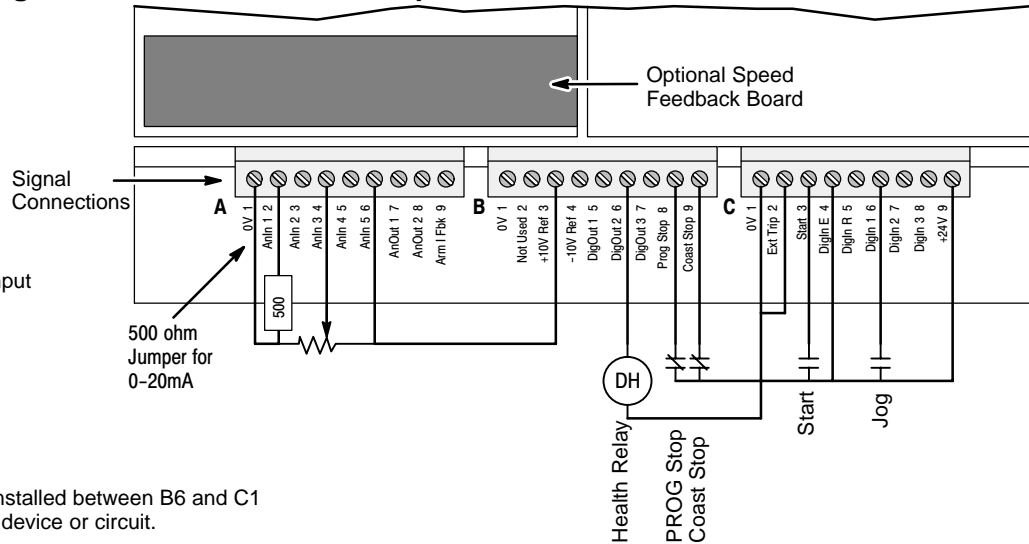

The Health relay (24VDC coil) may be installed between B6 and C1 to provide fault indication to an external device or circuit.

Speed Feedback The factory setting for speed feedback is Armature Voltage which does not require an optional feedback board. If an optional board must be used, refer to its manual to install and set the board configuration.

Serial Link A PC COM port may be connected to the control at the System Port (P3). At Menu Level : Serial Links, all of the parameters can be set for your application.

▲ and ▼ scroll the menu choices, and “M” goes to next level menu and “E” comes back up one menu level.

Action	Description	Display	Comments
Apply Power	Keypad Display shows this opening message.	FORWARD REF: 0.00%	Local control display.
Press “PROG” key		BALDOR DC DRIVE DC 4Q 15A	This message may be different for each control size.
Press “M” key	Access the menus.	DC 4Q 15A MENU LEVEL	
Press “M” key		MENU LEVEL DIAGNOSTICS	
Press ▲	Scroll to “Configure Drive” menu.	MENU LEVEL CONFIGURE DRIVE	
Press “M” key	Access the Configure Drive Menu	CONFIGURE DRIVE CONFIGURE ENABLE	Press M twice to go down 2 menu levels
Press “M” key	Access Configure Enable.	CONFIGURE ENABLE DISABLED	Configure enable is disabled and no parameter value can be changed.
Press ▲ key	Change Disabled to Enabled.	CONFIGURE ENABLE ENABLED	Configure enable must be enabled to allow a change to any parameter value. All LED’s on keypad are blinking to show it is enabled.
Press “E” key	Return to the Configure Drive Menu	CONFIGURE DRIVE CONFIGURE ENABLE	
Press ▼	Set the motor volts.	NOM MOTOR VOLTS	Use up and down arrows to set the motor voltage.
Press ▼	Set the armature current.	ARMATURE CURRENT	Use up and down arrows to set. Press “E” when done.
Press ▼	Set the field current (skip if field is in voltage mode).	FIELD CURRENT	Use up and down arrows to set. Press “E” when done.
Press ▼	Set the field control mode (voltage or current).	FLD. CTRL MODE	Use up and down arrows to set. Press “E” when done.
Press ▼	Field Volts Ratio= (field volts/AC supply)*100	FLD. VOLTS RATIO	Use up and down arrows to set. Press “E” when done.
Press ▼	Set the current limit (normally 100%).	MAIN CURR. LIMIT	Use up and down arrows to set. Press “E” when done.
Press ▼	Leave autotune off.	AUTOTUNE	Autotune after calibration is complete.
Press ▼	Select Armature Volts, Analog TACH or Encoder.	SPEED FBK SELECT	Use up and down arrows to set. Press “E” when done.
Press ▼	Set the pulses per REV of the encoder.	ENCODER LINES	Use up and down arrows to set. Press “E” when done.
Press ▼	Set the encoder max speed (100% speed).	ENCODER RPM	Use up and down arrows to set. Press “E” when done.
Press ▼	Change the polarity of the encoder signal if needed.	ENCODER SIGN	Use up and down arrows to set. Press “E” when done.
Press ▼	The Speed Loop Integral Gain.	SPD INT TIME	Use up and down arrows to set. Press “E” when done.
Press ▼	The Speed Loop Proportional Gain.	SPEED PROP GAIN	Use up and down arrows to set. Press “E” when done.

Configure the drive parameters and block diagram connections.

Action	Description	Display	Comments
Press "M" key		DC 4Q 15A MENU LEVEL	
Press "M" key	Access the menus.	MENU LEVEL DIAGNOSTICS	
Press ▲ or ▼	Scroll to "Configure Drive" menu.	MENU LEVEL SETUP PARAMETERS	Press "E" when done.

Setup Parameters

At Menu Level : Setup Parameters, several sub menus set values for your application:

Ramps, AUX I/O, Op Station, Jog/Slack, Raise/Lower, Special Blocks, Field Control, Current Profile, Inverse Time, Stop Rates, Calibration, Inhibit Alarms, Current Loop, Speed Loop, Standstill and Setpoint Sum 1.

Password

At Menu Level : Password, a password can be set to prevent unauthorized access to the setup and other parameters.

Configure I/O

At Menu Level : System : Configure I/O, make the connections using the Tags to configure the block diagram to your application.

Autotune

At Menu Level : Configure Drive, set Autotune to On, press "E" to exit configure menu. At the keypad, press L/R for local mode. Press Run, the drive will autotune. When the drive stops and no error messages are displayed, autotune was successful. Repeat the Save Parameters procedure to ensure the new values are saved.

When completed, change the Configure Enable parameter from Enabled to Disabled.

Action	Description	Display	Comments
Press ▲ or ▼	Scroll to "Configure Drive" menu.	MENU LEVEL CONFIGURE DRIVE	
Press "M" key	Access the Configure Drive Menu	CONFIGURE DRIVE CONFIGURE ENABLE	Press M twice to go down 2 menu levels
Press "M" key	Access Configure Enable.	CONFIGURE ENABLE ENABLED	Configure enable is disabled and no parameter value can be changed.
Press ▲ key	Change Disabled to Enabled.	CONFIGURE ENABLE DISABLED	Configure enable must be enabled to allow a change to any parameter value. All LED's on keypad are blinking to show it is enabled.
Press "E" key 2 times	Return to the Menu Level.	MENU LEVEL CONFIGURE DRIVE	

Save Parameters

At Menu Level : Save Parameters, save the settings you have programmed into the control. This will be the parameters that are restored for use after power up. If you do not save the parameters, the factory settings (or the last saved) will be used after a power up.

Action	Description	Display	Comments
Start at Menu Level 1		MENU LEVEL DIAGNOSTICS	
Press ▼	Scroll to "PARAMETER SAVE" menu.	MENU LEVEL PARAMETER SAVE	
Press "M" key		PARAMETER SAVE UP TO ACTION	
Press ▲	Press ▲ to save parameters.	PARAMETER SAVE REQUESTED	Parameters are saved. Except the "Local Setpoint".
Press "E" key	Exit one level	MENU LEVEL PARAMETER SAVE	Press "E" several times to return to the top level.

Section 2 General Information

Copyright Baldor © 2002. All rights reserved.

This manual is copyrighted and all rights are reserved. This document may not, in whole or in part, be copied or reproduced in any form without the prior written consent of Baldor.

Baldor makes no representations or warranties with respect to the contents hereof and specifically disclaims any implied warranties of fitness for any particular purpose. The information in this document is subject to change without notice. Baldor assumes no responsibility for any errors that may appear in this document.

Microsoft and MS-DOS are registered trademarks, and Windows is a trademark of Microsoft Corporation. UL and cUL are registered trademarks of Underwriters Laboratories.

Overview

The Series 29 DC control is a one way control. That is, it is non-regen and cannot reverse direction. It operates in the forward direction only. All references to reverse operation or regen operation apply to the Series 30 DC Control only. The Baldor Digital DC control is a three phase, full wave, DC motor armature and field control. The SCR bridge converts three phase AC power to controlled DC to operate the DC motor armature. The AC input is also used for the reference transformer input to operate power supplies and synchronize to the AC input line. This control is of the NEMA Type C designation.

The control may also be used with permanent magnet field motors and DC spindle drive motors. In addition, standard feedback from armature may be used. An optional Encoder, Tachometer or resolver feedback is available with optional expansion boards. The control can be configured to operate in a number of modes depending upon the application requirements and user preference.

It is the responsibility of the user to determine the correct operating mode to use for the application. These choices are made using the keypad as explained in this manual.

CE Compliance

A custom unit may be required, contact Baldor. Compliance to Directive 89/336/EEC is the responsibility of the system integrator. A control, motor and all system components must have proper shielding, grounding, and filtering as described in MN1383. Please refer to MN1383 for installation techniques for CE compliance. For additional information, refer to Section 4 and Appendix A of this manual.

Enclosure Sizes

Five enclosure sizes are available:

Size 1	15A to 35A
Size 2	40A to 165A
Size 3	180A to 270A
Size 4	380A to 830A
Size 5	850A and larger

Limited Warranty

For a period of one (1) year from the date of original purchase, BALDOR will repair or replace without charge controls and accessories which our examination proves to be defective in material or workmanship. This warranty is valid if the unit has not been tampered with by unauthorized persons, misused, abused, or improperly installed and has been used in accordance with the instructions and/or ratings supplied. This warranty is in lieu of any other warranty or guarantee expressed or implied. BALDOR shall not be held responsible for any expense (including installation and removal), inconvenience, or consequential damage, including injury to any person or property caused by items of our manufacture or sale. (Some states do not allow exclusion or limitation of incidental or consequential damages, so the above exclusion may not apply.) In any event, BALDOR's total liability, under all circumstances, shall not exceed the full purchase price of the control. Claims for purchase price refunds, repairs, or replacements must be referred to BALDOR with all pertinent data as to the defect, the date purchased, the task performed by the control, and the problem encountered. No liability is assumed for expendable items such as fuses.

Goods may be returned only with written notification including a BALDOR Return Authorization Number and any return shipments must be prepaid.

Product Notice

Intended use:

These drives are intended for use in stationary ground based applications in industrial power installations according to the standards EN60204 and VDE0160. They are designed for machine applications that require variable speed controlled three phase brushless AC motors.

These drives are not intended for use in applications such as:

- Home appliances
- Mobile vehicles
- Ships
- Airplanes

Unless otherwise specified, this drive is intended for installation in a suitable enclosure. The enclosure must protect the control from exposure to excessive or corrosive moisture, dust and dirt or abnormal ambient temperatures.

In the event that a control fails to operate correctly, contact Baldor for return instructions.

Safety Notice:

This equipment contains high voltages. Electrical shock can cause serious or fatal injury. Only qualified personnel should attempt the start-up procedure or troubleshoot this equipment.

This equipment may be connected to other machines that have rotating parts or parts that are driven by this equipment. Improper use can cause serious or fatal injury. Only qualified personnel should attempt the start-up procedure or troubleshoot this equipment.

- System documentation must be available at all times.
- Keep non-qualified personnel at a safe distance from this equipment.
- Only qualified personnel familiar with the safe installation, operation and maintenance of this device should attempt start-up or operating procedures.
- Always remove power before making or removing any connections to this control.

PRECAUTIONS: Classifications of cautionary statements.

 **WARNING:** Indicates a potentially hazardous situation which, if not avoided, could result in injury or death.

 **Caution:** Indicates a potentially hazardous situation which, if not avoided, could result in damage to property.

Continued on next page.

PRECAUTIONS:

- ⚠ WARNING:** Do not touch any circuit board, power device or electrical connection before you first ensure that power has been disconnected and there is no high voltage present from this equipment or other equipment to which it is connected. Electrical shock can cause serious or fatal injury.
- ⚠ WARNING:** Be sure that you are completely familiar with the safe operation of this equipment. This equipment may be connected to other machines that have rotating parts or parts that are controlled by this equipment. Improper use can cause serious or fatal injury.
- ⚠ WARNING:** Be sure all wiring complies with the National Electrical Code and all regional and local codes or CE Compliance. Improper wiring may cause a hazardous condition.
- ⚠ WARNING:** Be sure the system is properly grounded before applying power. Do not apply AC power before you ensure that grounds are connected. Electrical shock can cause serious or fatal injury.
- ⚠ WARNING:** Do not remove cover for at least five (5) minutes after AC power is disconnected to allow capacitors to discharge. Electrical shock can cause serious or fatal injury.
- ⚠ WARNING:** Improper operation may cause violent motion of the motor and driven equipment. Be certain that unexpected movement will not cause injury to personnel or damage to equipment.
- ⚠ WARNING:** Motor circuit may have high voltage present whenever AC power is applied, even when motor is not moving. Electrical shock can cause serious or fatal injury.
- ⚠ WARNING:** If a motor is driven mechanically, it may generate hazardous voltages that are conducted to its power input terminals. The enclosure must be grounded to prevent a possible shock hazard.
- ⚠ WARNING:** The user must provide an external hard-wired emergency stop circuit to disable the control in the event of an emergency.

Continued on next page.

-
- ⚠ Caution:** To prevent equipment damage, be certain that the input power has correctly sized protective devices installed as well as a power disconnect.
- ⚠ Caution:** Avoid locating the control immediately above or beside heat generating equipment, or directly below water or steam pipes.
- ⚠ Caution:** Avoid locating the control in the vicinity of corrosive substances or vapors, metal particles and dust.
- ⚠ Caution:** Suitable for use on a circuit capable of delivering not more than the RMS symmetrical short circuit amperes listed here at rated voltage.
- | <u>Horsepower</u> | <u>RMS Symmetrical Amperes</u> |
|-------------------|--------------------------------|
| 1.5–50 | 5,000 |
| 51–200 | 10,000 |
| 201–400 | 18,000 |
| 401–600 | 30,000 |
| 601–900 | 42,000 |
- ⚠ Caution:** Baldor recommends not using “Grounded Leg Delta” transformer power leads that may create ground loops and degrade system performance. Instead, we recommend using a four wire Wye.
- ⚠ Caution:** Logic signals are interruptible signals; these signals are removed when power is removed from the drive.
- ⚠ Caution:** The safe integration of the drive into a machine system is the responsibility of the machine designer. Be sure to comply with the local safety requirements at the place where the machine is to be used. In Europe this is the Machinery Directive, the ElectroMagnetic Compatibility Directive and the Low Voltage Directive. In the United States this is the National Electrical code and local codes.
- ⚠ Caution:** Controls must be installed inside an electrical cabinet that provides environmental control and protection. Installation information for the drive is provided in this manual. Motors and controlling devices that connect to the driver should have specifications compatible to the drive.
- ⚠ Caution:** Do not tin (solder) exposed wires. Solder contracts over time and may cause loose connections.
- ⚠ Caution:** Electrical components can be damaged by static electricity. Use ESD (electro-static discharge) procedures when handling this control.
- ⚠ Caution:** This control is not designed for regenerative use with stabilized shunt or compound wound motors. If stabilized shunt or compound wound are to be used, the series field must be isolated and not connected. Contact the motor manufacturer for motor derating specifications under these conditions.

Section 3 Getting Started

Control Overview

Control Loops

In very simple terms, control of the DC motor is maintained by Control Loops. An inner Current Loop and an outer Speed Loop are used. These control loops are shown in the Block Diagram of Appendix C. From the keypad, you can select the control loops to be used by the Control to provide either:

- Current Control
- Speed Control (factory setting)

Normally a current or speed feedback signal is applied to the appropriate loop to control the process. While current feedback sensors are built-in, speed feedback is normally provided directly from the armature sensing circuit (default), or by “Tachogenerator” or encoder connection to an option board.

Figure 3-1 Speed Control

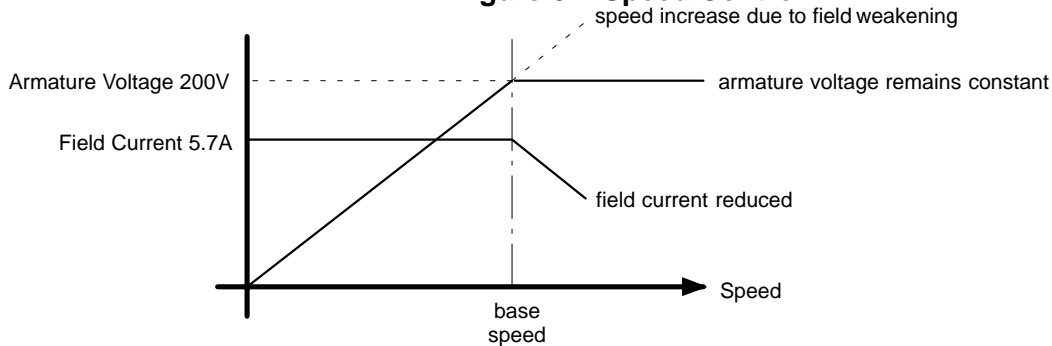

During speed control the speed of the motor can be increased by adjusting the motor field. Weakening the field current allows an increase in motor speed beyond that normally achieved for the motor rated armature voltage.

Control and Communications

Some of the internal blocks of this control must be connected for your application. This means that you must understand the application and how the software blocks should be connected to implement your design. The block diagram in Appendix C shows the factory set connections. These diagrams assist in understanding this concept and will be described next.

The Keypad (Operator Station) provides access to parameters, diagnostic messages, trip settings and full application programming. The heart of the control is a microprocessor that provides advanced features such as:

- Complex control algorithms not achievable by simple analog techniques.
- Software configured control circuitry that uses standard software blocks.
- Serial link communications with other drives or a PC for advanced process systems.

To customize drive performance for optimum use, you may need to configure, or reroute software connections to and from the drive's inputs and outputs and to and from the drive's software blocks. You can configure the drive and change software block parameter values either using the keypad or with a personal computer (PC) running the software package Workbench D (see MN794).

Local and Remote Modes

Determine what operating mode is best for your application. Four modes are possible, see Figure 3-2.

Figure 3-2 Local and Remote Modes

Local: Keypad Setting (Factory Setting)

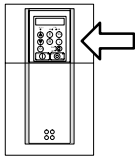

For local operation, use the keypad to change parameters or control operation.

Remote: Terminal Strip Setting

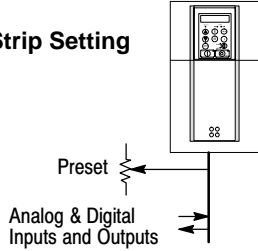

Process control and other applications may require the control to be used in remote mode with analog and digital input/output signals performing all control operations. The control is configured in this mode from the factory.

Remote: Serial Setting

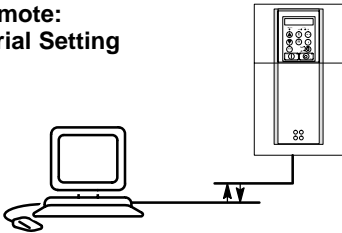

Remote Serial mode is used to initially setup and configure the parameters of the control. For applications that are controlled by a PC that is running suitable software. Workbench D is recommended.

Remote: COMMS Setting

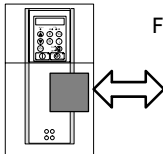

For Baldor RS485/Modbus, Profibus DP and DeviceNet.

Two forms of control are in operation at all times: Start/Stop Control and Speed Control. These are operate by local or remote control.

Local

The keypad is used to set motor speed and other parameters. The Start, Stop and Jog keys then control motor rotation.

Remote

A speed reference signal (pot) and the various analog and digital inputs and outputs are used for speed control and rotation of the motor shaft.

Source / Destination Tags

The control is very flexible because of the programming capability. The software block diagram of the control is shown in Appendix C. Each logic block has inputs and outputs. These I/O points are called “Tags” because they have a tag number associated with it and shown in brackets “[tag]”. Some tags are read only values and some are read/write. Besides setting the value of each parameter, its source or destination connections can be programmed. This means you can connect inputs and outputs of logic blocks as you desire to implement your application.

Destination Tag example

Consider Digital Input 1. The external connection (input) is made at the C connector pin 6. The block diagram of this input is shown in Figure 3-3. Tag [102] is the destination tag for the output signal. The destination is presently set to 90. This connects the output of Digital Input 1 to the Bipolar Clamps [90] input of the Current Loop Logic Block. The value of [102] Digital output is determined by the switch position, either the value of [103] or [104] will be applied to the output as the input changes from false to true.

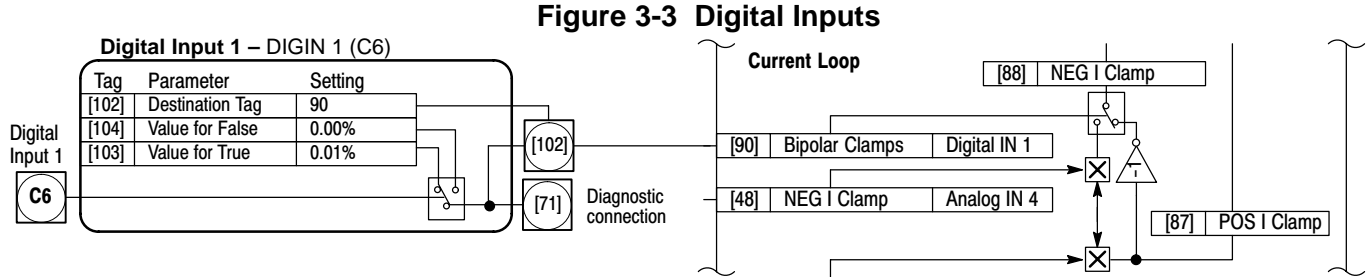

Source Tag example

Consider Digital Output 1. The external connection (output) is made at the B connector pin 5. The block diagram of this input is shown in Figure 3-4. Tag [97] is the source tag for the input signal. The source is presently set to 77. This means that Digital output 1 receives its input signal from [77] At Zero Speed parameter from the Standstill Logic Block. To connect Digital Output 1 to the At Zero Setpoint parameter, simply change [97] Source Tag value from 77 to 78.

Figure 3-4 Digital Outputs

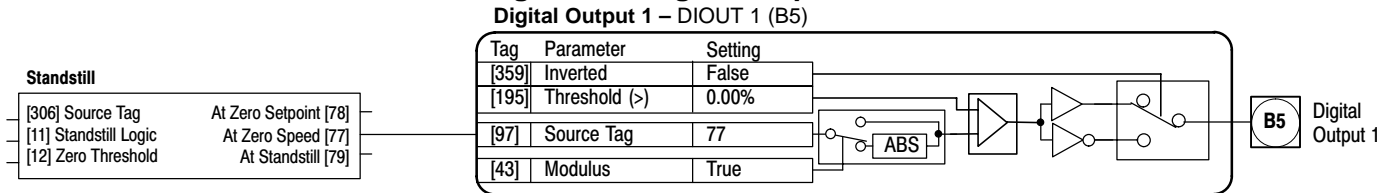

From these examples, it is easy to see that several things are required to program the control.

1. First, you must understand the application and know how to implement it in the control parameters.
2. Second, layout all of the connections for your application using the block diagrams in Appendix C.
3. Third, program the connections and parameter preset values. To do this you will need to refer to the Parameter Values in Appendix B. This will tell you where in the keypad menu system you can locate each parameter value or [tag].

For example, find [97] in Appendix B, (see Figure 3-5). To locate [97] using the keypad, begin at the System menu, select Configure I/O menu, then select Digital Outputs menu, finally select Digital Output 1 (B5) parameter. Change the value of that parameter to the desired value.

Note: Tag number “[97]” is not shown at the keypad for the Digital Output 1 (B5) parameter value. To display the [TAG] number of the parameter, display the parameter value then press the “M” key to show the parameters tag number. Appendix B and C are the key to programming your application.

Figure 3-5

Table B-1 Parameters Listed by Tag Number Continued

Tag	R/W	Name	Keypad Menu	WB Block	Range	Factory Setting	MN	Notes
97	RW	Source Tag	SYSTEM::CONFIGURE I/O::DIGITAL OUTPUTS::DIGOUT 1 (B5)	Digout 1 (B5)	0 to 549	77	cp	2, 3

4. Select the next parameter and repeat step 3.

Programming Block A very important step to installing this control is to determine the configuration that will best implement your application. Each input and output of each block has an assigned tag number. Tags are connected in software much like jumper wires are used in hardware. The control is shipped with a factory set software connection. This may be changed at any time. The method of changing these connections (source or destination tags) is described later in the programming Section 6 of this manual.

Note: It is important to correctly set the software to implement your application in the most efficient way. Some parameters are Tags (connections) and others are programmed values. Be careful when programming to be sure the correct input or output is being set.

Example (View Analog Input 1 parameter settings)

As an example, a portion of the block diagram is shown in Figure 3-6. The output of Analog Input 1 [246] is connected to [100] "Input 1" of Setpoint Sum 1 block. Each input and output shown on these diagrams is programmable.

Figure 3-6 Analog Input Example

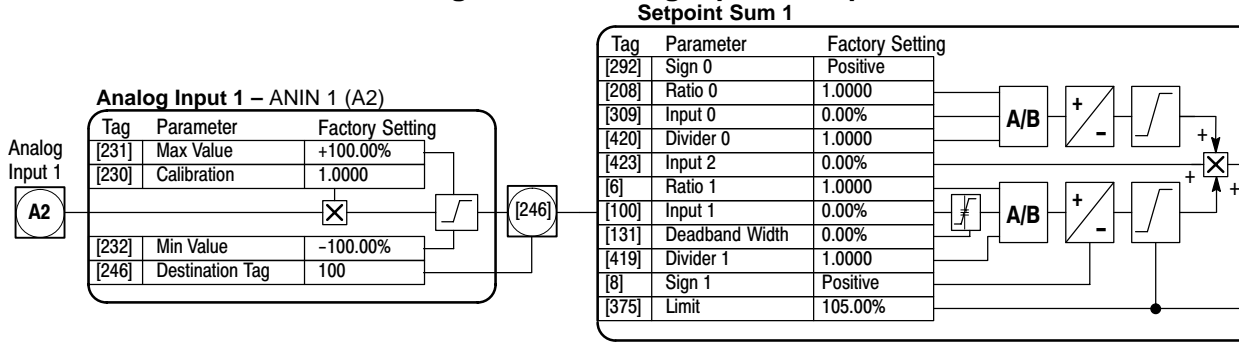

The parameter values for Analog Input 1 can be changed at the keypad. Figure 3-7 shows a partial map of the menu levels. The Analog Input 1 parameters are at Level 4 under the Level 3 Analog Inputs. The keypad operation is shown in Table 3-1. Figure 3-7 can be used to visualize the menu structure that is being navigated in Table 3-1.

Figure 3-7

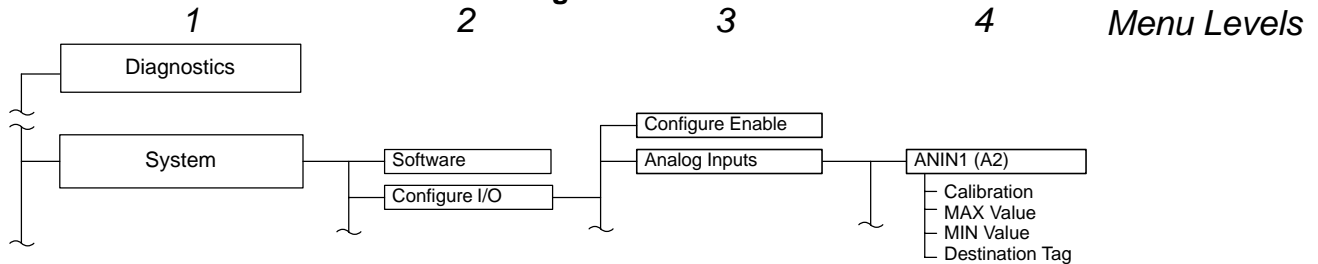

Table 3-1 Set Analog Input 1 for 4–20mA

Action	Description	Display	Comments
Apply Power	Keypad Display shows this opening message.	FORWARD REF: 0.00%	This message may be different for each control.
Press "PROG" key		BALDOR DC DRIVE DC 4Q 35A	
Press M	Access the menus.	MENU LEVEL DIAGNOSTICS	This is menu level 1. Refer to Figure 3-7 for a description of the menu levels.
Press ▼	Scroll to System menu. Press ▼ several times.	MENU LEVEL SYSTEM	This is menu level 1, System parameters.
Press M	Access the System menus.	SYSTEM SOFTWARE	This is menu level 2.
Press ▼	Scroll to Configure I/O menu.	SYSTEM CONFIGURE I/O	
Press M	Access Configure I/O menu.	CONFIGURE I/O CONFIGURE ENABLE	

Table 3-1 Set Analog Input 1 for 4–20mA Continued

Action	Description	Display	Comments	
Press M	Access Configure I/O menu.	CONFIGURE ENABLE DISABLE	This is menu level 3. Before any parameter values can be changed, Configure Enable must be “Enabled” (it is normally disabled”).	
Press ▲	Change Configure Enable to Enabled.	CONFIGURE ENABLE ENABLED		
Press E	Access Configure I/O menu.	CONFIGURE I/O CONFIGURE ENABLE	Move back one menu level using the E key.	
Press ▼	Scroll to analog inputs menu.	CONFIGURE I/O ANALOG INPUTS		
Press M	Access analog inputs 1 menu.	ANALOG INPUTS ANIN1 (A2)	This is menu level 4.	
Press M	Access Calibration menu.	ANIN1 (A2) CALIBRATION		
Press M	View or change the Calibration value.	CALIBRATION 1.0000		
Press E		ANIN1 (A2) CALIBRATION		
Press ▼	Scroll to next menu.	ANIN1 (A2) MAX VALUE		
Press M	View or change the MAX Value menu.	MAX VALUE 100.00%		
Press E		ANIN1 (A2) MAX VALUE		
Press ▼	Scroll to next menu.	ANIN1 (A2) MIN VALUE		
Press M	View or change the MIN Value menu.	MIN VALUE -100.00%		
Press E		ANIN1 (A2) MIN VALUE		
Press ▼	Scroll to next menu.	ANIN1 (A2) DESTINATION TAG	Use the ▲ and ▼ keys to change the value. Press E when finished.	
Press M	View or change the Destination tag Value menu.	DESTINATION TAG 100		
Press E	Press “E” several times to return to the Configure Enable menu.	ANIN1 (A2) DESTINATION TAG	This is menu level 2.	
Press M	Access Configure I/O menu.	CONFIGURE I/O CONFIGURE ENABLE		
Press M	Access Configure I/O menu.	CONFIGURE ENABLE ENABLED		
Press ▼	Change Configure Enable to Disabled.	CONFIGURE ENABLE DISABLED		
Press E		CONFIGURE I/O CONFIGURE ENABLE		
				This is menu level 3. Before the control can be used again, Configure Enable must be “Disabled”.
				Note when ▼ is pressed, the keypad will briefly display “calibrating” followed by Disabled and all Keypad LED’s stop blinking.

Press the “E” key several times to move back through the menu items or press “PROG” to return to control operation.

Note: When changing a numeric value, pressing the “M” key will change the cursor position one digit to the left.

Section 4 Receiving and Installation

Receiving & Inspection

Baldor Controls are thoroughly tested at the factory and carefully packaged for shipment. When you receive your control, there are several things you should do immediately.

1. Observe the condition of the shipping container and report any damage immediately to the commercial carrier that delivered your control.
2. Remove the control from the shipping container and remove all packing materials. The container and packing materials may be retained for future shipment.
3. Verify that the part number of the control you received is the same as the part number listed on your purchase order.
4. Inspect the control for external physical damage that may have been sustained during shipment and report any damage immediately to the commercial carrier that delivered your control.
5. If the control is to be stored before use, be sure that it is stored in a location that conforms to published storage humidity and temperature specifications stated in this manual.

Location Considerations The location of the control is important. Installation should be in an area that is protected from direct sunlight, corrosives, harmful gases or liquids, dust, metallic particles, and vibration. Exposure to these can reduce the operating life and degrade performance of the control.

Several other factors should be carefully evaluated when selecting a location for installation:

1. For effective cooling and maintenance, the control should be mounted vertically on a smooth non-flammable surface.
2. At least 1.0 inches (25mm) top and bottom clearance must be provided for air flow. At least 0.4 inches (10mm) clearance is required between controls (each side).
3. **Operating Altitude derating.** Up to 1640 feet (500 meters) no derating required. Derate the continuous and peak output current by 1% for each 660 feet (200 meters) above 1640 feet. Maximum operating altitude 16,500 feet (5,000 meters).
4. **Operating Temperature derating.** 0°C to 45°C (Sizes 1, 2); 0°C to 40°C (Sizes 3,4,5) ambient. Above rated temperature, derate the continuous and peak output current by 2% per °C above rating. Maximum ambient is 55°C.

Table 4-1 Watts Loss Ratings

Catalog No.	Output Current (A)	Watts Loss (W)	Catalog No.	Output Current (A)	Watts Loss (W)
BC29D7A35-CL7	35	117	BC29D7A380-CL1/CL2	380	1230
BC29D7A70-CL7	70	234	BC29D7A500-CL1/CL2	500	1590
BC29D7A110-CL7	110	354	BC29D7A725-CL1/CL2	725	2265
BC29D7A165-CL7	165	519	BC29D7A830-CL1/CL2	830	2580
BC29D7A243-CL1/CL2	243	840	BC29D7A1580-CL1/CL2	1580	4890

Cover Removal

To connect power and signal wires, the cover must be removed. This procedure describes how to access all terminal connections inside the control.

1. Loosen the two cover screws shown in Figure 4-8, then lift and remove the cover as shown.

Figure 4-1 Top Cover Removal

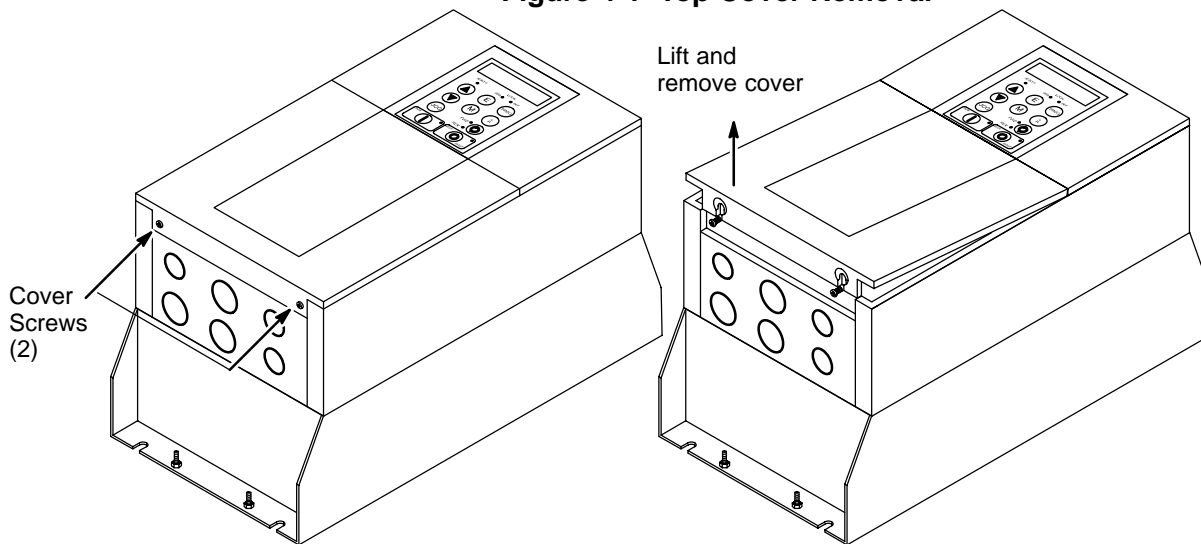

2. Locate the two 1/4 turn screws shown in Figure 4-2. Rotate each screw 1/4 turn CCW. This releases the control from the base.

Figure 4-2 Signal Connections

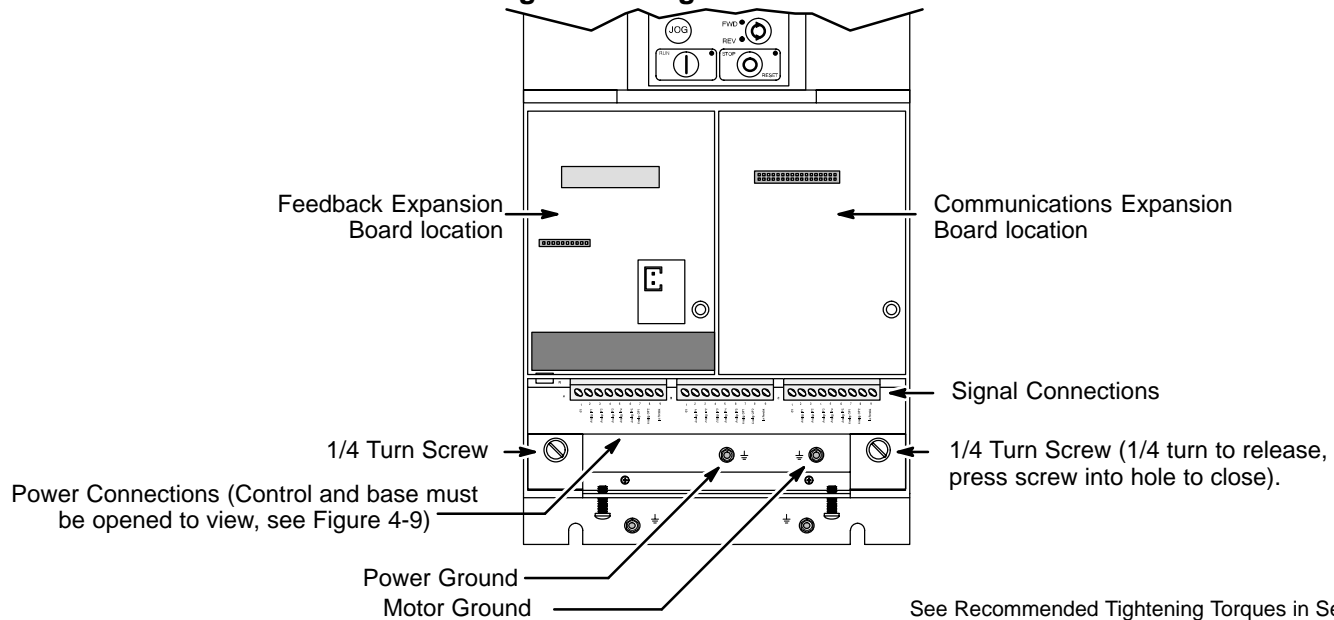

Cover Removal Continued

3. The control and base are hinged and are opened as shown in Figure 4-3.

Figure 4-3 Hinged Assembly

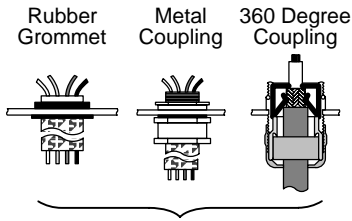

The knock-out panel is part of the base assembly to allow connections to be made. Use the correct size rubber grommet, conduit coupling or 360 degree coupling.

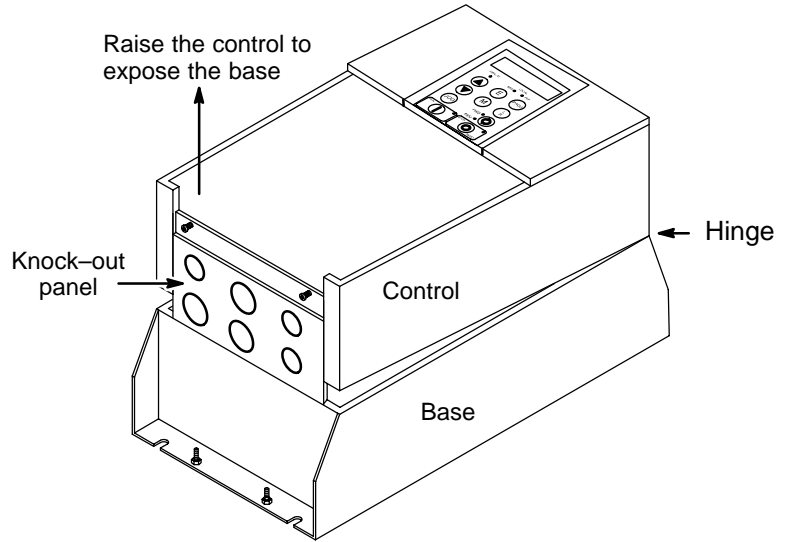
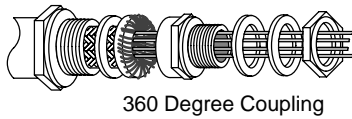

Mechanical Installation

Mount the control to the mounting surface. The control must be securely fastened to the mounting surface by the control mounting holes. The location of the mounting holes is shown in Section 9 of this manual.

External Vent Kit (Size 4 & 5 controls only)

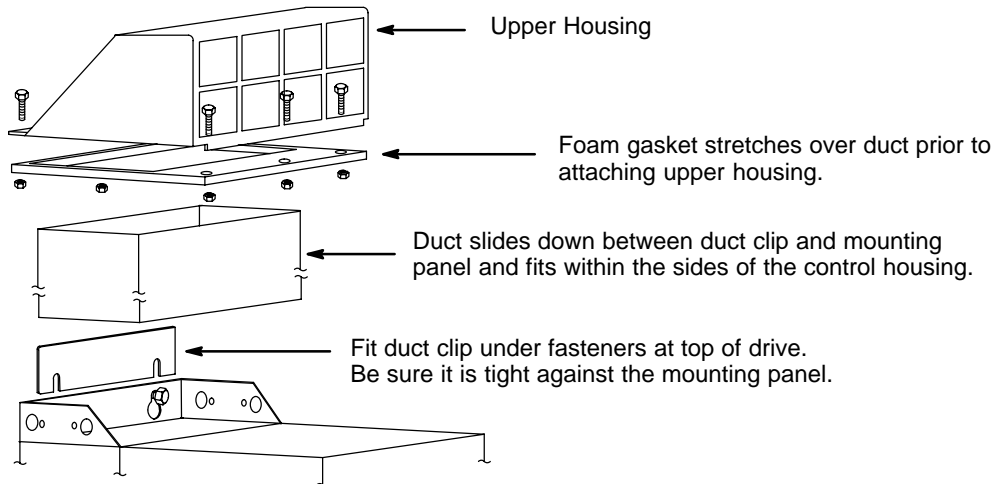

Optional Remote Keypad Installation (Enclosure rating of IP54 when correctly mounted). The keypad may be remotely mounted using optional Baldor keypad extension cable.

Tools Required:

- Center punch, file and screwdrivers (Phillips and straight) and crescent wrench.
- #19 drill and drill motor .

Figure 4-4 Remote Keypad Installation

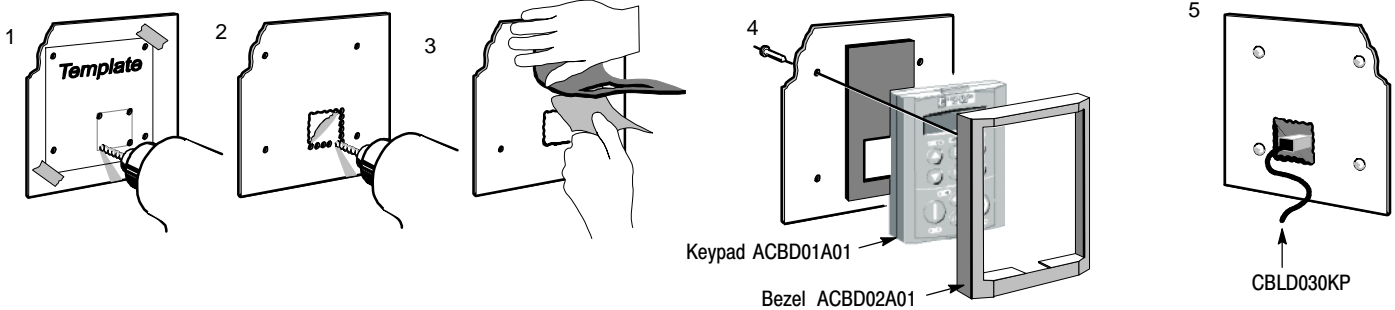

Mounting Instruction:

1. Locate a flat mounting surface. Place the template on the mounting surface (step 1).
2. Accurately center punch the mounting holes.
3. Drill holes for the two mounting screws.
4. Use the drill to remove metal for the 27 x 29 mm rectangular hole (step 2).
5. Deburr the rectangular hole making sure the panel stays clean and flat.
6. Remove the protective film from the keypad gasket (step 3).
7. Assemble the keypad to the panel. Use two screws provided (step 4).
8. Connect the 10 ft. cable at the keypad and P3 of the control (step 5).

Figure 4-5 Template

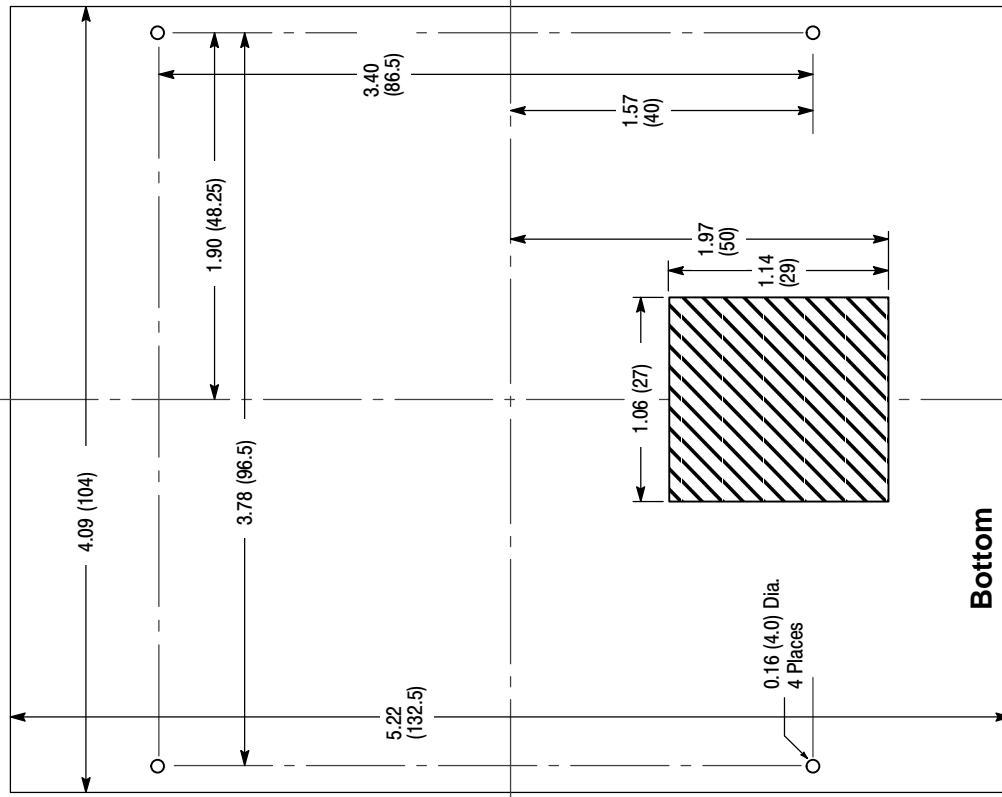

Electrical Installation All interconnection wires between the control, AC power source, motor, host control and any operator interface stations should be in metal conduits. Use listed closed loop connectors that are of appropriate size for wire gauge being used. Connectors are to be installed using crimp tool specified by the manufacturer of the connector. Only class 1 wiring should be used.

System Grounding Baldor controls are designed to be powered from standard single and three phase lines that are electrically symmetrical with respect to ground. System grounding is an important step in the overall installation. The recommended grounding method is shown in Figure 4-6.

Figure 4-6 Recommended System Grounding (3 phase) for UL

Note: Wiring shown for clarity of grounding method only. Not representative of actual terminal block location.

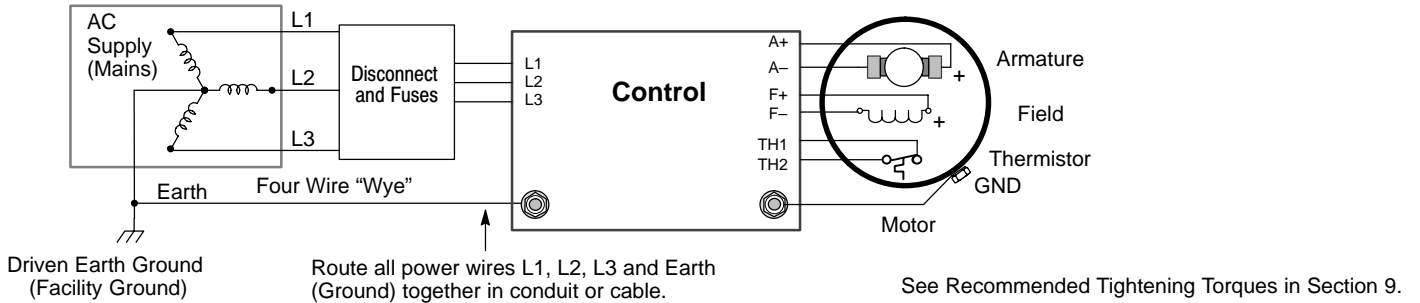

Ungrounded Distribution System

With an ungrounded power distribution system it is possible to have a continuous current path to ground through the MOV devices. To avoid equipment damage, an isolation transformer with a grounded secondary is recommended. This provides three phase AC power that is symmetrical with respect to ground.

Input Power Conditioning

Baldor controls are designed for direct connection to standard single and three phase lines that are electrically symmetrical with respect to ground. Certain power line conditions must be avoided. An AC line reactor or an isolation transformer may be required for some power conditions.

- If the feeder or branch circuit that provides power to the control has permanently connected power factor correction capacitors, an input AC line reactor or an isolation transformer must be connected between the power factor correction capacitors and the control.
- If the feeder or branch circuit that provides power to the control has power factor correction capacitors that are switched on line and off line, the capacitors must not be switched while the control is connected to the AC power line. If the capacitors are switched on line while the control is still connected to the AC power line, additional protection is required. TVSS (Transient Voltage Surge Suppressor) of the proper rating must be installed between the AC line reactor or an isolation transformer and the AC input to the control.

Line Impedance The control requires a 5% maximum line impedance (voltage drop across the reactor is 5% when the control draws rated input current). If the impedance of the incoming power does not meet the requirement for the control, a 3 phase line reactor can be used to provide the needed impedance in most cases. Line reactors are optional and are available from Baldor.

The input impedance of the power lines can be determined as follows:

Measure the line to line voltage at no load and at full rated load.

Use these measured values to calculate impedance as follows:

$$\% \text{Impedance} = \frac{(\text{Volts}_{\text{No Load Speed}} - \text{Volts}_{\text{Full Load Speed}})}{(\text{Volts}_{\text{No Load Speed}})} \times 100$$

Power Disconnect A power disconnect should be installed between each input power source and the control for a fail-safe method to disconnect power. The control will remain in a powered-up condition until all input power is removed from the control and the internal voltage is depleted.

Protection Devices The control must have a suitable input power protection device installed. Input and output wire size is based on the use of copper conductor wire rated at 75 °C. Table 4-3 describes the wire size to be used for power connections and Table 4-4 describes the ratings of the protection devices.

Recommended fuse sizes are based on the following:

UL 508C suggests a fuse size of four times the continuous output current of the control.

Dual element, time delay fuses should be used to avoid nuisance trips due to inrush current when power is first applied.

Electrical Installation Continued

Isolation Transformer Sizing

Use the information in Table 4-2 to select the KVA rating of the transformer based on the HP rating of the control. The secondary voltage will be the input voltage to the control and the impedance should be 2% or less.

One exception to Table 4-2 is when the DC armature voltage is less than the AC input voltage. If this is the case, use the following formula:

$$\text{KVA} = 0.00163 \times \text{VAC}_{\text{Secondary}} \times \text{IDC}_{\text{Secondary}}$$

Table 4-2 Isolation Transformer KVA Selection

HP	5	7.5	10	15	20	25	30	40	50	60	75	100	125	150	200	250	300
KVA	7.5	11	14	20	27	34	40	51	63	75	93	118	145	175	220	275	330

Single Phase Power Since the control rectifies all three input power phases, operation from a single phase power source is not possible.

Table 4-3 Wire Size

Catalog Number	Maximum Output **		Armature Current		Wire Size									
			Cont. (Amps)	Peak (Amps)	3 ϕ AC Input		Armature		Field Power Supply		Logic Power Supply		BL1,BL2,BL3	
	HP	kW			AWG	MM ²	AWG	MM ²	AWG	MM ²	AWG	MM ²	AWG	MM ²
BC29D7A35-CL7	20	15	35	53	8	8.37	8	8.37			14	2.08	12-22	3.31-0.326
BC29D7A70-CL7	40	30	70	105	4	21.2	3	26.7	14	2.08	14	2.08	6-18	13.3-0.823
BC29D7A110-CL7	60	50	110	165	1	42.4	1/0	53.5	14	2.08	14	2.08	6-18	13.3-0.823
BC29D7A165-CL7	100	75	165	248	3/0	85.0	4/0	107.0	14	2.08	14	2.08	6-18	13.3-0.823
BC29D7A243-CL1/CL2	150	120	243	365	300kcmil	152	350kcmil	177	14	2.08	14	2.08	6-18	13.3-0.823
BC29D7A380-CL1/CL2	200	150	380	570	700kcmil	355	750kcmil	380	8	8.37	14	2.08	6-18	13.3-0.823
BC29D7A500-CL1/CL2	300	225	500	750	1250kcmil	634	1500kcmil	760	8	8.37	14	2.08	6-18	13.3-0.823
BC29D7A725-CL1/CL2	400	327	725	1088	1"x3" BB*		1"x3" BB*		8	8.37	14	2.08	6-18	13.3-0.823
BC29D7A830-CL1/CL2	500	335	830	1245	1"x3" BB*		1"x4" BB*		8	8.37	14	2.08	6-18	13.3-0.823
BC29D7A1580-CL1/CL2	900	650	1580	2370	2"x4" BB*		2"x4" BB*		8	8.37	14	2.08	6-18	13.3-0.823

* BB is copper Bus Bar.

** Hp and kW are approximate at 500VDC Armature voltage.

Note: All wire sizes based on 75°C copper wire, 40°C ambient temperature, 4-6 conductors per conduit or raceway.

Table 4-4 Protection Devices

Catalog Number	Fuse Rating			
	3 ϕ AC Line (Ferraz-Shawmut)	Armature (Ferraz-Shawmut)	Field Supply (A)	Logic Supply (A)
BC29D7A35-CL7	A60Q40	A70QS50-14F	4	3
BC29D7A70-CL7	A50QS80-4R	A70QS80	10	3
BC29D7A110-CL7	A50QS125-4R	A70QS150	10	3
BC29D7A165-CL7	A50QS175-4R	A70QS200	10	3
BC29D7A243-CL1/CL2	A50QS300-4R	A70P350	10	3
BC29D7A380-CL1/CL2	A070URD32KI0400	A130URD73LI0450	30	3
BC29D7A500-CL1/CL2	A070URD32KI0630	A130URD73LI0700	30	3
BC29D7A725-CL1/CL2	A070URD32KI0800	A130URD73LI0900	30	3
BC29D7A830-CL1/CL2	A070URD32KI0900	14URD93TTF1250	30	3
BC29D7A1580-CL1/CL2	A070URD32KI0900 *	12.5URD94TDF2300M	30	3

* 6 fuses per drive.

Electrical Installation Continued

Figure 4-7 Size 1–5 Power Terminal Locations

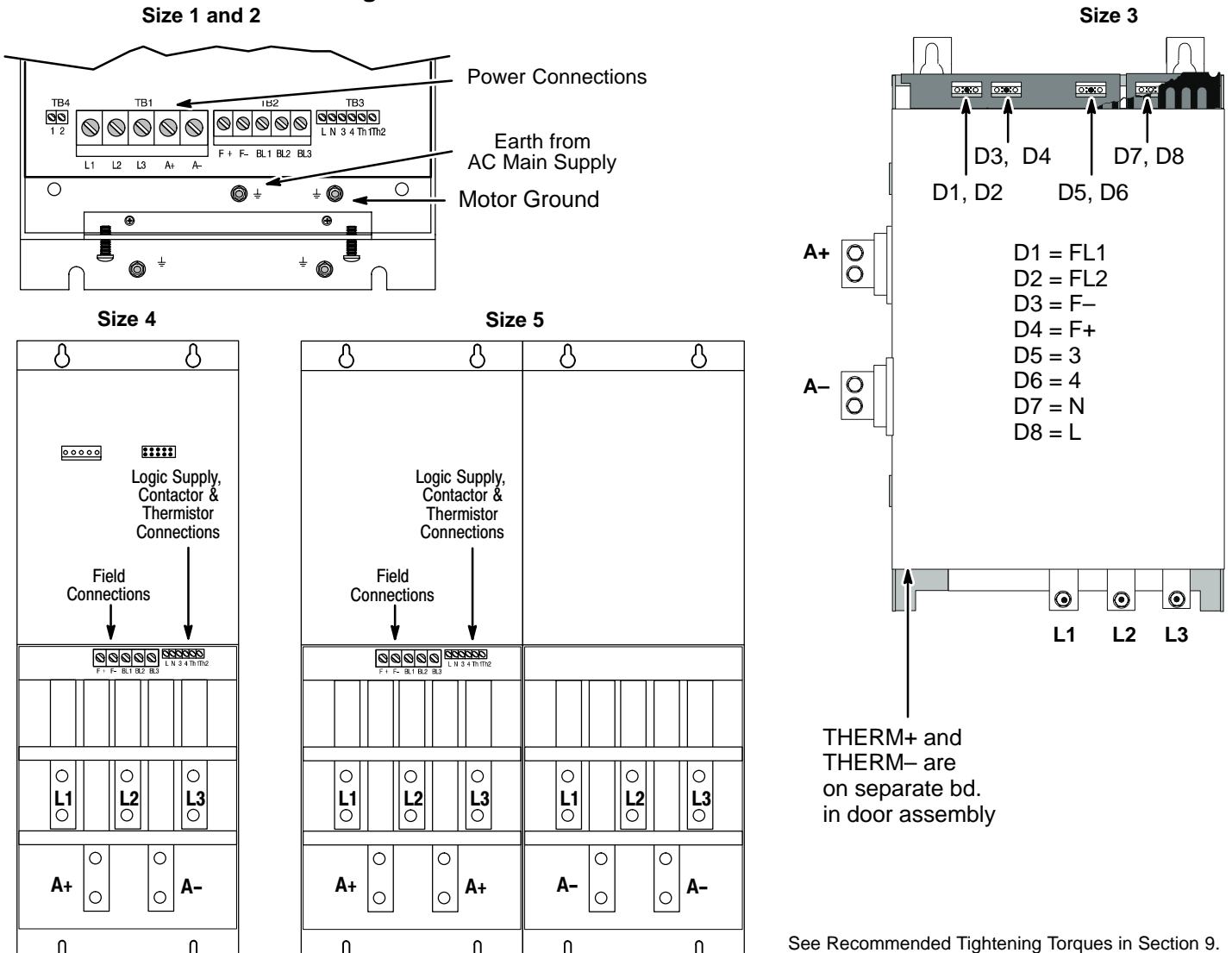

Table 4-5 Power Connector Signals

Terminal	Description
L1, L2, L3	Main AC input power. A 3-phase AC contactor should be connected in the main AC power supply connections. (AC Contactor is internal for Size 1 and 2 controls. For other sizes, use terminals 3 and 4).
A+, A-	The motor armature is connected to busbar terminals A+ and A-. If a DC contactor is used the contactor poles should be interposed between the control terminals and the motor terminals.
F+, F-	Connect the motor field (-) to terminal F- and field (+) to terminal F+. If the motor has no field connections, is a permanent magnet motor, or if the field is derived externally, you must disable the Field Enable [170] parameter.
FL1, FL2	An external field supply may be used for Size 2–5 controls. Connect this supply to terminals FL1 and FL2. The voltage is determined by the desired field voltage. The supply must be protected externally with suitable fuses. Always derive the supply from the Red and Yellow phases of the main power supply, with the Red phase connected to terminal FL1 and the Yellow phase connected to FL2.
3, 4	Size 3–5, the AC Contactor coil can be connected between TB3–3 (line) and TB3–4 (neutral) and its purpose is to provide AC power disconnection. Maximum coil inrush current must not exceed 3A.
L, N	Single phase AC power for logic circuits. The auxiliary supply must be connected directly to the incoming supply, (disconnect only). (Logic Supply is internal for Size 1 and 2 controls).
TH1, TH2	Connection for motor thermal protection. Thermistors must have a combined working resistance of 750 ohms or less, increasing to at least 4k ohms at over-temperature. The alarm is latched and the control must be restarted.

Electrical Installation Continued

Power Connections Single phase operation of this control is not possible.

Power connections are shown in Figure 4-8. (The location of these terminals is shown in Figure 4-9).

Figure 4-8 3 Phase Power Connections

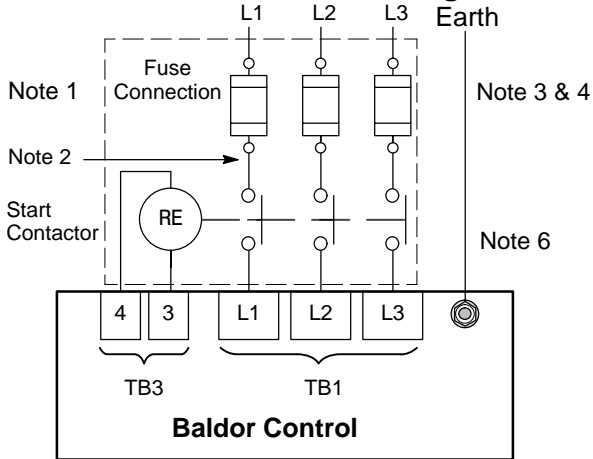

Notes:

1. See Protection Device description in this section.
2. Metal conduit or shielded cable should be used. Connect conduits so the use of a Reactor or RC Device does not interrupt EMI/RFI shielding.
3. Use the same gauge wire for Earth as used for L1, L2, L3 connections.
4. Use same gauge wire for Earth ground as is used for L and N, or L1, L2 L3. (VDE (Germany) requires 10mm² minimum, 6AWG).
5. Reference EMC wiring in Appendix A for CE compliance.
6. AC Contactor is internal for size 1 and 2 controls. Size 3-5, the contactor can be connected between TB3-3 (line) and TB3-4 (neutral) and its purpose is to provide AC power disconnection. Maximum inrush current must not exceed 3A.

This figure shows optional components not furnished with control.

See Recommended Tightening Torques in Section 9.

Figure 4-9 Size 1 & 2 Internal Logic Transformer Jumper Locations

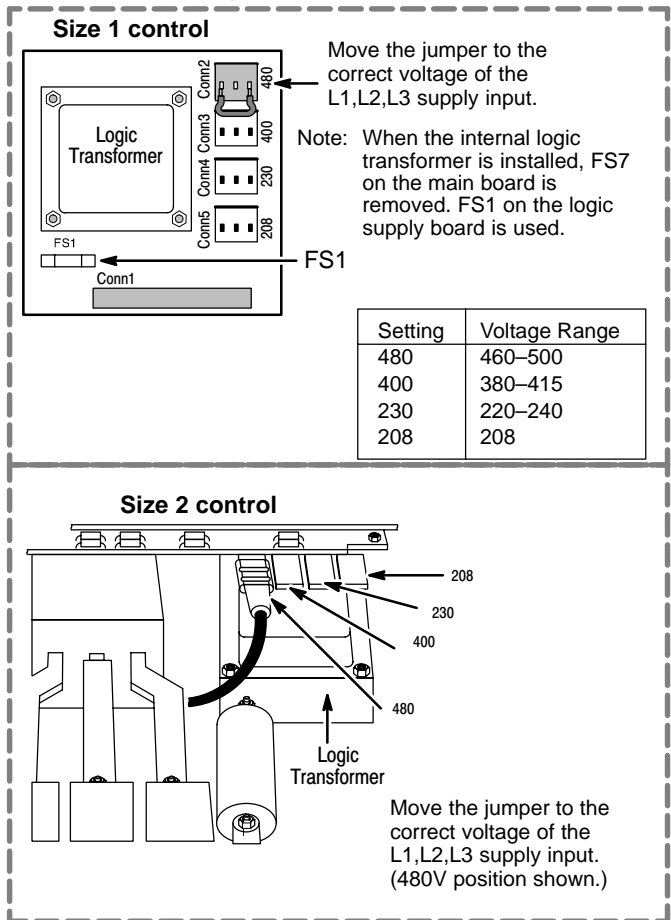
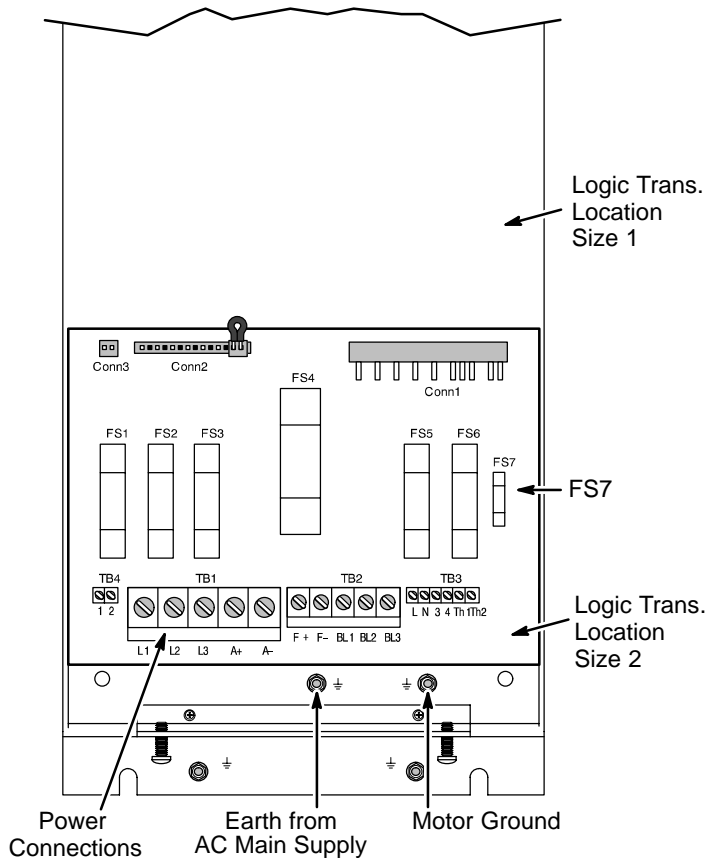

See Recommended Tightening Torques in Section 9.

Logic Power For size 1 and 2 controls, the logic transformer is internal. The location is shown in Figure 4-9. Because the logic transformer is powered from the L1,L2,L3 input AC power, the jumper must be placed in the location that corresponds to the AC line voltage.

For size 3, 4 and 5 controls the single phase logic power must be supplied by an external source. Normally 115VAC is applied at TB3 terminals L and N, see Figure 4-7 for the location. (Your control may have been ordered with 230VAC logic power. In that case, 230VAC is applied at TB3 terminals L and N.)

Electrical Installation Continued

Motor Connections Motor connections are shown in Figure 4-10. (The location of these terminals is shown in Figure 4-9).

Note: If your motor requires more than 85% of the line voltage as its DC input voltage, a step up transformer is required. This is added between the incoming line terminals and the L1 and L2 terminals of the field supply module. This connection is phase sensitive with main input L1 and L2.

Figure 4-10 Motor Connections

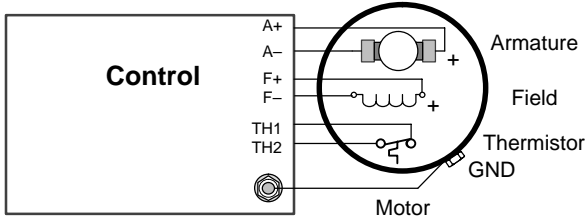

Notes:

1. Shield wires inside a metal conduit.
2. Metal conduit should be used to shield output wires (between control and motor). Connect conduits for continuous EMI/RFI shielding.

See Recommended Tightening Torques in Section 9.

Note: The control may be connected to a permanent magnet field DC motor. In this case, the field supply is not connected and the "Field Enable" [170] parameter must be set to "Disable".

Shunt Wound

Typical shunt wound motor field connection 120/240V or 150/300V. Consult manufacturers specific motor data for details.

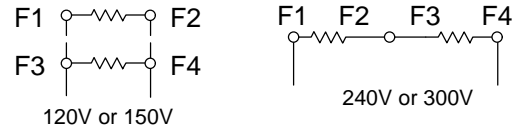

See Recommended Tightening Torques in Section 9.

External AC Field (Not available for size 1 controls)

The internal motor field is more widely used, it provides up to 90% of rated AC main voltage to the field windings. However if an external field supply is required (an application that requires more field voltage than 90% of AC main), terminals FL1 and FL2 can be used. The magnitude of this voltage is determined by the desired field voltage. The external supply must be protected with suitable fuses and disconnect. Always derive the supply from the Red and Yellow phases of the main power supply, with the Red phase connected to FL1 and the Yellow phase to FL2 (see jumpers in the External Field Connections diagrams).

Figure 4-11 External Field Connections

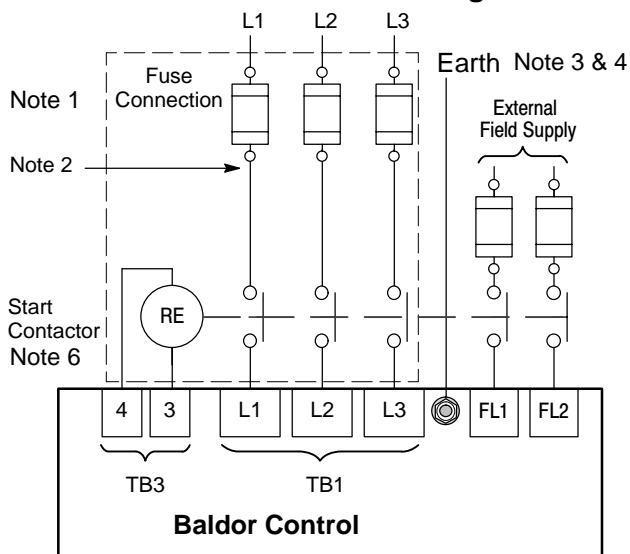

Notes:

1. See Protection Device description in this section.
2. Metal conduit or shielded cable should be used. Connect conduits so the use of a Reactor or RC Device does not interrupt EMI/RFI shielding.
3. Use the same gauge wire for Earth as used for L1, L2, L3 connections.
4. Use same gauge wire for Earth ground as is used for L and N. (VDE (Germany) requires 10mm² minimum, 6AWG).
5. Reference EMC wiring in Appendix A for CE compliance.
6. AC Contactor is internal for size 1 and 2 controls. Size 3–5, the contactor can be connected between TB3–3 (line) and TB3–4 (neutral) and its purpose is to provide AC power disconnection. Maximum inrush current must not exceed 3A.

This figure shows optional components not furnished with control.

See Recommended Tightening Torques in Section 9.

Electrical Installation Continued

External Field Terminal and Jumper Locations – Size 2

The position of the jumper selects the board to use either an internal or external motor field.

Figure 4-12 External Field Sensor Plug Jumper Settings

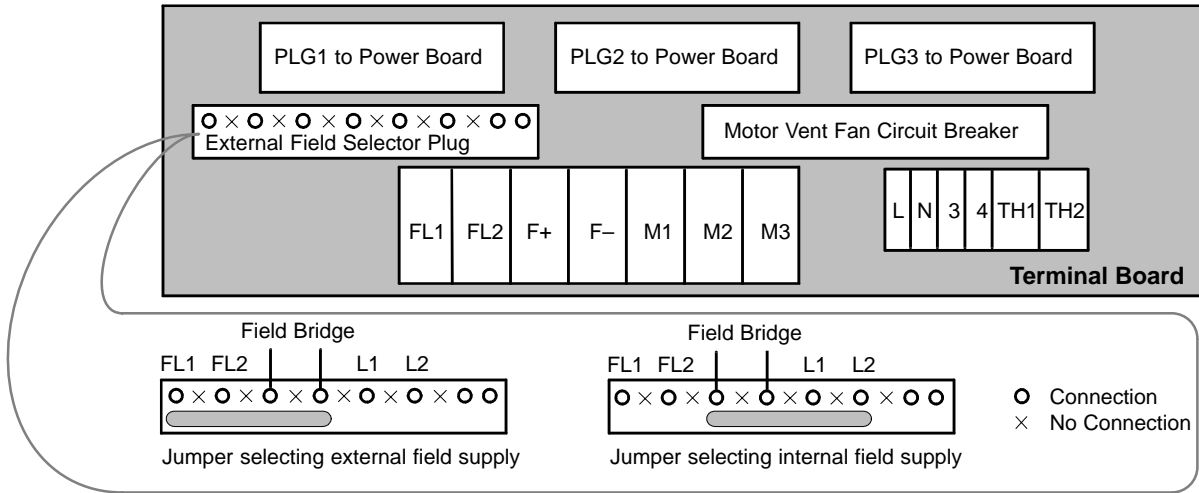

See Recommended Tightening Torques in Section 9.

External Field Terminal and Jumper Locations – Size 3

Relocating the Red and Yellow phase wires (as shown in Figure 4-13) allows terminals D1 and D2 on the Power Board to be used as the external field AC supply connections. External fuse must not exceed 10A.

Figure 4-13 External Field Connections
Power Board

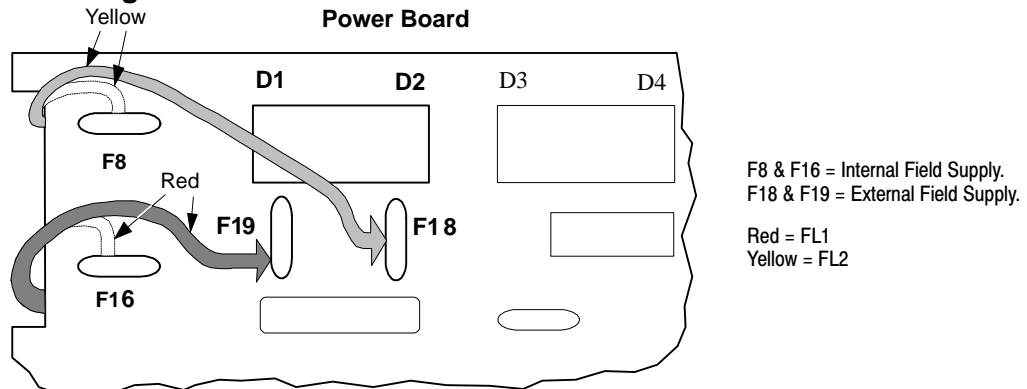

Procedure:

1. Remove the control board (2 screws secure it) to allow access to the power board.
2. Remove the red phase lead from connector "F16" on the left-hand side of the board.
3. Connect the red phase lead to connector "F19" located below D1.
4. Remove the yellow phase lead to connector "F8" on the left-hand side of the board.
5. Connect the yellow phase lead to connector "F18" located below D2.
6. Connect L1 to D1, and L2 to D2. When using an external AC input it is important to have the correct phase relationship on the terminals. The supply must be derived from L1 (Red) and L2 (Yellow) phases directly or indirectly through a single phase transformer. L1 must be connected to D1, and L2 connected to D2.

Electrical Installation Continued

External Field Terminal and Jumper Locations – Size 4 and 5

Relocating the Red and Yellow phase wires (as shown in Figure 4-14) allows terminals FL1 and FL2 to be used as the external field AC supply connections. External fuse must not exceed 30A.

Figure 4-14 External Field Connections

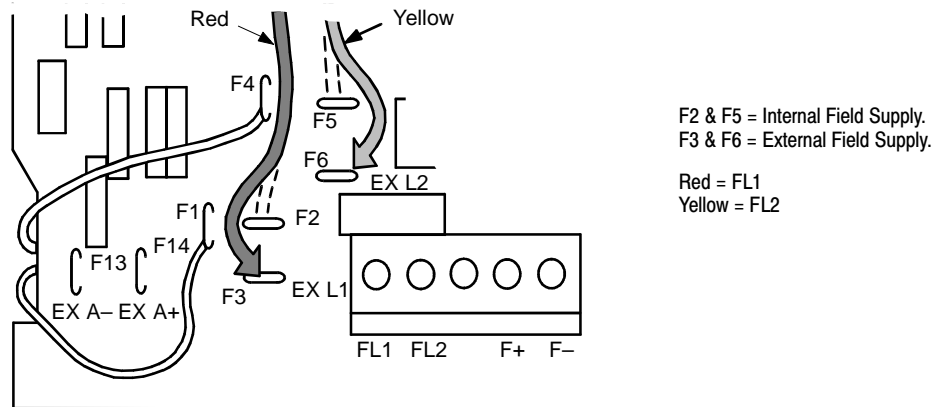

Procedure:

1. Remove the control board (2 screws secure it) to allow access to the power board.
2. Remove the red phase lead from connector “F2” on the left-hand side of the board.
3. Connect the red phase lead to connector “F3” located near the EX L1 terminal.
4. Remove the yellow phase lead to connector “F5” on the left-hand side of the board.
5. Connect the yellow phase lead to connector “F6” located near the EX L2 terminal.
6. Connect L1 to FL1, and L2 to FL2. When using an external AC input it is important to have the correct phase relationship on the terminals. The supply must be derived from L1 (Red) and L2 (Yellow) phases directly or indirectly through a single phase transformer. L1 must be connected to FL1, and L2 connected to FL2.

M-Contactor

If required by local codes or for safety reasons, an M-Contactor (motor circuit contactor) may be installed. However, incorrect installation or failure of the M-Contactor or wiring may damage the control. If an M-Contactor is installed, the control must be disabled for at least 20msec before the M-Contactor is opened or the control may be damaged. M-Contactor connections are shown in Figure 4-15.

Figure 4-15 Optional M-Contactor Connections

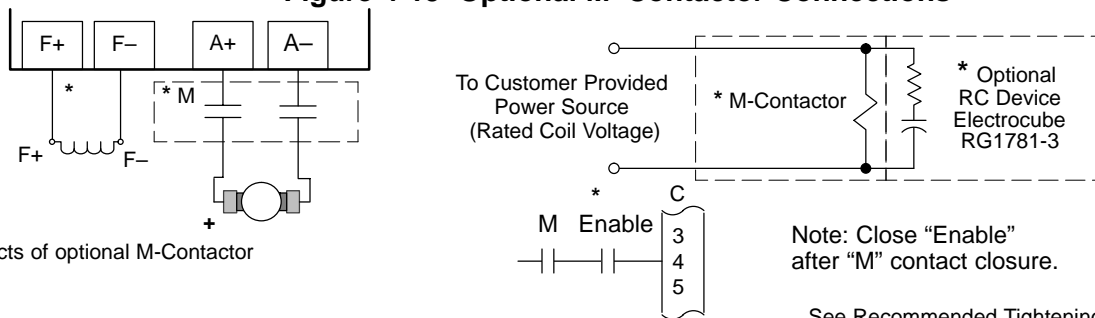

M=Contacts of optional M-Contactor

Control faults may occur if the control is enabled before the M Contactor is closed. The timing diagram shown in Figure 4-16 defines the correct operating sequence.

At Turn ON

Allow 20 milli seconds for the coil of the M contactor to energize and close the contactor before the Enable input at C-4 is issued.

At Turn OFF

Do not allow the M Contactor to open until motor shaft rotation has stopped and the Enable at C-4 has been removed. If this sequence does not occur, a TACH LOSS fault may be issued by the control.

Note: This example shows a “Drive ON” output to a PLC that is used to command the DC control and the holding brake.

Figure 4-16 M Contactor Operation Sequence

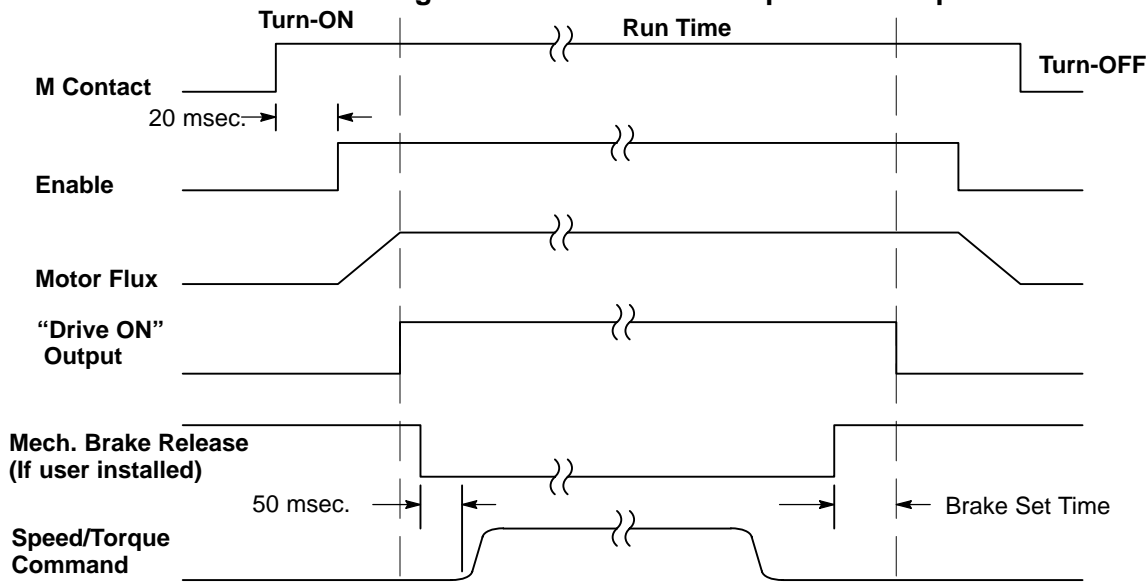

Blower Motor Starter Optional Size 1 and 2 controls only.

Size 1 and 2 controls can be equipped with an optional blower motor starter that uses a manual motor circuit controller to provide motor overload and branch circuit protection for a single or three phase AC blower motor. The starter assembly is fully wired and ready for site installation. This option offers

- Branch circuit protection
- Instantaneous magnetic short circuit protection
- Thermal overload protection, Class 10, with adjustable trip current settings
- Start/Stop/Reset switching with “tripped” pushbutton indication
- Normally open auxiliary contact wired into the drive logic to indicate “Motor Overtemperature” trip

Installation

1. Open the cover to view the fuse board (Figure 4-3).
2. Position the starter assembly horizontally across the top of the drive so that the harness points downward toward the power terminals.
3. Align the bracket with its mounting slots on the inside walls of the drive. Snap into place with a firm push until the tabs engage.
4. Locate the 14 pin header for the blower motor starter connections.
For size 1, this connector is CONN 2, located at the top left corner of the fuse board.
For size 2, this connector is CONN 44 located at the right edge of the terminal board.
5. This connector has a jumper installed at the right most two pins. Remove and save this jumper.
6. Plug the 14 pin connector from the blower motor starter onto this connector.
7. Use a small screwdriver to set the full load current of the blower motor on the dial of the blower motor starter.
8. Connect the blower motor leads to terminals BL1, BL2, BL3 (Figure 4-7).
9. Press the Start button on the blower motor starter. Installation is now complete.

Electrical Installation Continued

Thermal Protection Terminals TB3 TH1 and TH2 are available for connection to a normally closed thermostat or overload relay in all operating modes as shown in Figure 4-17. The thermostat or overload relay should be a dry contact type with no power available from the contact. If the motor thermostat or overload relay activates (opens), the control will automatically shut down and give an Thermistor fault. The optional relay (CR1) shown provides the isolation required and the N.O. contact is closed when power is applied to the relay and the motor is cold. If the motor thermostat is tripped, CR1 is de-energized and the N.O. contact opens. Connect the motor thermal wires (N.O. relay contact) to TH1 and TH2. Do not place these wires in the same conduit as the motor power leads.

Figure 4-17 Motor Temperature Relay

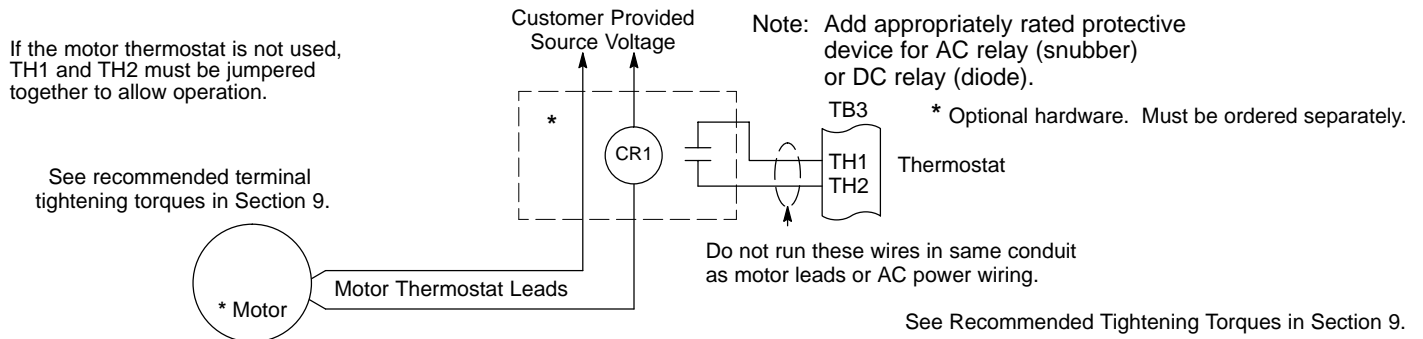

Encoder Installation Electrical isolation of the encoder shaft and housing from the motor is required. Electrical isolation prevents capacitive coupling of motor noise that will corrupt the encoder signals. Baldor provides shielded wire for encoder connection. Table 4-6 defines the encoder connections to the encoder receiver expansion board. Figure 4-18 shows the electrical connections of the encoder. The expansion board is installed in the feedback EXB location shown in Figure 4-2.

1. Open the top cover (Figure 4-1).
2. Align the 10 pin connector on the board with the connector on the left side of the control.
3. Carefully push the encoder board into position being careful not to bend any pins. All four stand-offs should contact the control.
4. Connect the encoder wires to the expansion board, see Table 4-6 and Figure 4-18.

Table 4-6 Encoder Connection Descriptions

Description	Encoder Connector No.	Encoder Receiver Board Pin.
A	A	3
A	A	4
B	B	5
B	B	6
C	C	
C	C	
+VCC Supply	+VCC Supply	2
Not used (VCC Sensor)	Not used (VCC Sensor)	
0VDC	0VDC	1
Not used (0VDC Sensor)		
Cable Shield		

Figure 4-18 Differential Encoder Connections

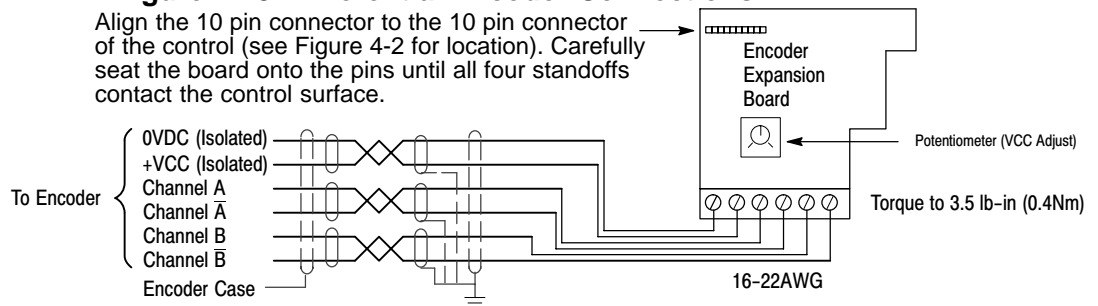

Electrical Installation Continued

Tachometer Installation The tachometer expansion board can be used to connect either an AC Tach or a DC Tach to the control (only one may be used). Shielded wire must be used for tachometer connection. Table 4-7 defines the tachometer connections to the tachometer expansion board. Figure 4-19 shows the electrical connections of the tachometer. Figure 4-20 shows the settings for this board.

Note: DC Tachometers provide speed and direction feedback. AC tachometers provide only speed feedback.

Table 4-7 Tachometer Connection Descriptions

Description	Tachometer Receiver Board Pin.
AC Tach Input	1
AC Tach Input	2
DC Tach Input +	3
DC Tach Input - (0VDC)	4

Figure 4-19 Tachometer Connections

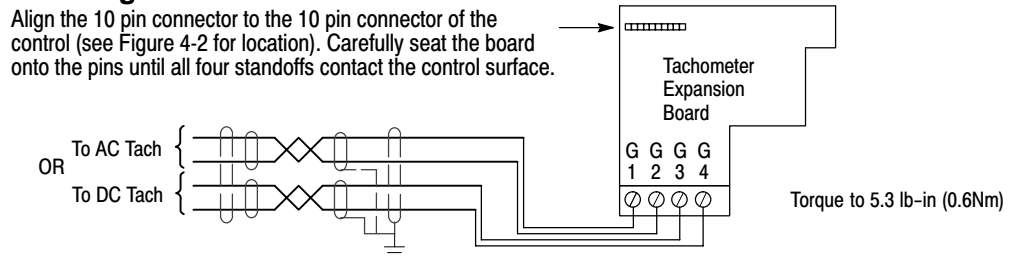

Figure 4-20 Switch Settings

Calibration Switches { SW1 = Ones calibration switches.
SW2 = Tens calibration switches.
SW3 = Down adds 100 VDC in the down position (100's position).
SW4 = Up for AC Tach; Down for DC Tach.

As shown, switches are set for 188VDC for a DC tach:
(SW3 + SW2 + SW1 = 100 + 80 + 8 = 188)

The jumper is always used. It plugs onto the control PCB in just about the position shown. This jumper is where the actual scaled signal connects from the Tach board to the controller PCB.

For full speed tach voltages greater than 200V, an external resistor of value RE must be used in series with the DC Tach connection at G3. The value RE is calculated as follows:

$$RE \text{ ohms} = \frac{(\text{Max Tach Volts} - 200)}{5} \text{ k}\Omega$$

$$RE \text{ Watts} = (\text{Max Tach Volts} - 200) \times 5 \text{ milliwatts}$$

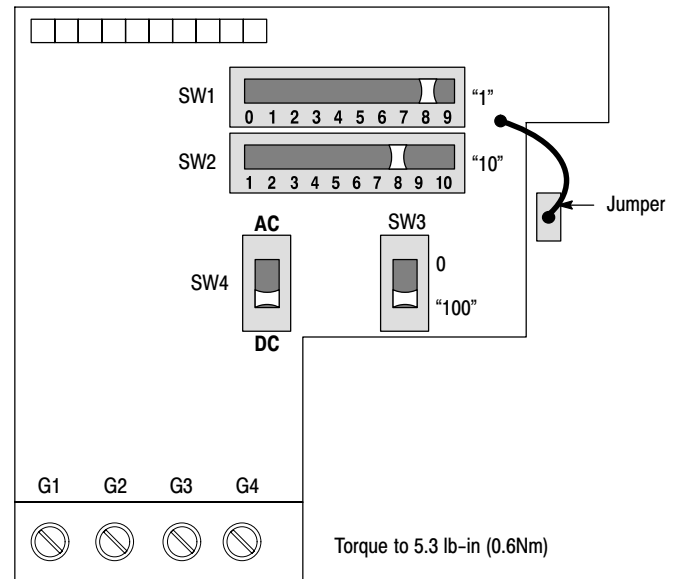

In general, the voltage output of an analog AC or DC tachometer generator is a function of speed and is rated in volts per 1000 RPM so that:

$$\text{Speed Feedback Voltage}_{\text{Max}}(\text{volts}) = \text{Motor Speed}_{\text{Max}}(\text{RPM}) \times \text{Tach Rating}$$

The Tach Rating should be on the nameplate of the tachometer generator. Fine tuning is performed within the software (refer to the Speed Feedback Calibration). If the full speed feedback voltage exceeds 200 VDC, use an external resistive scaling network to drop the feedback voltage to within this range.

For AC tachometer generators, the switch settings will be about 1.3 times greater than the voltage measured at the input terminals G1 and G2 due to the rectifier offset. For example, for 90V feedback, the switch setting is:

$$\sqrt{2} \times \text{Required Voltage Feedback} = \sqrt{2} \times 90 = 127V.$$

Control I/O Signal Connections

All connections made to terminal blocks A, B and C must be isolated signal voltages. If in doubt a connection, contact Baldor. Only shielded, twisted pair cables should be use. Minimum wire size is 18AWG (0.75mm²). All cables should be installed using the appropriate coupling in the knock out panel, shown in Figure 4-3.

Analog Inputs Five analog inputs are available, AnIn1 – AnIn5 (AnIn4 and AnIn5 are factory set for current limits).

Connector Terminal	Signal Description
A1	0V common reference point for all analog signals.
A2	Analog Input 1. 0–20 or 4–20mA analog input speed input. Used as a unipolar 0–20mA ramped speed command channel. 4–20mA requires manually setting Min value to 25%, Max Value to 125% and setting Setpoint Sum1, Input 2 to (–)25%. These settings will provide the proper scaling and offset to set 4mA to zero command. Any input less than 4mA will result in a Min Value of 25% being added to (–)25% at the Setpoint Sum 1 summing junction.
A3	Analog Input 2. ±10V analog input speed or torque reference without Accel/Decel ramps. +10V = maximum forward speed demand. –10V = maximum reverse speed demand. Closing C8 (Digital Input 3) selects Torque Command Mode by enabling the IDMD Isolate input (Current Loop Block). Opening C8 selects Speed Command Mode by disabling the IDMD Isolate input. In all cases this analog command channel bypasses the Ramps Block.
A4	Analog Input 3. ±10V analog input speed or torque reference with Accel/Decel ramps. By closing the Reverse input at C5, the direction of the unipolar command can be changed. Output of Ramps block is connected to Setpoint 1 of the Speed Loop block. Various voltage range, and bipolar or unipolar commands can be accepted by adjusting Calibration, Max Value, and Min Value parameters of Analog Input 3.
A5	Analog Input 4. Optional Negative Current Clamp. Inactive until Bipolar Clamps parameter is set to Enable. When enabled, this input is the value of the negative current limit.
A6	Analog Input 5. External Current Limit / Optional Positive Current Clamp. A jumper is supplied from B3 (+10V Ref) to A5 to allow full rated 150% current. When Bipolar Clamps parameter is set to Disabled, this input is the main current limit value. When Bipolar Clamps parameter is set to Enable, this input value is the positive or forward current limit.

Note: The settings for AnIn1 – AnIn5 are factory set but can be changed to suit your application.

Speed Setpoint

The speed demand signal can be generated using an external 10K potentiometer as shown in Figure 4-21. The wiper is the speed reference.

Figure 4-21 Analog Inputs

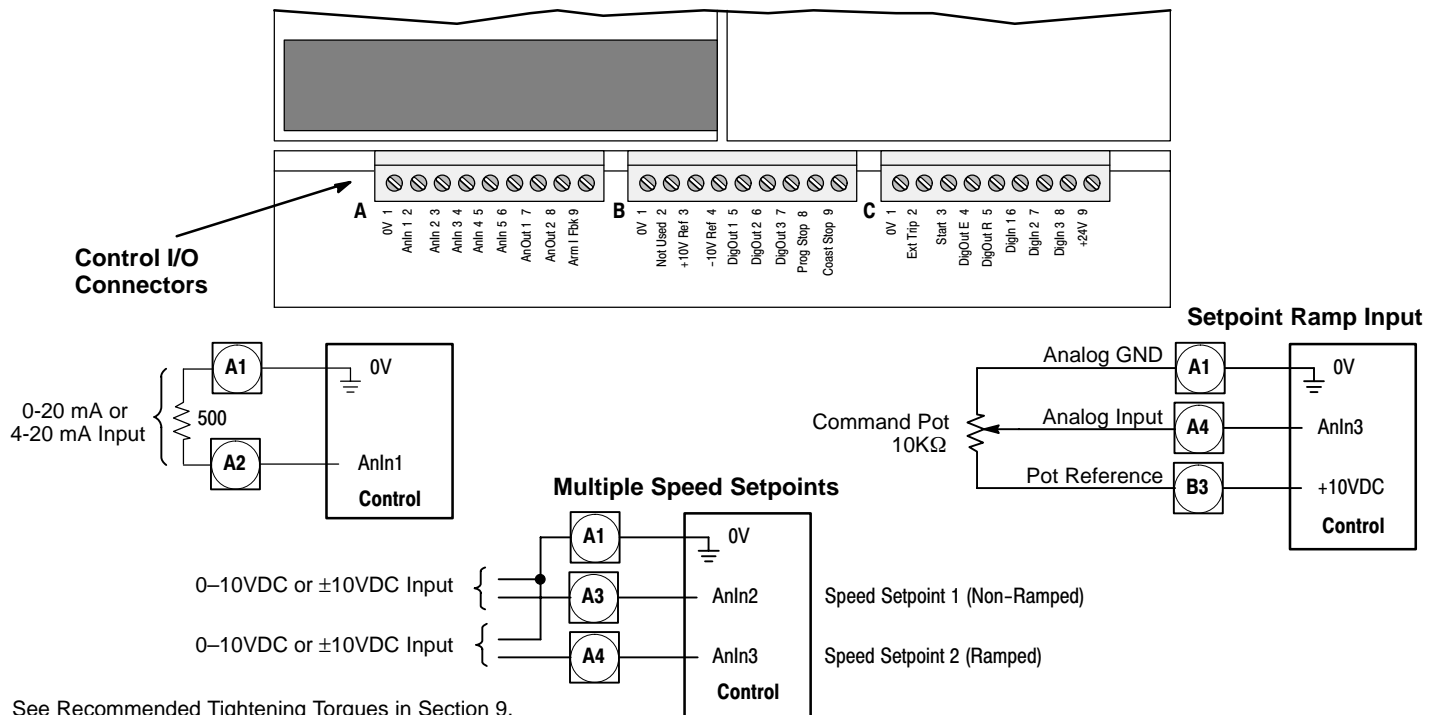

See Recommended Tightening Torques in Section 9.

Control I/O Signal Connections Continued

Analog Outputs

Connector Terminal	Signal Description
A7, A8, A9	Three analog outputs are available, AnOut1 – AnOut3. A1 is the 0V common reference point.

Figure 4-22 Analog Outputs

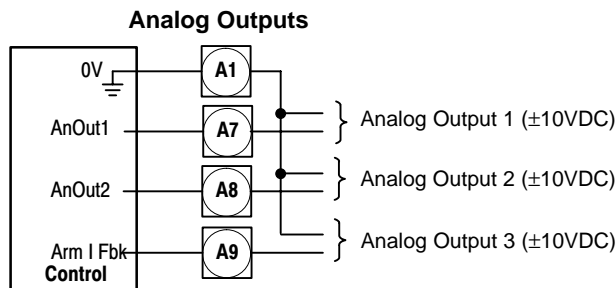

See Recommended Tightening Torques in Section 9.

Digital Inputs C4 (Enable) must be connected to C9 (+24V) to allow the drive to run when start command is given.

Connector Terminal	Signal Description (factory settings)
B8	Program Stop. When opened runs a decel rate set by Stop Rates, Prog Stop Time.
B9	Coast Stop. When opened disables the drive output.
C2	External Trip. When opened disables the drive output and creates an External Trip Fault.
C3	Start/Stop. Closed initiates a Start/Run forward sequence. When opened commands Stop and decels at Stop Rates, Stop Time setting.
C4	Enable. Closed enables the drive and allows output to the motor.
C5	Reverse. Closed changes the slope of the speed command signal from Analog Input 1 and Analog Input 2. Accomplished by activating the "Ramp Invert" input of the Ramps block.
C6	Jog / Slack. If terminal C4 is closed and Start/Stop terminal C3 is open, motor will be commanded to run forward at Jog Speed 1. If terminal C4 is closed and Start/Stop terminal C3 is closed, motor will be commanded to run forward at active speed setpoint plus Jog/Slack Take Up 1 speed. Various Jog or Slack take-up functions Various Jog or Slack take-up functions are commanded depending on the various settings of terminals C3, C4 and Jog/Slack Mode C7.
C7	Jog/Slack Mode. See Jog/Slack description in Section 6 for description of modes.
C8	Speed/Torque Select. Open selects speed (velocity) mode. Closed selects current (torque) mode. Accel/Decel ramps are not used in Torque mode.

Start (C3), Enable (C4), Reverse (C5), Program Stop (B8) and Coast Stop (C9).

The basic Run/Start sequence is initiated by C3 (Start/Run). Other safeguards are provided by B8 (Program Stop) and B9 (Coast Stop). Assuming that the Program Stop and Coast Stop terminals are held TRUE, then a single contact connected between C9 (+24V) and C3 (Start/Run) when closed will cause the control to energize the Main Contactor and when C5 (Enable) is also TRUE the motor will rotate.

When the single contact to C3 (Start/Run) is opened, the controller will decelerate the motor to zero speed at a rate determined by the STOP TIME parameter value and the MAIN CURR. LIMIT value. If the load is to be serviced, the control must be securely disabled and isolated, do not rely on this mode.

Control I/O Signal Connections Continued

Figure 4-23 Run/Stop Connections

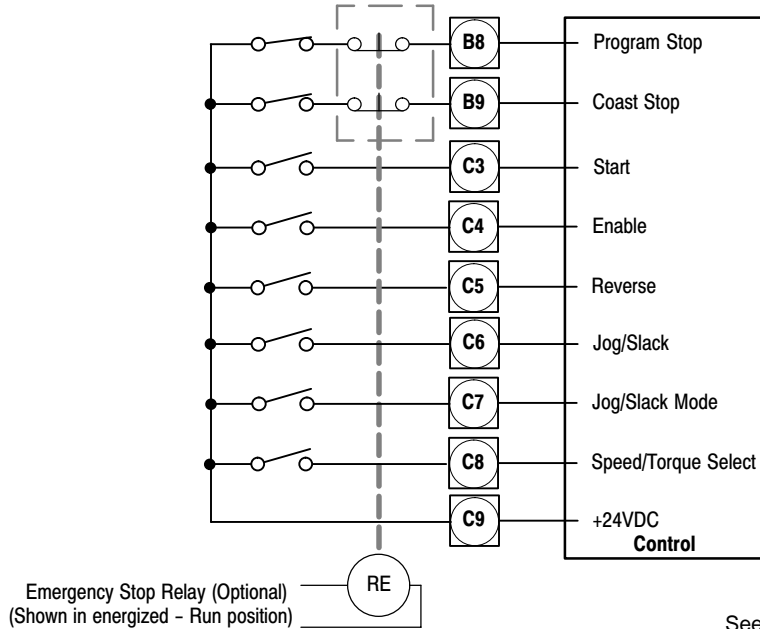

See Recommended Tightening Torques in Section 9.

A regenerative drive can be stopped using a Normal Stop, a Program Stop, or an Emergency Stop.

Normal Stop

If the +24V is removed from C3 during operation, the control will cause the motor to stop at a rate determined by Stop Limit, Stop Time and Curr. Limit.

Program Stop

If the +24V is removed from B8 during operation, the control will cause the motor to stop at a rate determined by Prog Stop I Lim, Prog Stop Limit and Prog Stop Time. If +24V is re-applied to B8, the motor remains stationary until a new Start command is applied to C3 (Start/Run).

Coast Stop

If the +24V is removed from B9 during operation, the control will remove power to the motor and the motor and load will coast to a stop.

Emergency Stop (Optional)

When the "Emergency Stop Relay" is de-energized its contacts disconnect +24VDC from the inputs shown in Figure 4-23. The control will remove power to the motor and the motor and load will coast to a stop. The emergency stop relay should not be part of the normal sequencing of the system, but is an emergency operation when safety is the main concern. If the load is to be serviced, the control must be securely disabled and isolated, do not rely on this mode.

Digital Outputs

Connector Terminal	Signal Description
B5, B6, B7	Three digital outputs are available, DigOut1 – DigOut3. B1 is the 0V common reference point.

These digital output terminals provide a +24VDC output signal under certain conditions. An LED, Lamp, Relay or other device can be connected at these outputs to indicate the condition of control operation. These are configurable outputs and can be used as required in the control system design, i.e. panel lamps, connection to a suitable PLC. Simply connect a 24VDC relay between the output and B1 (0VDC). Be sure to use a reverse biased diode or other noise elimination device across the relay coil, see Figure 4-24.

Figure 4-24 Optional Digital Output Relay Connection

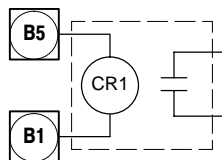

Note: Add appropriately rated protective device for AC relay (snubber) or DC relay (diode).

RS232 Connections

- 1 SERIAL LINKS
- 2 SYSTEM PORT P3
- 3 P3 SETUP
 - MODE
 - P3 BAUD RATE

The keypad connector shown in Figure 4-25 is used for RS232 communications. Workbench D is the block programming software for Windows PCs. It has a graphical user interface and drawing tools to allow you to create block programming diagrams quickly and easily.

Figure 4-25 System Port (P3) Keypad Connector

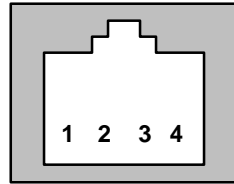

View into the connector.

A null modem cable (also called a modem eliminator cable) must be used to connect the control and the computer COM port. This will ensure that the transmit and receive lines are properly connected. Either a 9 pin or a 25 pin connector can be used at the computer, Figure 4-26. Maximum recommended length for RS232 cable is 10 ft. (3 meter).

Figure 4-26 9 & 25 Pin RS-232 Cable Connections

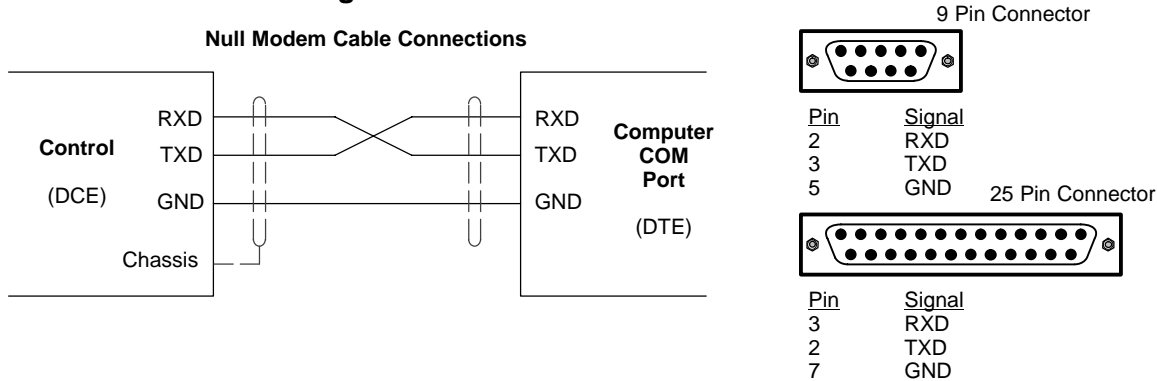

Table 4-8 Cable Connections

P3 Connector		DB Connector Type and Pin Number	
Pin	Signal Name	DB9	DB25
1	GND/0VDC	5	7
2	24VDC		
3	RXD	2	3
4	TXD	3	2

System Port (P3) Configuration

The factory port settings are normally fine. These settings are:

- 9600 Baud
- 8 Bits
- 1 Stop Bit
- No Parity
- XON/XOFF Handshaking (fixed)

If the port settings must be changed, attach a keypad to the control and change the settings under the P3 SETUP menu. Refer to Keypad Operation for additional information to make these parameter value changes.

Section 5 Switch Setting and Start-Up

Pre-Operation Checks

When the installation is complete, several things should be verified before power is applied.

1. Be sure AC power is off at the main disconnect or circuit breakers.
2. Measure the main AC supply voltage (to the disconnect or breaker) and verify that it matches the nameplate rating of the control.
3. If the catalog number on the nameplate ends with "CO1", an external 115VAC logic control supply is required (C02= 230VAC Logic). Verify Auxiliary power supply voltage is correct.
4. Verify the armature voltage and current ratings of the motor are correct.
5. Inspect all power connections (line and motor) for accuracy, workmanship tightness and compliance to codes.
6. Verify that the control and motor are grounded to each other and that the control is connected to earth ground.
7. Verify all signal wiring for accuracy and tightness.
8. Be certain that all contactor, brake or relay coils have noise suppression. This should be an RC filter for AC coils or a reverse biased diode for DC coils. MOV type transient suppression is not adequate.
9. Disconnect the load from the motor shaft if possible.
10. If possible, verify the motor shaft rotates freely.
11. Verify the cooling fan (blower) is free from obstruction.
12. Verify that the external run contacts are open.
13. Verify that external speed setpoints are all zero.

Size 4 and 5 Only – Power Board Calibration

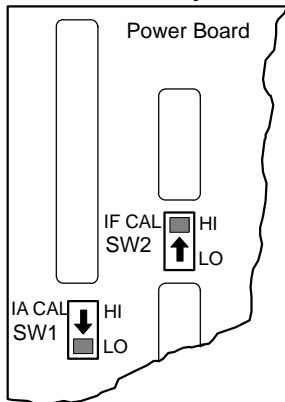

IA CAL – Armature Current Calibration Switch (SW1)

This switch is always set to LO on Frame 4 & 5 drives of less than 500A, and HI for drives greater than 500A.

F CAL – Field Current Calibration Switch (SW2)

This switch should always be set to HI for Frame 4 & 5 drives. The maximum field current calibration is 30A.

Power up in Local Mode with Armature Feedback

When pre-operation checks are complete, logic power can be applied to terminals L and N to setup the software parameters (catalog number C01=115VAC, C02=230VAC). For other catalog numbers (100hp and less), the logic power is provided internally so 3 phase power must be applied at this time.

(The start up mode is defined by Parameter [517] =True for keypad operation which is the same as "SETUP PARAMETERS::OP STATION::START UP VALUES::LOCAL = TRUE".)

Note: To separate the various menu level designation, a double colon is used (SETUP PARAMETERS::OP STATION).

1. Apply logic power.
2. Verify that the keypad and LED's display correctly. If not, verify that the logic wiring is correct.

Action	Description	Display	Comments
Apply Logic Power at terminals L and N	Keypad Display shows this opening message. If [517] is True, local mode will be displayed (factory setting)	INITIALIZING	LED's are all ON.
		BALDOR DC DRIVE CALIBRATING	LED's are flashing. After several seconds the next screen is displayed.
		FORWARD REF: 0.00%	The OK, SEQ, REF, FWD and STOP LED's are on.

Power up in Local Mode with Armature Feedback Continued

3. Set the parameter Configure Enable to "Enabled".

Action	Description	Display	Comments
Apply Logic Power	Keypad Display shows this opening message. Access the menus. Scroll to "Configure Drive" menu. Access Configure Drive menu. Access the Configure Enable parameter. Enable Configure Enable. Returns to previous menu level.	FORWARD REF: 0.00%	LED's are flashing. After several seconds the next screen is displayed. All LED's are now flashing. Press "E" when done.
Press "PROG" key		BALDOR DC DRIVE DC 4Q 35A	
Press "M" key		DC 4Q 35A MENU LEVEL	
Press "M" key		MENU LEVEL DIAGNOSTICS	
Press ▲		MENU LEVEL CONFIGURE DRIVE	
Press "M" key		CONFIGURE DRIVE CONFIGURE ENABLE	
Press "M" key		CONFIGURE ENABLE DISABLED	
Press ▲		CONFIGURE ENABLE ENABLED	
Press "E" key		CONFIGURE DRIVE CONFIGURE ENABLE	

4. Set the Nominal Motor Volts (Armature Voltage) in the Configure Drive menu.

Action	Description	Display	Comments
Press ▼	Scroll to the NOM Motor volts parameter. Access the NOM Motor Volts parameter	CONFIGURE DRIVE CONFIGURE ENABLE	Press ▲ to change to current control if desired. Press "E" when done.
Press "M" key		CONFIGURE DRIVE NOM MOTOR VOLTS	
Press "PROG" key		NOM MOTOR VOLTS 180 VOLTS	

5. Set the Armature Current. Note the maximum armature current from the motor name plate and set this value in the Armature Current parameter.

Action	Description	Display	Comments
Press ▼	Scroll to the Armature Current parameter. Access the Armature Current parameter	CONFIGURE DRIVE CONFIGURE ENABLE	Press ▲ to change to current control if desired. Press "E" when done. Max value is hardware limited. Note: Holding the M key scrolls the cursor the left most digit so it can be changed more quickly.
Press "M" key		CONFIGURE DRIVE ARMATURE CURRENT	
Press "PROG" key		ARMATURE CURRENT 11.5 AMPS	

Power up in Local Mode with Armature Feedback Continued

6. Set the Field Current. Note the nominal field current from the motor rating plate and set this value in the Field Current parameter.

Action	Description	Display	Comments
Press ▼	Scroll to the Field Current parameter.	CONFIGURE DRIVE CONFIGURE ENABLE	Press ▲ to change to current control if desired. Press “E” when done. Max value is hardware limited.
Press “M” key	Access the Field Current parameter	CONFIGURE DRIVE FIELD CURRENT	
Press “PROG” key		FIELD CURRENT 0.2 AMPS	

7. Set the Field Control Mode to Field Voltage or Field Current control. Refer to section 6 for more information. The factory setting is Voltage Control mode.

Action	Description	Display	Comments
Press ▼ several times	Scroll to the field control mode parameter.	CONFIGURE DRIVE CONFIGURE ENABLE	Press ▲ to change to current control if desired. Press “E” when done.
Press “M” key	Access the field control mode	CONFIGURE DRIVE FLD CTRL MODE	
Press “PROG” key		FLD CTRL MODE VOLTAGE CONTROL	

8. Set the Field Volts Ratio. Enter the calculated ratio into the parameter given by the equation: A setting of 90% is the maximum value obtainable, i.e. field output = 0.9 x VAC
- $$100 \times \frac{\text{FieldVolts (Nameplate)}}{\text{Input Volts AC}_{\text{RMS}}}$$

Action	Description	Display	Comments
Press ▼	Scroll to the field volts ratio parameter.	CONFIGURE DRIVE FLD CTRL MODE	Press ▲ to increase the value if desired. Press “E” when done.
Press “M” key		CONFIGURE DRIVE FLD VOLTS RATIO	
Press “M” key	Access the menus.	FLD VOLTS RATIO 0.00%	
Press ▲	Scroll to “Configure Drive” menu.	CONFIGURE DRIVE FLD VOLTS RATIO	

9. Set the Configure Dive::Configure Enable parameter to disable (see step 3).
10. Save the settings.

Action	Description	Display	Comments
Start at Menu Level 1		MENU LEVEL DIAGNOSTICS	Parameters are saved. Except the “Local Setpoint”. Press “E” several times to return to the top level.
Press ▼	Scroll to “PARAMETER SAVE” menu.	MENU LEVEL PARAMETER SAVE	
Press “M” key		PARAMETER SAVE UP TO ACTION	
Press ▲	Press ▲ to save parameters.	PARAMETER SAVE REQUESTED	
Press “E” key	Exit one level	MENU LEVEL PARAMETER SAVE	

Power up in Local Mode with Armature Feedback Continued

The control is now ready to run from the keypad using armature feedback.

1. The logic power is still applied, the keypad display is normal, the motor is connected but the load is removed.
2. Apply 3 phase power.
3. Verify that the keypad and LED displays are still normal, with no error messages.
4. Set the Speed Setpoint parameter to zero.
5. Verify that the Main CURR. Limit is set to 0.00%. View ANIN 5 (A6) parameter in the level 1 Diagnostics menu and verify it displays 0.00V.
6. Press JOG at the keypad. Verify that 3-phase mains is applied to Power Terminals L1, L2 and L3 and immediately check that the correct field voltage appears between the control supply terminals F+ and F-. If the field voltage is not correct, check one of the following:

Internally Supplied Field:

- a. Check that 3-phase is applied to terminals L1, L2 and L3 when the main contactor is closed.
- b. Check that the fuses on the power board or suppression board are healthy.
- c. Verify the Field Enable parameter is set to Enable.
- d. Is the FLD CTRL Mode parameter set to Voltage Control or Current Control?
If set to VOLTAGE CONTROL, check the value of the FLD. VOLTS RATIO parameter. Set this to 65% to obtain 300V fields from 460V lines.
If set to CURRENT CONTROL, check the field current calibration.
If the field volts are at maximum, check the field continuity. (The field current may initially be less than the rated value due to a cold field.)

Externally Supplied Field: (not available for size 1 and 2 controls)

- a. Refer to Chapter 4 Installation, Motor Field Connections for conversion details.
 - b. Check the voltage applied (externally fused) to terminals FL1 and FL2.
 - c. Check the phasing of voltage applied to FL1 and FL2:
FL1 must be connected directly or indirectly to the Red phase on main power terminal L1.
FL2 must be connected directly or indirectly to the Yellow phase on main power terminal L2.
 - d. Verify the Field Enable parameter is set to Enable.
 - e. Is the FLD CTRL Mode parameter set to Voltage Control or Current Control?
If set to Voltage Control, check the value of the FLD. Volts Ratio parameter. Set this to 65% to obtain 300V fields from 460V lines.
If set to Current Control, check the field current calibration set-up, refer to "Calibration".
7. Verify that the OK and STOP LEDs are On, also either the FWD or REV LED.

This verifies keypad operation of the control and motor. The control may be used in this mode after the load is connected or additional wiring changes can be made for operation from the terminal strip.

Power up in Remote Mode with Feedback This procedure assumes that the terminal strip (connectors A, B C) are wired according to the instructions provided in Section 4 and the feedback device is properly installed. (The start up mode is defined by Parameter [517] =False for remote operation which is the same as "SETUP PARAMETERS::OP STATION::START UP VALUES::LOCAL = FALSE".)

When pre-operation checks are complete, logic power can be applied to setup the software parameters. At this point, 3 phase power should remain off, if possible.

1. Apply Logic power.
2. Verify the keypad and LED's display correctly. If not, verify that the logic wiring is correct.

Action	Description	Display	Comments
Apply Logic Power	Keypad Display shows this opening message. The local mode (keypad mode) is displayed	BALDOR DC DRIVE CALIBRATING FORWARD REF: 0.00%	LED's are flashing. After several seconds the next screen is displayed. The OK, SEQ, REF, FWD and STOP LED's are on.

3. Set the parameter Configure Enable to "Enabled".

Action	Description	Display	Comments
Apply Logic Power	Keypad Display shows this opening message.	FORWARD REF: 0.00%	LED's are flashing. After several seconds the next screen is displayed.
Press "PROG" key		BALDOR DC DRIVE DC 4Q 35A	
Press "M" key		DC 4Q 35A MENU LEVEL	
Press "M" key	Access the menus.	MENU LEVEL DIAGNOSTICS	
Press ▲	Scroll to "Configure Drive" menu.	MENU LEVEL CONFIGURE DRIVE	
Press "M" key	Access Configure Drive menu.	CONFIGURE DRIVE CONFIGURE ENABLE	
Press "M" key	Access the Configure Enable parameter.	CONFIGURE ENABLE DISABLED	
Press ▲	Enable Configure Enable.	CONFIGURE ENABLE ENABLED	All LED's are now flashing. Press "E" when done.
Press "E" key	Returns to previous menu level.	CONFIGURE DRIVE CONFIGURE ENABLE	

4. Set the Nominal Motor Volts (Armature Voltage).

Action	Description	Display	Comments
Press ▼	Scroll to the NOM Motor volts parameter.	CONFIGURE DRIVE CONFIGURE ENABLE	
Press "M" key	Access the NOM Motor Volts parameter	CONFIGURE DRIVE NOM MOTOR VOLTS	
Press "PROG" key		NOM MOTOR VOLTS 180 VOLTS	Press ▲ to change to current control if desired. Press "E" when done.

Power up in Remote Mode with Feedback Continued

5. Set the Armature Current. Note the maximum armature current from the motor name plate and set this value in the Armature Current parameter.

Action	Description	Display	Comments
Press ▼	Scroll to the Armature Current parameter.	CONFIGURE DRIVE CONFIGURE ENABLE	Press ▲ to change to current control if desired. Press “E” when done.
Press “M” key	Access the Armature Current parameter	CONFIGURE DRIVE ARMATURE CURRENT	
Press “PROG” key		ARMATURE CURRENT 11.5 AMPS	

6. Set the Field Current. Note the nominal field current from the motor rating plate and set this value in the Field Current parameter.

Action	Description	Display	Comments
Press ▼	Scroll to the Field Current parameter.	CONFIGURE DRIVE CONFIGURE ENABLE	Press ▲ to change to current control if desired. Press “E” when done.
Press “M” key	Access the Field Current parameter	CONFIGURE DRIVE FIELD CURRENT	
Press “PROG” key		FIELD CURRENT 0.2 AMPS	

7. Set the Field Control Mode to Field Voltage or Field Current control. Refer to section 6 for more information. The factory setting is Voltage Control mode.

Action	Description	Display	Comments
Press ▼ several times	Scroll to the field control mode parameter.	CONFIGURE DRIVE CONFIGURE ENABLE	Press ▲ to change to current control if desired. Press “E” when done.
Press “M” key	Access the field control mode	CONFIGURE DRIVE FLD CTRL MODE	
Press “PROG” key		FLD CTRL MODE VOLTAGE CONTROL	

8. Set the Field Volts Ratio. Enter the calculated ratio into the parameter given by the equation: A setting of 90% is the maximum value obtainable, i.e. field output = 0.9 x VAC
- $$100 \times \frac{\text{FieldVolts (Nameplate)}}{\text{Input Volts AC}_{\text{RMS}}}$$

Action	Description	Display	Comments
Press ▼	Scroll to the field volts ratio parameter.	CONFIGURE DRIVE FLD CTRL MODE	Press ▲ to increase the value if desired. Press “E” when done.
Press “M” key	Access the menus.	CONFIGURE DRIVE FLD VOLTS RATIO	
Press “M” key		FLD VOLTS RATIO 0.00%	
Press ▲	Scroll to “Configure Drive” menu.	CONFIGURE DRIVE FLD VOLTS RATIO	

Power up in Remote Mode with Feedback Continued

9. Set the Configure Dive::Configure Enable parameter to disable (see step 3).
10. Save the settings.

Action	Description	Display	Comments
Start at Menu Level 1		MENU LEVEL DIAGNOSTICS	
Press ▼	Scroll to "PARAMETER SAVE" menu.	MENU LEVEL PARAMETER SAVE	
Press "M" key		PARAMETER SAVE UP TO ACTION	
Press ▲	Press ▲ to save parameters.	PARAMETER SAVE REQUESTED	Parameters are saved. Except the "Local Setpoint".
Press "E" key	Exit one level	MENU LEVEL PARAMETER SAVE	Press "E" several times to return to the top level.

The control is now ready to run the motor.

1. The logic power is still applied, the keypad display is normal, the motor is connected but the load is removed.
2. Apply 3 phase power.
3. Verify that the keypad and LED displays are still normal, no error messages.
4. Set the Speed Setpoint parameter to zero.
5. Verify that the Main CURR. Limit is set to 0.00%. View ANIN 5 (A6) parameter in the level 1 Diagnostics menu and verify it displays 0.00V.
6. Apply the Start/Run command and check that 3-phase mains is applied to Power Terminals L1, L2 and L3. Initiate "Enable" (C4) and immediately check that the correct field voltage appears between the control supply terminals F+ and F-. If the field voltage is not correct, check one of the following:

Internally Supplied Field:

- f. Check that 3-phase is applied to terminals L1, L2 and L3 when the main contactor is closed.
- g. Check that the fuses on the power board or suppression board are healthy.
- h. Verify the Field Enable parameter is set to Enable.
- i. Is the FLD CTRL Mode parameter set to Voltage Control or Current Control?
 If set to VOLTAGE CONTROL, check the value of the FLD. VOLTS RATIO parameter. Set this to 65% to obtain 300V fields from 460V lines.
 If set to CURRENT CONTROL, check the field current calibration.
 If the field volts are at maximum, check the field continuity. (The field current may initially be lower than the rated value due to a cold field.)

Externally Supplied Field: (not available for size 1 and 2)

- a. Refer to Chapter 4 Installation, Motor Field Connections for conversion details.
- b. Check the voltage applied (externally fused) to terminals FL1 and FL2.
- c. Check the phasing of voltage applied to FL1 and FL2:
 FL1 must be connected directly or indirectly to the Red phase on main power terminal L1.
 FL2 must be connected directly or indirectly to the Yellow phase on main power terminal L2.
- d. Verify the Field Enable parameter is set to Enable.
- e. Is the FLD CTRL Mode parameter set to Voltage Control or Current Control?
 If set to Voltage Control, check the value of the FLD. Volts Ratio parameter. Set this to 65% to obtain 300V fields from 460V lines.
 If set to Current Control, check the field current calibration set-up, refer back to "Calibration".

7. Verify that the OK and STOP LEDs are On, also either the FWD or REV LED.

Power up in Remote Mode with Feedback Continued

8. Verify that C9 is +24VDC (reference to B1), and that B3 is -10VDC (reference to B1).
9. Select the Speed Feedback type.

Action	Description	Display	Comments
Press ▼	Scroll to "Configure Drive" menu.	MENU LEVEL CONFIGURE DRIVE	
Press "M" key	Access Configure Drive menu.	CONFIGURE DRIVE CONFIGURE ENABLE	
Press "M" key	Access the Configure Enable parameter.	CONFIGURE ENABLE DISABLED	
Press ▲	Enable Configure Enable.	CONFIGURE ENABLE ENABLED	All LED's are now flashing. Press "E" when done.
Press "E" key	Returns to previous menu level.	CONFIGURE DRIVE CONFIGURE ENABLE	
Press ▼	Scroll to Speed FBK Select	CONFIGURE DRIVE SPEED FBK SELECT	
Press "M" key	Access FBK select	SPEED FBK SELECT ARM VOLTS FBK	Press ▲ to change to Analog Tach, Encoder or Encoder/Analog. Press "E" when done.

10. If using a potentiometer for a setpoint, verify its operation as follows:
 - a. Use the keypad to display the value of the Diagnostics::ANIN 3 (A4).
 - b. Vary the setpoint potentiometer and observe the input voltage change on the keypad display.
 - c. Additional Setpoint Inputs may also appear at ANIN 1 (A2) and ANIN 2 (A3). Verify these if they are installed.
 - d. The sum of all the setpoints is given by the value of the Speed Setpoint parameter. This can be verified from the keypad display.
11. Verify External Current Limit settings, if used.
If using a **single** external clamp, A6 low (0V). Verify ANIN 5 (A6) is +10V or is adjustable up to +10V. If using **dual** external clamps, A6 high (+24V). Verify ANIN 5 (A6) is at +10V or is adjustable up to +10V and that ANIN 4 (A5) is at +10V.
12. Verify speed feedback device, if possible.
 - a. Analog Tachometer – The voltage at G3 (DC Tach Input) should go positive when shaft is rotated in the forward direction.
 - b. Encoder – The ENCODER parameter should give a positive reading when shaft is rotated in the forward direction. Also check the Speed Feedback parameter is reading a positive value.
13. Set Main Current Limit to 0.00% to limit the motor current.

Action	Description	Display	Comments
Press ▼	Scroll to "Setup Parameters" menu	MENU LEVEL DIAGNOSTICS	
Press "M" key	Access the Setup Parameters menus	MENU LEVEL SETUP PARAMETERS	
Press ▼	Scroll to Current Loop	SETUP PARAMETERS CURRENT LOOP	
Press "M" key	Access Current Loop parameters	CURRENT LOOP MAIN CUR LIMIT	
Press "M" key	Access Main Current Limit parameter	MAIN CURR LIMIT 90.01%	
Press ▼		MAIN CURR LIMIT 0.00%	Change the Main Current Limit to 0.00%. Press "E" when done

Power up in Remote Mode with Feedback Continued

14. Set the Configure Dive::Configure Enable parameter to disable (see step 9).
15. Save the settings.

Action	Description	Display	Comments
Start at Menu Level 1		MENU LEVEL DIAGNOSTICS	
Press ▼	Scroll to "PARAMETER SAVE" menu.	MENU LEVEL PARAMETER SAVE	
Press "M" key		PARAMETER SAVE UP TO ACTION	
Press ▲	Press ▲ to save parameters.	PARAMETER SAVE REQUESTED	Parameters are saved. Except the "Local Setpoint".
Press "E" key	Exit one level	MENU LEVEL PARAMETER SAVE	Press "E" several times to return to the top level.

16. With +24V present at terminals B8 and B9 (Program Stop and Coast Stop), do the following:
 - a. Apply the "Start/Run" command to C3. The main 3-phase contactor should pull-in and remain energized, (it may de-energize almost immediately due to the 3-phase fail alarm).
 - b. Remove the "Start/Run" command from C3. The main 3-phase contactor should drop-out and remain de-energized.

If the above sequence does not function, remove the Logic power and check start/stop sequencing and contactor wiring.

If the contactor remains energized for an extended time during this check, the controller will detect that 3-phase is not connected and switch off the contactor, and the 3-phase alarm is displayed.

The main contactor should never be operated by any means other than the drive internal controls, nor should any additional circuitry be placed around the contactor coil circuit.

Do not continue unless the Start / Stop circuits are working correctly.

If any problems were found during step 16, correct them or contact Baldor before continuing.

17. Apply 3 phase power.
18. Verify that the keypad and LED displays are still normal with no error messages.
19. Set the Speed Setpoint parameter to zero.
20. Verify that the Main CURR. Limit is set to 0.00%. View ANIN 5 (A6) parameter in the level 1 Diagnostics menu and verify it displays 0.00V.
21. Apply the Start/Run command and check that 3-phase mains is applied to Power Terminals L1, L2 and L3. Initiate "Enable" (C4) and immediately check that the correct field voltage appears between the control supply terminals F+ and F-. If the field voltage is not correct, check one of the following:

Internally Supplied Field:

- c. Check that 3-phase is applied to terminals L1, L2 and L3 when the main contactor is closed.
- d. Check that the fuses on the power board or suppression board are healthy.
- e. Verify the Field Enable parameter is set to Enable.
- f. Is the FLD CTRL Mode parameter set to Voltage Control or Current Control?
 - If set to VOLTAGE CONTROL, check the value of the FLD. VOLTS RATIO parameter. Set this to 65% to obtain 300V fields from 460V lines.
 - If set to CURRENT CONTROL, check the field current calibration.
 - If the field volts are at maximum, check the field continuity. (The field current may initially be less than the rated value due to a cold field.)

Externally Supplied Field: (not available for size 1)

- a. Refer to Chapter 4 Installation, Motor Field Connections for conversion details.
- b. Check the voltage applied (externally fused) to terminals FL1 and FL2.
- c. Check the phasing of voltage applied to FL1 and FL2:
 - FL1 must be connected directly or indirectly to the Red phase on main power terminal L1.
 - FL2 must be connected directly or indirectly to the Yellow phase on main power terminal L2.
- d. Verify the Field Enable parameter is set to Enable.

-
- e. Is the FLD CTRL Mode parameter set to Voltage Control or Current Control?
If set to Voltage Control, check the value of the FLD. Volts Ratio parameter. Set this to 65% to obtain 300V fields from 460V lines.
If set to Current Control, check the field current calibration set-up, refer to "Calibration".
 22. Verify that the OK and STOP LEDs are On, also either the FWD or REV LED. Note that all external interlocks that affect the Enable input C4 will affect the operation of the drive. Verify their connections and operation.
 23. If the Setup Parameters::Standstill::Standstill Logic parameter is Enabled, temporarily set it to Disabled.

Be ready to stop the control should the motor try to over speed.

24. Set the Speed Setpoints so that the value of the Speed Setpoint is 5%, 0.5V at setpoint input.
25. Set Configure Drive::Configure Enable parameter to Enable.
26. Set the SPEED FBK SELECT parameter to ARM VOLTS FBK (because it is hard-wired and therefore the sign will be correct).
27. Slowly increase the MAIN CURR.LIMIT parameter to a maximum of 20%. The motor should begin to rotate if all connections are made correctly. The motor speed will settle at 5% of full speed if the motor is unloaded. Check the feedback from the Tach or Encoder using the appropriate Diagnostic menu.
If the motor does not rotate, check the Current Feedback parameter to verify that current is flowing into the armature. If no current is flowing, disconnect all power and check the armature connections.
28. Stop the drive. Restore the correct Speed FBK Select parameter (if other than ARM Volts FBK) and perform the same test again.
29. If the test was successful perform a Parameter Save and continue with step 31.
If just direction of rotation is wrong, perform a or b "Reversed Connections".
 - a. **Reversed Connections** – Analog Tachometer:
Open the main contactor and switch off all supplies, then correct the connections.
 - If the motor rotates in the correct direction, reverse the tachometer connections only.
 - If the motor rotates in the wrong direction, reverse the field connections only.If the motor still runs out of control, check the tachometer and the wiring continuity.
 - b. **Reversed Connections** – Encoder
Open the main contactor.
 - If the motor rotates in the correct direction, change the Configure Drive::Encoder Sign parameter.
 - If the motor rotates in the wrong direction, disconnect all power to the Control then reverse the field connections only.
 - c. Apply power (logic power then 3 phase power) and repeat step 29.
 - d. If the drive trips on speed feedback alarm with tachometer feedback of the correct polarity, check the armature voltage calibration. Check the SPEED FBK SELECT. This could be set incorrectly allowing the drive to run open loop.
30. If 5% speed is exceeded and the motor continues to accelerate a reversed connection is implied, decrease the MAIN CURR.LIMIT parameter to zero.

Do not continue unless the control and motor are working correctly.

If any problems were found during these steps, correct them or contact Baldor before continuing.

Power up in Remote Mode with Feedback Continued

Note: Reverse Operation is possible with the Series 30 REGEN Drives only.

31. With the MAIN CURR.LIMIT parameter set to 20% or the level required to achieve rotation, set the value of the Speed Setpoint to 10%, 1.0V at setpoint input. The motor will accelerate to this speed setting.
32. Adjust the Zero Speed parameter (Ensure Standstill is Disabled).
 - a. Non-REGEN, non-reversing applications – Set the Speed Setpoint potentiometer to zero and adjust the Zero Speed Offset parameter until the shaft is just rotating then reduce level until the shaft stops.
 - b. REGEN, non-reversing applications – Set the Speed Setpoint potentiometer to zero and adjust the Zero Speed Offset parameter for minimum shaft rotation. (Series 30 REGEN Drives only).
 - c. REGEN, reversing applications – Set the Zero Speed Offset parameter to balance maximum speed in forward and reverse directions. (Series 30 REGEN Drives only).

You can set the Standstill Logic parameter to Enable if a stationary shaft is required.
33. For reversing applications set the value of the Speed Setpoint to –10% and check that motor runs in the reverse direction.
34. Gradually increase the Speed Setpoints so that the value of the Speed Setpoint (Diagnostic menu) is at maximum. Verify that shaft speed is correct. If fine adjustment is required, adjust the calibration as appropriate to the speed feedback selection:
 - a. Armature Voltage feedback has a +2/–10% trim, greater changes outside this range require a change of the calibration switches.
 - b. Analog tachometer has a +2/–10% trim, greater changes outside this range require a change of the calibration switches.
 - c. An Encoder should give an absolute rotational speed for which adjustment is unnecessary .

Adjustment for Field Weakening.

If the drive is to run with a top speed greater than the base speed, “field weakening” is used to achieve the top speed. The field must be operating in Current Control mode. Select Current Control in the Configure Drive::FLD CTRL Mode parameter.

Note: Field weakening cannot be used if you have Armature Voltage feedback selected. Adjust the maximum armature volts to the required scaled level by setting the MAX VOLTS parameter.

1. Operate the control at base speed and verify the motor volts are correct.
2. In the Level 4 FLD WEAK VARS menu, verify that field weakening is selected (FIELD WEAK ENABLE) and that the MIN FLD CURRENT parameter is set appropriately.
3. Increase the speed above the base speed. Verify that the armature volts remain constant while the field current reduces.
4. Gradually increase to maximum speed. Monitor the armature volts at maximum speed. If necessary, trim the speed feedback as previously detailed in Step 34 a, b or c.
5. Adjust the MIN FLD CURRENT parameter to the appropriate setting to limit maximum motor speed. PROCEED WITH CARE – Make Small Adjustments.
6. IR COMPENSATION (CALIBRATION function block) is also used in field weakening applications to improve dynamic response and speed holding stability. Set the IR Compensation as follows
 - a. Set Field Enable to Disabled (Field Control function block).
 - b. Start the drive with a 5% speed command and ensure the ACTUAL POS I LIMIT is 100% (diagnostic). This should stall the drive at zero speed and cause it to pass 100% current.
 - c. Monitor the BACK EMF diagnostic parameter and note the value (typically anything up to 17% is normal).
 - d. Stop the drive and enter this value into IR Compensation parameter and repeat the test to ensure that Back EMF is now zero.
 - e. Set Field Enable parameter to Enabled.
7. For reversing drives, check the maximum reverse speed. Imbalance in reversing applications can only be corrected by adjusting the ZERO SPD OFFSET parameter, which may be to the detriment of operation at Zero Setpoint.

Power up in Remote Mode with Feedback Continued

8. Reset the MAIN CURR. LIMIT to 100% to correspond to 100% full load current (FLC).

Note: The controller cannot achieve 200% current unless the CUR LIMIT/SCALER parameter is increased to 200% (from its factory setting of 100%). Until this is done, the External Current Clamp will limit the current to 100%.

- a. If the current limit is set higher (maximum 200%) and the motor runs into an overload condition, the current is automatically reduced from the current limit level down to 103% FLC (continual rating).
- b. If the motor is overloaded, the controller will reduce the current to 103% of the current calibration. (If the motor continues to rotate it may overheat and thermal protection should be provided).
- c. If the motor is overloaded and the current provided by the controller is not enough to maintain rotation, i.e. it stalls, the controller will trip out showing Stall Trip alarm, if enabled.

Autotune

Performance adjustment of the following Current Loop parameters: PROP. Gain, INT. Gain, and Discontinuous.

Initial Conditions

1. Main contactor open, i.e. no Start/Run signal at terminal C3.
2. Set the AUTOTUNE parameter to OFF.
3. Program Stop (terminal B8) and Coast Stop (terminal B9) should be high, i.e. 24V.
4. If the motor field is supplied by an external supply, remove the field manually. (If the field is internally regulated, Autotune automatically quenches the field).

Note: The shaft may require clamping for certain motors to prevent rotation >20% during the Autotune sequence. If using a permanent magnet motor, the shaft MUST be clamped.

5. Set the AUTOTUNE parameter to ON.
6. Close the main contactor, i.e. Start/Run signal to terminal C3.
7. Enable the control, terminal (C4).
8. The Autotune sequence is initiated. When complete (after approximately 10 seconds), the main contactor is opened automatically signalling the end of the sequence and the AUTOTUNE parameter is reset to OFF.
9. Save parameter settings.
10. If necessary, restore field connections and/or remove the mechanical clamp.

If autotune failed – Refer to the Manual Tuning appendix of this manual.

1. The keypad displays the message AUTOTUNE ABORTED.
The Autotune sequence is aborted causing the main contactor to drop out if any of the Initial Conditions are not present, or if the Autotune sequence times out (after 2 minutes).
2. The Operator Station displays the message AUTOTUNE ERROR.
The Autotune sequence is suspended causing the main contactor to drop out if the motor speed feedback is greater than 20% of rated speed, or the field current exceeds 6% of rated field current.

Speed Loop Adjustment You will need to adjust the Speed Loop for your application although in most cases the factory settings are acceptable. The optimum Speed Loop performance is achieved by adjusting the PROP. Gain and INT. Time CONST. parameters.

1. Produce a small step-change to the speed setpoint and observe the response on the tachometer feedback or analog output set to speed feedback.
2. Adjust PROP. Gain and INT. Time CONST. parameters until you have rapid change of speed feedback between the setpoint values with minimum overshoot.

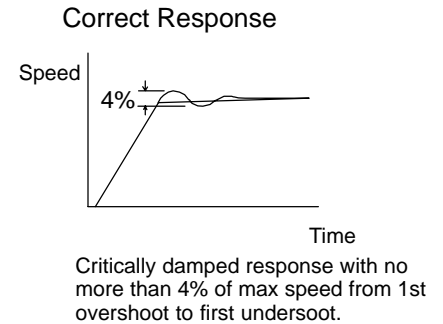
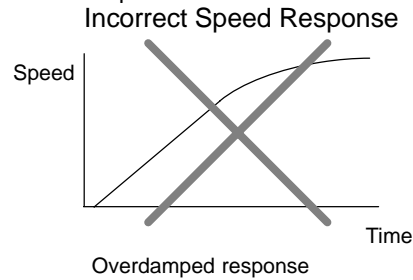
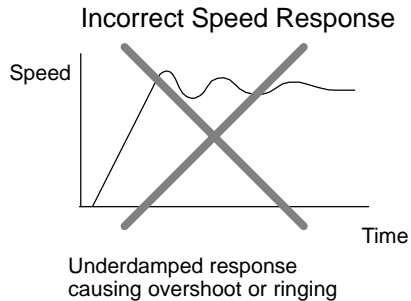

Starting and Stopping Methods

A Series 29 “non-regenerative” (2-quadrant) control coasts to a stop when the current demand reverses. A Series 30 “regenerative” (4-quadrant) control can stop faster because it uses energy from the load, i.e. reverse current is allowed to flow. The normal Stop and Program Stop are only relevant for a “regenerative” controller. The parameters Stop Time and PROG Stop Time have associated timers which initiate a Coast Stop after the timed period. The Coast Stop has direct control of the Run relay with no intervening electronics. All associated parameters can be found in the Setup Parameters::Stop Rates menu.

Terminal	Description	Function	Parameter	Priority
B8	Program Stop	Motor decelerates at Program Stop rate	PROG STOP TIME	Overrides Normal Stop
B9	Coast Stop	Motor coasts to rest		Overrides Program Stop and Normal Stop
C3	Start/Run (Normal Stop)	Motor decelerates at Normal Stop rate	STOP TIME	

Starting and Stopping Methods Continued

Normal Stop

Action – Remove 24V from Terminal C3 to stop. The motor speed is brought to zero in a time defined by the Stop Time parameter.

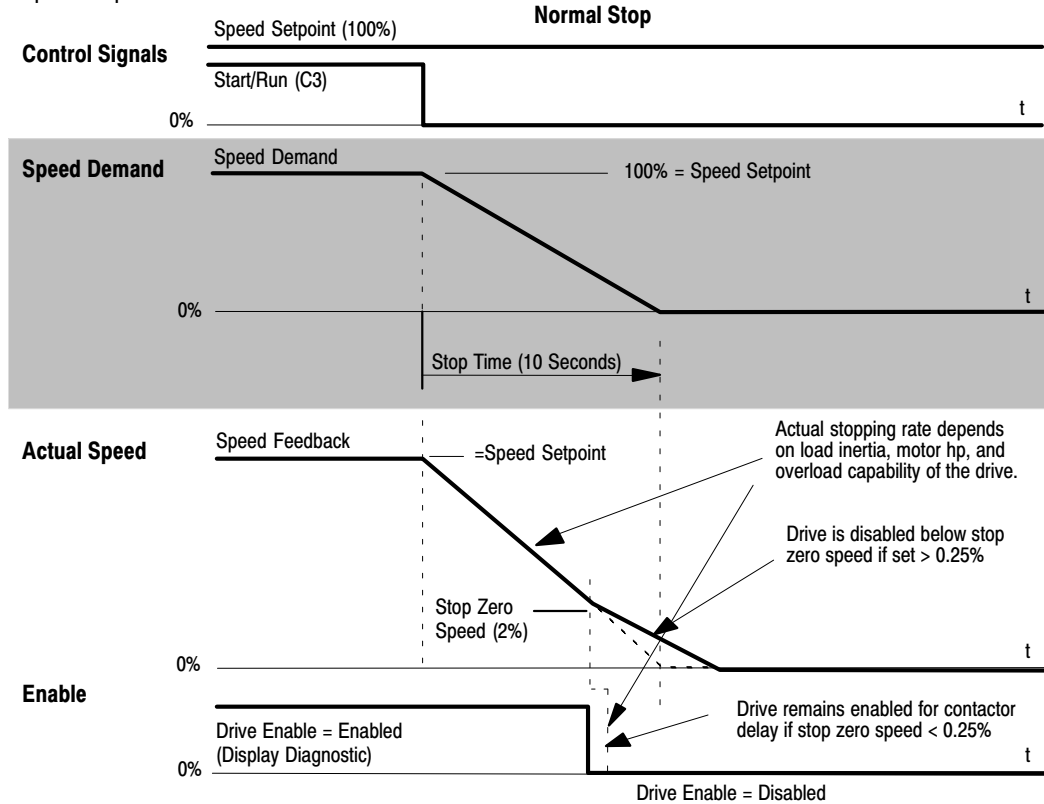

Time Out in Normal Stop

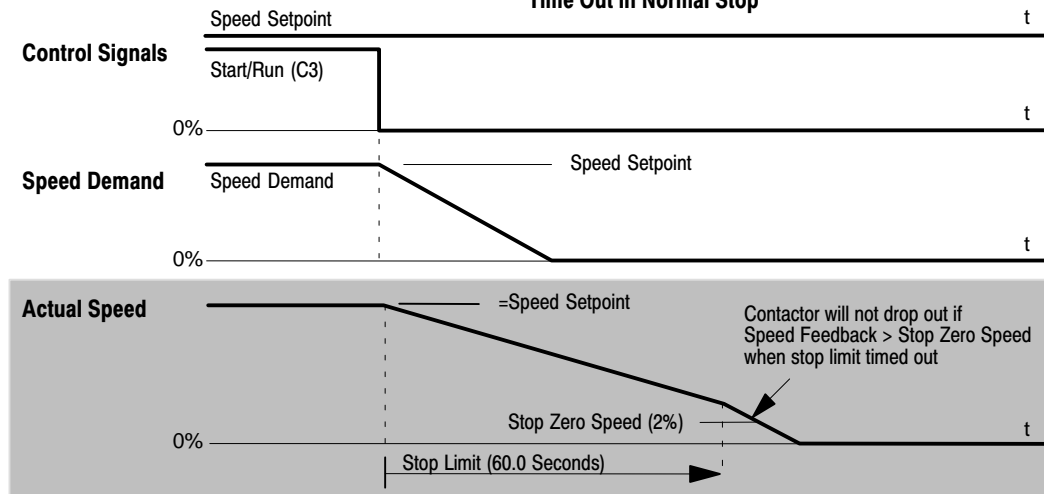

Starting and Stopping Methods Continued

Program Stop (terminal B8)

Action – Remove 24V from Terminal B8 to stop. The motor speed is brought to zero by conditions defined in PROG. Stop Time (ramp rate) and PROG. Stop I Limit parameters.

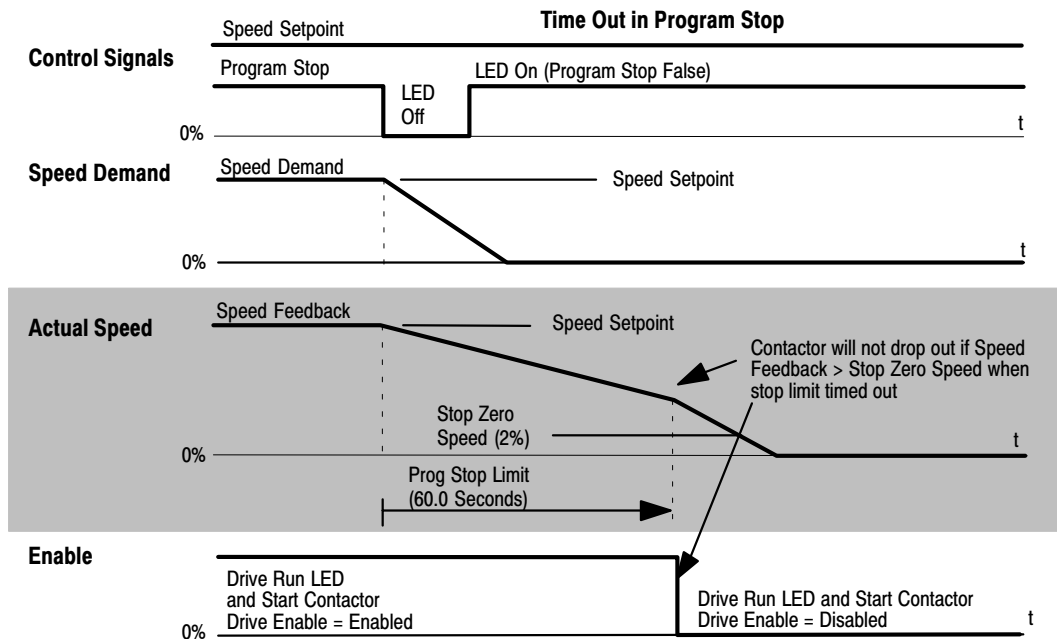
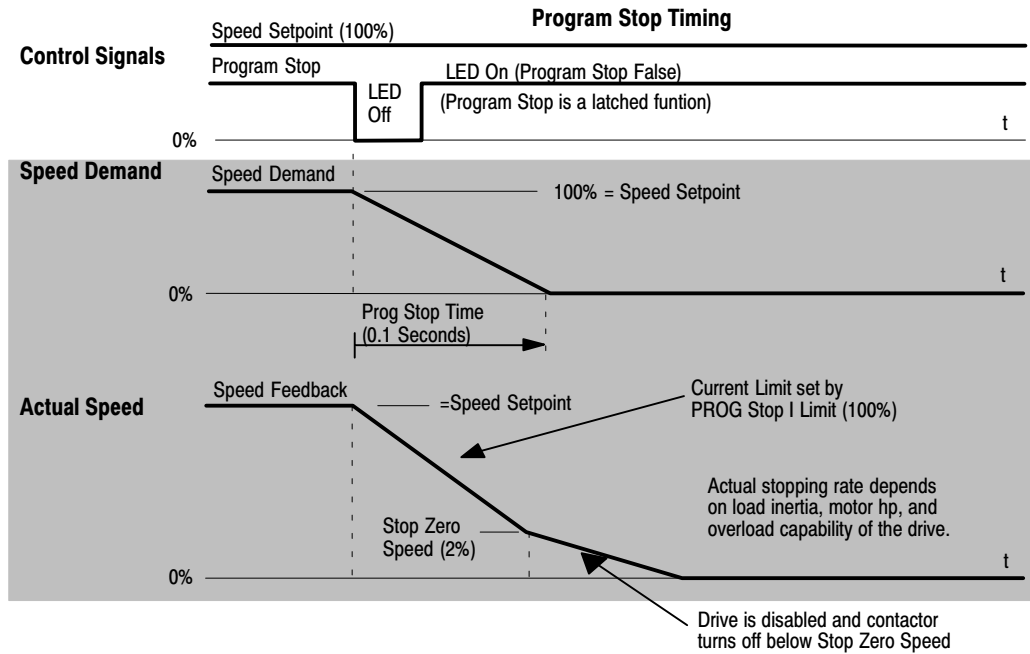

Starting and Stopping Methods Continued

Coast to Stop (terminal B9)

Action – Remove 24V from Terminal B8 to stop. The motor speed is brought to zero by conditions defined in the PROG. Stop Time (ramp rate) and PROG. Stop I Limit parameters.

The control output is automatically quenched and the contactor is opened. The motor coasts to a stop. The motor coast stop rate is dictated by the motor and load inertia – the drive does not control the motion.

Standstill

Standstill logic inhibits rotation during Zero Speed demand. If the drive speed is less than the zero speed threshold [12] and Standstill Logic [11] is enabled, the speed and current loops are disabled to prevent shaft oscillation around zero speed.

Trip Condition

When a trip condition is detected, the motor coasts to a stop. The motor coast stop rate is dictated by the motor and load inertia. The control cannot be enabled until the trip condition has been cleared and successfully reset.

Normal Starting Method

To achieve a normal start, two actions must occur:

1. Apply 24V to Terminal C4 (Enable).
2. Apply 24V to Terminal C3 (Start).

The Control will not start if there are alarms present, or if Terminals B8 (Program Stop) or B9 (Coast Stop) are low, 0V. Ensure that Program Stop and Coast Stop are valid before Start/Run is applied.

Advanced Starting Methods

Jog

1. Apply 24V to Terminal C4 (Enable).
2. Apply 24V to Terminal C6 (Jog Mode)

The Control will not start if there are alarms present. The control can be started using JOG SPEED 1, JOG SPEED 2. Also refer to the STOP RATES function block: CONTACTOR DELAY parameter is used to prevent multiple operations of the main contactor from rapid use of the Jog switch. Refer to Section 6 JOG/SLACK for more information.

Crawl

1. Apply 24V to Terminal C3 (Start).
2. Apply 24V to Terminal C6 (Jog Mode)

The Control will not start if there are alarms present. Start the control using a crawl speed, in Forward. Refer to Section 6 JOG/SLACK for more information.

Upload/Download Procedure (UDP)

Upload

This procedure will transfer the parameters from a file at the host computer to the non-volatile memory of the Control. This information is written directly to EEPROM, so **all the drive's settings are overwritten**. The procedure is as follows:

1. Verify the Control is properly connected to the PC.
2. Use a standard communications software package installed at the PC. Set the COM port for 9600, 8, 1, None. Prepare the PC communications software to send a standard ASCII text file.
3. Set the Serial Links::System Port (P3)::P3 Setup::Mode parameter to DISABLE.
4. Start the upload. Use the keypad and select Serial Links::System Port (P3)::UDP XFER (RX) and press the UP (▲) key, when instructed to start the upload.
5. When the keypad display shows RECEIVING, begin the file transfer.
6. The file ends in a `:0000001FF` which the Control uses to close the file.
7. As indicated, reset the Control by pressing the **E** key.

Download

This procedure will transfer the parameters from the Control to a file at the host computer. The procedure is as follows:

1. Verify the Control is properly connected to the PC.
2. Use a standard communications software package installed at the PC. Set the COM port for 9600, 8, 1, None. Prepare the software to receive a standard ASCII text file (Capture mode); use the file extension .UDP to differentiate it from .MMI format files.
3. Perform a PARAMETER SAVE of the Control's settings. This ensures the Dump matches the Control's settings, (the listing is of the Control's currently saved settings, i.e. held in EEPROM).
4. Set the Serial Links::System Port (P3)::P3 Setup::Mode parameter to DISABLE.
5. Start the download at the Control by selecting Serial Links::System Port (P3)::UDP XFER ((TX) on the keypad and pressing the UP (▲) key, when instructed.
6. The file ends in a Ctrl-z. With some software packages this automatically closes the downloaded file. If this is not the case, when the Control indicates it has finished and the host has stopped scrolling text, close the file at your PC. The last line should read `:0000001FF`
7. The ASCII file can now be stored like any other file on your disk drive.

1 SERIAL LINKS

2 SYSTEM PORT P3

DUMP MMI (TX)
UDP XFER (RX)
UDP XFER (TX)

DUMP Procedure This procedure will transfer the control's settings in a text format that is clear and easy to read.

1. Verify the Control is properly connected to the PC.
2. Use a standard communications software package installed at the PC. Set the COM port for 9600, 8, 1, None. Prepare the PC communications software to receive a standard ASCII text file (Capture mode); use the file extension .UDP to differentiate it from .MMI format files.
3. Perform a PARAMETER SAVE of the Control's settings. This ensures the Dump matches the Control's settings, (the listing is of the saved settings held in EEPROM).
4. Set the Serial Links::System Port (P3)::P3 Setup::Mode parameter to DISABLE.
5. Start downloading on the Control by selecting Serial Links::System Port (P3)::Dump MMI (TX) on the keypad and pressing the UP (▲) key, when instructed.
6. The file ends in a Ctrl-z. With some packages this automatically closes the file but if this is not the case, when the Control says it has finished and the host has stopped scrolling text, close the file.
7. The ASCII file can now be stored like any other file on your disk drive.

The following partial file was produced by performing a MMI DUMP (TX) to a PC, as described above. The file shows the Control default settings.

When printing this file, it is useful to select a Mono spaced font, such as Courier, so the text columns line-up. Note that in the list shown, 'menus' have been highlighted (bold) to make the list easier to use.

```
DIGITAL DC DRIVE
ISSUE:X.X
..MENU LEVEL
....DIAGNOSTICS
.....SPEED DEMAND      [89 ] =      0.00 %
.....SPEED FEEDBACK    [207 ] =     0.00 %
.....SPEED ERROR       [297 ] =     0.00 %
.....CURRENT DEMAND    [299 ] =     0.00 %
.....CURRENT FEEDBACK [298 ] =     0.00 %
.....POS. I CLAMP      [87 ] =       0.0 %
.....NEG. I CLAMP      [88 ] =       0.0 %
.....ACTUAL POS I LIM  [67 ] =       0.0 %
.....ACTUAL NEG I LIM  [61 ] =       0.0 %
.....INVERSE TIME O/P [203 ] =    200.00 %
.....AT CURRENT LIMIT [42 ] = FALSE
.....AT ZERO SPEED     [77 ] = TRUE
.....AT ZERO SETPOINT [78 ] = TRUE
.....AT STANDSTILL     [79 ] = TRUE
.....STALL TRIP        [112 ] = OK
.....RAMPING           [113 ] = FALSE
.....PROGRAM STOP      [80 ] = TRUE
.....DRIVE START        [82 ] = OFF
.....DRIVE ENABLE       [84 ] = DISABLED
.....OPERATING MODE     [212 ] = STOP
.....FIELD ENABLE       [169 ] = DISABLED
.....FIELD DEMAND       [183 ] =     0.00 %
```

Example only

Section 6 Programming

Overview

The shipping configuration allows the user to start up and run a DC motor in simple speed control. The flexibility is having the ability to change configuration and to tune the control for optimum performance. The parameters most frequently adjusted for tuning and performance are in the Setup Parameters menu. They are categorized by submenu within the overall software block diagram.

This chapter describes each of these parameters.

You can set the parameter values within the Setup Parameters submenu (keypad) or by using a Workbench D (see Manual MN794). You can also configure the drive or connect and reconnect signals between drive function blocks and I/O terminals from the keypad or Workbench D. Parameters in this section are in the order of the keypad submenu.

The drive's parameters and function block inputs and outputs are defined as either a percentage if they are continuous, or as boolean value (1 or 0) if they are discrete. Depending on how the drive is configured, these parameters can represent physical entities such as motor speed or current. Connecting inputs or outputs to software function blocks or to real world signals defines what the function block inputs or outputs represent. For example, the output (Destination Tag) from Raise/Lower can represent current demand if sent to the current loop or a speed setpoint if sent to the speed loop.

Menu System

The menu system is divided into nine major selections, shown in Table 6-1. Each selection has a structure of menus (Figure 6-1). At the keypad, press "M" to access the menus. Then press the ▲ or ▼ key to scroll through the menus. Refer to section 7 for more information on the keypad and menus.

Table 6-1 Keypad Display of the Main Menus

Action	Description	Display	Comments
Apply Power	Keypad Display shows this opening message.	FORWARD REF: 0.00%	
Press "PROG" key		BALDOR DC DRIVE DC 4Q 15A	
Press "M"		DC 4Q 15A MENU LEVEL	
Press "M"	Access the menus.	MENU LEVEL DIAGNOSTICS	Press "M" key to access Diagnostic menus.
Press ▼	Scroll to next menu.	MENU LEVEL SETUP PARAMETERS	Press "M" key to access Setup Parameters menus.
Press ▼	Scroll to next menu.	MENU LEVEL PASSWORD	Press "M" key to access Password menus.
Press ▼	Scroll to next menu.	MENU LEVEL ALARM STATUS	Press "M" key to access Alarm Status menus.
Press ▼	Scroll to next menu.	MENU LEVEL MENUS	Press "M" key to access Menus.
Press ▼	Scroll to next menu.	MENU LEVEL PARAMETER SAVE	
Press ▼	Scroll to next menu.	MENU LEVEL SERIAL LINKS	Press "M" key to access Serial Links menus.
Press ▼	Scroll to next menu.	MENU LEVEL SYSTEM	Press "M" key to access System menus.
Press ▼	Scroll to next menu.	MENU LEVEL CONFIGURE DRIVE	Press "M" key to access Configure Drive menus.

Menu Navigation

Remember, press "E" to return to the previous level of menus. Press "M" to enter the next level of menus. Press the ▲ or ▼ key to go to the previous or next menu item at the same level.

Parameter Types

Each drive parameter is associated with a unique address, or “tag.” When “connecting” any parameter to drive inputs, outputs, or links, this tag is designated as the source or destination address. These drive parameters are listed by tag number, parameter name and menu group name in the appendix of this manual. There are only two types of parameters: logic or value.

Logic

Logic parameters are boolean – or either On (1) or Off (0). The keypad displays logic signals in a variety of ways, each associated with the On and Off state like Enabled/ Disabled, True/False, Positive/Negative, or Even/Odd.

Value

Value parameters have a range of values depending on its function. The display is formatted appropriately (for example in percent). In all cases these values will not exceed five digits. For example, 100.00% is handled by the controller as 10000 and 30.00 as 3000. Other value parameters can be HEX numbers, ordinals, and lists. The ranges of these values depend on the parameter type.

Configuration Procedure

Before making any configuration changes with the keypad, you must set Configure Enable to Enabled. After completing the changes, set Configure Enable to Disabled to accept the changes then select “Parameter Save” to save to memory the changes you have made.

Note: Configuration changes are not allowed while running and will trip out on the alarm failure Configuration Enabled if the drive is started while Configure Enable is Enabled.

Make configuration changes from the keypad as follows:

1. Set parameter System::Configure I/O::Configure Enable to Enabled.
2. Find the input or output you want to change.
3. Change the source and/or destination tag as required.
4. Set the or analog or digital I/O parameter calibrations as needed.
5. Set parameter Configure Enable to Disabled.
6. Save Parameters.

Figure 6-1

Menu Levels

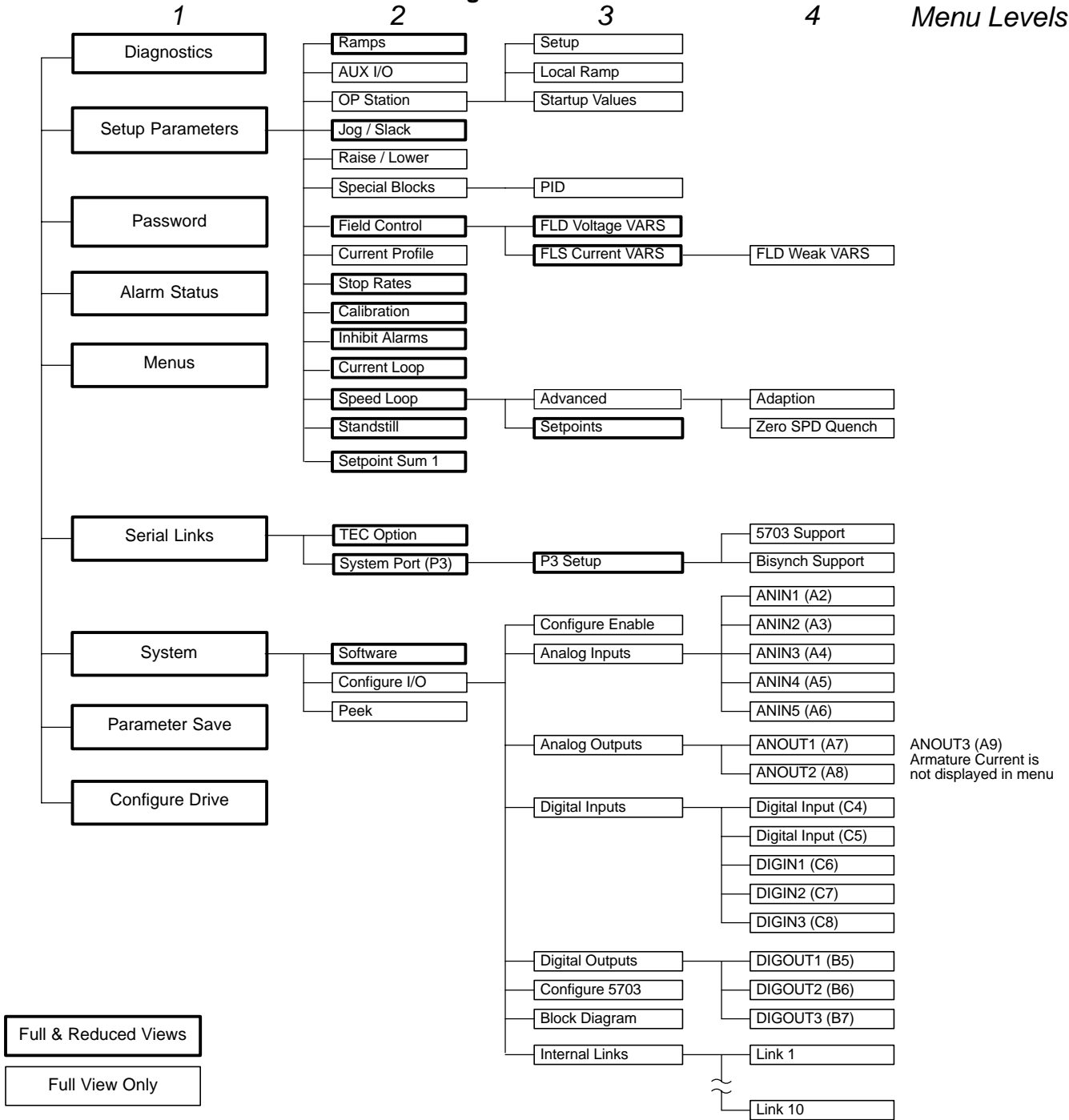

Parameter Descriptions

Analog Inputs

Five analog input blocks are used to scale and clamp the inputs for terminals A2 through A6. Analog input 1 is the 0–20mA or 4–20mA input. Analog input 2 is the main speed loop input (without Accel/Decel ramps). Analog input 3 is Speed setpoint no. 3. Analog input 4 is the negative current clamp; this is only active if bipolar clamps are enabled; ANIN 5 – Main current limit (or positive current clamp if bipolar clamps are enabled). ANIN 4 is then the Negative current clamp input).

- 1 SYSTEM
- 2 CONFIGURE I/O
- 3 ANALOG INPUTS
- 4 ANIN 1 (A2)
- 4 ANIN 2 (A3)
- 4 ANIN 3 (A4)
- 4 ANIN 4 (A5)
- 4 ANIN 5 (A6)

Calibration
MAX Value
MIN Value
Destination Tag *

* ANIN 2 (A3) Notes:

1. ANIN 2 output [493] has two **permanent connections**:
 - a. SETUP PARAMETERS:: SPEED LOOP:: SETPOINTS:: RATIO 2 (A3) input and
 - b. SETUP PARAMETER:: CURRENT LOOP:: I DMD. ISOLATE switch.

If you do not want ANIN 2 output [493] to be in the Speed or Current Loops, set RATIO 2 (A3) [7] to zero, and set I DMD. ISOLATE [119] to DISABLED.
2. ANIN 2 (A3) is a direct input into the speed loop/current loop and is scanned synchronously with the current loop (typically every 3.33ms rather than every 7ms). Therefore ANIN 2 should be used for any signal whose response is critical.
3. Other tags can be connected to ANIN 2 output [493] for access to the calibrated final value of ANIN 2.

Diagnostic connection (tag accessible from the Diagnostic Menu) allows monitoring of the raw analog input signals from within the Diagnostics parameter block.

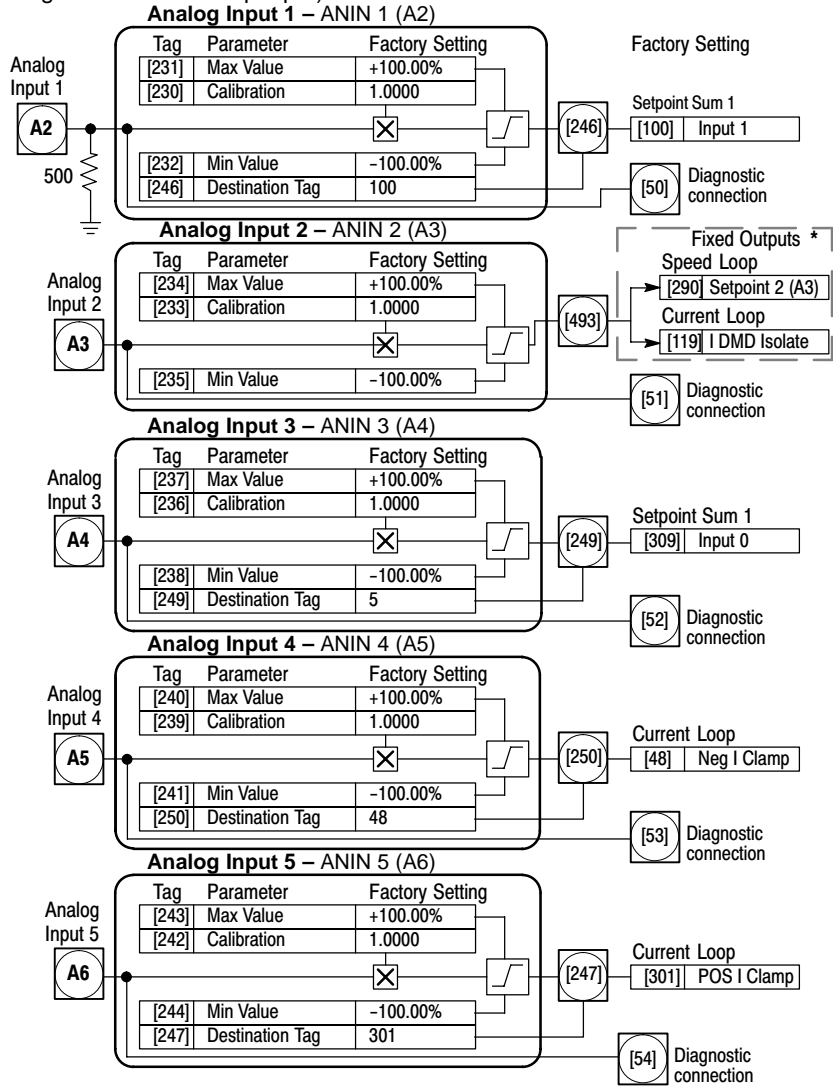

Keypad Menu: System::Configure I/O::Analog Inputs::Block Title

Block Title	Parameter	Description
ANIN1 (A2)	Calibration	CALIBRATION The analog input scaling ratio (gain factor).
ANIN2 (A3)	MAX Value	MAX VALUE The maximum value of the scaled analog input (max voltage clamp).
ANIN3 (A4)	MIN Value	MIN VALUE The minimum value of the scaled analog input (min voltage clamp).
ANIN4 (A5)	Destination Tag	DESTINATION TAG [Output], (except ANIN 2) The destination Tag No. to which the scaled analog input value is connected. The destination of Output [493] ANIN2 is fixed. It is a calibrated scaled value.
ANIN5 (A6)	Destination Tag	DESTINATION TAG [Output], (except ANIN 2) The destination Tag No. to which the scaled analog input value is connected. The destination of Output [493] ANIN2 is fixed. It is a calibrated scaled value.

Analog Inputs Continued

Input	Description
Analog input 1 Terminal (A2)	Used as a unipolar 0–20mA ramped speed command channel. Output [246] is connected to Setpoint Sum 1, Input 1. To use 4–20mA requires setting the Min value to 25%, the Max Value to 125% and the Setpoint Sum1, Input 2 to (–)25%. These settings provide the proper scaling and offset to set 4mA to zero command. An input value less than 4mA results in a Min Value of 25% being summed with the (–)25% at the Setpoint Sum 1 summing junction. Output of Setpoint Sum 1 block is connected to the ramp input [5] of the Ramps block. Ramp invert [620] is controlled by C5, the reverse input. When C5 is closed, the ramp is inverted and the rotation direction is changed. This allows an Accel and Decel Rate limited command signal in either direction. Output of Ramps block is connected to Setpoint 1 of the Speed Loop block.
Analog input 2 Terminal (A3)	No Accel / Decel Ramp is provided for this input. Used as a non–ramped speed or torque command channel. Output [493] is connected to Speed Loop Setpoint 2 and Current Loop Input. Closing terminal C8 (Digital Input 3) selects Torque Command Mode (enables IDMD Isolate input of the Current Loop). Opening terminal C8 (Digital Input 3) selects Speed Command Mode by (disables the IDMD Isolate input of the Current Loop). In all cases this analog command channel bypasses the Ramps Block.
Analog input 3 Terminal (A4)	Used as a ramped $\pm 10V$ speed command channel. Output [249] is connected to Setpoint Sum 1, Input 0. Output of Setpoint Sum 1 block is connected to the ramp input [5] of the Ramps block. Ramp invert [620] is controlled by C5, the reverse input. When C5 is closed, the ramp is inverted and the rotation direction is changed. This allows an Accel and Decel Rate limited command signal in either direction. Output of Ramps block is connected to Setpoint 1 of the Speed Loop block. Various voltage range, and bipolar or unipolar commands can be accepted by adjusting Calibration, Max Value, and Min Value parameters of Analog Input 3.
Analog input 4 Terminal (A5)	Not active if Bipolar Clamps parameter [90] is false. Used as an External Reverse (Negative) Current Limit if Bipolar Clamps parameter [90] is true.
Analog input 5 Terminal (A6)	Used as an External (Forward and Reverse) Current Limit. A hardwire jumper is supplied from terminal B3 (+10V Ref) to A5 to allow full rated 150% current. Used as an External Forward Current Limit if Bipolar Clamps parameter is set to Enabled.
	When [90]=False, Analog IN 5 provides a bipolar current limit.
	When [90]=True, Analog IN 5 is the positive current limit (Analog IN 4 is the negative current limit).

Analog Inputs – Inputs can be connected to any writable parameter. The read/write status of each parameter is listed in Appendix B. (RO is read only and RW is read/write.)

Example – Using analog input 1 as a 4–20mA input.

The parameter values for Analog Input 1 can be changed at the keypad. The 4–20mA source is connected to A2. Apply AC power to the control and observe the keypad display. The 500 ohm resistor at the A2 input converts a 0–20mA input current to 0 to 10 volt signal. So a 4–20mA input must be scaled so 4mA = 0VDC and 20mA = 10VDC. Analog Input 1 output terminal [246] is connected to Setpoint Sum 1, Input 1. 4–20mA requires the Min value = 25%, Max Value = 125% and setting Setpoint Sum1, Input 2 to (–)25%. These settings provide the proper scaling and offset to set 4mA to zero command. Any input less than 4mA will result in a Min Value of 25% being added to (–)25% at the Setpoint Sum 1 summing junction.

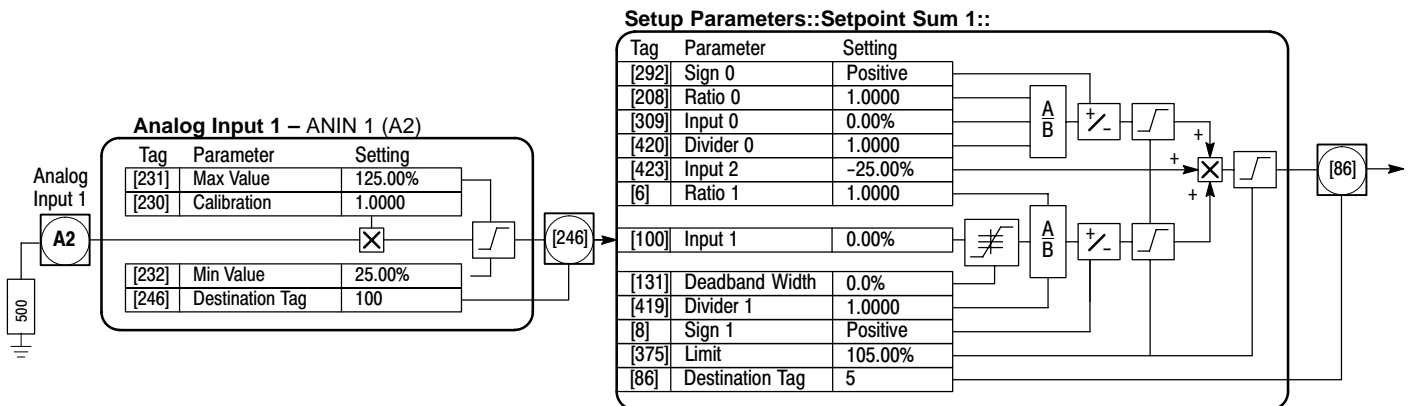

4–20mA Direction Change

Output of Setpoint Sum 1 block is connected to the ramp input [5] of the Ramps block. Ramp invert [620] is controlled by C5, the reverse input. When C5 is closed, the ramp is inverted and the rotation direction is changed. This allows an Accel and Decel Rate limited command signal in either direction. Output of Ramps block is connected to Setpoint 1 of the Speed Loop block.

Analog Outputs Three Analog Outputs are available, A7, A8 and A9. A7 and A8 can be configured and the source of an analog output signal can be read from any parameter. It is important to remember that other parameters do not “send” signals to the output terminal. An output terminal “retrieves” the signal from the parameter described by its Source Tag parameter. A9 is the armature current output and cannot be changed.

- 1 SYSTEM
- 2 CONFIGURE I/O
- 3 ANALOG OUTPUTS
- 4 ANOUT 1 (A7)

% TO GET 10V
MODULUS
OFFSET
SOURCE TAG

Speed Loop

[62] Speed Feedback

ANOUT 1 (A7)

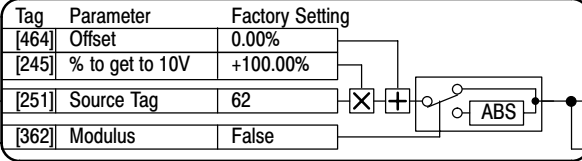

A7 Analog Output 1
[55] Diagnostic connection

Description

+10V= Full speed setpoint forward.
-10V = Full speed setpoint reverse.

Setpoints

[63] Speed Setpoint

ANOUT 2 (A8)

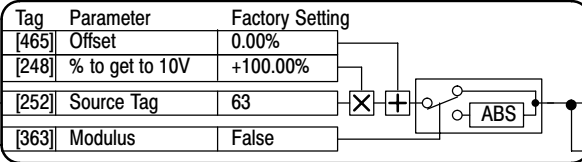

A8 Analog Output 2
[56] Diagnostic connection

+10V= Full speed setpoint forward.
-10V = Full speed setpoint reverse.

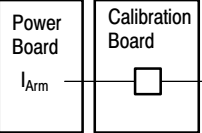

ANOUT 3 (A9)

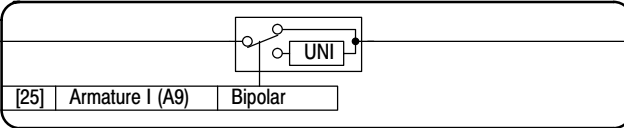

A9 Analog Output 3
Arm I Fbk

Bipolar Mode

+10V= 200% output current forward.
-10V = 200% output current reverse.
Unipolar Mode
+10V= 200% output current.

Parameter Descriptions

INPUT

(SOURCE TAG)

The source Tag No. of the output value.

Range: 0 to 549

% TO GET 10V (10V CAL)

This value is based on the range of the source. It can be set positive or negative to set the sign of the output and scale the input to give a 10V output.

Range: -300.00 to 300.00 %

OFFSET

Offset value added to the input value after the scaler and before the modulus.

Range: -100.00 to 100.00 %

MODULUS

Modulus determines whether the output is bipolar or unipolar.

False allows the input to pass through to the output (bipolar).

When TRUE, the output is unipolar (will not go negative). Negative input values are made positive (absolute value).

Range: 0 : False
1 : True

ANOUT 1 & 2 (Read in Diagnostics Parameters)

ANOUT 1 (A7)=scaled speed feedback. ANOUT 2 (A8)= Total speed setpoint.

Range: xxx.xx Volts (h)

Armature I (A9) (Armature Current only at Analog Output 3)

Bipolar provides ±10V signal that represents armature current.

Range: 0 : Bipolar
1 : Unipolar

Unipolar provides 0 to 10V signal that represents armature current.

Analog Outputs Continued

Example 1 – Read the field current feedback using Analog Output 1.

The tag number for the field current feedback parameter is 300.

1. Set CONFIGURE I/O::CONFIGURE ENABLE to Enable.
2. Set ANALOG OUTPUTS::ANOUT 1 (A7):: SOURCE TAG to 300.
3. Set ANALOG OUTPUTS::ANOUT 1 (A7):: % TO GET 10 VDC to 100% (factory setting).
4. Set SETUP PARAMETERS::CALIBRATION::ARMATURE I (A9) to Bipolar (factory setting).
5. Reset CONFIGURE I/O::CONFIGURE ENABLE to Disable.

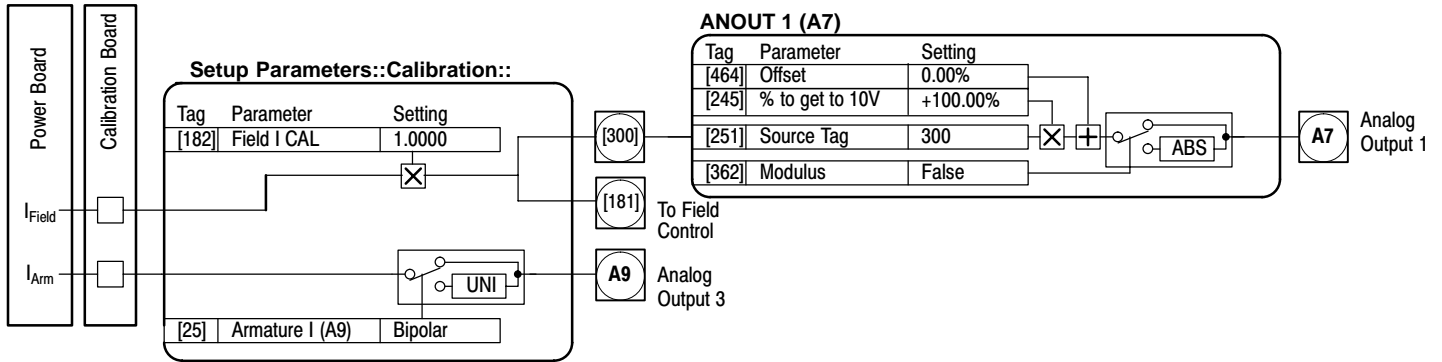

Example 2 – Connect the serial link to Analog Output 1.

Allows analog output 1 to read values written by an external device to PNO 58 (ASCII 3A) which is AUX I/O Analog Out 1. The tag number for the AUX I/O::ANOUT 1 parameter is 128.

1. Set CONFIGURE I/O::CONFIGURE ENABLE to Enable.
2. Set ANALOG OUTPUTS::ANOUT 1 (A7):: SOURCE TAG to 128.
3. Set ANALOG OUTPUTS::ANOUT 1 (A7):: % TO GET 10V to 100% (factory setting).
4. Reset CONFIGURE I/O::CONFIGURE ENABLE to Disable.

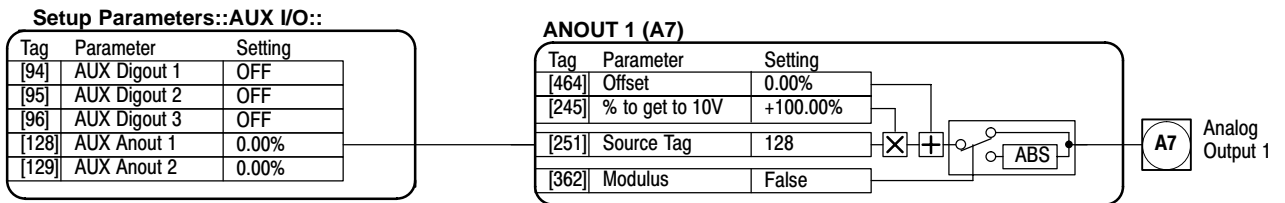

Example 3 – Connect the current demand to Analog Output 2.

The tag number for the current demand parameter is 66.

1. Set CONFIGURE I/O::CONFIGURE ENABLE to Enable.
2. Set ANALOG OUTPUTS::ANOUT 2 (A8):: SOURCE TAG to 66.
3. Set ANALOG OUTPUTS::ANOUT 2 (A8):: % TO GET 10V to 200%.
4. Reset CONFIGURE I/O::CONFIGURE ENABLE to Disable.

Setting % TO GET 10V at 200% results in 5 volts output when current feedback is at 100%.

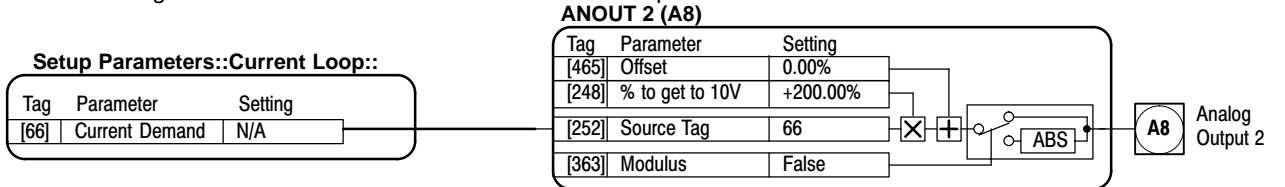

AUX I/O

The auxiliary I/O parameters allow an external computer (or PLC) to control the Start, Jog and Enable terminals. Start, Enable and Jog digital input terminals C3, C4, C6 and C7 respectively connect directly to the AUX I/O block. Output signals are then sent to the drive start and drive enable logic and the Jog/Slack function block.

1 SETUP PARAMETERS

2 AUX I/O

AUX Start
 AUX Jog
 AUX Enable
 AUX Digout 1
 AUX Digout 2
 AUX Digout 3
 ANOUT 1
 ANOUT 2
 Jog/Slack
 REM. SEQ. Enable
 REM Sequence
 SEQ Status
 Enable

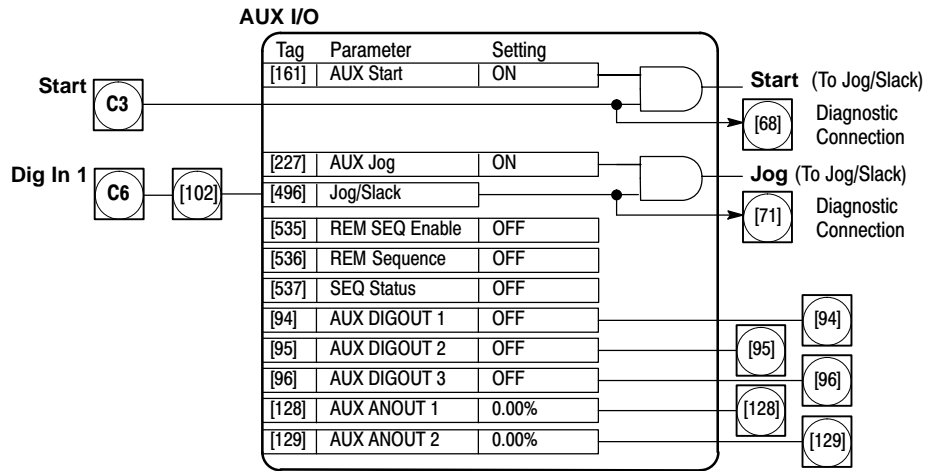

Parameter Descriptions

Start (C3) (Read in Diagnostics Parameters)

Start/Run terminal. ON initiates a start/run forward sequence. Off commands Stop and decels at Stop Rates, Stop Time setting.

Range: 0 : OFF
 1 : ON

Jog (C6 is set in Digital Input Parameters)

Jog/Takeup slack terminal. If C6 = On and C7 is Off, motor is commanded to run forward at Jog Speed 1. If C6 is On and C7 is On, motor is commanded to run forward at active speed setpoint plus Jog/Slack, Take Up 1 speed. Various Jog or Slack takeup functions are commanded depending on the various settings of terminals C6, C7 and parameter Jog/Slack, Mode.

Range: 0 : OFF
 1 : ON

SEQ Status

A status word that groups important system flags together for use by remote device over a network. (Refer to "Remote Sequence").

Range: 0x0000 to 0xFFFF

AUX Start

Software Start/Run command.

Range: 0 : OFF
 1 : ON

AUX Jog

Software Jog command.

Range: 0 : OFF
 1 : ON

AUX Enable

Software Enable command.

Range: 0 : OFF
 1 : ON

AUX DIGOUT 1

Software digital output 1.

Range: 0 : OFF
 1 : ON

AUX DIGOUT 2

Software digital output 2.

Range: 0 : OFF
 1 : ON

AUX DIGOUT 3

Software digital output 3.

Range: 0 : OFF
 1 : ON

ANOUT 1

Software analog output 1.

Range: -100.00 to 100.00 %

ANOUT 2

Software analog output 2.

Range: -100.00 to 100.00 %

REM. Sequence (REM.SEQUENCE)

A control word that allows the device to be operated remotely. REM. SEQ. ENABLE must be True to enable this function. (Refer to "Remote Sequence").

Range: 0x0000 to 0xFFFF

REM. SEQ. Enable (REM.SEQ.ENABLE)

False disables REM.SEQUENCE, On enables REM.SEQUENCE.

Range: 0 : OFF
 1 : ON

AUX I/O Continued

Functional Description

The external device sends its signal directly to the required tag (PNO). In the case of auxiliary digital inputs AUX Start, AUX Jog and AUX Enable, the overall input will be the result of the “AND” gating of the normal terminal signal with the auxiliary signal from an external computer or PLC.

The remaining auxiliary outputs allow external computers to directly control the output terminals. These connections are set in SYSTEM::CONFIGURE I/O.

ANOUT 1 & 2 can also be used as a “jumper” for connecting inputs to outputs. Example: Use ANOUT1 [128] to connect Analog Input 1 (A2) [246] directly to Analog Output 1 (A7) [251].



Remote Sequence Tag 536, Mnemonic “ow”, Factory setting = 0x0000

Reserved bits are undefined when read and should be set Zero when written.

Bit Number	Mask	Name	Comment
0 (lsb)	0x0001	Remote Enable	
1	0x0002	Remote Start	
2	0x0004	Remote Jog	
3	0x0008	Remote Jog Mode	Selects Jog Speed
4	0x0010	Reserved	
5	0x0020	Reserved	
6	0x0040	Reserved	
7	0x0080	Reserved	
8	0x0100	Remote Alarm Ack	Alarm Acknowledge
9	0x0200	Remote/Remote Trip	Remote Trip (High for OK)
10	0x0400	Reserved	
11	0x0800	Reserved	
12	0x1000	Reserved	
13	0x2000	Reserved	
14	0x4000	Reserved	
15	0x8000	Reserved	

SEQ Status Tag 537, Mnemonic “ox” (Read Only), Factory setting = OFF (Reserved bits are undefined when read.)

Bit Number	Mask	Name	Comment
0 (lsb)	0x0001	Coast Stop	Coast Stop demanded
1	0x0002	Program Stop	Program (Fast) Stop demanded
2	0x0004	Disable	Enable demanded
3	0x0008	Run	Drive Start demanded
4	0x0010	Jog	Drive Jog demanded
5	0x0020	Reserved	Undefined
6	0x0040	Alarm	Unacknowledged alarm (Health Store != 0)
7	0x0080	Reserved	Undefined
8	0x0100	Running	Contactor in and drive ready to be enabled
9	0x0200	Enabled	Drive is enabled.
10	0x0400	Zero Speed	Zero speed Output TAG 17
11	0x0800	Healthy Output	Healthy Output TAG 12
12	0x1000	Ready	Ready Output TAG 559
13	0x2000	Reserved	Undefined
14	0x4000	Reserved	Undefined
15	0x8000	Reserved	Undefined

AUX I/O Continued
Example Bit Patterns

Sequence Status	Comment
0001 1011 0000 1011	Running
0000 0100 0100 1011	Tripped, Run High
0000 0100 0100 0111	Tripped, Run Low, Enable Low
0000 1100 0100 0111	Trip Acknowledged, Healthy o/p TRUE Alarm stays high until drive is restarted.

Example Serial commands using EI-ASCII – REM. SEQUENCE

Tag 536, Mnemonic “ow”, Factory setting = 0x0C07

	Remote Trip	Alarm Ack	Jog Mode	Jog	Start	Enable	Command
Start Drive	1	0	X	0	1	1	ow>0203
Stop Drive	1	0	X	0	0	1	ow>0201
Disable Drive	1	0	X	X	X	0	ow>0200
Jog Setpoint 1	1	0	0	1	0	1	ow>0205
Jog Setpoint 2	1	0	1	1	0	1	ow>020C
Remote Trip	0	0	X	X	X	X	ow>0000
Reset Alarm a)	1	1	0	0	0	0	ow>0300
Reset Alarm b)							Healthy Output Bit 11
Reset Alarm c)	1	0	50	0	0	0	ow>0200

- Drive Enable** To Enable the drive in remote mode the following parameters must be TRUE: REM.SEQ.ENABLE[535] and REM SEQUENCE [536] BIT 1.
- Drive Start** To Start the drive in remote mode the following parameters must be TRUE: REM.SEQ.ENABLE[535] and REM SEQUENCE [536] BIT 0.
- Drive Jog** To Jog the drive in remote mode the following parameters must be TRUE: REM.SEQ.ENABLE[535] and REM SEQUENCE [536] BIT 3.
- Jog Mode** To select the jog setpoint in remote mode the following parameters must be TRUE:REM.SEQ.ENABLE[535] and REM SEQUENCE [536] BIT 4.
- ACK Alarm** To Acknowledge an alarm the following parameter must be TRUE:REM SEQUENCE [536] BIT 8.
Note: If remote sequencing is not enabled then REM SEQUENCE [536] BIT 8 is forced TRUE.
- Remote Trip Alarm** The Remote trip alarm is designed to signal a network fault to the drive. When using the Profibus interface, all outputs are set to zero on link fail. If one of the outputs is REM SEQUENCE [536] the drive will trip after a delay specified by REM TRIP DELAY (541). The Drive will then need a low – > high transition on ACK Alarm and Start before the drive may run again.

REM TRIP INHIBIT [540]	REM TRIP DELAY [541]	REMOTE TRIP [542]
Disable remote trip.	Delay before trip becomes active after bit being cleared.	Status of the Remote trip alarm, OK, Warning (Remote Seq Bit 9 FALSE and delay not expired), Active (Trip active, timer expired and remote not inhibited).

Block Diagram The Block Diagram parameters make the connections of input and output tags for the blocks identified on the block diagrams of Appendix C. These connections are only executed when the destinations are connected to a non-zero tag. If a function is not required, set its destination tag to zero. A tag=0 causes the processor to ignore the function and reduces processor loading.

Note: Only the connections are described here. For information about an input or output, refer to the description of that block described in this section.

1

2

3 [Block Name] I/O Signal Name

		Factory	
[Tag]	Value	Description	
[Raise/Lower] Output Destination	[260] 0	Raise/Lower] Output Destination	
[Ramps] Ramp Output Destination	[293] 291	[Ramps] Ramp Output to Setpoint 3 of Speed Loop block.	
[Setpoint Sum 1] SPT Sum Destination	[294] 289	[Setpoint Sum 1] SPT Sum to Setpoint 1 of Speed Loop block.	
[PID] PID Output Destination	[400] 0	[PID] PID Output Destination	
[Current Loop] POS I Clamp Source	[435] 0	[Current Loop] POS I Clamp Source	
[Current Loop] NEG I Clamp Source	[436] 0	[Current Loop] NEG I Clamp Source	

Parameter Descriptions

- [Raise/Lower] Output Destination** Range: 0 to 549
Connects the output of the Raise/Lower block to its destination tag.
- [Ramps] Ramp Output Destination** Range: 0 to 549
Connects the Ramp Output of the Ramps block to its destination tag.
- [Setpoint Sum 1] SPT Sum Destination** Range: 0 to 549
Connects the SPT Sum Output of the Setpoint Sum 1 block to its destination tag.
- [PID] PID Output Destination** Range: 0 to 549
Connects the PID Output of the PID block to its destination tag.
- [Current Loop] POS I Clamp Source** Range: 0 to 549
Connects the POS 1 Clamp input of the Current Loop block to its source tag.
- [Current Loop] NEG I Clamp Source** Range: 0 to 549
Connects the NEG 1 Clamp input of the Current Loop block to its source tag.

Calibration

This block contains parameters specific to the motor.

Note: Control operation is suspended and all Keypad LEDs will flash while the Configure Enable = Enabled.

1 SETUP PARAMETERS

2 CALIBRATION

Configure Enable
NOM Motor Volts
Armature Current
Field Current
Armature V CAL
IR Compensation
Encoder RPM
Encoder Lines
Analog TACH CAL
Zero SPD Offset
Armature I (A9)
SPDFBK Alarm Level
Stall Threshold
Stall Trip Delay
REM Trip Delay
Overspeed Level
Field I CAL

These parameters can also be set in the Level 1 "Configure Drive" menu.

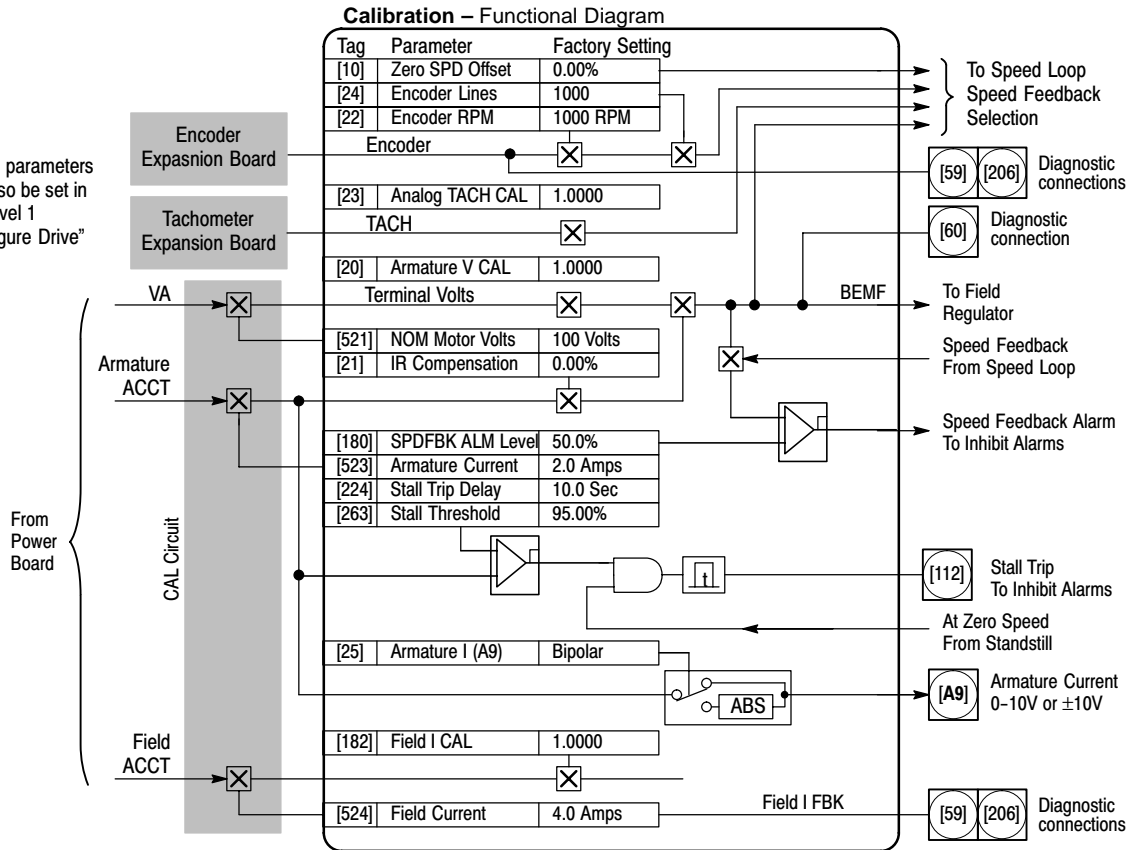

Parameter Descriptions

Terminal Volts (Read in Diagnostics Parameters)
Scaled terminal voltage.

Range: xxx.xx % (h)

Tach Input (B2) (Read in Diagnostics Parameters)
Scaled analog tachogenerator feedback.

Range: xxx.xx % (h)

Encoder (Read in Diagnostics Parameters)
Encoder speed feedback in RPM

Range: xxxxx RPM

Back EMF (Read in Diagnostics Parameters)
Calculated motor back EMF including IR compensation.

Range: xxx.xx % (h)

Field I Feedback (Read in Diagnostics Parameters)
Scaled field current feedback

Range: xxx.xx %

Configuration Enable
When enabled, allow configuration changes but suspends control operation.

Range: 0 : Disabled
1 : Enabled

NOM Motor Volts
Set this value to match the armature volts rating of the motor.

Range: 100 to 875 Volts

Armature Current
Set this value to match the armature current rating of the motor.

Range: 2.0 to 15.0 AMPS

Field Current
Set this value to match the Field Current rating of the motor.

Range: 0.2 to 4.0 AMPS

Armature V CAL
Trim adjustment of the motor armature volts to give exactly 100% at the required actual voltage value (e.g. 460V etc.).

Range: 0.9800 to 1.1000

Note: Primary voltage calibration is achieved by adjusting VA calibration values using SW7.

IR Compensation
Compensation for motor IR drop to improve regulation when using armature voltage feedback as the speed feedback. This is also used in field weakening applications to improve dynamic response and speed holding stability, refer to "initial start-up routine".

Range: 0.00 to 100.00 %

Calibration Continued

Parameter Descriptions Continued

Encoder RPM Range: 0 to 6000 RPM
Max motor speed when using encoder feedback.

Encoder Lines Range: 10 to 5000
Sets the lines per revolution value of the encoder being used.

Analog TACH CAL Range: 0.9800 to 1.1000
Trim adjustment of the motor speed to give exactly 100% at the required actual speed value (e.g. 1500 RPM etc). Note: Primary tachometer calibration is achieved by adjusting SW1 – 3 on the tachometer calibration board.

Zero SPD. Offset Range: –5.00 to 5.00 %
If the speed feedback is not zero when the drive is stationary (possibly due to hardware offsets etc.), set this parameter value to result in a zero reading from the speed feedback.

Armature I (A9) Range: 0 : Unipolar
Selects bipolar or unipolar operation of the current meter output (terminal A9).
1 : Bipolar

SPDFBK ALM LEVEL Range: 0.00 to 100.00 % (h)
The speed feedback alarm compares speed feedback to armature voltage. The alarm level is the maximum difference between the two signals before the alarm is activated.

Stall Threshold Range: 0.00 to 200.00 %
Stall comparator current feedback threshold level.

Stall Trip Delay Range: 0.1 to 600.0
Stall comparator time-out delay before stall output becomes true.
Seconds

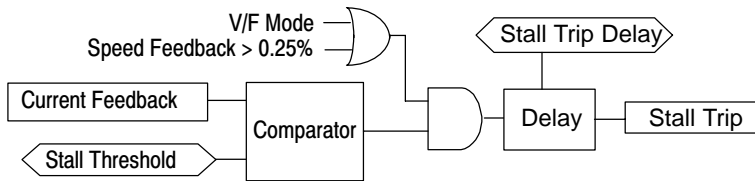

Overspeed Level Range: 0.00 to 200.00 %
Speed feedback level for overspeed alarm

FIELD I CAL Range: 0.9800 to 1.1000
Trim adjustment of the motor field current to give exactly 100% at the required actual current value (e.g. 1.5A etc.).

Note: Primary field calibration is achieved by adjusting IF calibration using SW1 – 3.

Configure Drive This menu contains many of the parameters required for configuring the drive. The Configure Drive menu is only available at the keypad.

Note: Control operation is suspended and all Keypad LEDs will flash while the Configure Enable = Enabled.

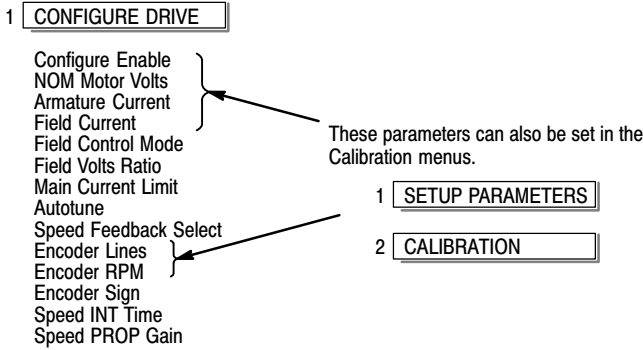

Parameter Descriptions

Configuration Enable

When enabled, allow configuration changes but suspends control operation.

Range: 0 : Disabled
1 : Enabled

NOM Motor Volts

Set this value to match the armature volts rating of the motor.

Range: 100 to 875 Volts

Armature Current

Set this value to match the armature current rating of the motor.

Range: 2.0 to 15.0 AMPS

Field Current

Set this value to match the Field Current rating of the motor.

Range: 0.2 to 4.0 AMPS

Zero CAL Inputs

Range: 0 : Up to Action
1 : Requested

Field Control Mode

Range: 0 : Voltage Control
1 : Current Control

Field Volts Ratio

Range: 0.00 to 100.00 % (h)

Main Current Limit

Range: 0.00 to 200.00 %

Autotune

Range: 0 : OFF
1 : ON

Speed Feedback Select

Range: 0 : ARM Volts FDBK
1 : Analog Tach
2 : Encoder
3 : Encoder/Analog

Encoder Lines

Sets the encoder lines per revolution.

Range: 10 to 5000

Encoder RPM

Max motor speed when using encoder feedback.

Range: 0 to 6000 RPM

Encoder Sign

The polarity of the encoder signal.

Range: 0 : Negative
1 : Positive

Speed INT Time

Range: 0.001 to 30.000
Seconds

Speed PROP Gain

Range: 0.00 to 200.00

Current Loop Allows parameters to be customized for the conventional current loop (torque loop) of the control.

1 **SETUP PARAMETERS**

2 **CALIBRATION**

- Configure Enable
- NOM Motor Volts
- Armature Current
- Field Current
- Armature V CAL
- IR Compensation
- Encoder RPM
- Encoder Lines
- Analog TACH CAL
- Zero SPD Offset
- Armature I (A9)
- SPDFBK Alarm Level
- Stall Threshold
- Stall Trip Delay
- REM Trip Delay
- Overspeed Level
- Field I CAL

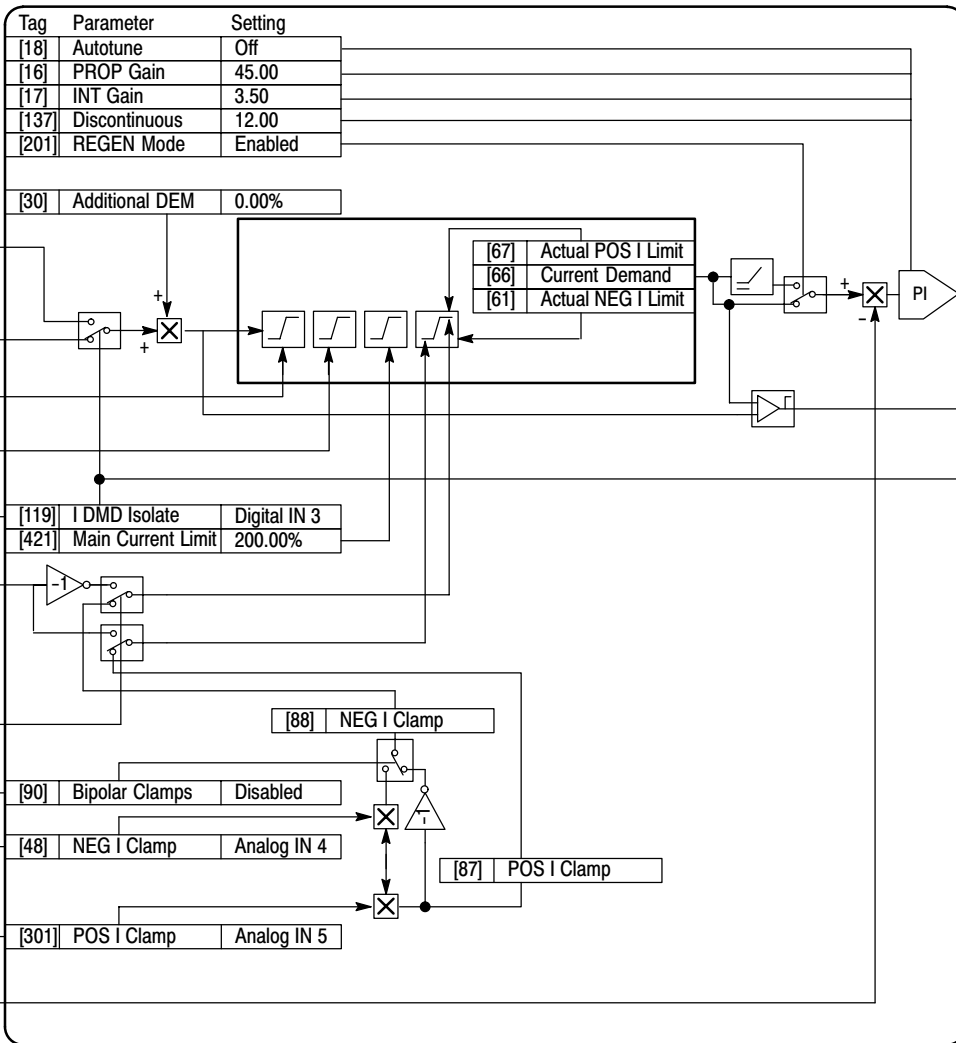

Note 1: IDMD isolate removes speed loop demand and selects analog I/P 2 as current regulator demand. IDMD isolate is overridden by program stop and stop to return drive to speed regulation.

Note 2: Regen mode disable prevents negative current demand. Series 29 Non-regenerative drives should have regen mode disabled.

Current Loop Continued

Parameter Descriptions

At Current Limit (Read in Diagnostics Parameters) True indicates that current demand equals or exceeds maximum current limit.	Range: 0 : False 1 : True
IA Demand (Read in Diagnostics Parameters) (IaDmd Unfiltered)	Range: xxx.xx % (h)
IA Feedback (Read in Diagnostics Parameters) (IaFbk Unfiltered)	Range: xxx.xx % (h)
Current FBK.AMPS (Read in Diagnostics Parameters) Scaled and filtered armature current in Amps.	Range: xxx.xx AMPS
IF Feedback (Read in Diagnostics Parameters) (Field I FBK.AMPS)	Range: xxx.xx AMPS
Autotune This is the autotune function trigger input.	Range: 0 : Off 1 : On
ILOOP Suspend Reserved parameter.	Range: 0 : False 1 : True
Master Bridge A diagnostic indicating currently active bridge; master = ON, slave = OFF.	Range: 0 : Off 1 : On
Main CURR. Limit Main current limit parameter which is independent of current limit scaler and in series with the other three current limit blocks.	Range: 0.00 to 200.00 %
PROP Gain Proportional gain control for armature current pi loop. this parameter is set during the autotune function.	Range: 0.00 to 200.00
INT Gain Integral gain control for armature current PI loop. This parameter is set during the autotune function.	Range: 0.00 to 200.00
Feed Forward Set by Autotune but not used by the factory set I-Loop mode	Range: 0.10 to 50.00
Discontinuous Discontinuous-to-continuous mean armature current boundary level. This parameter is set during the autotune function and affects the performance of the adaptive algorithm.	Range: 0.00 to 200.00 %
Additional DEM Additional current demand input	Range: -200.00 to 200.00 %
Bipolar Clamps Select input for bipolar (asymmetric) or unipolar (symmetric) current clamps for the 4 quadrants of operation. Factory setting of DISABLED means UNIPOLAR clamps selected.	Range: 0 : Disabled 1 : Enabled
Regen Mode – Series 30 controls only Set mode for regenerative (4-quadrant) or non-regenerative (2-quadrant) operation. Do not changed while the control is in operation.	Range: 0 : 2Q (Non-regen) 1 : 4Q (Regen)
POS. I Clamp Positive current clamp in Bipolar Clamp mode.	Range: -100.00 to 100.00 %
NEG. I Clamp Negative current clamp in Bipolar Clamp mode.	Range: -100.00 to 100.00 %
Note: Note bipolar current clamps in bipolar mode can cross over onto the same quadrant as long as the POS. I Clamp is always algebraically greater than the NEG. I Clamp.	
CUR. LIMIT/SCALER Current limit scaler. It scales bipolar/unipolar clamps.	Range: 0 to 200.00 %
I DMD Isolate Speed loop bypass: the current demand input is ANIN2 (A3). The following diagram shows that I DMD Isolate selects the controlling loop.	Range: 0 : Disabled 1 : Enabled

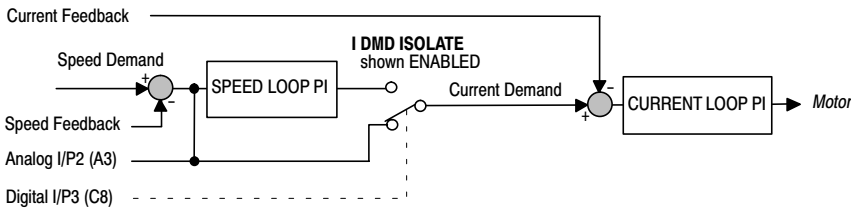

Current Profile When speed control is obtained by field weakening, the ability of the motor to commutate armature current is reduced at low field currents. Also some motors exhibit commutation limitations at higher speeds even with rated field current.

1 **SETUP PARAMETERS**

2 **CURRENT PROFILE**

Speed Break 1 (Low)
 Speed Break 2 (High)
 IMAX Break 1 (SPD1)
 IMAX Break 2 (SPD2)

Current Profile	
100.0%	[32] SPD BRK 1 (Low)
100.0%	[31] SPD BRK 2 (High)
200.0%	[93] IMAX BRK 1 (SPD1)
200.0%	[33] IMAX BRK 2 (SPD2)

Parameter Descriptions

SPD BRK 1 (LOW)

The motor speed at which current limit profiling begins.

Range: 0.00 to 100.00 % (h)

SPD BRK 2 (HIGH)

The upper speed limit at which current limit profiling ends.

Range: 0.00 to 100.00 % (h)

IMAX BRK 1 (SPD1)

This sets the current limit value at or below speed break–point 1, provided the other current limits are greater than this setting.

Range: 0.00 to 200.00 % (h)

IMAX BRK 2 (SPD2)

This sets the current limit value at or above speed break–point 2, provided the other current limits are greater than this setting.

Range: 0.00 to 200.00 % (h)

Functional Description

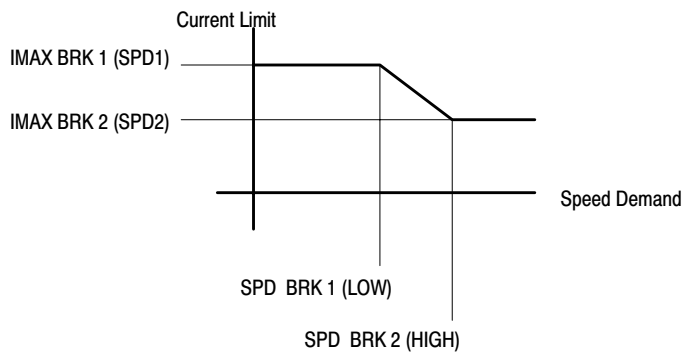

Diagnostics

This function block is used to monitor the status of the drive, internal variables, and its inputs and outputs.

1 DIAGNOSTICS

Diagnostics

Speed Demand	Operating Mode	Raise/Lower Output
Speed Feedback	Field Enable	PID Output
Speed Error	Field Demand	PID Clamped
Speed Loop Output	Field I FBK	PID Error
Current Demand	Field I FBK AMPS	Setpoint Sum Output
Current Feedback	UNFIL Field FBK	Ramp Output
Current FBK AMPS	Field Firing Angle	Speed Setpoint
laFBK Unfiltered	ANIN1 (A2)	Terminal Volts
laDemand Unfiltered	ANIN2 (A3)	Back EMF
POS I Clamp	ANIN3 (A4)	TACH Input (B2)
NEG I Clamp	ANIN4 (A5)	Raw TACH Input
Actual POS I LIM	ANIN5 (A6)	Encoder
Actual NEG I LIM	ANOUT 1 (A7)	Raw Encoder RPM
Inverse Time Output	ANOUT 2 (A8)	Raw Speed Feedback
At Current Limit	Start (C3)	Raw Speed Error
At Zero Speed	Digital Input C4	Contactor Closed
At Zero Setpoint	Digital Input C5	Health LED
At Standstill	DIGIN 1 (C6)	Ready
Ramping	DIGIN 2 (C7)	Drive Running
Program Stop	DIGIN 3 (C8)	System Reset
Coast Stop	DIGOUT 1 (B5)	
Drive Start	DIGOUT 2 (B6)	
Drive Enable	DIGOUT 3 (B7)	

Speed Feedback [207]	0.06%
Speed Error [297]	0.06%
Current Demand [299]	0.00%
Current Feedback [298]	0.00%
POS I Clamp [87]	100.0%
NEG I Clamp [88]	-100.0%
Actual POS I Limit [67]	100.0%
Actual NEG I Limit [61]	-100.0%
Drive Start [82]	OFF
Drive Enable [84]	Disabled
Field I Feedback [300]	0.0%
TACH Input (B2) [308]	0.2%
Encoder [206]	0 RPM
Drive Running [376]	
Contactor Closed [83]	

Parameter Descriptions

Speed Feedback (Also set in Speed Loop Parameters) Speed loop feedback. The speed feedback value from the source selected by Speed Feedback Select [47].	Range: xxx.xx %
Speed Error (Diagnostics only) Speed Loop Error.	Range: xxx.xx %
Current Demand (Diagnostics only) Current Loop Demand (speed error PI output or external current demand clamped by all the current limits).	Range: xxx.xx %
Current Feedback (Diagnostics only) Scaled and filtered armature current.	Range: xxx.xx %
POS. I Clamp (Diagnostics only) Positive current clamp.	Range: xxx.xx % (h)
NEG. I Clamp (Diagnostics only) Negative current clamp.	Range: xxx.xx % (h)
ACTUAL POS I LIM (Diagnostics only) Overall positive current limit value.	Range: xxx.xx % (h)
ACTUAL NEG I LIM (Diagnostics only) Overall negative current limit value.	Range: xxx.xx % (h)
DRIVE START (Diagnostics only) Controller start/run command.	Range: 0 : Off 1 : On
Drive Enable (Diagnostics only) Drive speed and current loop are enabled/quenched.	Range: 0 : Disabled 1 : Enabled
FIELD I FBK (Diagnostics only) Scaled field current feedback	Range: xxx.xx %
TACH INPUT (B2) (Diagnostics only) Scaled analog tachogenerator feedback.	Range: xxx.xx % (h)
ENCODER (Diagnostics only) Encoder speed feedback in RPM.	xxxxx RPM
Speed Demand (shown in Stop Rates block) Speed loop total setpoint after the ramp-to-zero block.	Range: xxx.xx %
Speed Loop Output (shown in Speed Loop block) Output from speed loop PI.	Range: xxx.xx %
Current FBK. AMPS (shown in Current Loop block) Scaled and filtered armature current in Amps. (IA Feedback)	Range: xxx.xx AMPS
laFBK Unfiltered (shown in Current Loop block) Scaled armature current.	Range: xxx.xx %
laDmd Unfiltered (shown in Current Loop block) Scaled demanded armature current.	Range: xxx.xx %

Diagnostics Continued

Parameter Descriptions

Inverse Time Output (shown in Current Loop block) Inverse time clamp output level.	Range: xxx.xx %
At Current Limit (shown in Current Loop block) Current demand is being restrained by the overall current limit.	Range: 0 : False 1 : True
At Zero Speed (shown in Standstill block) At zero speed feedback.	Range: 0 : False 1 : True
At Zero Setpoint (shown in Standstill block) At zero speed demand.	Range: 0 : False 1 : True
At Standstill (shown in Standstill block) At zero speed and at zero setpoint.	Range: 0 : False 1 : True
Ramping (shown in Ramps block) If the difference between the Ramp Input and The Ramp Output is greater than the Ramp Threshold, then Ramping is true.	Range: 0 : False 1 : True
Program Stop (shown in Stop Rates block) State of Program Stop (Terminal B8). When B8 is at 24V, then Program Stop is false and the Program Stop front panel LED is also on.	Range: 0 : False 1 : True
Coast Stop (Diagnostics only) State of Coast Stop (Terminal B9). When B9 is at 24V, then Coast Stop is False.	Range: 0 : False 1 : True
Operating Mode (shown in Jog/Slack block) Sets the drive mode to Run, Jog 1....stop, etc. 0 : Stop 1 : Stop 2 : Jog Sp. 1 3 : Jog Sp. 2 4 : Run 5 : Take Up Sp. 1 6 : Take Up Sp. 2 7 : Crawl	Range: 0 to 7
Field Enabled (shown in Field Control block) Drive Field Loop Is Enabled/Quenched.	Range: 0 : Disabled 1 : Enabled
Field Demand (shown in Field Control block) The meaning of field demand depends upon which mode of field control is in force; in current control field demand is the current setpoint to the field loop, in voltage mode field demand is the voltage ratio to the field controller.	Range: xxx.xx %
FIELD I FBK AMPS (shown in Current Loop block, IF Feedback) Scaled and filtered field current feedback in Amps.	Range: xxx.xx %
Raw Field FBK Scaled field current.	Range: xxx.xx %
FLD. Firing Angle (shown in Field Control block) Field firing angle in degrees: 155 degrees is the value for back stop (min field) and 5 degrees is the value for front stop (max field).	Range: xxx.xx DEG
ANIN 1 (A2) (shown in Analog Inputs block) Speed setpoint no. 1.	Range: xxx.xx Volts
ANIN 2 (A3) (shown in Analog Inputs block) Speed setpoint no. 2/current demand.	Range: xxx.xx Volts
ANIN 3 (A4) (shown in Analog Inputs block) Speed setpoint no. 3 (ramped).	Range: xxx.xx Volts
ANIN 4 (A5) (shown in Analog Inputs block) Negative current clamp; this is only active if bipolar clamps are enabled (C6 = ON)	Range: xxx.xx Volts
ANIN 5 (A6) (shown in Analog Inputs block) Main current limit or positive current clamp if C6 = on.	Range: xxx.xx Volts
ANOUT 1 (A7) (shown in Analog Outputs block) Scaled speed feedback.	Range: xxx.xx Volts
ANOUT 2 (A8) (shown in Analog Outputs block) Total speed setpoint.	Range: xxx.xx Volts
Start (C3) (shown in AUX I/O block) Start/Run terminal.	Range: 0 : Off 1 : On

Diagnostics Continued

Parameter Descriptions

Digital Input C4 Enable terminal.	Range: 0 : Off 1 : On
Digital Input C5 Reverse terminal.	Range: 0 : Off 1 : On
DIGIN 1 (C6) Jog/Slack terminal.	Range: 0 : Off 1 : On
DIGIN 2 (C7) Jog/Slack Mode terminal.	Range: 0 : Off 1 : On
DIGIN 3 (C8) Speed or Torque mode select terminal.	Range: 0 : Off 1 : On
DIGOUT 1 (B5) (shown in Digital Outputs block) At zero speed.	Range: 0 : Off 1 : On
DIGOUT 2 (B6) (shown in Digital Outputs block) Drive healthy. Health is also displayed on the front panel LED.	Range: 0 : Off 1 : On
DIGOUT 3 (B7) (shown in Digital Outputs block) Drive ready to run (all alarms healthy and mains synchronization achieved).	Range: 0 : Off 1 : On
Raise/Lower Output (shown in Raise/Lower block) (OUTPUT) Value of the raise/lower ramp function.	Range: xxx.xx %
PID Output (shown in PID block) PID block output.	Range: xxx.xx %
PID Clamped (shown in PID block) Logic output indicating whether the PID limits are active.	Range: 0 : False 1 : True
PID Error (shown in PID block) PID error = Input 1 – Input 2	Range: xxx.xx %
SPT Sum Output (shown in Setpoint Sum 1 block) Setpoint sum 1 output.	Range: xxx.xx %
Ramp Output (shown in Ramps block) Setpoint ramp output.	Range: xxx.xx %
Speed Setpoint (shown in Speed Loop block) Speed loop total setpoint including the ramp output before the ramp-to-zero function.	Range: xxx.xx %
Terminal Volts (shown in Calibration block) Scaled terminal volts.	Range: xxx.xx % (h)
Back EMF (shown in Calibration block) Calculated motor back EMF including IR compensation.	Range: xxx.xx % (h)
UNFIL TACH Input (shown in Calibration block) Unfiltered analog tachogenerator feedback.	Range: xxx.xx % (h)
Encoder (Diagnostics only) Encoder speed feedback in RPM.	Range: xxxxx RPM
Raw Encoder RPM (shown in Calibration block) Unfiltered encoder speed feedback in RPM.	Range: xxxxx RPM
UNFIL Speed FBK (shown in Speed Loop block) Unfiltered speed feedback.	Range: xxx.xx %
UNFIL Speed Error (shown in Speed Loop block) Unfiltered speed error.	Range: xxx.xx %
Contactors Closed (Diagnostics only) Main contactor control signal.	Range: 0 : Off 1 : On
HEALTH LED (shown in Alarms block) State of Health LED on Operator Station.	Range: 0 : False 1 : True
READY (shown in Alarms block) The drive is ready to accept an enable signal.	Range: 0 : False 1 : True
DRIVE RUNNING (Diagnostics only) Drive is enabled and may make current when TRUE. A diagnostic for those parameters that can only be written to when the drive is stopped (parameters marked with Note 2 in the Parameter Specification Table).	Range: 0 : False 1 : True
SYSTEM RESET (Diagnostics only) Set for one cycle as the drive is enabled.	Range: 0 : False 1 : True

Digital Inputs Allows control of the digital operating parameters of the software. The digital input can be configured to point to a destination location and to set that destination true or false depending upon programmable values.

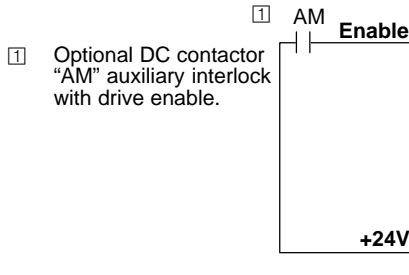
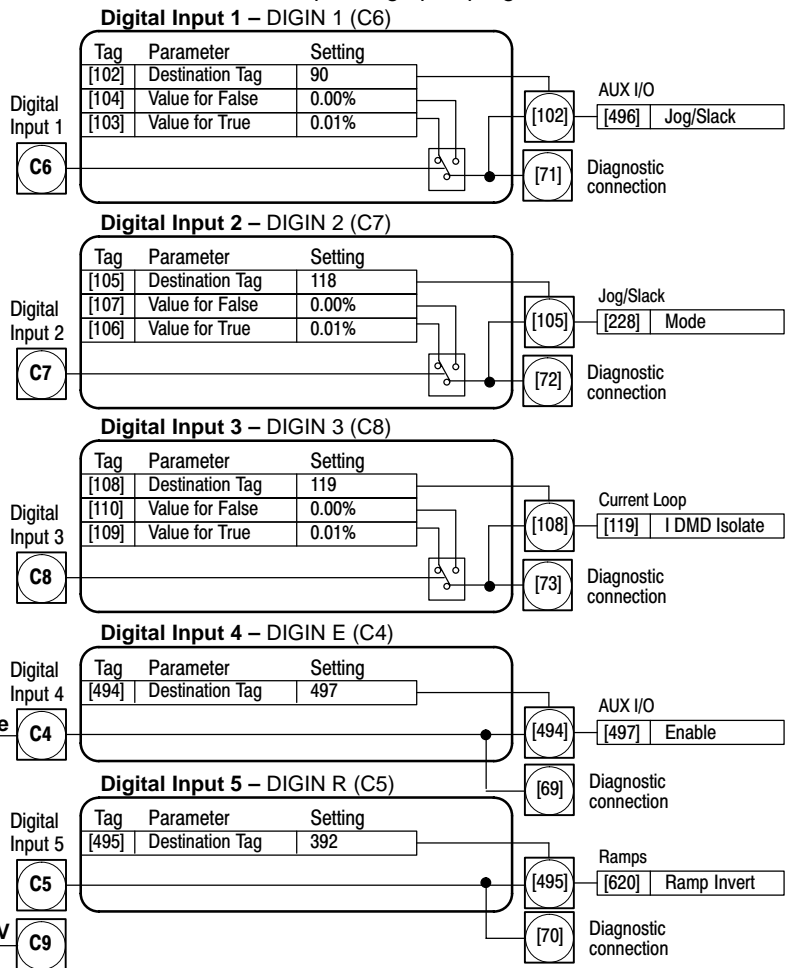
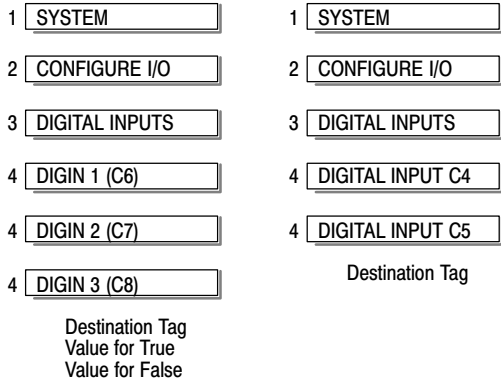

Parameter Descriptions

- Destination Tag** (Output) Range: 0 to 549
The destination Tag No. assigned to the digital input.
- Value for True** Range: -300.00 to 300.00 %
The value that output assumes when input is true.
- Value for False** Range: -300.00 to 300.00 %
The value that output assumes when input is false.
- Digital Inputs 1, 2, and 3** (Also see AUX I/O and Diagnostics blocks) Range: 0 : Off
Refer to the diagnostics function block description. 1 : On
- Digital Input C4** (Also see AUX I/O and Diagnostics Parameters) Range: 0 to 549
Electronic enable/quench terminal (On=Enable). If terminal C4 is used for anything other than "Drive Enable" ([494] is not set to 497), then the enable parameter [497] must be set to ON or the drive will not run.
Digital Inputs C4 and C5 have destination tags only.
Note: Value true is fixed at 0.01%, and value false is fixed at 0.00%.
- Digital Input C5** (Also see AUX I/O and Diagnostics Parameters) Range: 0 to 549
Reverse is active when C5 is true. This causes [620] Ramp Invert to reverse (change polarity) of the ramped output signal to Setpoint 1 [289] of the Speed Loop.
Digital Inputs C4 and C5 have destination tags only.
Note: Value true is fixed at 0.01%, and value false is fixed at 0.00%.

Digital Inputs Continued

Functional Description

The destination for a digital input can be any valid Tag number. This means that a digital input can be used to select one of two values for a given parameter. It is also possible to treat the values for true and false as destination tags from other functions or inputs. 0.00% = a Logic 0 and any other value = a Logic 1. This refers to the values set in both value for true and value for false parameters. Inverting the digital input is therefore simple; set value true to 0.00% and value false to 0.01% or any other non-zero number.

Input	Description
Digital input 1 Terminal (C6)	Jog/Slack digital input. (See Jog/Slack description).
Digital input 2 Terminal (C7)	Jog/Slack mode digital input. (See Jog/Slack description).
Digital input 3 Terminal (C8)	Speed/Torque select input. Closed allows a direct current output command from Analog Input 2. The bipolar signal from Analog 2 is direct acting without any accel or decel ramp rates. Connection from another command signal source is not possible.

Digital Inputs – Examples Digital inputs can be connected to read/write parameters only. These inputs are useful to control logical parameters. Logical parameters are those whose ranges are On/Off, True/False, Enabled/Disabled, etc. They can also send two fixed values to a VALUE parameter as determined by the state of the input terminal.

Example 1 – Using an Analog Input as a Digital Input

It is possible to use an Analog Input as a Digital Input to extend the number of Digital Inputs available. Again, 0.00% is regarded as Logic 0 and any other value is regarded as Logic 1.

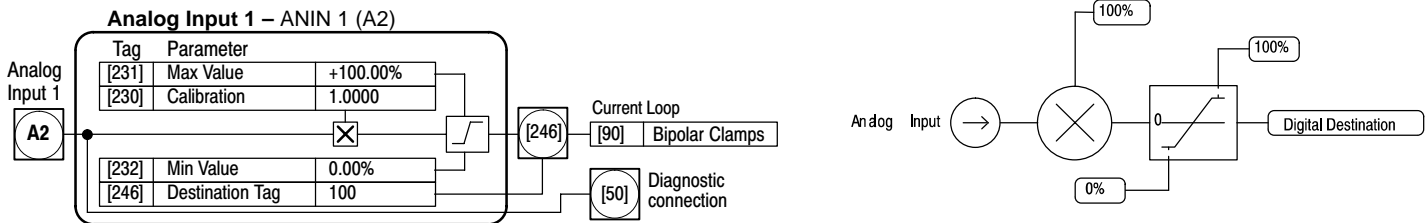

Example 2 – Using digital inputs with LOGIC parameters

The factory settings allow the digital inputs to switch LOGIC parameters. These are the connections from terminal C6 to tag 90 (Bipolar Clamps), C7 to tag 118 (Ramp Hold), and C8 to tag 119 (I DMD. Isolate). In each case, the state of the terminal switches the destination parameter on or off by sending a 1 or 0. Since the format of the Value For True and Value For False parameters is in percent, 0 is equal to 0.00% and 1 is equal to 0.01%.

Inverting the Input Signal

1. Set CONFIGURE I/O::CONFIGURE ENABLE To Enable.
2. Set DIGIN 1 (C6)::VALUE FOR TRUE to 0.00%.
3. Set Value for False to 0.01%.
4. Reset CONFIGURE I/O::CONFIGURE ENABLE To Disable.

Digital Inputs Continued

Digital input 1 now sends a 0 when the input signal is true and 1 when it is false.

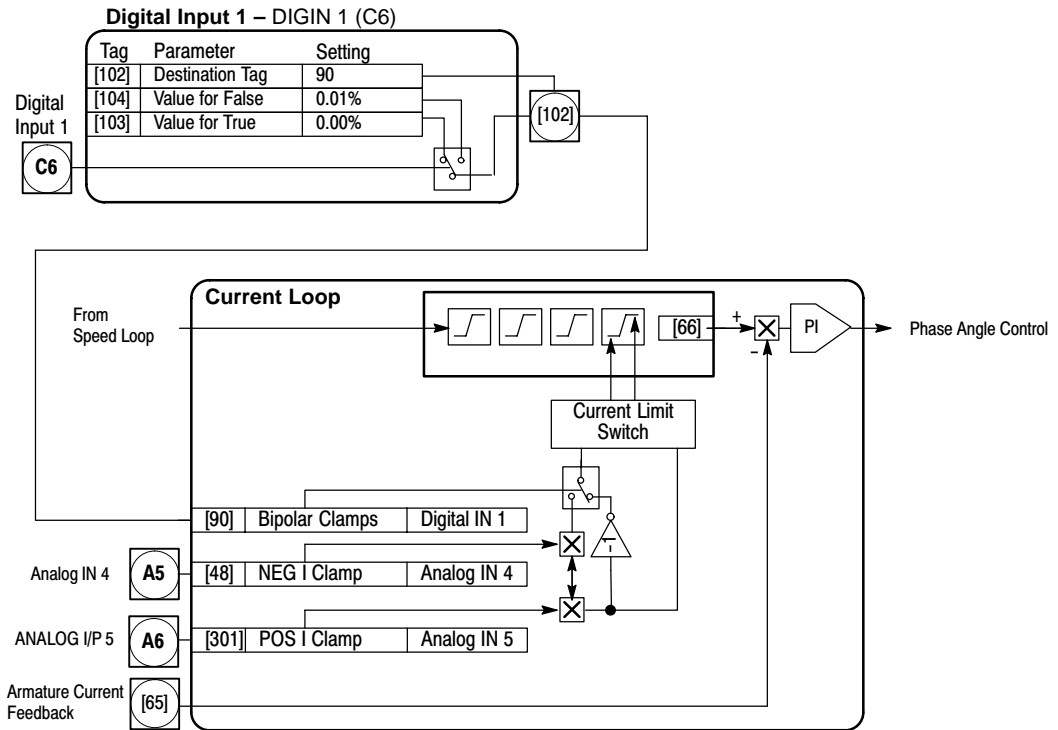

Example 3 – Use Digital Input 1 to set Speed Loop PROP Gain

1. Set CONFIGURE I/O::CONFIGURE ENABLE to ENABLE.
2. Set DIGIN 1 (C6)::DESTINATION TAG to 14 (the speed loop prop gain parameter).
3. Set VALUE FOR TRUE to 10.00.
4. Set VALUE FOR FALSE to 30.00.
5. Reset CONFIGURE I/O::CONFIGURE ENABLE to DISABLE.

Digital input 1 now sets SPEED LOOP::PROP. GAIN to two values depending upon its state. When it is HIGH, PROP. GAIN is at 10.00 and when LOW, PROP. GAIN is at 30.00.

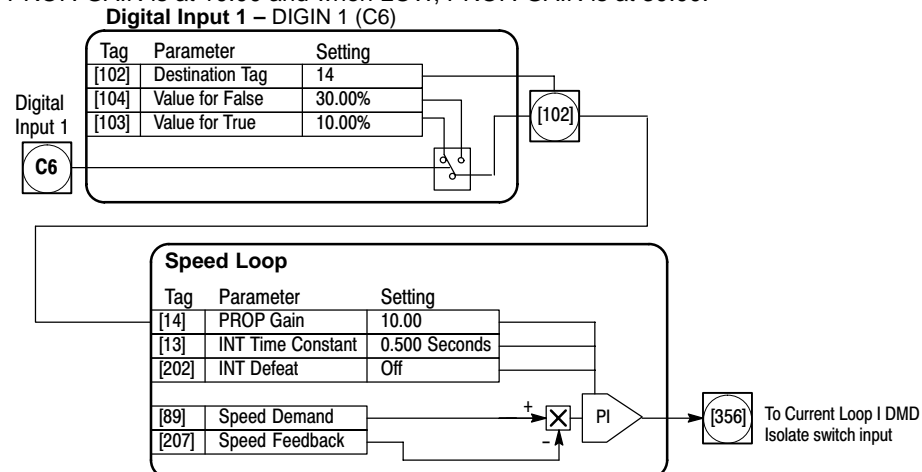

Digital Inputs Continued

Example 4 – Use Digital Input 1 to switch signal sources

1. Set CONFIGURE I/O::CONFIGURE ENABLE to ENABLE.
2. Set DIGIN 1 (C6)::DESTINATION TAG to 364 (Link 1 source tag parameter).
3. Set DIGIN 1 (C6)::VALUE FOR TRUE to 1.29% (tag number for AUX I/O::ANOUT 2=129).
4. Set DIGIN 1 (C6)::VALUE FOR FALSE to 1.28% (tag number for AUX I/O::ANOUT 1=128).
5. Set LINK 1::DESTINATION TAG to 309 (SETPOINT SUM::INPUT 0 parameter).
6. Set AUX I/O::ANOUT 1 to 10%.
7. Set AUX I/O::ANOUT 2 to 20%.
8. Reset CONFIGURE I/O::CONFIGURE ENABLE to Disable.

This example uses an internal link to route two signals to Input 0. The state of digital input 1 determines the number held by LINK 1 :: SOURCE TAG. When true, it is 129. When false, the tag is 128. LINK 1:: SOURCE TAG retrieves the value from ANOUT 1 or 2 depending on the tag and routes it to SETPOINT SUM 1:: INPUT 0. The signal switches between 10 and 20 percent. This is useful for switching between two jog setpoints.

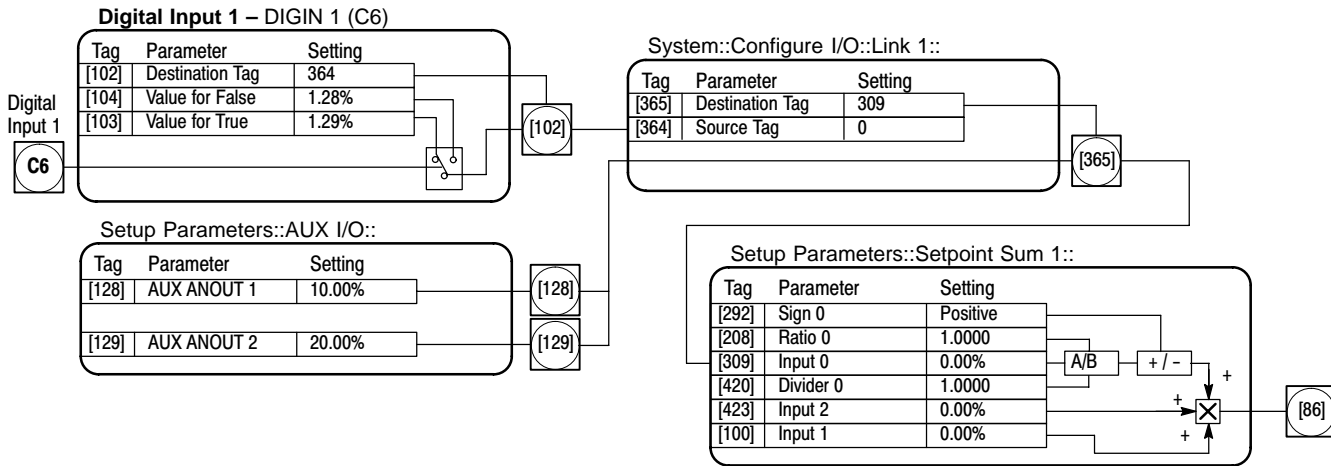

Digital Outputs Digital outputs can read all parameters (the same as the analog outputs). When used with a VALUE parameter, MODULUS removes the sign from the value (so -100 becomes 100). The THRESHOLD (>) parameter determines when the output is HIGH or LOW. The input signal must exceed the Threshold value for the output to go HIGH. INVERTED, when TRUE, inverts the result of the output from the threshold test.

- 1 SYSTEM
- 2 CONFIGURE I/O
- 3 DIGITAL OUTPUTS
- 4 DIGOUT1 (B5)
- 4 DIGOUT2 (B6)
- 4 DIGOUT3 (B7)

Threshold (>)
Modulus
Source Tag
Inverted

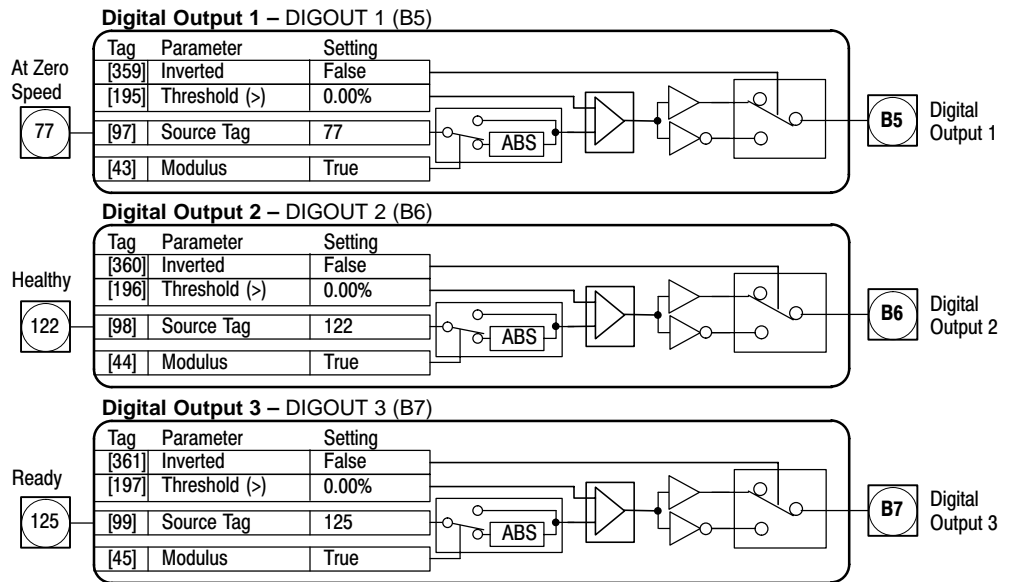

Parameter Descriptions

- Threshold (>)** Range: -300.00 to 300.00 %
The threshold which the value must exceed to set the output to true.
- Modulus** Range: 0 : False
1 : True
Output set TRUE for absolute or modulus of the tag no. value.
- Source Tag (Input)** Range: 0 to 549
Defines the source variable to control the digital output.
- Inverted** Range: 0 : False
1 : True
Selects Inverted Output.
- DIGOUT 1, 2 , and 3 (Read in Diagnostics Parameters)** Range: 0 : Off
1 : On
Refer to the diagnostics function block description.

Field Control

This function block contains all the parameters for the field operating mode. It is viewed at the keypad in three submenus. In the Field Control menu, you select the field operating mode: open loop voltage control or closed loop current control.

In certain DC motor applications, high speeds can only be achieved by reducing the field current (torque). This is the constant horsepower region or field weakening region, and the speed at which it begins is known as the Base Speed.

- 1 SETUP PARAMETERS
- 2 FIELD CONTROL
- 3 FLD CURRENT VARS
- 4 FLD WEAK VARS
- 1 CONFIGURE DRIVE
- 3 FLD VOLTAGE VARS

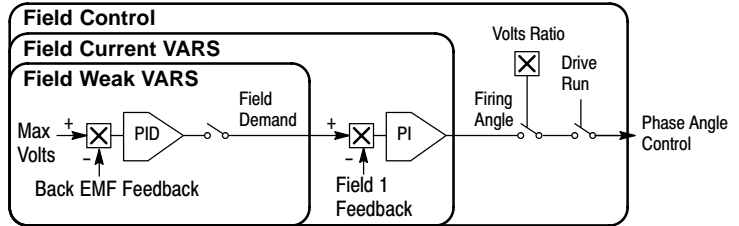

Parameter Descriptions

- Field Enabled** (Read in Diagnostics Parameters)
Refer to the diagnostics function block description. Range: 0 : Disabled
1 : Enabled
- Field Demand** (Read in Diagnostics Parameters)
Refer to the diagnostics function block description. Range: xxx.xx %
- Field Firing Angle** (Read in Diagnostics Parameters)
Refer to the diagnostics function block description. Range: xxx.xx DEG
- Field Enable**
Unquenches Field Current Loop. Range: 0 : Disabled
1 : Enabled
- Field Control Mode** Two modes are available
(a) Field Voltage Control is an open loop phase angle control to give a certain voltage output. Range: 0 : Voltage Control
(b) Field Current Control is a closed loop current control for accurate field control or expansion to field weakening. 1 : Current Control
- Field Volts Ratio** (Ratio Out/In)
This parameter controls the output voltage from the open loop voltage control. The ratio is defined as the dc output voltage over the ac rms input voltage. The factory setting is equivalent to a single-phase diode rectifier. Range: 0.00 to 100.00 % (h)
- Setpoint**
Field Current Setpoint. Range: 0.00 to 100.00 %
- PROP. Gain**
This is the proportional gain adjustment of the field current pi loop. The factory setting of 0.10 is equivalent to a real gain of 10. Range: 0.00 to 100.00 %
- INT. Gain**
This is the integral gain adjustment of the field current PI loop. Range: 0.00 to 100.00 %
- Field Weak Enable**
Activates the additional motor back emf PID loop for field weakening (field spillover) control. Range: 0 : Disabled
1 : Enabled
- EMF LEAD**
With field weakening control enabled, a PID loop is brought into operation. This is the lead time constant adjustment of the field weakening PID loop. For a value of 2.00, the real time constant = 200ms. Range: 0.10 to 50.00
- EMF LAG**
This is the lag time constant adjustment of the field weakening PID loop. For a value of 4.00, the real time constant = 4000ms. Range: 0.00 to 200.00
- EMF GAIN**
This is the gain adjustment of the field weakening PID loop. For a value of 3.00, the real gain = 30. Range: 0.00 to 100.00
- MIN FIELD CURRENT**
The field weakening loop reduces the field current to achieve speed control above base speed. At top speed the field reaches a minimum value. The Min Fld Current should be set below this minimum value to allow reasonable margin for transient control near the top speed but not lower than 6% as this could then cause the "Field Fail" alarm to operate. Range: 0.00 to 100.00 %

Field Control Continued

Parameter Descriptions

MAX VOLTS

The voltage level at which field weakening begins. It is also known as “Spillover Bias”. The factory setting value is 100% of the nominal value as set by the armature voltage calibration value. For start-up this value can be set to a lower desirable level. It is advisable to return it to 100% for normal operation.

Range: 0.00 to 100.00 %

BEMF FBK LEAD

The lead time constant of the back EMF feedback filter used for reducing armature voltage overshoots when during fast acceleration through base speed.

Range: 10 to 5000

BEMF FBK LAG

The lag time constant of the back EMF feedback filter. If active, the ratio of lead / lag should always be greater than 1 to give an overall lead action (reduces overshoot) and the ratio should be less than 3 for stable control. The factory values 100/100 = 1 make the filter inactive.

Range: 10 to 5000

FLD. QUENCH DELAY

If dynamic braking is used, the field must be maintained for a period after the drive is disabled. The field quench delay is the period of time that the field is maintained.

Range: 0.0 to 600.0 Seconds

FLD. QUENCH MODE

When the field quench delay has expired, the field can be entirely quenched or put into a standby mode at 50% of rated current or volts depending whether in current or voltage control mode respectively. (The factory value of 50% can be modified through the “SYSTEM / Reserved” Menu which is primarily for factory use only and requires the “super” password.)

Range: 0 : Quench
1 : Standby

Functional Description

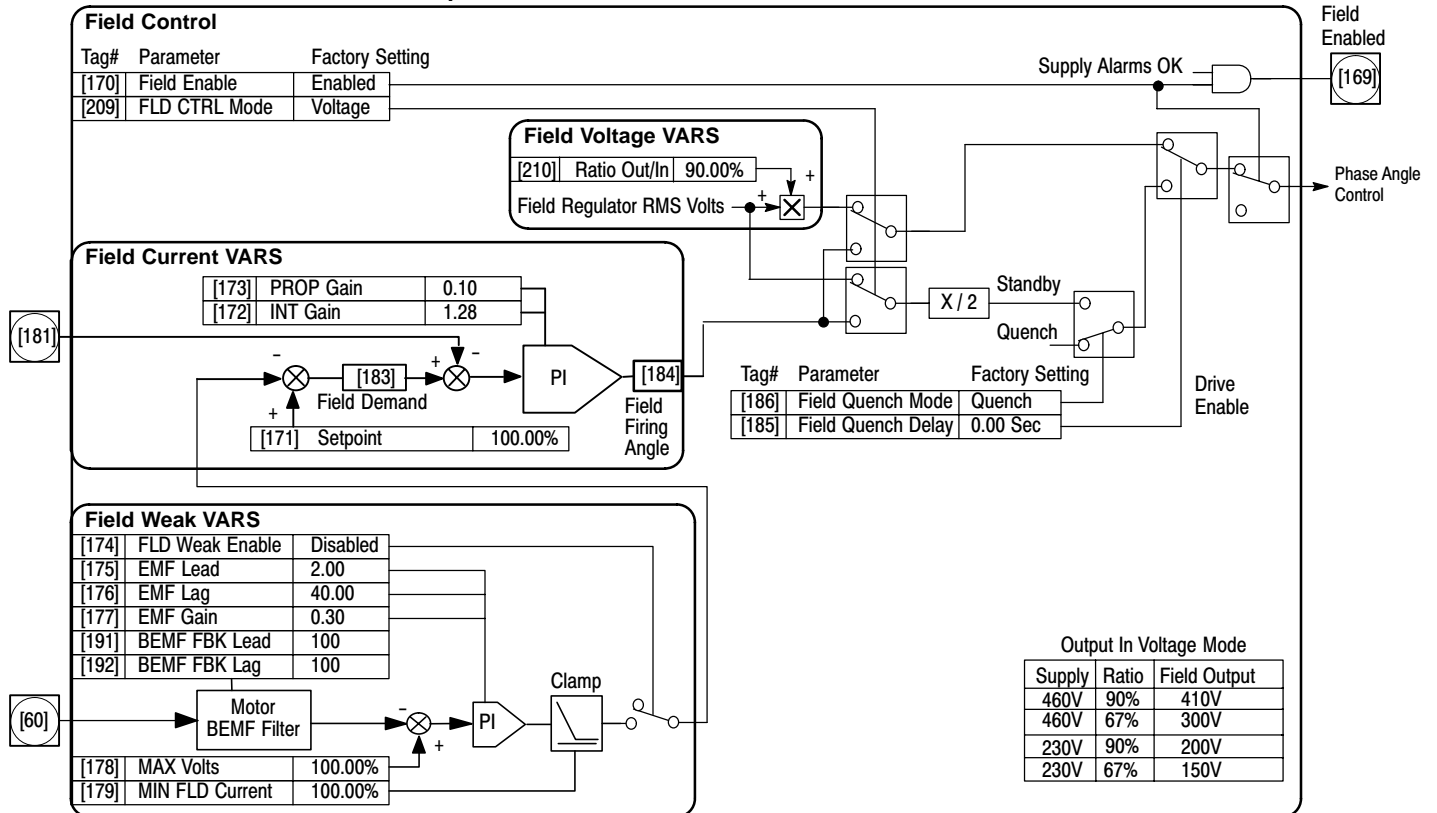

Alarms

This function block provides a view into the present and past trip conditions, and allows some trips to be disabled. It is viewed at the keypad in three menus.

1 SETUP PARAMETERS

1 ALARM STATUS

2 INHIBIT ALARMS

Field Fail
5703 RCV Error
Stall Trip
Trip Reset
Speed FBK Alarm
Encoder Alarm
REM Trip Inhibit

Last Alarm
Health Word
Health Store
Stall Trip
Remote Trip

Field current less than 6%.
(Field fail threshold is 6% in Current control, 12% in Voltage control.)

5703 in Slave Mode and COMMS Error

From Calibration Stall Delay and Stall Threshold

From Calibration SPD FBK Alarm Level

Encoder Feedback Selected and Error Detected

Drive Start ∇

Inhibit Alarms

Tag	Parameter	Setting
[19]	Field Fail	Enabled
[111]	5703 RCV Error	Enabled
[28]	Stall Trip	Inhibited
[81]	Speed FBK Alarm	Enabled
[92]	Encoder Alarm	Enabled
[305]	Trip Reset	True

Alarms

Field Fail
5703 RCV Error
Stall Trip
Speed FBK Alarm
Encoder Alarm
Health Reset

1 SETUP PARAMETERS

2 CALIBRATION

REM Trip Delay

Parameter Descriptions

Healthy (Read in Diagnostics Parameters)
Refer to the diagnostics function block description.

Range: 0 : False
1 : True

Ready (Read in Diagnostics Parameters)
Refer to the diagnostics function block description.

Range: 0 : False
1 : True

Health Word
The hexadecimal sum of any alarms present. Refer to Troubleshooting for more information.

Range: 0x0000 to 0xFFFF

Health Store
The hexadecimal value of the first (or only) alarm. Refer to Troubleshooting for more information.

Range: 0x0000 to 0xFFFF

Remote Trip
The State Of Remote Trip.

Range: 0 : OK
1 : Failed

Stall Trip
Armature current is above stall threshold and at zero speed but not at zero setpoint.

Range: 0 : OK
1 : Failed

Last Alarm
The hexadecimal value of the last (or only) alarm. Refer to Troubleshooting for more information.

Range: 0x0000 to 0xff06

0x0000 : No Active Alarms	0x0080 : Encoder Failed	0x8000 : Accts Failed
0x0001 : Over Speed	0x0100 : Field Failed	0xf001 : Autotune Error
0x0002 : Missing Pulse	0x0200 : 3 Phase Failed	0xf002 : Autotune Aborted
0x0004 : Field Over I	0x0400 : Phase Lock	0xf200 : CONFIG Enabled
0x0008 : Heatsink Trip	0x0800 : 5703 Rcv Error	0xf400 : No Op-station (No Keypad)
0x0010 : Thermistor	0x1000 : Stall Trip	0xf006 : Remote Trip
0x0020 : Over Volts (Va)	0x2000 : Over I Trip	0xff05 : PCB Version
0x0040 : Spd Feedback	0xf005 : External Trip	0xff06 : Product Code

Field Fail
Inhibits the field fail alarm.

Range: 0 : Enabled
1 : Inhibited

5703 RCV Error
Inhibits 5703 serial communications receive error. Only active in slave mode.

Range: 0 : Enabled
1 : Inhibited

Stall Trip
Inhibits the stall trip alarm from tripping the contactor out.

Range: 0 : Enabled
1 : Inhibited

Trip Reset
When false, the faults are latched permanently and the healthy output remains inactive after changing the start input (C3) Off/On. The trip reset must then be set to true for the faults to be reset and the healthy output to go active (high) when C3 goes low. this feature can be used in applications where you want to reset the faults under your own control, rather than automatically with the start/run command.

Range: 0 : False
1 : True

Speed FBK Alarm
Inhibits the speed feedback alarm.

Range: 0 : Enabled
1 : Inhibited

Encoder Alarm
Inhibits the encoder option board alarm.

Range: 0 : Enabled
1 : Inhibited

REM Trip Inhibit
Inhibits the remote trip.

Range: 0 : Enabled
1 : Inhibited

REM Trip Delay
The delay between the remote trip alarm being activated and the drive tripping.

Range: 0 : Enabled
1 : Inhibited

Jog/Slack

These parameters control the Jog function of the control. (Also see "Ramps" description).

1 SETUP PARAMETERS

2 Jog/Slack

Jog Speed 1
Jog Speed 2
Take Up 1
Take Up 2
Crawl Speed
Mode
Ramp Rate

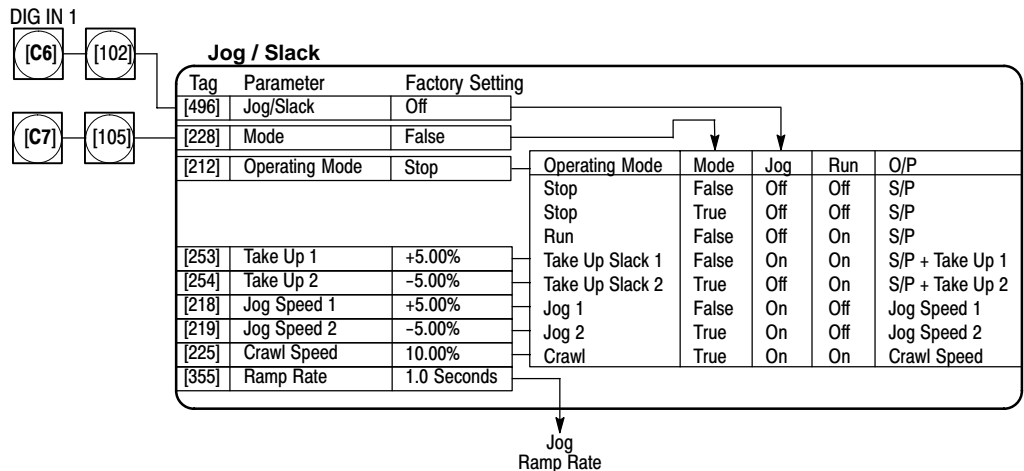

Parameter Descriptions

OPERATING MODE (Read in Diagnostics Parameters)

Refer to the diagnostics function block description.

0 : STOP 2 : JOG SP. 1 4 : RUN 6 : TAKE UP SP. 2
1 : STOP 3 : JOG SP. 2 5 : TAKE UP SP. 1 7 : CRAWL

Range: 0 to 7

JOG SPEED 1

Jog speed 1 setpoint.

Range: -100.00 to 100.00 %

JOG SPEED 2

Jog speed 2 setpoint.

Range: -100.00 to 100.00 %

TAKE UP 1

Take-up slack speed setpoint 1.

Range: -100.00 to 100.00 %

TAKE UP 2

Take-up slack speed setpoint 2.

Range: -100.00 to 100.00 %

CRAWL SPEED

Crawl speed setpoint.

Range: -100.00 to 100.00 %

MODE

Jog/Slack operating mode select. MODE should be connected to a digital input.

Range: 0 : False
1 : True

RAMP RATE

The ramp rate used during Jog is independent of the main ramp rate during normal running. The acceleration and deceleration times in jog are always equal.

Range: 0.1 to 600.0
Seconds

Functional Description

To fully use all the modes, Mode [228] must be connected to one of the digital inputs. "Setpoint" in the following table refers to the MIN Speed Input. Any direct setpoints that exist are added to this setpoint to make the total speed setpoint. If this is not desirable, for example during jog, the direct setpoints should be disconnected during the appropriate conditions.

MIN Speed Input	Operating Mode	Start (C3)	Jog (C6)	Mode (C7)	Ramp Time	Contactors
Setpoint	Stop	OFF	OFF	-	factory setting	OFF
Setpoint	Run	ON	OFF	False	factory setting	ON
Setpoint + Take-Up Slack 1	Take-Up Slack 1	ON	ON	False	factory setting	ON
Setpoint + Take-Up Slack 2	Take-Up Slack 2	ON	OFF	True	factory setting	ON
Crawl Speed	Crawl	ON	ON	True	factory setting	ON
Jog Speed 1	Inch / Jog 1	OFF	ON	False	Jog Accel/Decel Ramp	ON
Jog Speed 2	Inch / Jog 2	OFF	ON	True	Jog Accel/Decel Ramp	ON

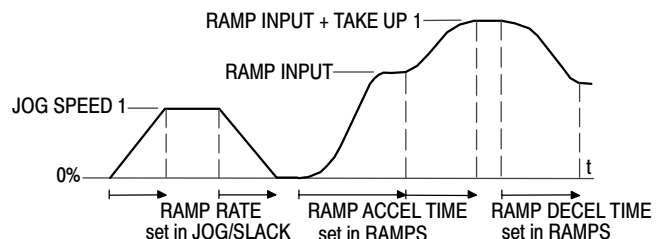

Menus

Allows selection of either the full menu structure, or a reduced menu structure. It also selects the language for the keypad display.

1

Full Menu
Language

1

4

Speed FBK Filter

Menus

Enabled	[37] Full Menu
0.000	[547] Speed FDBK Filter
English	[304] Language

Parameter Descriptions

FULL MENUS

When enabled, the full menu structure is displayed at the keypad.

Range: 0 : Disabled
1 : Enabled

LANGUAGE

Selects the display language. Other languages are available, please contact Baldor.

Range: 0 : English
1 : Other

SPEED FBK FILTER

A simple filter function that is applied to Speed Feedback to reduce ripple caused by encoders with low line count. A value of 0 disables the filter action. 1.00 is the maximum value. A typical value would be between 0.5 and 0.75.

Range: 0.000 to 1.000

Increasing the filter value may make the speed loop unstable.

The filter time constant " τ " in milliseconds is calculated as follows:

$$\tau = \frac{3.3}{\text{Log}_e\left(\frac{1}{\alpha}\right)}$$

Where α is the Speed FBK Filter value. $\alpha = 0.5$ indicates a filter time constant of 0.48 milliseconds, 0.8 to 14.7ms, and 0.9 to 31.2 ms.

OP Station

(Keypad) Local operation parameters are set using three menus.

1 **SETUP PARAMETERS**

2 **OP-STATION**

3 **SETUP**

Set Point
JOG Setpoint
Local Key Enable

1 **SETUP PARAMETERS**

2 **OP-STATION**

3 **LOCAL RAMP**

Ramp ACCEL Time
Ramp DECEL Time

1 **SETUP PARAMETERS**

2 **OP-STATION**

3 **START UP VALUES**

Setpoint
JOG Setpoint
Forward
Program
Local

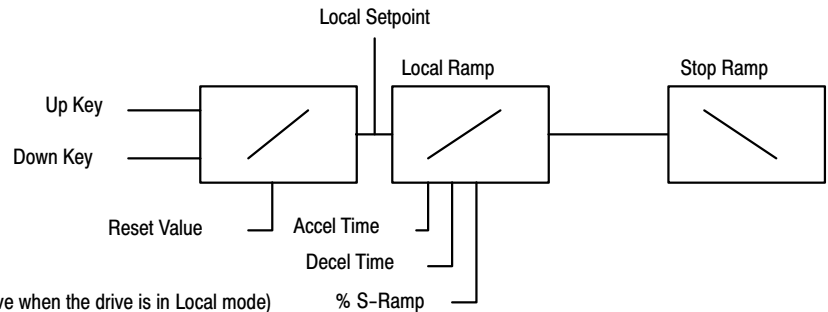

Note:

Local Setpoint (only active when the drive is in Local mode)

Parameter Descriptions

Local Key Enable

Enables the "L/R" on the keypad. This must be set true to allow the operator to select local and remote modes.

Range: 0 : False
1 : True

Setpoint

Actual value of local setpoint.

Range: 0.00 to 100.00 %

Jog Setpoint

Actual value of local jog setpoint.

Range: 0.00 to 100.00 %

RAMP ACCEL TIME

Acceleration time used in Local mode.

Range: 0.1 to 600.0
Seconds

RAMP DECEL TIME

Deceleration time used in Local mode.

Range: 0.1 to 600.0
Seconds

FORWARD (Initial FWD Direction)

Start-up mode of local direction on power-up. True = Forward.

Range: 0 : False
1 : True

LOCAL (Initial Local)

Start-up mode of keypad L/R key on power-up. True = Local mode.

Range: 0 : False
1 : True

Program (Initial Program)

Start-up mode of keypad PROG key on power-up. True = Program mode, to see the local setpoint.

Range: 0 : False
1 : True

Setpoint (Initial Setpoint)

Value of local setpoint on power-up.

Range: 0.00 to 100.00 %

JOG Setpoint (Initial Jog Setpoint)

Value of local jog setpoint on power up.

Range: 0.00 to 100.00 %

Password

This keypad menu activates or deactivates the password protection feature.

1 **PASSWORD**

Enter Password
By-Pass Password
Change Password

Parameter Descriptions

Enter Password

Factory Setting = 0x0000 (No Password Is Set).

Range: 0x0000 to 0xFFFF

BY-PASS PASSWORD

Reserved parameter.
Factory Setting = FALSE

Range: 0 : False
1 : True

CHANGE PASSWORD

Factory Setting = 0x0000 (no change).

Range: 0x0000 to 0xFFFF

PID This is a general purpose PID block which can be used for many closed loop control applications. PID feedback can be loadcell tension, dancer position or any other transducer feedback such as pressure, flow etc.

1 **SETUP PARAMETERS**

2 **SPECIAL BLOCKS**

3 **PID**

- PROP Gain
- INT Time CONST
- Derivative TC
- Positive Limit
- Negative Limit
- O/P Scaler (Trim)
- Input 1
- Input 2
- Ratio 1
- Ratio 2
- Divider 1
- Divider 2
- Enable
- INT Defeat
- Filter TC
- Mode
- MIN Profile Gain
- Profiled Gain

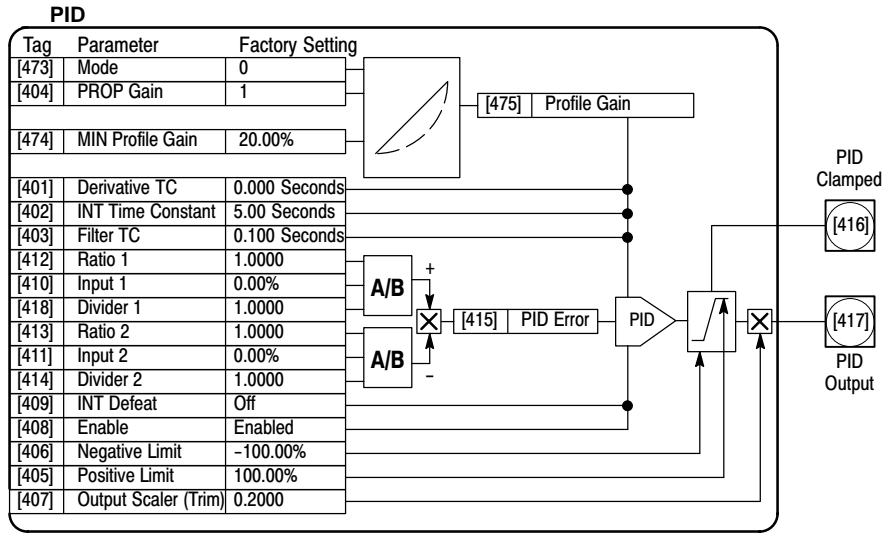

Parameter Descriptions

PID Output (Read in Diagnostics Parameters)
Refer to the diagnostics function block description.

Range: xxx.xx %

PID Clamped (Read in Diagnostics Parameters)
Refer to the diagnostics function block description.

Range: 0 : False
1 : True

PID Error (Read in Diagnostics Parameters)
Refer to the diagnostics function block description.

Range: xxx.xx %

PROP. Gain

This is a pure gain factor which shifts the whole Bode PID transfer function up or down leaving the time constants unaffected. A value of P = 10.0 means that, for an error of 5%, the proportional part (initial step) of the PID output will be:
 $10 \times [1 + (Td/Ti)] \times 5\%$, i.e. approx. 50% for $Td \ll Ti$.

Range: 0.0 to 100.0

INT. TIME CONST (SPD.INT.TIME)

The integrator time constant (Ti)

Range: 0.01 to 100.00
Seconds

DERIVATIVE TC

The differentiator time constant (Td). When Td = 0 the transfer function of the block becomes a P+I.

Range: 0.000 to 10.000
Seconds

Positive Limit

The upper limit of the pid algorithm.

Range: 0.00 to 105.00 %

Negative Limit

The lower limit of the PID algorithm.

Range: -105.00 to 0.00 %

Output Scaler (Trim) (Output Scaler Gain)

The ratio which the limited PID output is multiplied by in order to give the final PID Output. Normally this ratio would be between 0 and 1.

Range: -3.0000 to 3.0000

INPUT 1

This can be either a position/tension feedback or a reference/offset.

Range: -300.00 to 300.00 %

INPUT 2

This can be either a position/tension feedback or a reference/offset.

Range: -300.00 to 300.00 %

RATIO 1

The gain factor for Input 1 (Ratio 1).

Range: -3.0000 to 3.0000

RATIO 2

The gain factor for Input 2 (Ratio 2).

Range: -3.0000 to 3.0000

DIVIDER 1

This reduces (divides) Input 1 by a factor (Divider 1).

Range: -3.0000 to 3.0000

DIVIDER 2

This reduces (divides) Input 2 by a factor (Divider 2).

Range: -3.0000 to 3.0000

ENABLE

A digital input which resets the (total) PID Output as well as the integral term when false.

Range: 0 : Disabled
1 : Enabled

INT. DEFEAT

A digital input which resets the integral term when true. The block transfer function then becomes P+D only.

Range: 0 : Off
1 : On

PID Continued

Parameter Descriptions

FILTER T.C.

To attenuate high-frequency noise, a first order filter is added in conjunction with the differentiator. The ratio k of the Derivative Time Constant (Td) over the Filter Time Constant (Tf) (typically 4 or 5) determines the high-frequency lift of the transfer function. For Tf = 0 this filter is disabled.

Range: 0.000 to 10.000
Seconds

MODE

This determines the law which the profiler follows versus diameter.

For Mode = 0, Profiled Gain = constant = P.

For Mode = 1, Profiled Gain = A * (diameter - min diameter) + B.

For Mode = 2, Profiled Gain = A * (diameter - min diameter)² + B.

For Mode = 3, Profiled Gain = A * (diameter - min diameter)³ + B.

For Mode = 4, Profiled Gain = A * (diameter - min diameter)⁴ + B.

Range: 0 to 4

MIN PROFILE GAIN

This expresses the minimum gain required at min diameter (core) as a percentage of the (max) P gain at full diameter (100%).

Range: 0.00 to 100.00 %

PROFILED GAIN

The output of a profiler block which varies the gain versus diameter. This is primarily to be used with Speed Profiled Winders for compensation against varying diameter and therefore inertia. When MODE is not ZERO (see above) this overrides the P gain above.

Range: xxxx.x

Functional Description

The block diagram shows the internal structure of the PID block. PID is used to control the response of any closed loop system. It is used specifically in system applications involving the control of drives to allow zero steady state error between reference and feedback, together with good transient performance.

Proportional Gain (PROP. GAIN)

Adjusts the basic response of the closed loop control system. It is defined as the portion of the loop gain that is fed back to make the complete control loop stable. The PID error is multiplied by the proportional gain to produce an output.

Integral (INT. TIME CONST.)

The Integral term is used to give zero steady state error between the setpoint and feedback values of the PID. If the integral is set to a small value, this will cause an underdamped or unstable control system.

Derivative (DERIVATIVE TC)

Corrects certain types of control loop instability and therefore improves response. Helpful when heavy or large inertia rolls are being controlled. The derivative term has an associated filter to suppress high frequency signals.

Parameter values should be selected to achieve a critically damped response, which allows the mechanics to track as precisely as possible a step change on the setpoint.

Critically Damped Response

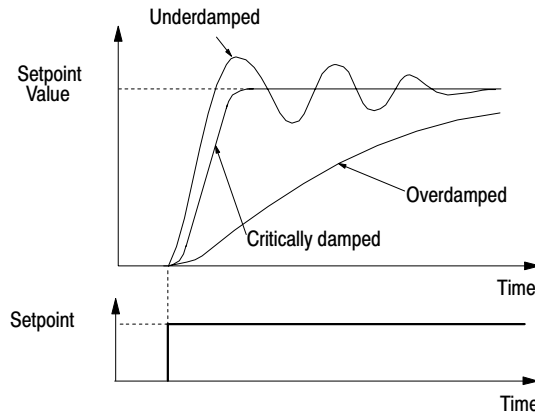

Raise/Lower Provides a motor operated potentiometer (MOP) feature. Raise input [261], when true, increases the output at the rate determined by increase rate [256]. Lower input [262] decreases the output as determined by decrease rate [257]. MIN value and MAX value limits the total change by the amounts set. The output is not preserved during power-down.

1 **SETUP PARAMETERS**

2 **RAISE/LOWER**

- Reset Value
- Increase Rate
- Decrease Rate
- Raise Input
- Lower Input
- MIN Value
- MAX Value
- External Reset

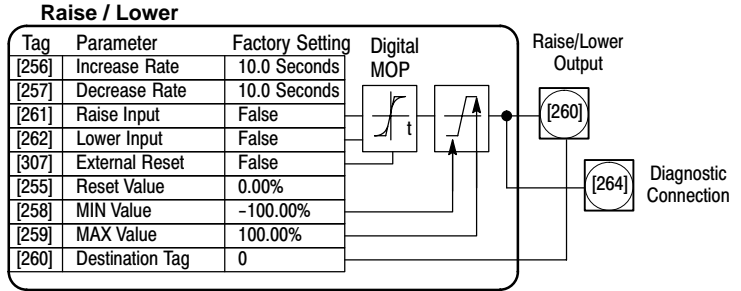

Parameter Descriptions

Raise/Lower Output (Read in Diagnostics Parameters)
Refer to the diagnostics function block description.

Range: xxx.xx %

Reset Value

This reset value is preloaded directly into the output when External Reset is True, or at power-up. It is clamped by min and max values.

Range: -300.00 to 300.00 %

Increase Rate

Rate of change of increasing output value.

Range: 0.1 to 600.0 Seconds

Decrease Rate

Rate of change of decreasing output value.

Range: 0.1 to 600.0 Seconds

Raise Input

Command to raise output.

Range: 0 : False
1 : True

Lower Input

Command to lower output.

Range: 0 : False
1 : True

MIN Value

Minimum ramp output clamp. This is a plain clamp, not a ramped "min speed" setting.

Range: -300.00 to 300.00 %

MAX Value

Maximum ramp output clamp.

Range: -300.00 to 300.00 %

External Reset

If External Reset = true, the output of the raise/lower block = the reset value.

Range: 0 : False
1 : True

Functional Description

These waveforms illustrate the raise/lower function. When External Reset is set true, the raise/lower output resets to reset value (default = 0.00%). When Raise Input is true, the output increases at increase rate. The output cannot exceed MAX Value. When Lower Input is true, the output is reduced at the decrease rate. The output cannot go below the MIN Value. Removing the raise or lower signal before the output reaches its maximum or minimum value leaves the output at its last value. Setting both raise input and lower input to true at the same time creates a ramp hold condition.

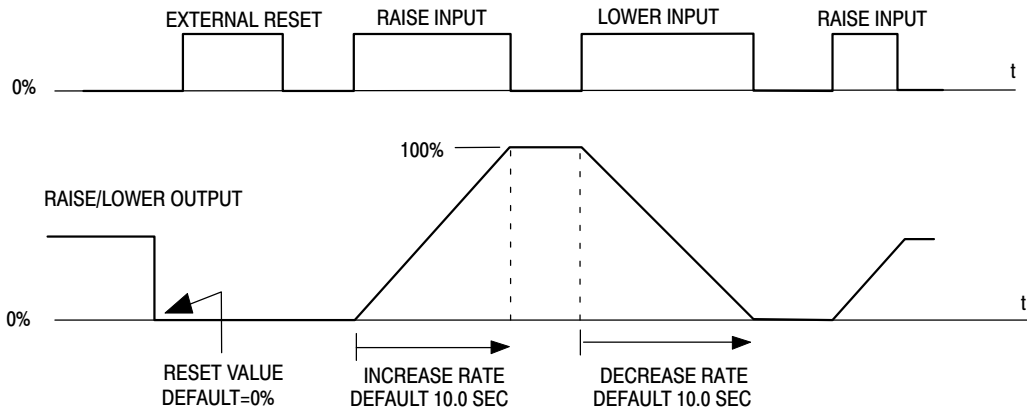

Ramps

This function block provides the facility to control the rate at which the control will respond to a changing setpoint.

1 **SETUP PARAMETERS**

2 **RAMPS**

Ramp ACCEL Time
Ramp DECEL Time
Constant ACCEL
Ramp Hold
% S-Ramp
Ramping Thresh
Auto Reset
External Reset
Reset Value
Reset Value
MIN Speed

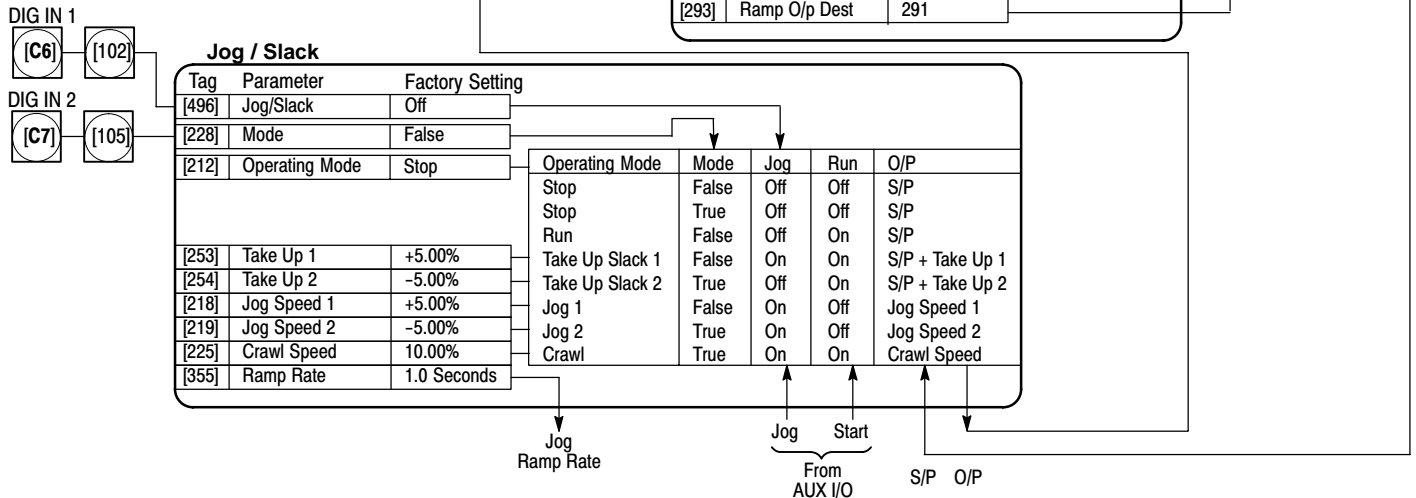

Parameter Descriptions

Ramp Output (Read in Diagnostics Parameters)
Refer to the diagnostics function block description.

Range: xxx.xx %

Ramping (Read in Diagnostics Parameters)
Refer to the diagnostics function block description.

Range: 0 : False
1 : True

Ramp Accel Time
Acceleration time (100% change)

Range: 0.1 to 600.0 Seconds

Ramp Decel Time
Deceleration time (100% change)

Range: 0.1 to 600.0 Seconds

Constant Accel
Reserved parameter.

Range: 0 : Disabled
1 : Enabled

Ramp Hold
While ON, the ramp output is held at its last value. This is overridden by Ramp Reset.

Range: 0 : Off
1 : On

Ramp Input
Ramp input tag.

Range: -105.00 to 105.00 %

% S-Ramp
Percentage of ramp with S-shaped rate of change. A value of zero is equivalent to a linear ramp. Changing this value affects the ramp times.

Range: 0.00 to 100.00 %

Ramping Thresh.
Ramping flag threshold level. The threshold is used to detect whether the ramp is active.

Range: 0.00 to 100.00 %

Auto Reset
If true, then the ramp is reset whenever System Reset is true, that is each time the speed/current loop is unquenched. (System Reset [374] is an internal flag that is set true for one cycle after the speed/current loop is enabled, i.e. every time the drive is started).

Range: 0 : Disabled
1 : Enabled

External Reset
If true, then the ramp is held in reset. External reset does not depend on auto reset for its operation.

Range: 0 : Disabled
1 : Enabled

Ramps Continued

Parameter Descriptions

Reset Value

This value is loaded into the output when Ramp Reset is true, or at power-up. To catch a spinning load smoothly ('bumpless transfer'), connect Speed Feedback [62] (source) to Reset Value [422] (destination).

Range: -300.00 to 300.00 %

MIN. Speed

The minimum speed clamp is fully bi-directional and operates with a 0.5% hysteresis. This clamp operates on the input to the ramp and it can therefore be overridden by the Reset Value (as far as the ramp output is concerned).

Range: 0.00 to 100.00 %

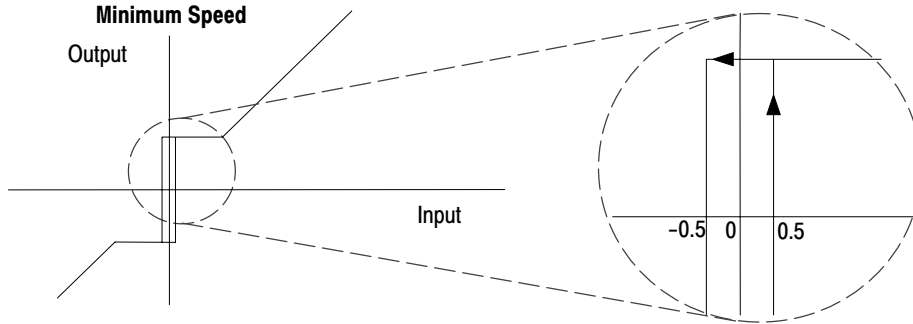

Functional Description

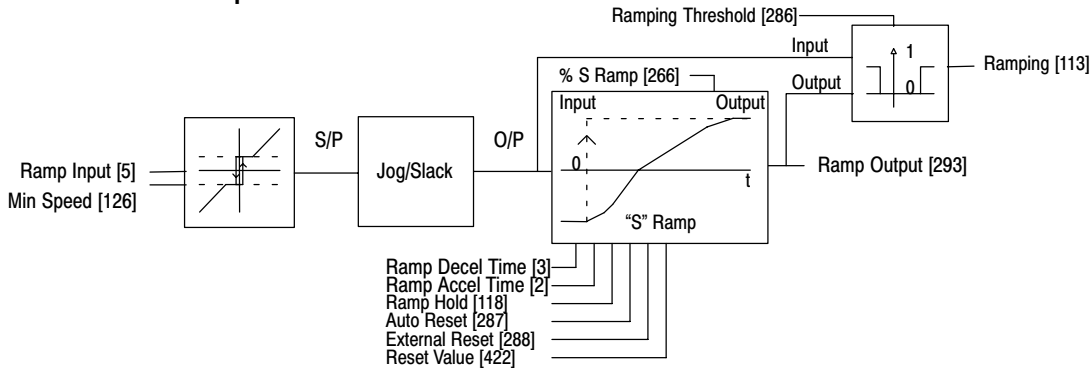

Acceleration / Deceleration Rates

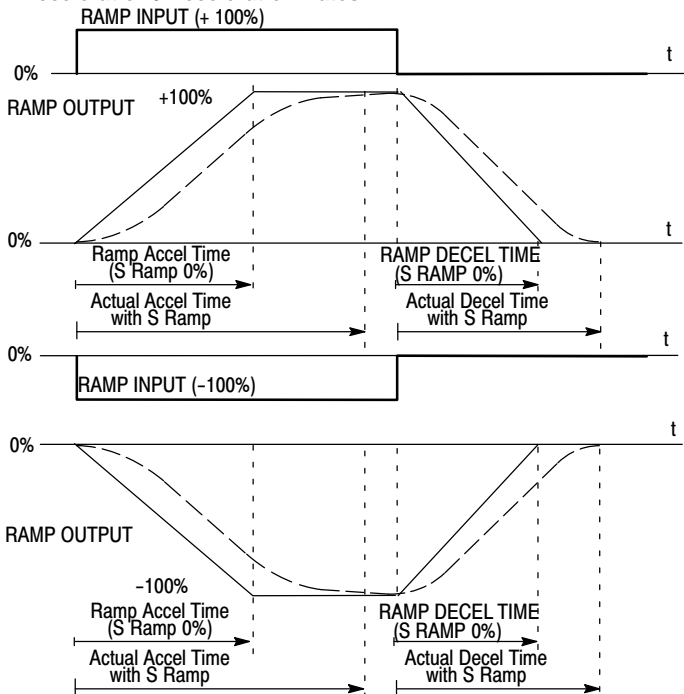

Ramp Hold

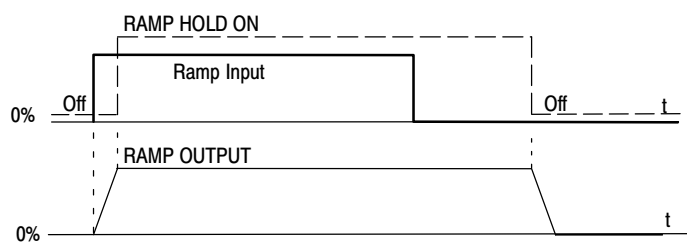

Ramp operation occurs when a ramp input is present. When Digital Input 2 is ON, Ramp Hold stops the ramp output from changing. Even when the ramp input signal is removed, Ramp Hold keeps the ramp output from changing. Once Ramp Hold is off, the ramp resumes.

Ramps Continued
Minimum Speed

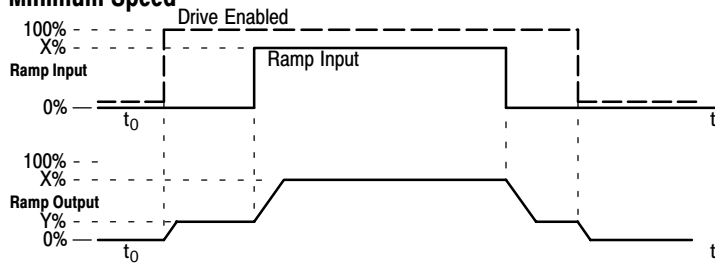

This figure shows the effect of setting MIN. Speed above 0.00%. When the drive is enabled, the ramp output cannot decrease below the MIN. Speed value. Note the ramp rates are used when changing the output from minimum speed to zero speed. Notice also that in this example the ramp output only increases to X% since the ramp input signal is limited to X%.

Auto Reset

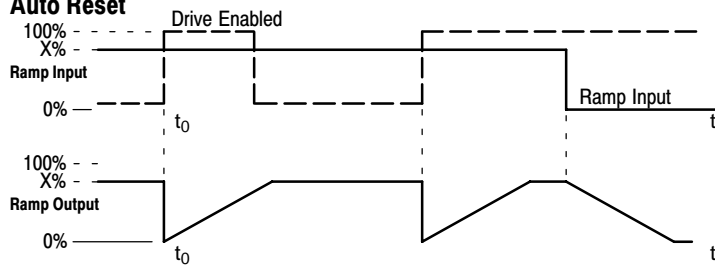

With Auto Reset enabled, the ramp output resets to reset value each time the drive is enabled. In this example, reset value is 0.00%. It does not reset if the drive is disabled.

External Reset

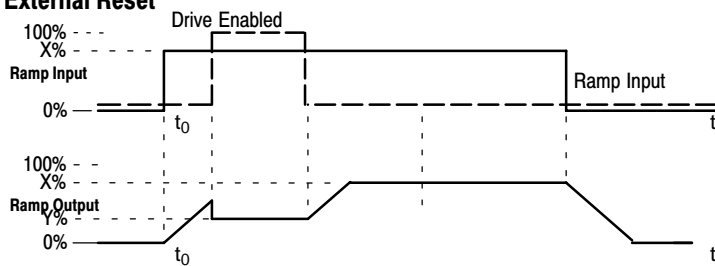

The ramp input is set to X% at time t_0 . The ramp output will increase at the ramp rate. While external reset is enabled, the ramp output resets to reset value. When external reset is disabled, the ramp output continues to follow input signal.

Setpoint Sum 1 Setpoint Sum 1 allows the summing and scaling of three analog inputs to produce SPT. Sum Output [294].
 Note: This block is ignored by the drive unless [294] is connected to a nonzero destination tag.

Input 0 and Input 1 have individual ratio and divider scalars, and signs. Input 1 has an additional deadband function set by Deadband Width. When the input is within the deadband, the output clamps to zero to ignore any noise. This parameter is useful when digital setpoints are used (for example from a 5703, serial communications, or the Raise Lower function block). The inputs have symmetrical limits set by Limit. Input 2 has no scaling or limits. The output after Input 0, Input 1, and Input 2 are summed is also clamped by Limit before producing SPT. Sum Output.

1 **SETUP PARAMETERS**

2 **SETPOINT SUM 1**

- Ratio 1
- Ratio 0
- Sign 1
- Sign 0
- Divider 1
- Divider 0
- Deadband Width
- Limit
- Input 2
- Input 1
- Input 0

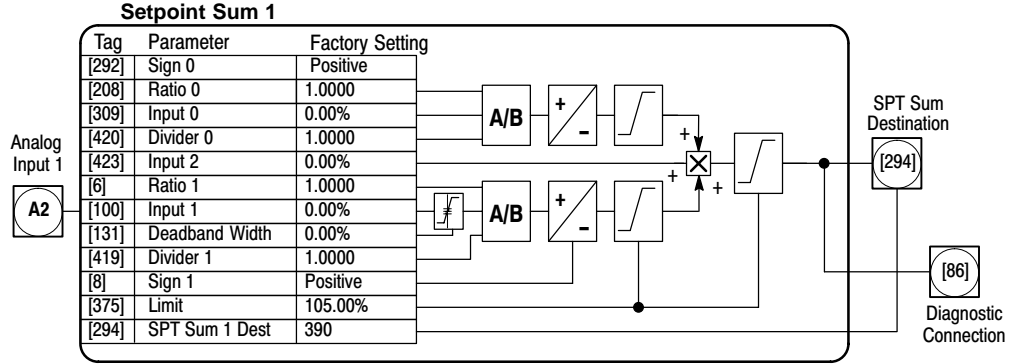

Parameter Descriptions

SPT. Sum 1 Destination [294] (Set in Configure I/O::Block Diagram Parameters)
 Refer to the diagnostics function block description.

Range: 0 to 549

SPT. Sum Output [86] (Read in Diagnostics Parameters)
 Refer to the diagnostics function block description.

Range: R/O

Ratio 1
 Analog input 1 scaling.

Range: -3.0000 to 3.0000

Ratio 0
 Input 0 scaling.

Range: -3.0000 to 3.0000

Sign 1
 Analog input 1 polarity.

Range: 0 : Negative
 1 : Positive

Sign 0
 Input 0 polarity.

Range: 0 : Negative
 1 : Positive

Divider 1
 Analog input 1 scaling. Dividing by 0 (zero) results in a zero output.

Range: -3.0000 to 3.0000

Divider 0
 Input 0 scaling. Dividing by 0 (zero) results in a zero output.

Range: -3.0000 to 3.0000

Deadband Width
 Analog input 1 deadband width. When Input 1 is within the deadband, the output clamps to zero to ignore any noise.

Range: 0.00 to 100.00 % (h)

LIMIT
 The Setpoint Sum 1 programmable limit is symmetrical and has the range of 0.00% to 200.00%. The limit is applied both to the intermediate results of the ratio calculation and the total output.

Range: 0 : False
 1 : True

INPUT 2
 Input 2 value. The factory settings do not connect this input to any analog input.

Range: -200.00 to 200.00 %

INPUT 1
 Input 1 value. The factory settings connects this input to Analog Input 1 (A2).

Range: -200.00 to 200.00 %

INPUT 0
 Input 0 value. The factory settings do not connect this input to any analog input.

Range: -200.00 to 200.00 %

Speed Loop

Speed loop selects the speed feedback source and tunes the speed loop PI to produce a current demand. The parameters are set in several menus, some parameters can be set in multiple menus. Speed FBK Select determines the source of the speed feedback signal. The default, Arm Volts FBK, uses internal circuitry to derive speed feedback. The other selections require external devices to provide the feedback signal. Speed Demand is summed algebraically with Speed Feedback to yield Speed Error. When the drive is enabled, Speed Error is controlled by the PI loop. Proportional and integral values are set in the Advanced::Adaption block. The resulting current demand signal is sent to the Current Loop block and to the Advanced::Zero SPD. Quench block.

- | | | | | | | | | | |
|---|------------------|---|------------------|---|------------------|-------------------|------------------|---|------------------|
| 1 | SETUP PARAMETERS | 1 | SETUP PARAMETERS | 1 | SETUP PARAMETERS | 1 | SETUP PARAMETERS | 1 | SETUP PARAMETERS |
| 2 | SPEED LOOP | 2 | SPEED LOOP | 2 | SPEED LOOP | 2 | SPEED LOOP | 2 | SPEED LOOP |
| | Speed PROP Gain | 3 | SETPOINTS | 3 | ADVANCED | 3 | ADVANCED | 3 | ADVANCED |
| | Speed INT Time | | Setpoint 1 | | 4 | ADAPTION | | 4 | ZERO SPD QUENCH |
| | INT Defeat | | Sign 2 (A3) | | | Mode | | | Zero SPD Level |
| | Encoder Sign | | Ratio 2 (A3) | | | Speed BRK1 (Low) | | | Zero IAD Level |
| | Speed FBK Select | | Setpoint 3 | | | Speed BRK2 (High) | | | |
| | Speed FBK Filter | | Setpoint 4 | | | PROP Gain | | | |
| 1 | CONFIGURE DRIVE | | MAX Demand | | | | | | |
| | Speed FBK Select | | MIN Demand | | | | | | |
| | Encoder Sign | | | | | | | | |
| | Speed INT Time | | | | | | | | |
| | Speed PROP Gain | | | | | | | | |

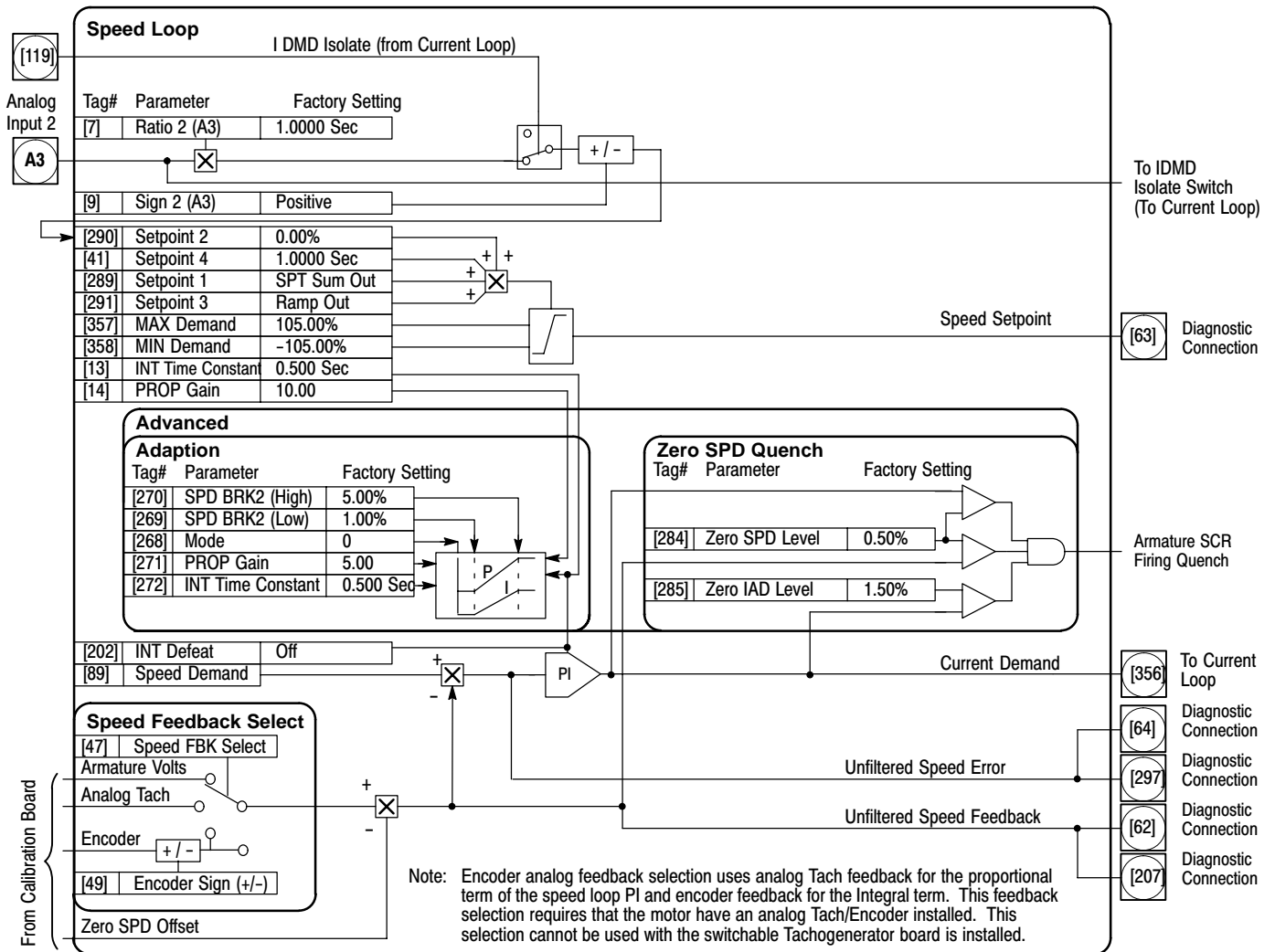

Speed Loop Continued

Parameter Descriptions

Speed Loop Output SPD Loop Output (Read in Diagnostics Parameters) Output from Speed Loop PI.	Range: xxx.xx %
Speed Feedback (Read in Diagnostics Parameters) The speed feedback value from the source chosen by SPEED FBK SEL.	Range: xxx.xx %
Speed Setpoint (Read in Diagnostics Parameters) Speed loop total setpoint including the ramp output before the ramp-to-zero function.	Range: xxx.xx %
Speed Error (Read in Diagnostics Parameters) Speed loop error.	Range: xxx.xx %
Speed PROP. Gain (Can be set in Speed Loop or Configure Drive.) Speed loop Pi proportional gain adjustment.	Range: 0.00 to 200.00
Speed INT. Time (Can be set in Speed Loop or Configure Drive.) Speed loop PI integral gain adjustment.	Range: 0.001 to 30.000 Seconds
INT. DEFEAT Inhibits the integral part of the speed loop PI to give proportional control only.	Range: 0 : Off 1 : On
Encoder Sign (Can be set in Speed Loop or Configure Drive.) Since the encoder feedback cannot be reversed electrically, the signal polarity can be reversed by the control software.	Range: 0 : Negative 1 : Positive
Speed FBK Select (Can be set in Speed Loop or Configure Drive.) Four options are available: 0 : ARM Volts FBK 1 : Analog TACH 2 : Encoder 3 : Encoder/Analog	Range: 0 to 3
Setpoint 1 Speed Setpoint 1.	Range: -105.00 to 105.00 %
Sign 2 (A3) Speed Setpoint 2 Sign.	Range: 0 : Negative 1 : Positive
Parameter Descriptions	
Ratio 2 (A3) Speed Setpoint 2 Ratio.	Range: -3.0000 to 3.0000
Setpoint 2 (A3) This is a fixed (non-configurable) input. This setpoint is scanned synchronously with the current loop .	Range: xxx.xx %
Setpoint 3 Speed Setpoint 3.	Range: -105.00 to 105.00 %
Setpoint 4 Speed Setpoint 4.	Range: -105.00 to 105.00 %
MAX Demand Sets the maximum input to the speed loop. It is clamped at 105% to allow for overshoot in the external loops.	Range: 0.00 to 105.00 %
MIN Demand Sets the minimum input to the speed loop.	Range: -105.00 to 105.00 %
I Gain in Ramp	Range:
POS Loop P Gain	Range:
Zero SPD Level	Range:
Zero IAD Level	Range:

Functional Description

Speed Loop PI Output – The PI output is available for connection using tag no. 356. This point is before the I Limit clamps and the summing of the additional current demand. This tag is not visible at the keypad.

Speed Loop PI with Current Demand Isolate – The speed loop output is still valid (active) with the I DMD. Isolate parameter enabled.

1. The speed loop is reset by unquenching the speed loop/current loop.
2. I DMD. ISOLATE is overridden by Program Stop (B8) or Normal Stop (C3).
3. The speed loop PI holds the integral term as soon as the PI output reaches current limit. This is true even in Current Demand Isolate mode where it may interfere depending on the way the speed PI is used. At the present time, this feature cannot be suppressed.

105% Speed Demands – The speed demand clamping allows the speed setpoint to reach 105%. This applies only to the final summing junction immediately before the speed loop and also to the Setpoint Sum 1 output. Individual speed setpoints are still clamped to 100%.

Speed Loop Continued

Advanced This function block is shown in Speed Loop

Adaption Adjusts speed loop gain scheduling.

Zero SPD Quench Similar to Standstill logic (i.e. keeps the contactor in but motor current drops to zero) except the speed loop stays enabled and will cause the current loop to unquench very quickly.

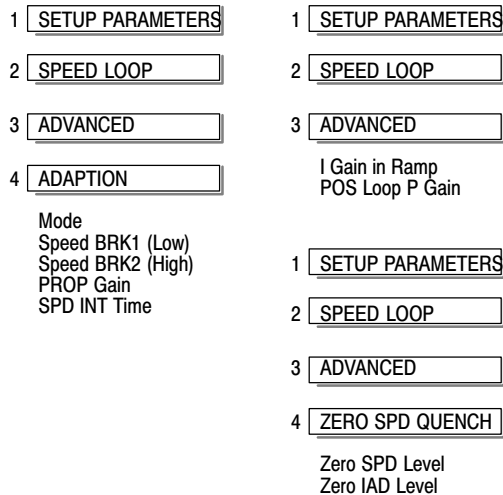

Parameter Descriptions

Mode

- 0 – Disabled
- 1 – Speed Feedback Dependent
- 2 – Speed Error Dependent
- 3 – Current Demand Dependent

Range: 0 to 3

SPD BRK 1 (Low)

If Mode = 1 Then BRK–points correspond to speed feedback.
 If Mode = 2 Then BRK–points correspond to speed error.
 If Mode = 3 Then BRK–points correspond to current demand.

Range: 0.00 to 100.00 %

SPD BRK 2 (High)

Above SPD BRK 2 (HIGH) the normal gains (as per main menu above) prevail. Between the two breakpoints, a linear variation of the gains is implemented.

Range: 0.00 to 100.00 %

PROP. Gain

Prop gain used below SPD BRK 1 (LOW)

Range: 0.00 to 200.00

SPD INT Time

Integral time constant used below SPD BRK 1 (LOW)

Range: 0.001 to 30.000
Seconds

I Gain IN Ramp

While the Ramping flag (Tag [113]) is true the integral gain is scaled by I GAIN IN RAMP. This can be used to help prevent integral windup while the drive is ramping (particularly with high inertia loads).

Range: 0.0000 to 2.0000

POS. LOOP P GAIN

Reserved parameter.

Range: –200.00 to 200.00 %

Zero SPD. Level

Sets the threshold of speed feedback below which Zero Speed Quench is active.

Range: 0.00 to 200.00 %

Zero IAD Level

Sets the threshold of current feedback below which Zero Speed Quench is active.

Range: 0.00 to 200.00 %

Standstill

Standstill logic is used to inhibit rotation during Zero Speed demand. If the drive is below the zero speed threshold [12] and Standstill Logic [11] is enabled, the speed and current loops are quenched to prevent shaft oscillation around zero speed. Standstill Logic is useful in maintaining absolute zero speed but can cause problems in web handling applications using tension feedback. At zero speed, the SCR's turn off allowing web tension to pull the driven roll in reverse. When the drive no longer senses zero speed, the SCR's turn on causing forward rotation and regulate tension. An oscillation condition can result as the drive SCR's turn on and off trying to maintain a fixed position. A "not at standstill" signal is sent to the drive enable logic.

When Speed Feedback is less than Zero Threshold, the At Zero Speed output is On. At Zero Setpoint is on when Speed Setpoint is less than Zero Threshold. When both At Zero Speed and At Zero Setpoint are on, At Standstill is on to indicate the motor has stopped.

When Standstill Logic is enabled, the SCR firing circuits are disabled, the main contactor remains energized and the Run Led stays on when the drive is at standstill. The drive remains in this state until standstill drops out (the speed setpoint or speed feedback increase above the zero threshold value).

1 SETUP PARAMETERS

2 STANDSTILL

Standstill Logic
Zero Threshold
Source Tag

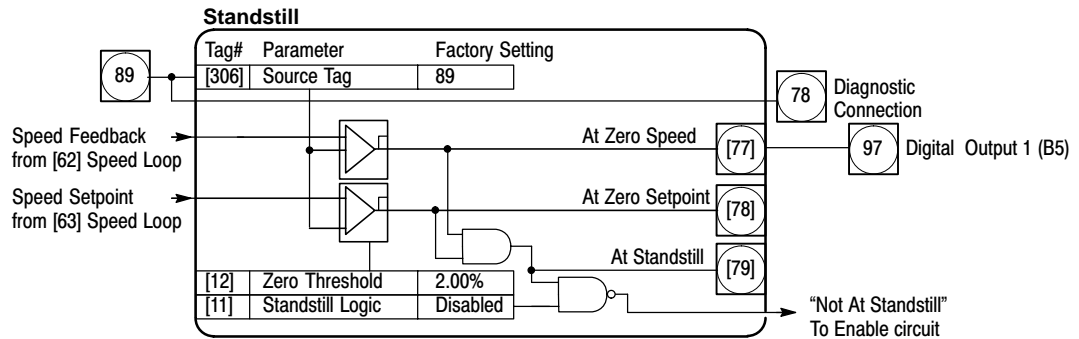

Parameter Descriptions

AT Zero Setpoint (Read in Diagnostics Parameters)
At zero speed demand.

Range: 0 : False
1 : True

AT Zero Speed (Read in Diagnostics Parameters)
At zero speed feedback.

Range: 0 : False
1 : True

AT Standstill (Read in Diagnostics Parameters)
At zero speed and zero setpoint.

Range: 0 : False
1 : True

Source Tag (Zero Setpoint)
Reserved parameter.

Range: 0 to 549

Standstill Logic

If true, the control is quenched (although the contactor remains in) when the speed feedback and speed setpoint values are less than zero threshold.

Range: 0 : Disabled
1 : Enabled

Zero Threshold

Threshold level which defines zero setpoint and zero speed diagnostic outputs and also controls the zero speed relay output.

Range: 0.00 to 100.00 %

Functional Description

Standstill logic inhibits the controller at zero setpoint and zero speed, i.e. at standstill. The main contactor remains in and the Run LED remains on.

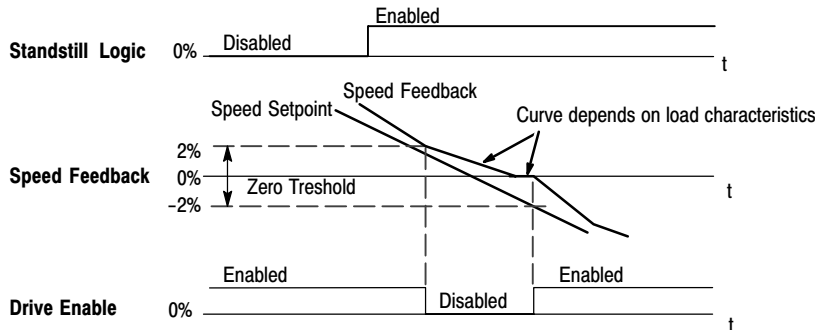

Stop Rates

Sets the stop method parameters for the control. A normal stop occurs when the Run signal is removed from terminal C3. It ramps the speed demand to zero at a rate set by Stop Time. Series 29 Non-regenerative drives will stop no faster than the coast stop rate. Series 30 Regenerative drives use Stop Time to set the duration of the stop. After the stop, the contactor de-energizes and the drive disables. The Stop Limit timer starts when C3 goes to zero volts. If the drive speed has not reached Stop Zero Speed within the Stop Limit time, the contactor de-energizes and the drive disables.

During normal stops, Contactor Delay delays de-energizing the contactor after the motor reaches zero speed. When Stop Zero Speed is set greater than 0.25%, the drive disables during the contactor delay. Below 0.25%, the drive disables after the contactor delay. This is useful when using the jog function to prevent multiple operations of the contactor. Contactor Delay is overridden when terminal C4 is at zero volts.

Program Stop provides a controlled fast stop using regenerative drives. The stop time is set by Program Stop Time. The timer starts when terminal B8 goes to zero volts. When the drive reaches Stop Zero Speed, the contactor de-energizes and the drive disables. Program Stop Limit sets the maximum time the program stop can take before the contactor de-energizes and the drive disables.

Prog Stop I Lim sets the current limit (current loop) during a program stop. Other current limits can override it.

1 SETUP PARAMETERS

2 STOP RATES

Stop Time
Stop Limit
Contactor Delay
PROG Stop Time
PROG Stop Limit
PROG Stop I LIM
Stop Zero Speed

Program Stop is true when terminal B8 is Low (Status LED Off).

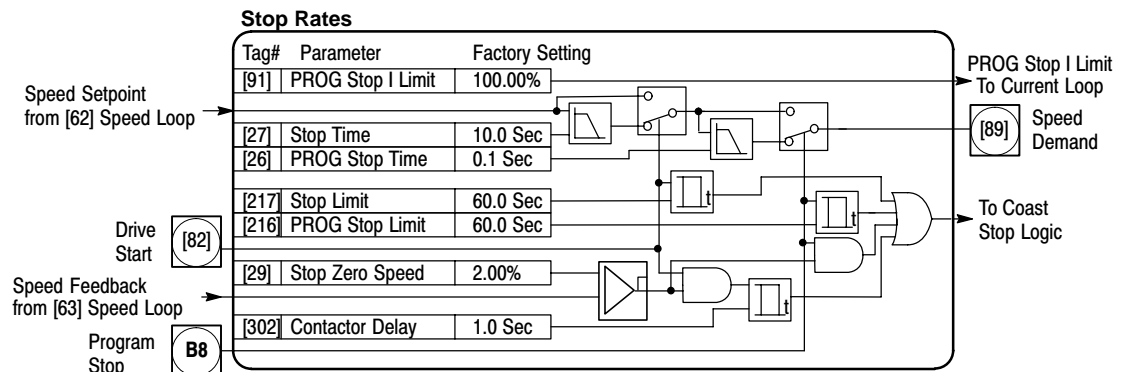

Parameter Descriptions

Speed Demand (Read in Diagnostics Parameters)

Speed loop total setpoint after the ramp-to-zero block.

Range: xxx.xx %

Program Stop (Read in Diagnostics Parameters)

State of Program Stop (Terminal B8). When B8 is at 24V, then Program Stop is false and the Program Stop front panel LED is also on.

Range: 0 : False
1 : True

Stop Time

Time to reach zero speed from 100% set speed in normal stop mode (C3 Off).

Range: 0.1 to 600.0
Seconds

Stop Limit

Delay time limit to allow normal stop action (regenerative braking) to achieve zero speed before drive quench and coast stop. The timer is triggered by Start command (C3) going low.

Range: 0.0 to 600.0
Seconds

Contactor Delay

This defines the time between the drive reaching Stop Zero Speed (Tag [29]) and the contactor being opened. This is particularly useful during the jog cycle to prevent multiple operations of the main contactor.

Range: 0.1 to 600.0
Seconds

If Stop Zero Speed is $\geq 0.25\%$, the drive will be quenched during the contactor delay time. The Contactor delay is overridden by Enable (C4).

Maintain zero speed during contactor delay.

If Stop Zero Speed is $< 0.25\%$, the drive is not quenched until after the Contactor Delay time.

PROG Stop Time

Time to reach zero speed from 100% set speed in program stop mode (B8 OFF).

Range: 0.1 to 600.0
Seconds

PROG Stop Limit

Delay time limit to allow program stop action (regenerative braking) to achieve zero speed before drive quench and coast stop. The timer is triggered by program stop command (B8) going low.

Range: 0.0 to 600.0
Seconds

PROG Stop I LIM

Main current limit level in program stop mode assuming current limit not overridden by I Profile or Inverse Time limits.

Range:

Stop Zero Speed

Zero speed level in program stop and normal stop modes at which the contactor delay timer starts timing out. At the end of this delay the contactor is de-energized.

Range: 0.00 to 100.00 %

Stop Rates Continued

Functional Description

Stop Hierarchy

Coast Stop – Terminal B9

- Disables the drive and opens the contactor using the pilot output

Enable – Terminal C4

- Suspends and resets the control loops

Program Stop – Terminal B8

- Independent ramp time
- Stop Timer
- Independent current limit may be greater than normal current limit
- Independent zero speed

Normal Run/Stop – Terminal C3

- Independent ramp time
- Contactor Delay

Note: The Control's reaction to commands is defined by a state machine. This determines which commands provide the demanded action, and in which sequence. Consequently, Coast Stop and Program Stop must be false (the Control is not in Coast or Program mode), before a Run signal is applied. Otherwise the control assumes a stop mode and remains disabled.

Normal Stop Sequence

Stop Zero Speed settings less than 0.25% allow the control to remain enabled for the Contactor Delay Time after reaching Stop Zero Speed. This is useful for Jog applications.

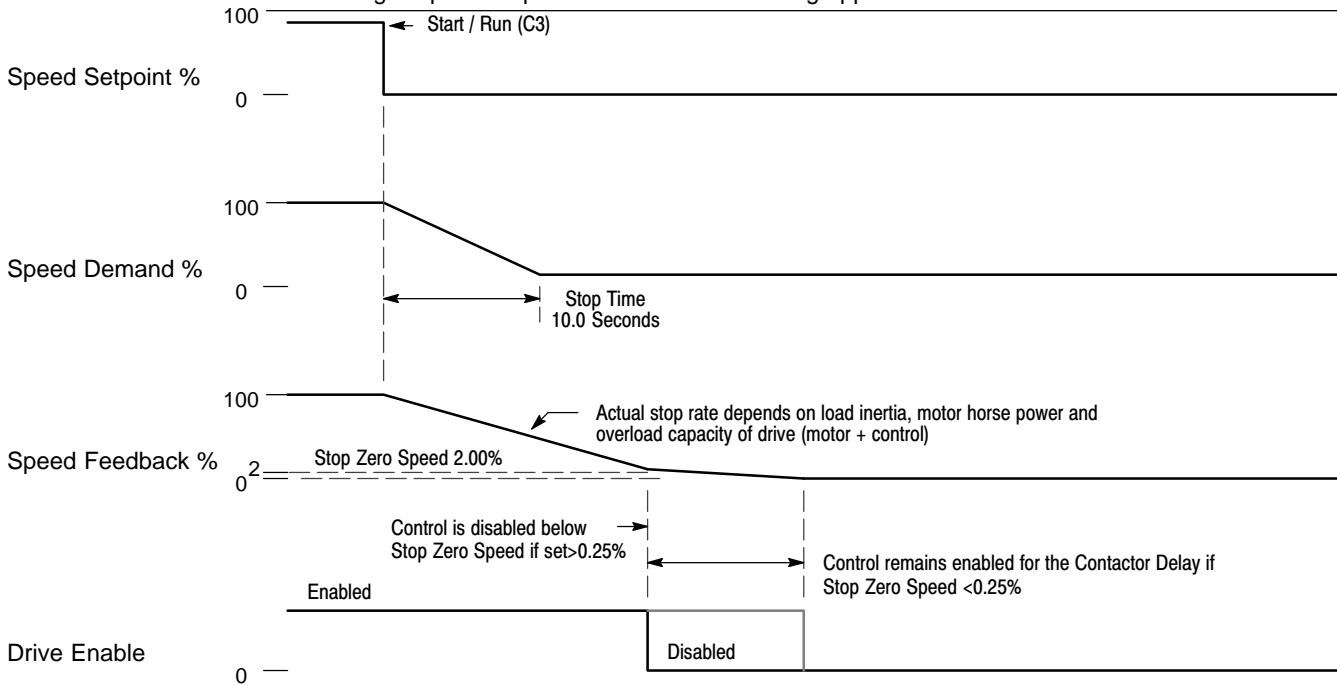

Stop Rates Continued

Time Out During a Normal Stop

When a normal stop takes longer than the Stop Limit time, the control disables and the contactor is de-energized.

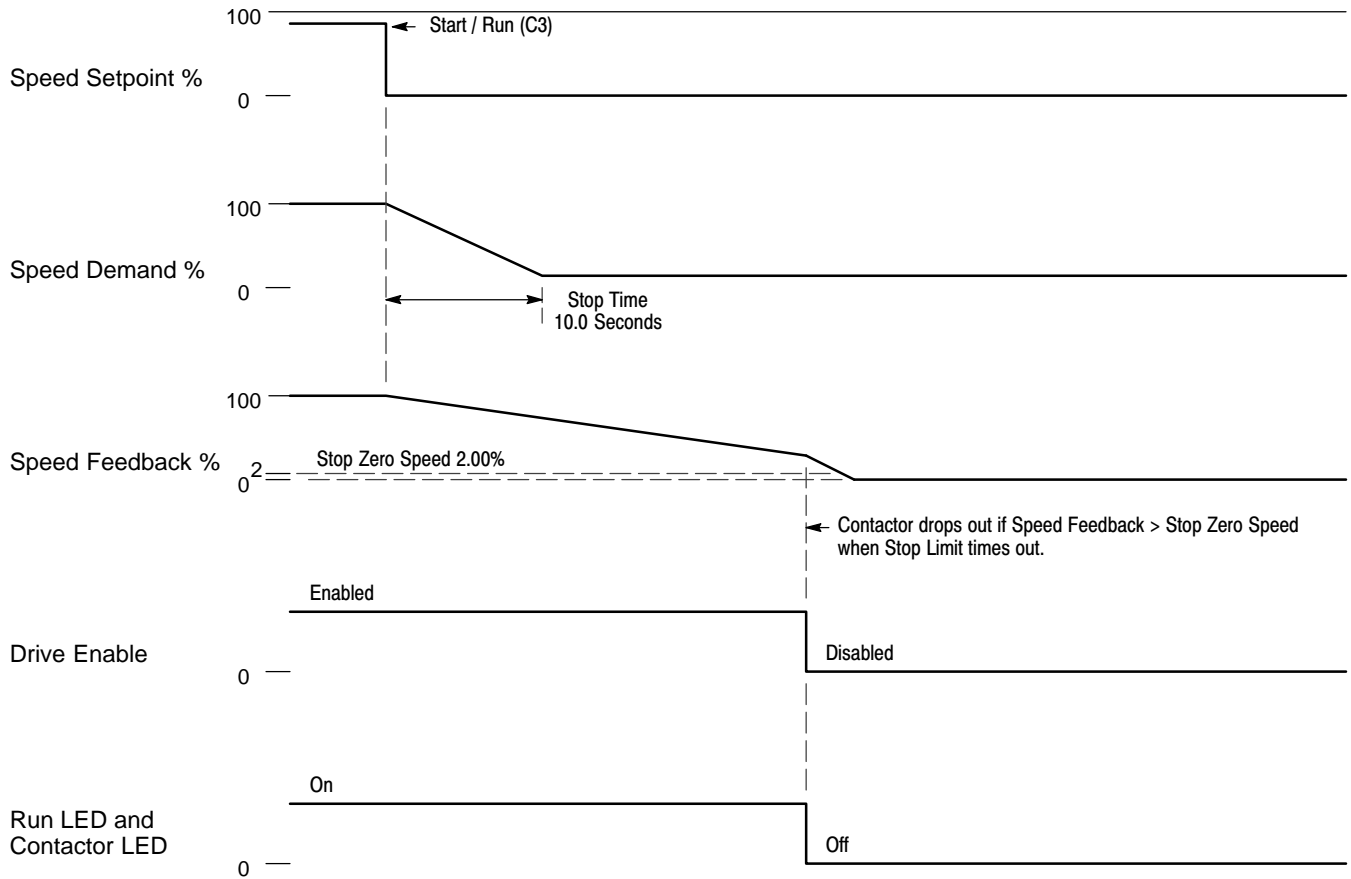

Stop Rates Continued

Normal Program Stop Sequence

Program Stop is a latched operation. When a Program Stop command is received (B8 goes to zero volts), the stop continues even if 24 volts is restored at terminal B8.

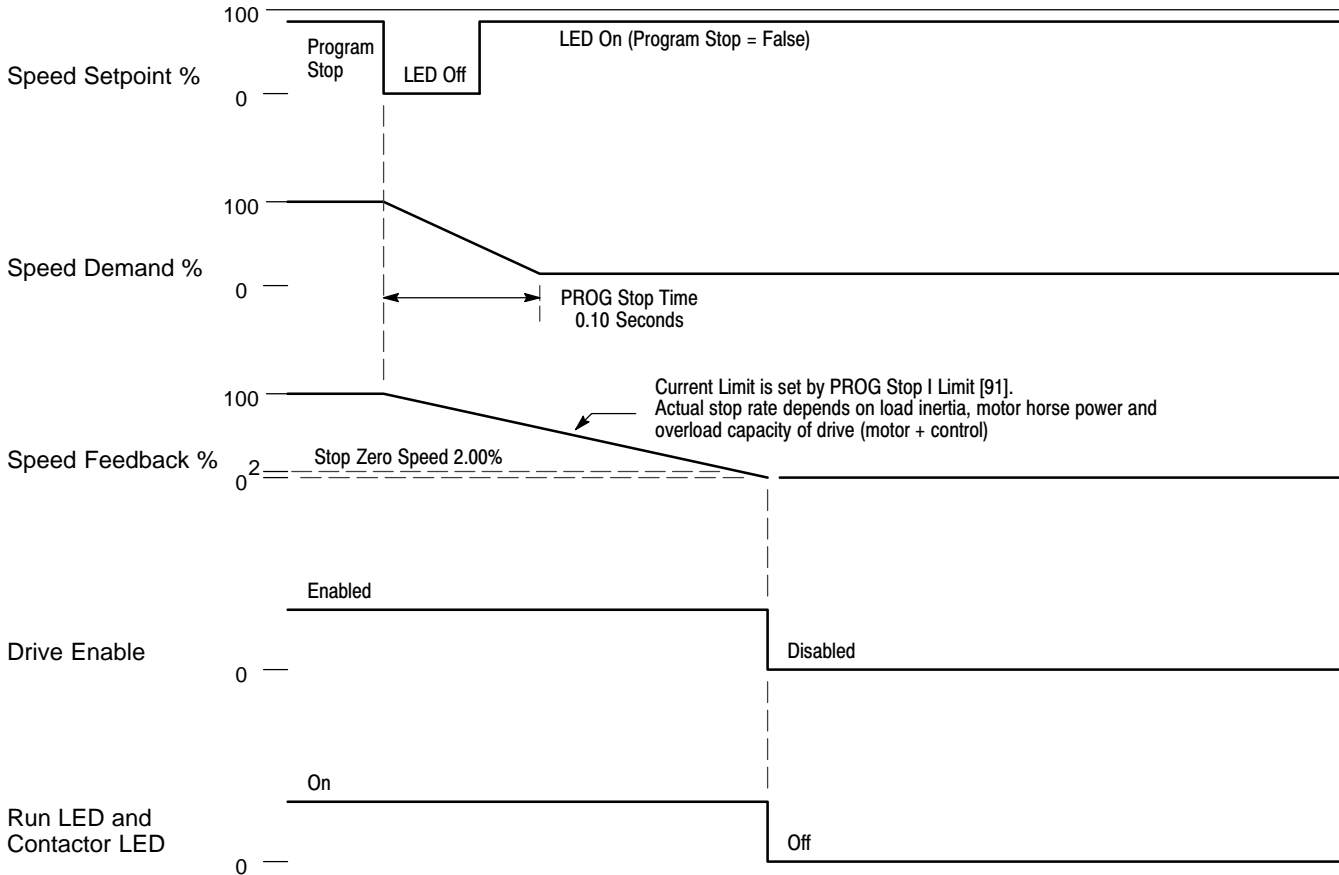

Stop Rates Continued

Time Out During a Normal Program Stop

The time out operation is the same for both a normal stop and a program stop.

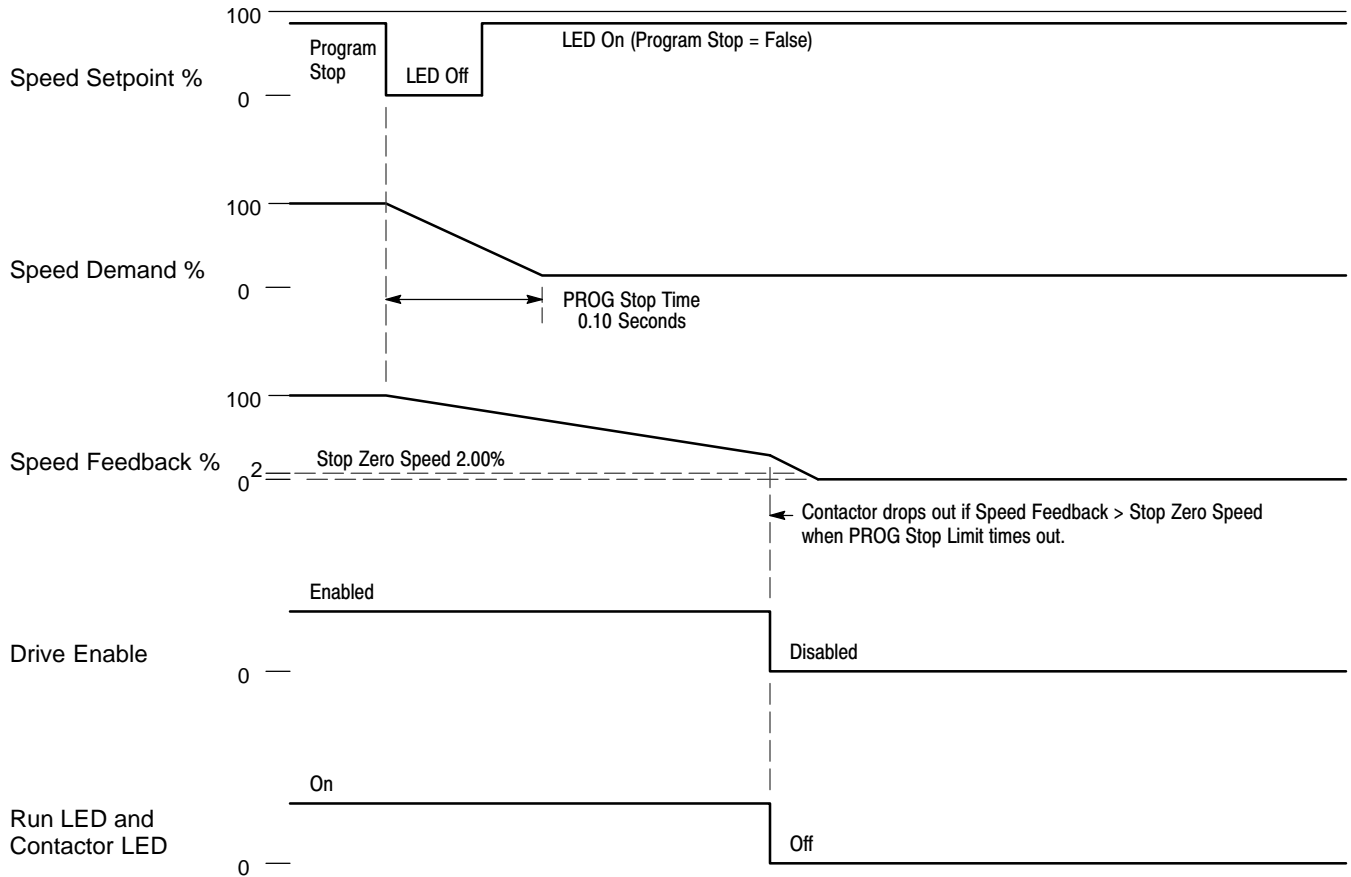

System Port P3 The System Port (P3) is a non-isolated RS232 serial communications port. The port is used off-line (while the drive is stopped) for transferring and saving drive configuration files using a personal computer (PC) running a serial communications program, or online (while running) with the Peer-to-Peer Communications control. You can also use the P3 port to transfer configuration files with a PC running Workbench D software. Three menus are used to configure the serial port.

System Port P3 This menu sets parameters for transferring data to and from a PC.

P3 Setup This menu sets communication parameters for System Port P3.

BISYNCH SUPPORT This menu sets parameters to support the BISYNCH protocol.

5703 SUPPORT Sets parameters for the optional 5703 board (see 5703 Support).

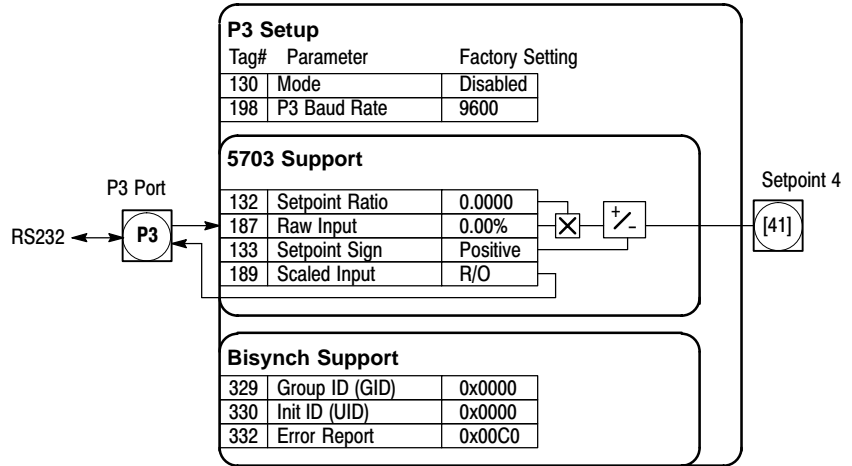
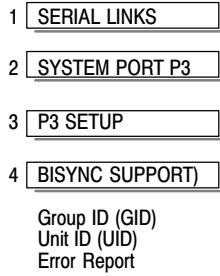
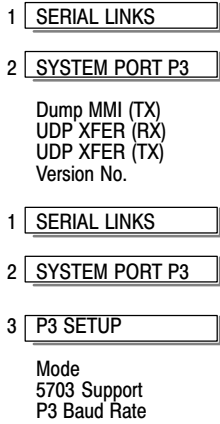

Parameter Descriptions

MODE Four options are available: Range: 0 to 3
 0 : Disabled
 1 : 5703 Master
 2 : 5703 Slave
 3 : CELite (EIAASCII)

P3 BAUD RATE Four options are available: Range: 9600
 Only works at 9600

Setpoint Ratio Range: -3.0000 to 3.0000
 Input scaling ratio for [187].

Raw Input Range: xxx.xx%
 Value written to the control from the P3 port (input data).

Setpoint Sign Range: 0:Negative
1:Positive
 Invert/non-invert of Raw input [187]

Scaled Input Range: xxx.xx%
 Value written by the control to the P3 port (output data).

GROUP ID Range: 0x0000 to 0x0007
 The Baldor protocol group identity address.

UNIT ID Range: 0x0000 to 0x000F
 The Baldor protocol unit identity address.

ERROR REPORT Range: 0x0000 to 0xFFFF
 Displays the last error as a hexadecimal code. Writing any value to this parameter will set the value to >00C0 (No Error). Refer to Section 8 "Serial Communications" – Reference for a list of codes.

System Port P3 Continued

Communication Port Setup

For UDP data and text file transfers, set the host computer communication port settings as follows:

- 9600 Baud 8 bits
- 1 Stop bit
- XON/XOFF handshaking
- NO parity UDP transfer procedure

Note: Set the P3 Baud Rate to match the PC's COM port baud rate (9600 is recommended).

P3 Port Connector	P3 Pin No.	Signal Name	DB9 Pin No.		DB25 Pin No.	
			Female	Male	Female	Male
	1	0VDC	5	5	7	7
	2	24VDC	No Connection	No Connection	No Connection	No Connection
	3	T _x	2	3	2	3
	4	R _x	3	2	3	2

Download (DUMP File From P3)

This procedure is used to collect information that fully documents all the control's settings in an ASCII text file. You can print the file or store it for future use (troubleshooting etc.).

Note: This procedure transfers the drive's current settings (in memory), not the settings stored in EEPROM.

1. Connect one end of the P3 cable to the P3 port and the other end to the PC's COM port.
2. Ensure that the drive's P3 Mode is set to Disable.
3. Save the parameter settings using Parameter Save to ensure the present settings will be read.
4. Using a standard communications package, prepare the host computer to receive an ASCII file. Use a file extension like .MMI to differentiate it from .UDP format files.
5. Enable the host computer to begin receiving data.
6. Start the text download by selecting "DUMP MMI-> P3". The file transfer begins and will appear similar to the following:

```
DIGITAL DC DRIVE
ISSUE: 5.13
..DC 4Q 35A
....MENU LEVEL
.....DIAGNOSTICS
.....SPEED DEMAND [89 ] = 0.00 %
.....SPEED FEEDBACK [207 ] = 0.01 %
.....SPEED ERROR [297 ] = -0.01 %
.....SPEED LOOP O/P [549 ] = 0.00 %
.....CURRENT DEMAND [299 ] = 0.00 %
.....CURRENT FEEDBACK [298 ] = 0.00 %
etc.
```

Note: Enabling the transmitting port in a serial communications setup initiates data transfer. Therefore, enable the receiving port the host computer before beginning communication at the drive's P3 port.

7. The file ends with the CTRL-Z character. This character automatically closes the file in some serial communications software packages. If not, close the file manually when it has finished transferring data and when the host computer has stopped scrolling text.
8. Save the file to disk.

UDP (UPLOAD-DOWNLOAD PROTOCOL) SUPPORT

Use the P3 port to transfer ASCII files containing the drive's configuration and parameter settings between the 590 Digital drive and a host computer. The transfer uses a simple ASCII file structure and XON / XOFF protocol. Most communications packages use this protocol. A PC Pentium running Windows™ is required. Transferring data from the control to a host computer is defined as downloading; transferring data from a host computer to the control is an upload.

System Port P3 Continued

UDP Download (UDP XFER From P3)

A UDP download transfers the actual parameter and configuration settings from the control to a host computer. This file fully transfers all settings stored in EEPROM in a binary format and can be used as a back up file if the current drive settings are lost or if the drive is replaced.

Note: A UDP download transfers settings stored in EEPROM since the last Parameter Save was performed. Any parameter or configuration changes not saved to the EEPROM are not recorded within the UDP file.

1. Connect one end of the P3 cable to the P3 port and the other end to the PC's COM port.
2. Ensure that the drive's P3 Mode is set to Disable.
3. Save the parameter settings using Parameter Save to ensure that the drive's EEPROM parameters matches the drive's current parameter settings.
4. Using a standard communications package, prepare the host computer to receive an ASCII file. Use a file extension like .MMI to differentiate it from .UDP format files.
5. Enable the host computer to begin receiving data.
6. Start the UDP download from the control by selecting "UDP XFER-> P3".

Note: Enabling the transmitting port in a serial communications setup initiates data transfer. Therefore, enable the receiving port the host computer before beginning communication at the drive's P3 port.

7. The file ends with the CTRL-Z character. This character automatically closes the file in some serial communications software packages. If not, close the file manually when the PC has stopped scrolling text. The last line of the file should read :00000001FF.

UDP Upload (UDP XFER To P3)

A UDP Upload transfers a parameter file from the PC to the control memory. This information is written directly to EEPROM, so all the drive's current settings will be overwritten.

1. Connect one end of the P3 cable to the P3 port and the other end to the PC's COM port.
2. Ensure that the drive's P3 Mode is set to disable.
3. Using a standard communications package, prepare the host computer to send an ASCII file. Set the host computer's communications port parameters to the settings listed above. Be sure the baud rate and other COM settings at both ends of the serial communications match.
4. Start the upload by selecting "UDP XFER <- P3".
5. When the keypad displays "RECEIVING", begin the file transmission at the host computer.
6. The file ends in a :00000001FF which tells the control to close the file.
7. Reset the control by pressing the "E" key.

5703 Support The 5703 peer-to-peer communication option is not available.

- | | |
|------------------|-------------------------------|
| 1 SERIAL LINKS | 1 SYSTEM |
| 2 SYSTEM PORT P3 | 2 CONFIGURE I/O |
| 3 P3 SETUP | 3 CONFIGURE 5703 |
| 4 5703 SUPPORT | Source Tag
Destination Tag |

SETPT Ratio
SETPT Sign
Raw Input
Scaled Input

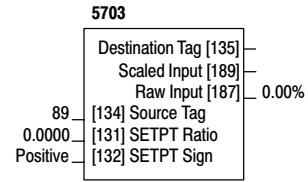

Parameter Descriptions

Scaled Input

Scaled input.

Range: xxx.xx %

Raw Input

Raw input.

Range: xxx.xx %

Source Tag

The source tag of the value to be sent to the 5703.

Range: 0 to 549

SETPT. Ratio

Input scaler.

Range: -3.0000 to 3.0000

SETPT. Sign

Input sign.

Range: 0 : Negative
1 : Positive

Destination Tag

(Keypad only) The destination tag of the value received from the 5703.

Range: 0 to 549

TEC Option

The Technology Option function block sets the inputs and outputs of the communications board options if installed. If a communications board is installed, refer to its manual for additional information.

1 SERIAL LINKS

2 TEC OPTION

TEC Option Type
TEC Option IN1
TEC Option IN2
TEC Option IN3
TEC Option IN4
TEC Option IN5
TEC Option Fault
TEC Option VER
TEC Option OUT1
TEC Option OUT2

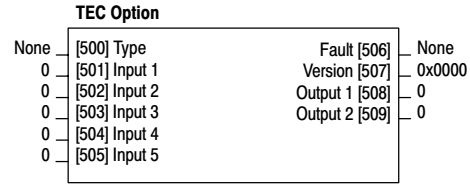

Parameter Descriptions

FAULT (TEC Option Fault)

The fault state of the Technology Option

- 0 : None – no faults
- 1 : Parameter – parameter out-of-range
- 2 : Type Mismatch – TYPE parameter mismatch
- 3 : Self Test – hardware fault – internal
- 4 : Hardware – hardware fault – external
- 5 : Missing – no option fitted
- 6 : Version Number – older than Version 2.x (TEC option is using software that doesn't fully support the drive.

Range: 0 to 6

VERSION (TEC Option)

The software version of the TEC Option. No option installed = zero.

Range: 0x0000 to 0xFFFF

OUTPUT 1 and 2 (TEC Option Out 1 to TEC Option Out 2)

The use of these output parameters depends upon the type of Technology Option installed. Refer to its manual for additional information.

Range: xxxxx

TYPE (TEC Option Type)

sets the type of Technology Option.

- 0 : None
- 1 : RS485
- 2 : Profibus DP
- 3 : Link
- 4 : Device Net
- 5 : Can Open
- 6 : Lonworks
- 7 : Type 7

Range: 0 to 7

Input 1 To Input 5 (TEC Option In 1 to TEC Option In 5)

The use of these input parameters depends upon the type of Technology Option installed. Refer to its manual for additional information.

Range: -32768 to 32767

Section 7

Keypad Operation

Keypad

The keypad allows full use of the Control's features. The keypad provides "Local" motor control, status monitoring, and complete access for application programming. The display, LEDs and keys are shown in Figure 7-1. The Keypad Display displays the status information during local or remote operation.

Figure 7-1 Keypad

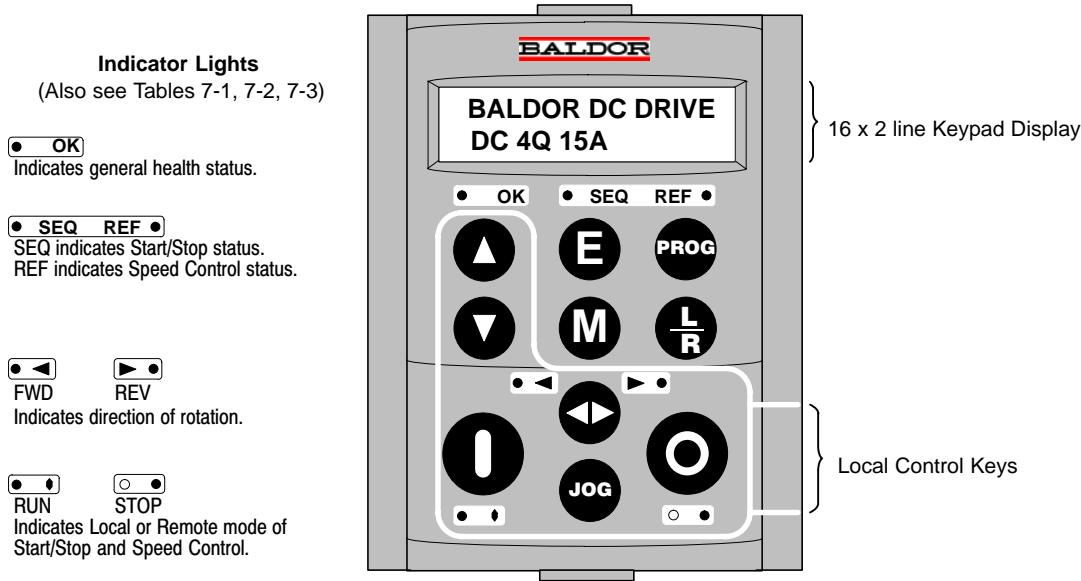

Indicator Lights

(Also see Tables 7-1, 7-2, 7-3)

● OK

Indicates general health status.

● SEQ REF ●

SEQ indicates Start/Stop status.
REF indicates Speed Control status.

◀ ▶

FWD REV
Indicates direction of rotation.

○ ●

RUN STOP
Indicates Local or Remote mode of Start/Stop and Speed Control.

Programming Keys



Navigation - Moves upward through the list of parameters.
Parameter - Increments the value of the displayed parameter.
Command Acknowledge - Confirms action in a command menu.
Local Mode - Increases motor speed.



Navigation - Moves downward through the list of parameters.
Parameter - Decrements the value of the displayed parameter.
Local Mode - Decreases motor speed.



Navigation - Displays the previous level's Menu.
Parameter - Returns to the parameter list.
Trip Acknowledge - Acknowledges Trip or Error message.



Navigation - Displays the next Menu level, or the first parameter of the current Menu.
Parameter - Press "M" when a parameter is displayed to see the parameter's Tag No. Repeated pressing at a writable parameter to control cursor movement.



Navigation - When in Local mode, displays the previous menu while remaining in Local mode enabling changes to be made to parameters not available in Local menu. Only operates in the Local mode.



Control - Changes between Local and Remote modes for both Start/Stop (Seq) and Speed Control (Ref). The keypad display will display the correct "Setpoint" screen and if in the Local mode, the "▲" and "▼" keys are used to change the setpoint.

Local Control Keys



Control - In Local mode this key runs the motor at the Local Setpoint speed.
Trip Reset - Resets a trip then runs the motor at the Local Setpoint speed. Only operates in the Local mode.



Control - In Local mode this key changes the direction of motor rotation. In Jog mode, it selects between two jog speeds. Only operates in the Local mode.



Control - In Local mode this key runs the motor at the Jog Speed 1 parameter value. When the key is released, the control stops the motor. This key only operates when the control is stopped and in the Local mode. Only operates in the Local mode.



Control - In Local mode this key stops the motor if motor is operating.
Trip Reset - If the control is tripped and the trip is no longer active, this key resets the trip conditions and clears the displayed message. Only operates in the Local mode.

Keypad LED Status

Seven LEDs indicate the status of the Control. Each LED (Figure 7-1) can operate in three different ways:
 Off , Blink , and On .

Table 7-1 Control Status

OK	Run	Stop	Control Status
<input type="checkbox"/> <input checked="" type="checkbox"/>	<input type="checkbox"/> <input checked="" type="checkbox"/>	<input type="checkbox"/> <input checked="" type="checkbox"/>	Re-Configuration
<input type="checkbox"/> <input checked="" type="checkbox"/>	<input type="checkbox"/>	<input checked="" type="checkbox"/>	Tripped
<input checked="" type="checkbox"/>	<input type="checkbox"/>	<input checked="" type="checkbox"/>	Stopped
<input checked="" type="checkbox"/>	<input type="checkbox"/>	<input type="checkbox"/> <input checked="" type="checkbox"/>	Stopping
<input checked="" type="checkbox"/>	<input type="checkbox"/> <input checked="" type="checkbox"/>	<input type="checkbox"/>	Running with Zero Reference
<input checked="" type="checkbox"/>	<input checked="" type="checkbox"/>	<input type="checkbox"/>	Running
<input checked="" type="checkbox"/>	<input type="checkbox"/> <input checked="" type="checkbox"/>	<input type="checkbox"/> <input checked="" type="checkbox"/>	Autotuning

Table 7-2 Forward Reverse Status

FWD	REV	Forward/Reverse Status
<input checked="" type="checkbox"/>	<input type="checkbox"/>	Commanded direction and actual direction are Forward.
<input type="checkbox"/>	<input checked="" type="checkbox"/>	Commanded direction and actual direction are Reverse (Series 30 only).
<input type="checkbox"/> <input checked="" type="checkbox"/>	<input type="checkbox"/>	Commanded direction is Forward but actual direction is Reverse (Series 30 only).
<input type="checkbox"/>	<input type="checkbox"/> <input checked="" type="checkbox"/>	Commanded direction is Reverse but actual direction is Forward.

Table 7-3 Local and Remote Status

SEQ	REF	Local/Remote Status
<input type="checkbox"/>	<input type="checkbox"/>	Start/Stop (Seq) and Speed Control (Ref) are controlled from the terminals (Remote).
<input checked="" type="checkbox"/>	<input checked="" type="checkbox"/>	Start/Stop (Seq) and Speed Control (Ref) are controlled from the keypad (Local).

Alarm Messages Operational failures called “Faults” or “Trips” are displayed at the keypad when they occur. They are also stored in memory and can be accessed for viewing. When a fault occurs, the control will “Trip” which means the motor stops and the control is disabled until it is reset. Press the “E” key to acknowledge the trip condition without resetting the fault. After the fault condition has been cleared press the Reset button to reset the control to restore operation. Refer to the Troubleshooting Section of this manual for additional information.

Local Menu

$\frac{L}{R}$ key (Figure 7-2)

Pressing the L/R key from anywhere in the Menu System activates the Local menu. The Local menu provides setpoint information for local operation. Pressing and holding the M key in the Local menu will display additional Feedback information. A display of forward or reverse feedback or reference whichever was previously selected by the FWD/REV key. Pressing the "M" key changes between feedback and reference.

Figure 7-2 Local Menu

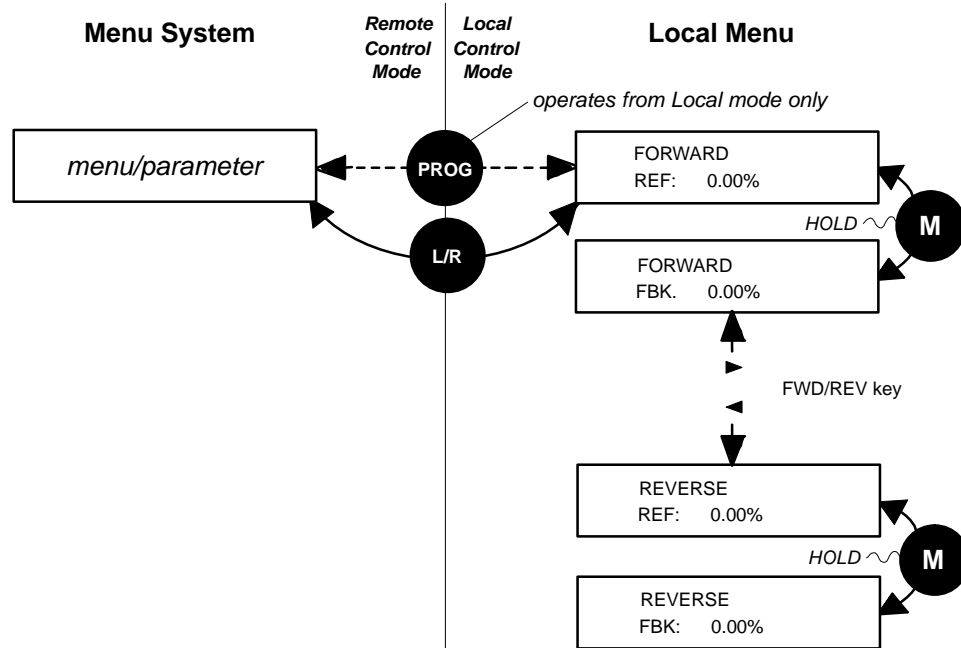

L/R Key

The L/R key (Local/Remote) only operates when the motor is stopped. It changes between Local and Remote modes. A Local menu is displayed in the Local mode, and a main programming menu is displayed in the Remote mode.

In Local, the Local LEDs, SEQ and REF, are illuminated and the RUN, STOP, JOG, ◀, ▶, ▲ and ▼ keys are used to control the motor direction and speed. Pressing the L/R key in Local mode selects Remote mode and returns to the previous menu.

PROG Key

The PROG key only operates in Local mode. It changes between the Local menu and the main Menu System but the control remains in Local mode. This allows you to change parameters normally available in Remote mode but remain in Local mode operation.

Menu System

The menu system is divided into nine major selections, shown in Table 7-4. Each selection has a structure of menus (Figure 7-3). At the keypad, press “M” to access the menus. Then press the ▲ or ▼ key to scroll through the menus.

Table 7-4 The Keypad Display of the Main Menu

Action	Description	Display	Comments
Apply Power		FORWARD REF: 0.00%	
Press “PROG” key		BALDOR DC DRIVE DC 4Q 15A	
Press “M” key 2 times	Access the menus.	DC 4Q 15A MENU LEVEL	
Press ▼	Scroll to next menu.	MENU LEVEL DIAGNOSTICS	Press “M” key to access Diagnostic menu.
Press ▼	Scroll to next menu.	MENU LEVEL SETUP PARAMETERS	Press “M” key to access Setup Parameters menu.
Press ▼	Scroll to next menu.	MENU LEVEL PASSWORD	Press “M” key to access Password menu.
Press ▼	Scroll to next menu.	MENU LEVEL ALARM STATUS	Press “M” key to access Alarm Status menu.
Press ▼	Scroll to next menu.	MENU LEVEL MENUS	Press “M” key to access Menus.
Press ▼	Scroll to next menu.	MENU LEVEL PARAMETER SAVE	
Press ▼	Scroll to next menu.	MENU LEVEL SERIAL LINKS	Press “M” key to access Serial Links menu.
Press ▼	Scroll to next menu.	MENU LEVEL SYSTEM	Press “M” key to access System menu.
Press ▼	Scroll to next menu.	MENU LEVEL CONFIGURE DRIVE	Press “M” key to access Configure Drive menu.

Menu Navigation

Remember, press “E” to return to the previous level of menus. Press “M” to enter the next level of menus. Press the ▲ or ▼ key to go to the previous or next menu item at the same level.

Figure 7-3 The Menu Map

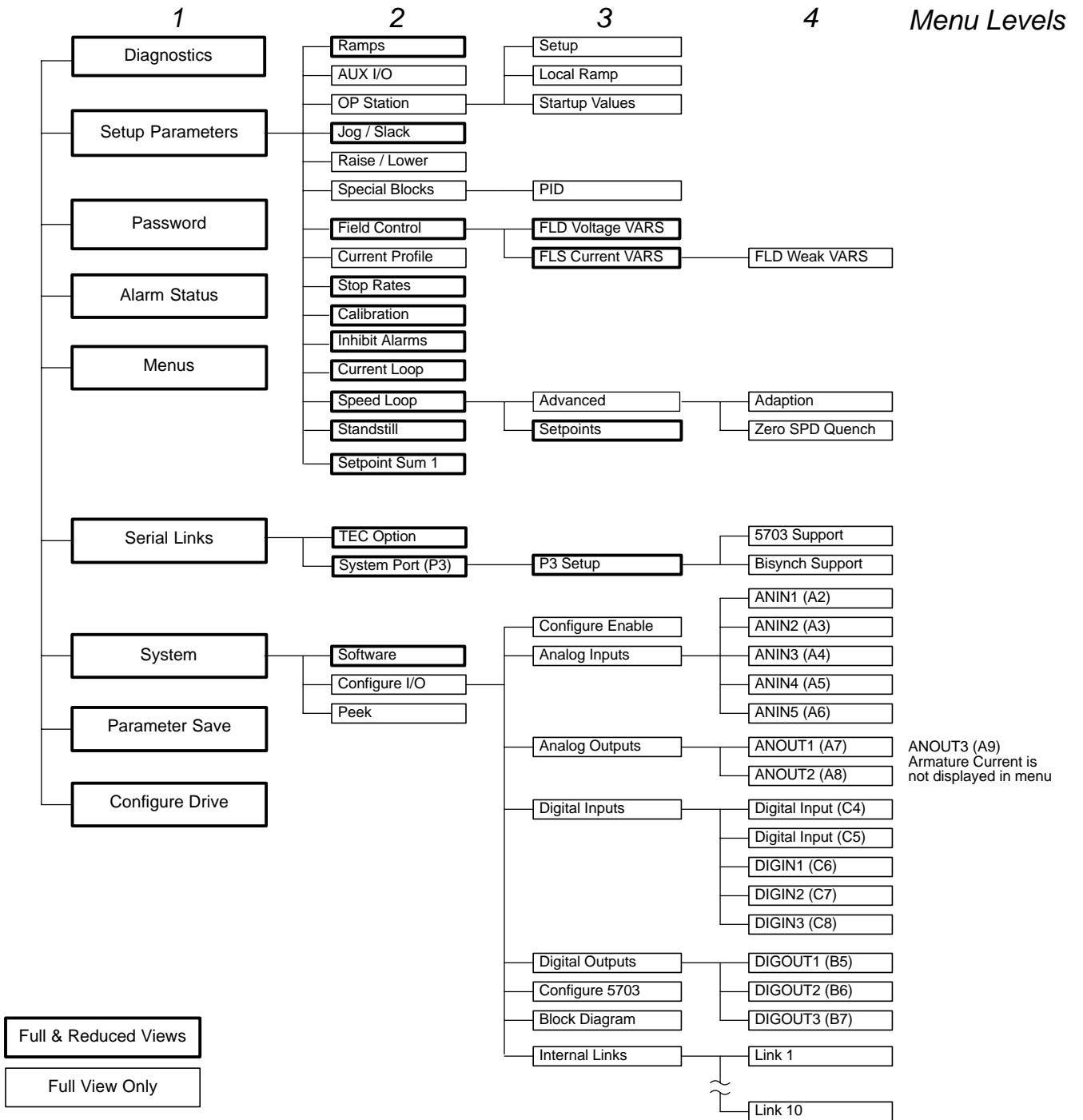

Menu Shortcuts and Special Key Combinations

Quick Tag Information

In any menu system, when a parameter is displayed hold down the “M” key for approximately $\frac{1}{2}$ second to display the tag number for that parameter. In section 3, the example was given as shown in Figure 7-4. Each parameter has a tag number associated with it. For example, the Output of Analog Input 1 has a tag number of [246]. The value of tag [246] is 100. Input 1 parameter of Setpoint Sum 1 has a tag number of [100].

Figure 7-4 Menu Map

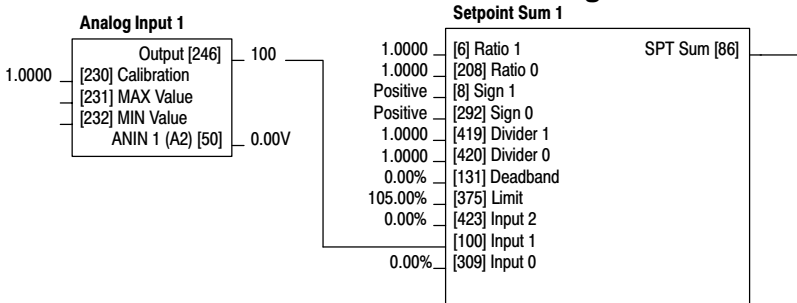

Restore Factory Settings (2 Button Reset)

Power-up the drive holding two keys as described in Figure 7-5. The drive is now safely configured with the factory settings described later in this manual (for the existing product code).

The factory settings are not automatically saved to non-volatile memory, so you must perform a Parameter Save to save the settings.

Figure 7-5 2 Button Reset

With power off, press and hold the UP and DOWN arrow keys. Apply power to the control and continue to hold both keys for at least 2 seconds.

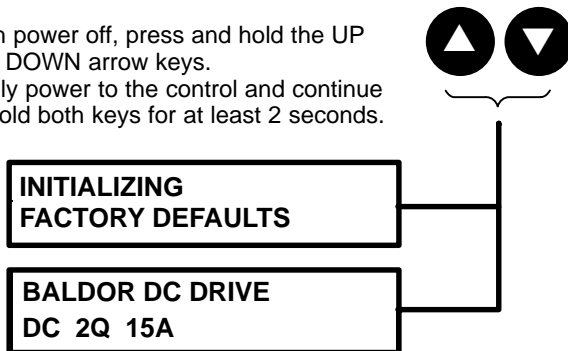

3 button reset (Changing the Power Base). This is only necessary if you are installing a new control board on an existing power base. Power-up the drive holding three keys as described in Figure 7-6. It is important that the control be configured for the correct power rating damage may occur to the drive when it attempts to run the motor. Continue to select the correct product code rating. Perform a parameter save now (refer to Save Settings).

Figure 7-6 3 Button Reset

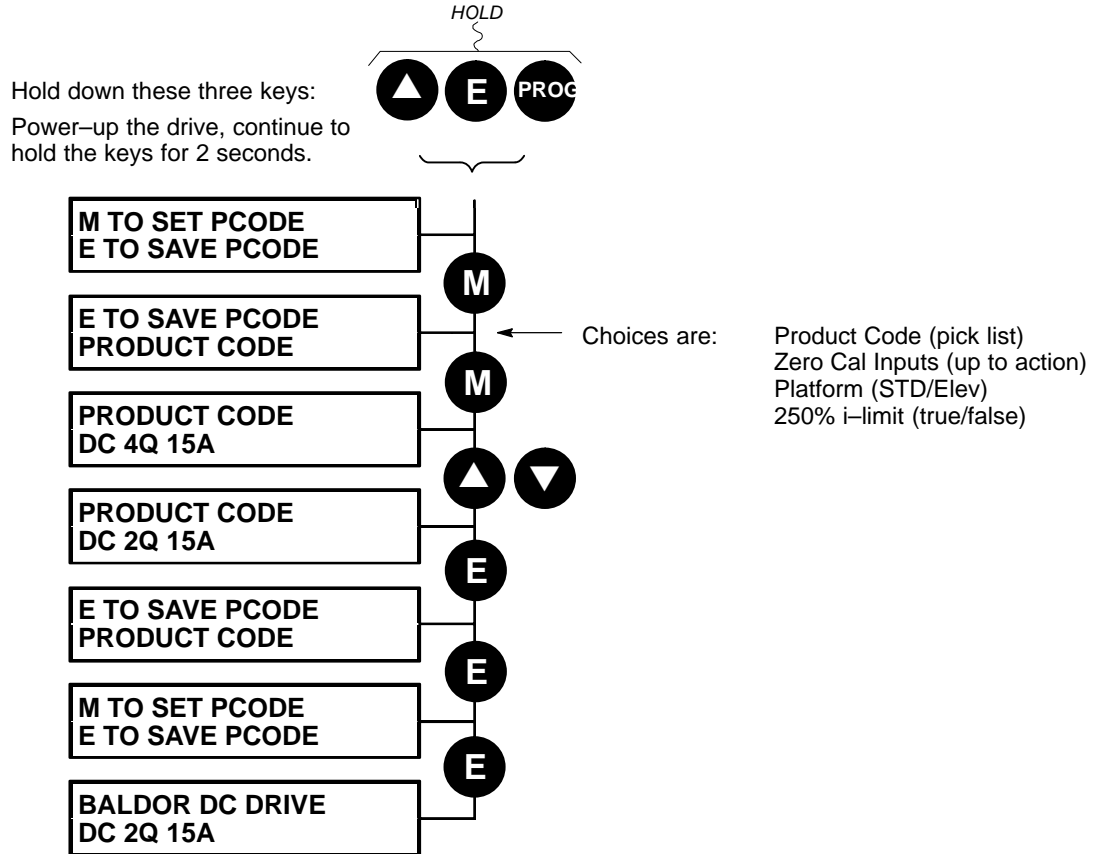

This is the preferred way of selecting a new product code. The available product codes are restricted to the set of codes that match the power base.

If the product code is changed during the 3-button reset, the following parameters are set to their factory value for the new product code:

- Tag [523] ARMATURE CURRENT
- Tag [524] FIELD CURRENT
- Tag [201] REGEN MODE



The 3-button reset does not cause the factory configuration to be loaded.

Operation Examples

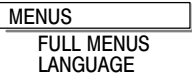
Select a Menu View Level Two view levels are available: Full view or Reduced view. These were illustrated in Figure 7-3.



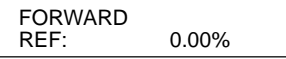

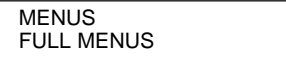
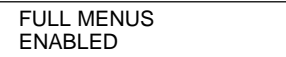
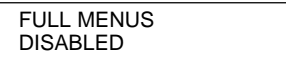
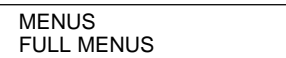

1 

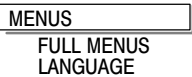
Full view shows all menu choices. Reduced view only shows a portion of the menu items.

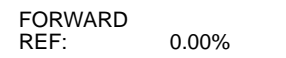
Action	Description	Display	Comments
Apply Power	Keypad Display shows this opening message.		This message is different for each control.
Press "PROG then press "M" 2 times	Access the menus.		
Press ▼	Scroll to "MENUS" menu.		
Press "M" key	Access the "MENUS" menus choices.		
Press "M" key	Access the "FULL MENUS" menus choices.		
Press ▼	Change to Reduced menus		
Press "E" key	Exit to the "MENUS" menus choices.		

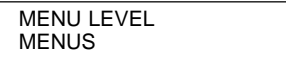
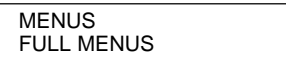
Language Selection English is the preset language that is saved in ROM. A second language option is available so that either can be selected. If a second language is selected, use the Parameter Save feature to store the new settings.

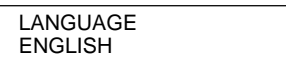
1 

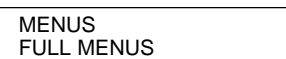
Action	Description	Display	Comments	
Apply Power	Keypad Display shows this opening message.		This message is different for each control.	
Press "PROG then press "M" 2 times	Access the menus.			
Press ▼	Scroll to "MENUS" menu.			
Press "M" key	Access the "MENUS" menus choices.			
Press ▼	Scroll to "Language" menu.			
Press "E" key	Exit to the "MENUS" menus choices.			Press "E" several times to return to the top level.
Press ▼	Scroll to the desired language.			
Press "E" key	Exit to the "MENUS" menus choices.		Press "E" several times to return to the top level.	

Password Protection

A password prevents unauthorized parameter modification by making all parameters “read-only”. If you attempt to modify a password protected parameter, it will cause “PASSWORD ??” to be displayed. The password protection is activated or deactivated using the ENTER PASSWORD and CHANGE PASSWORD parameters.

1 PASSWORD
 ENTER PASSWORD
 CHANGE PASSWORD

Activated: ENTER PASSWORD and CHANGE PASSWORD values are different.

Deactivated: ENTER PASSWORD and CHANGE PASSWORD values are same.

Action	Description	Display	Comments	
Apply Power	Keypad Display shows this opening message.	FORWARD REF: 0.00%	This message is different for each control.	
Press “PROG then press “M” 2 times	Access the menus.	MENU LEVEL DIAGNOSTICS		
Press ▼	Scroll to “PASSWORD” menu.	MENU LEVEL PASSWORD		
Press “M” key	Access the “ENTER PASSWORD” choice.	PASSWORD ENTER PASSWORD		
Press ▼	Scroll to the “CHANGE PASSWORD” choice.	PASSWORD CHANGE PASSWORD		
Press “M” key	Access the “CHANGE PASSWORD” choice.	CHANGE PASSWORD 0x0000		
Press ▲ or ▼ key	Select the new password.	CHANGE PASSWORD 0x0002		
Press “E” key	Exit one level	PASSWORD CHANGE PASSWORD		
Press ▼	Scroll to the “ENTER PASSWORD” choice.	PASSWORD ENTER PASSWORD		
Press “M” key	Access the “ENTER PASSWORD” choice.	ENTER PASSWORD 0X0002		The new password is automatically displayed.
Press ▲ or ▼ key	Select the new password.	ENTER PASSWORD 0x0000		Enter different password to activate.
Press “E” key	Exit one level	PASSWORD ENTER PASSWORD		Press “E” several times to return to the top level.

Deactivate a Password

When password protection is activated, you can no longer edit the CHANGE PASSWORD parameter until you deactivate the password protection (the value is displayed as “****”). First, enter the current password (e.g. 0x0002) in the ENTER PASSWORD parameter.

- 1
- ENTER PASSWORD
- CHANGE PASSWORD



Action	Description	Display	Comments	
Apply Power	Keypad Display shows this opening message.	<input type="text" value="FORWARD REF: 0.00%"/>	This message is different for each control.	
Press “PROG then press “M” 2 times	Access the menus.	<input type="text" value="MENU LEVEL DIAGNOSTICS"/>		
Press ▼	Scroll to “ENTER PASSWORD” menu.	<input type="text" value="MENU LEVEL ENTER PASSWORD"/>		
Press “M” key	Access the “ENTER PASSWORD” choice.	<input type="text" value="PASSWORD ENTER PASSWORD"/>		
Press “M” key	Access the “ENTER PASSWORD” choice.	<input type="text" value="ENTER PASSWORD 0X0000"/>		
Press ▲ or ▼ key	Select the new password.	<input type="text" value="ENTER PASSWORD 0x0002"/>		Enter password.
Press “E” key	Exit one level	<input type="text" value="PASSWORD ENTER PASSWORD"/>		Press “E” several times to return to the top level.

Now use the “Password Protection” procedure to set the Change Password value to “0X0000” to disable password protection if desired.

Note: Because the ENTER PASSWORD parameter value is always reset to 0x0000 when powering-up the drive, 0x0000 is the factory setting for the CHANGE PASSWORD parameter, i.e. by default, the two parameter values are the same and so password protection is disabled.





Save Settings

When parameter values have been changed they are not permanent until they are saved. If you turn power off then turn power on, the previous settings (stored in memory) will be used. To make your new parameter settings the power up settings, they must be saved to non-volatile memory. These new values are always used until this procedure is used to write new values to non-volatile memory.

- 1  SYSTEM
- 2  CONFIGURE I/O
CONFIGURE ENABLE

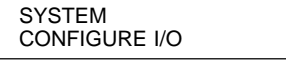
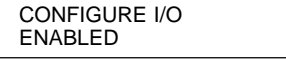
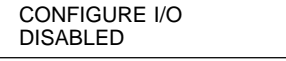
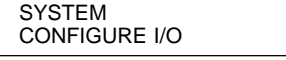
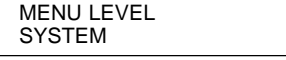
Note: Always ensure that "Configure I/O = Disabled" before doing a Parameter Save. If "Configure I/O = Enabled", the control cannot run the motor.

- 1  PARAMETER SAVE
PARAMETER SAVE

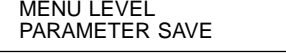
Action	Description	Display	Comments
Press ▼	Scroll to "SYSTEM" menu.		
Press "M" key			
Press "M" key			
Press ▲ or ▼ key	Select Disabled.		
Press "E" key	Exit one level		
Press "E" key	Exit one level		
Press ▼	Scroll to "PARAMETER SAVE" menu.		
Press "M" key			
Press ▲	Press ▲ to save parameters.		Parameters are saved. Except the "Local Setpoint".
Press "E" key	Exit one level		Press "E" several times to return to the top level.

Note: The Local Setpoint value is not saved as a parameter.

Section 8 Troubleshooting

Overview

When a trip occurs, the Control's power stage is immediately disabled (tripped) causing the motor and load to coast to a stop. The trip remains until action is taken to reset the fault, even if the original cause of the trip is no longer present. If a trip condition is detected the following occurs:

1. The "OK" LED goes off indicating a trip condition has occurred. (Investigate, find and remove the cause of the trip.)
2. Terminal B6 (Healthy) goes low (0V).

If a trip condition is detected, the keypad does the following actions.

1. The OK LED goes out indicating a Trip condition has occurred. The keypad displays the activated alarm. (Investigate, find and remove the cause of the trip.)
2. Terminal B6 (Healthy) goes low (0V).
3. The alarm message(s) can be acknowledged by pressing the **E** key, however, the unit will not restart at this point.

Reset a Trip Condition

All trips must be reset before the Control can be enabled. A trip can only be reset after the trip condition is no longer active. (For example, a trip due to a heatsink over-temperature can not be reset until the temperature is less than the trip level.)

More than one trip can be active at any time. For example, it is possible for both the Heatsink Trip and the Overvolts (VA) trips to be active. Alternatively it is possible for the control to trip due to a Field Over I error and then for the HEATSINK TRIP trip to become active after the control has stopped (this may occur due to the thermal time constant of the heatsink).

A trip is reset in one of two ways:

1. Power-up, or remove and re-apply the auxiliary power supply.
2. Stop and start the control, i.e. remove and re-apply the Start/Run signal (terminal C3 or C4, or the keypad Stop and Run keys).

Success is indicated when the "OK" LED is on. The keypad display will return to its original display.

Fault Conditions

Problem	Possible Cause	Remedy
Control will not power-up	Fuse blown	Check supply details, replace with correct fuse. Check Product Code against Model No.
	Faulty cabling	Check all connections are correct and secure. Check cable continuity
Control fuse keeps blowing	Faulty cabling or connections wrong	Check for problem and rectify before replacing with correct fuse
	Faulty control	Contact Baldor
Cannot obtain HEALTH state	Incorrect or no supply available	Check supply details
Motor will not run at switch on	Motor jammed	Stop the control and clear the jam
Motor runs and stops	Motor becomes jammed	Stop the control and clear the jam
Motor runs at full speed only	Reversed tachometer or open circuit tachometer	Check tachometer connections
	Open circuit speed reference potentiometer	Check terminal

Serial (P3) Errors This is an output parameter in the System Port (P3) function block, where the parameter value can be read and reset. The following values are returned if an inquiry (reading information from the control) is performed on this Read/Write parameter. Writing any value to this parameter will set the value to >00C0. Clearing the last error value may be useful to see if the error is re-occurring.

Value	Description
>00C0	No Error
>01C7	Invalid mnemonic
>02C2	Checksum (BCC) error
>03C2	Framing or overrun error
>04C8	Attempt to read from a write only parameter
>05C8	Attempt to write to a read only parameter
>07C7	Invalid message format
>07C8	Invalid data (encoding error)
>08C8	Data out of range

Alarm Messages When a trip occurs an alarm message is displayed at the keypad and information about the trip is stored in the Alarm Status menu. The alarm message and the Last Alarm parameter are displayed. The Health Store and Health Word parameters display information as hexadecimal values (0 – 9 and A, B, C, D, F shown in Table 8-1), or the sum of the hexadecimal values when more than one alarm is active. Therefore, the value can represent one or more alarms.

Table 8-1

Decimal number	Display
10	A
11	B
12	C
13	D
14	E
15	F

The Last Alarm, Health Word and Health Store parameters use a four digit hexadecimal value to identify individual trips. Each trip has a unique number.

Last Alarm (Tag [528]). This is the last alarm message to have been displayed. To reset the parameter simply press the ▼ (down) key to clear the alarm. Alternatively, you can switch the auxiliary supply off and on, causing No Active Alarms to be displayed.

Health Word (Tag [115]). This parameter continuously monitors the control status. As alarms are added or removed, the display immediately updates to show the hexadecimal sum of these alarms.

The value reverts to 0x0000 when the Start (C3) input is raised (+24V), and when no trip condition is present.

Health Store (Tag [116]). Stores the hexadecimal value of the first (or only) alarm to occur causing the trip condition. The display reverts to 0x0000 when the Start (C3) input is raised (+24V).

Table 8-2

LAST ALARM, HEALTH WORD and HEALTH STORE					
Trip		Trip Code			
		First Digit	Digit	Digit	Last Digit
	No active alarms				
0	Overspeed				1
1	Missing pulse				2
2	Field over I				4
3	Heatsink trip *				8
4	Thermistor			1	
5	Over volts (VA)			2	
6	SPD Feedback			4	
7	Encoder failed			8	
8	Field failed		1		
9	3 Phase failed *		2		
10	Phase lock		4		
11	5703 RCV Error		8		
12	Stall trip	1			
13	Over I trip	2			
14	Other ¹	4			
15	ACCTS Failed *	8			

¹ For the last alarm parameter, other is replaced with the trip codes in Table 8-3.

Table 8-3

Trip		LAST ALARM only			
14	Autotune error	F	0	0	1
14	Autotune aborted	F	0	0	2
14	External trip	F	0	0	5
14	Remote trip	F	0	0	6
14	CONFIG Enabled	F	2	0	0
14	No OP-Station	F	4	0	0
14	PCB Version	F	F	0	5
14	Product code	F	F	0	6

When more than one trip is to be represented at the same time then the trip codes are simply added together to form the value displayed. Within each digit, values between 10 and 15 are displayed as letters A to F shown in Table 8-1.

For example, if the Health Word parameter = **01A8**, this represents a “1” in digit 3, an “8” and a “2” in digit 2, (8+2 = 10, displayed as A) and an 8 in digit 1. This in turn represents the active trips Field Failed, Encoder Failed, Over Volts (VA) and Heatsink Trip (unlikely).

Power Board LED Trip Information (Frame 4 and 5)

The Heatsink Trip, 3 Phase Failed and ACCTS Failed trips are associated with the following LED indications:

Frame 4

Check the power board LEDs for more Heatsink Trip information. The LEDs are on to indicate a problem.

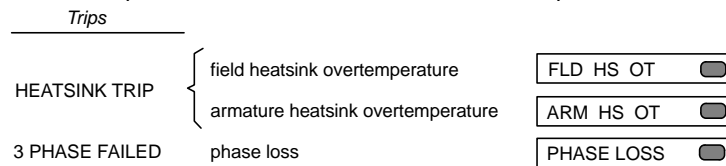

Frame 5

The master power board (on the left hand side of the unit) is fitted with a Parallel Expansion Board. This board has four additional LEDs providing information about the slave power board (on the right hand side of the unit), and about the general status of the unit.

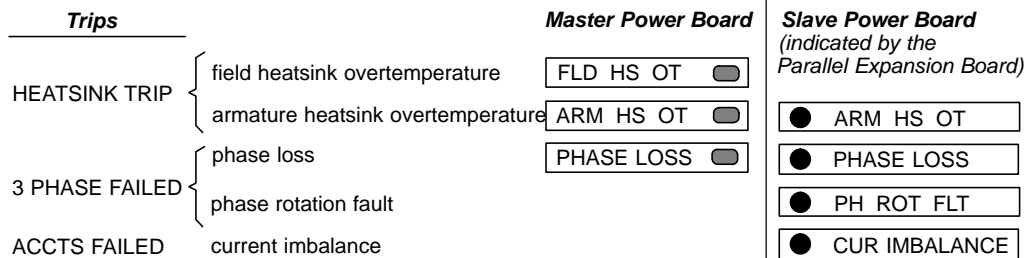

It is essential that the phase sequence applied to the two stacks are identical otherwise the converter will trip on 3 PHASE FAILED.

If there is a current imbalance between the stacks which exceeds 10% the converter will trip on ACCTS FAILED.

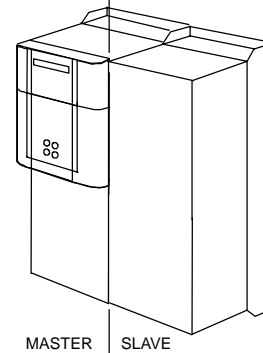

Manage Trips from the Keypad

Trip Messages Most of the alarms have a delay timer so that the control only trips if the condition persists for the whole of the delay period. If the control trips, the display immediately shows a message indicating the reason for the trip. These messages are shown in Table 8-4.

Table 8-4

Trip Message and Description	Possible Cause
Overspeed Motor overspeed – the speed feedback signal has exceeded 125% of rated speed.	Badly adjusted speed loop (alarm only operates with encoder or armature volts feedback selected) Alarm time delay : 0.1 seconds
Missing Pulse A missing pulse from the 6–pulse armature current waveform. Trips when the motor loading exceeds 1.5 times the Discontinuous parameter value.	Firing plug failure Connection failure Alarm time delay : 60 seconds
Field Over I The motor field current has exceeded 120% of the calibrated value	Regulator failure Badly tuned control loop (alarm only operates with field current control mode selected) Alarm time delay : 15 seconds
Heatsink Trip The control heatsink temperature is too high	The ambient air temperature is too high Poor ventilation or spacing between controls Fan failure, check fuse on power board, wrong rotation (models above 70A bridge rating) Blocked ventilation slots Clogged air filters Excessive armature current – nominal armature current on motor nameplate should be checked against the current calibration for the control. The stack must be allowed to cool in order to re–start the control. Alarm time delay : 0.75 seconds
Thermistor The motor temperature is too high	Inadequate ventilation Blower failure –check for direction, clogged air filters (models above 70A bridge rating) Excessive armature current – check nominal armature current on nameplate against current calibration) The motor must be allowed to cool in order to re–start the control. Alarm time delay : 15 seconds
Over Volts (VA) Motor armature voltage has exceeded 120% of rated volts	Loose armature connection Badly adjusted field voltage setting Badly adjusted field current loop Badly adjusted field–weakening bemf loop Badly adjusted speed loop Alarm time delay : 1.5 seconds
Speed Feedback The difference between speed feedback and armature voltage feedback is greater than the SPDFBK ALM Level parameter value If FLD Weak Enable parameter is enabled, speed feedback is less than 10% when in the field weakening region	Analog tachometer feedback polarity incorrect (terminals G3 and G4) The ENCODER SIGN parameter's polarity is incorrect Tachometer failure Tachometer coupling failure Alarm time delay : 0.4 seconds
Encoder Failed No speed feedback signal	The SPEED FBK SELECT parameter is set to ENCODER but an optional Encoder board is not installed. Check cable and connections on wire–ended encoder
Field Fail Field current is less than 6% of rated current when in Current Control mode Field current is less than 50mA when in Voltage Control mode (with default current burden of 15K)	Open circuit motor field – check connection and measure field resistance Faulty operation of field controller Where an AC supply feeds the onboard field regulator, check connections FL1 & FL2 for line–to–line voltage (rather than line–to–neutral) – L1 into FL1, L2 into FL2. The 3–phase supply must be present for synchronization. For loads where no field supply is required, e.g. a permanent magnet motor, set the FIELD ENABLE parameter to disable to suspend this alarm. Alarm time delay : 0.75 seconds

Table 8-4 Continued

Trip Message and Description	Possible Cause
3-Phase Failed 3-phase supply failure	Total failure of supply, or missing phase of 3-phase supply (detected under most circumstances) – check main AC supply to the control, check high-speed thyristor protection fuses, check power chassis coding fuses. Check the main AC voltage of the control (refer to Product Code). This alarm may not operate properly if the voltage is incorrect, i.e. wrong unit or control.
Phase Lock Supply frequency is outside the frequency band limits 45 – 65Hz	Check supply frequency Synchronization errors caused by distorted supply
5703 RCV Error Invalid data received via P3 port from another control	(Alarm only operates when MODE parameter is set to 5703 SLAVE)
STALL TRIP With motor stationary (AT ZERO SPEED parameter shows TRUE), current has exceeded the STALL THRESHOLD parameter value for longer than the STALL TRIP DELAY parameter value	(Alarm only operates when the STALL TRIP parameter is enabled).
OVER I TRIP Current feedback value has exceeded 280% of rated current	(300% loading not exceeding 15ms or 325% not exceeding 6.6ms is acceptable) Motor armature windings failure – check insulation resistance Badly tuned current loop Faulty control – Contact Baldor
ACCTS FAILED AC current transformer plug connection to control power board missing	Check armature current transformer plug for correct installation. Frame 5 only : Load imbalance between the two parallel power stacks The trip prevents the contactor closing and the current loop activating without armature current feedback – important in the case of external stack controllers where the thyristor stack is remote from the control board.
AUTOTUNE ERROR Speed feedback has exceeded 20% of rated speed, or field current feedback has exceeded 6% of rated field current	(Alarm only operates during the Autotune sequence).
AUTOTUNE ABORT The Autotune sequence has been aborted.	Coast Stop, Program Stop, Enable or Start Run terminal(s) disabled during Autotune sequence The AUTOTUNE parameter reset during the Autotune sequence Autotune sequence has timed-out (approximately 2 minutes).
REMOTE TRIP	REM. SEQUENCE parameter Remote Trip flag set to zero.
CONFIG INHIBIT	The drive was requested to start in Configuration mode.
CALIB INHIBIT	Calibration fault
COMMS FAULT CODE x	Operator Station faulty
OP STATION (Keypad)	Keypad has been disconnected from control while running in local mode.
0xF100 ERROR CAM FULL INIT 0xFF02 UNIMPLEMENTED OPCODE 0xFF03 ERROR NMI 0xFF04 ERROR TRAP 0xFF05 ERROR PCB VERSION 0xFF06 ERROR PRODUCT CODE 0xFF07 ERROR HSO FULL	These are internal software errors. If these should occur please contact Baldor.

Symbolic Alarm Messages These are generally internal software or hardware errors. If these occur please contact Baldor.

Number	Description	Action
0xF003	Pre-Ready Fault	Coding not present. Replace power board or chassis. (If an external stack, check coding supply field).
0xF004	Aux Contactor Open	The internal auxiliary 3-phase contactor failed to close.
0xF005	External Trip	Ext Trip (C2) open circuit.
0xF006	Remote Trip	REM. Sequence parameter Remote Trip flag set to zero.
0xFF03	Aux Power Fail	Check Aux. Supply and/or Main AC Input

Self Test Alarms

Self Test Alarm and Meaning	Possible Reason for Alarm
(EEPROM) CHECKSUM FAIL Parameters not saved, or are corrupted.	(The alarm appears at power-up or at the end of "Upload" UDP Transfer) Corrupted UDP file loaded – press the E key and perform a PARAMETER SAVE. The control will be returned to its factory default values.
ENABLE CONFIG. The ENABLE CONFIG. parameter has been left in the Enable state.	Select Disable for the ENABLE CONFIG. parameter
LANGUAGE CHECKSUM FAIL Incorrect language selected, or corrupted	(The alarm appears at power-up or at the end of "Upload" UDP Transfer) Corrupted UDP file loaded – press the E key and reload the correct language or de-select the second language.
INIT CAL FAIL Self calibration of analog inputs has exceeded normal tolerance	(The alarm appears at power-up) As a temporary measure, the tolerance can be increased by 0.1% with each press of the E key, however, this indicates a hardware fault – contact Baldor.
IA FBK CAL FAIL / IA INST CAL FAIL The self calibration of the armature current has failed	(The alarm appears at power-up) If powering the unit off and on does not remove the problem, a hardware failure is suspected. Contact Baldor.

Setting Trip Conditions The following parameters in the CALIBRATION menu are used to set trip conditions:

- Over Speed Level
- SPDFBK ALM Level
- Stall Threshold
- Stall Trip Delay
- Remote Trip Delay

Viewing Trip Conditions

The following parameters in the Level 1 ALARM STATUS menu can be viewed to investigate trip conditions:

- LAST ALARM
- HEALTH WORD
- HEALTH STORE
- THERMISTOR STATE
- SPEED FBK STATE
- STALL TRIP
- REMOTE TRIP

Inhibiting Alarms

The following alarms can be inhibited in the Setup Parameters::INHIBIT ALARMS menu.

- FIELD FAIL
- 5703 RCV ERROR
- STALL TRIP
- TRIP RESET
- SPEED FBK ALARM
- ENCODER ALARM
- REM TRIP INHIBIT

Note: The Stall Trip parameter in the Diagnostics menu is set regardless of the state of Stall Trip inhibit. The flag is set after the stall time-out expires. The relevant bit (bit 12) in the Health Word and Health Store parameters is only set when Stall Trip is enabled.

Test Points

The following test points are located on the control board and can be accessed through the Technology Option housing. When used with a meter, they will provide valuable information in the event of a fault. Contact Baldor for more information.

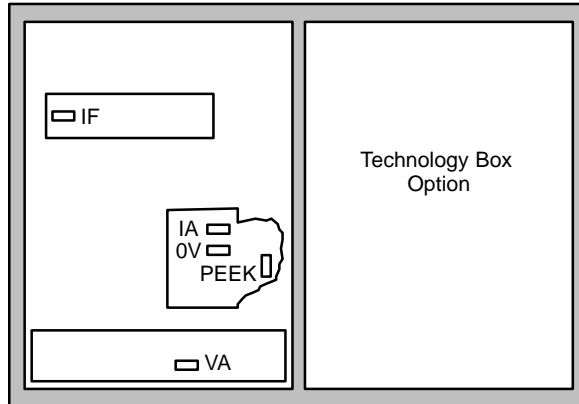

Table 8-5

Test Point	Description
IF	Field current feedback 0.0V = 0% 4.0V =100% (mean voltage), value of FIELD I FBK diagnostic, Tag No. 300
IA	Armature current feedback $\pm 1.1V \equiv \pm 100\%$ (mean current), value of CURRENT FEEDBACK diagnostic, Tag No. 298
VA	Armature volts feedback $\pm 10V \equiv \pm 100\%$ calculated VA (mean voltage), value of TERMINAL VOLTS diagnostic, Tag No. 57
OV	OV
PEEK	PEEK software (factory use only)

Maintenance

The Baldor control requires very little maintenance, if any, and should provide years of trouble free operation when installed and applied correctly. Occasional visual inspection and cleaning should be considered to ensure tight wiring connections and to remove dust, dirt, or foreign debris which can reduce heat dissipation. Before attempting to service this equipment, all input power must be removed from the control to avoid the possibility of electrical shock. The servicing of this equipment should be handled by a qualified electrical service technician experienced in the area of high power electronics. Electrical shock hazards are present inside this control.

Repair

Only qualified personnel should attempt to repair or replace parts. Isolate the control from all sources of electrical power before service is performed.

Save Your Data

The Control retains saved settings during power-down. You can download and upload these settings to a new or replacement control, if necessary. Data should be copied when the parameters were changed. You may attempt the back-up of your application data now, refer to "Copying an Application" in Section 7. If successful, the data can be restored to the new control. This information will be helpful when you contact Baldor for help.

Control Model number,

Voltage rating and

hp rating. These can be obtained from the motor nameplate.

Section 9 Specifications & Product Data

Identification

Digital DC Line
Regenerative Control

BC30D7A XXXX -CXX

Baldor Control
Series 30 Digital DC
230/460VAC, 3 Phase
Input Voltage

Logic Power (Single Phase)
CL7 Internal Logic Transformer
CL1 Requires 115VAC Logic Power
CL2 Requires 230VAC Logic Power

Output Amps

Specifications:

Enclosure:		Open Type (Chassis Mount)
Enclosure rating:	Europe North America / Canada	IP00 (Frame 1 is IP20) UL Open type
Enclosure Heat Rise: (if placed inside a totally enclosed cabinet)		The exposed metal surfaces dissipate approximately 50 Watts / m ² for a 10 °C temperature rise above the ambient
Horsepower:		5–300 HP, 3 Phase
Voltage Range:	230 VAC Models 460 VAC Models	198-242 VAC 3φ 60 Hz / 50 Hz 414-550 VAC 3φ 60 Hz / 50 Hz
Input Frequency:		50/60 HZ ± 5%
Logic Power:		Built in for size 1 and 2 controls. External for Size 3, 4 and 5 controls. 115VAC, 1 phase with 3A fast blow fuse.
AC Line Contactor:		Built in for size 1 and 2 controls. External for Size 3, 4 and 5 controls. 3 Amps maximum at control rated voltage.
Output Voltage:		DC; 0 – 1.2 times input VAC
Output Current:		See Ratings
Output Current Limit:		Adjustable 150% for 30 seconds, 200% for 10 seconds, 250% for 3 seconds
Service Factor:		1.0
Duty:		Continuous
Ambient Operating Temperature:		0 to +45 °C (sizes 1 & 2); 0 to +40 °C (sizes 3, 4 and 5) Derate Output 2% per °C over rating up to 55 °C Maximum
Rated Storage Temperature:		– 25 °C to +55 °C
Humidity:		10 to 85% RH at 40 °C Non-Condensing
Altitude:		Sea level to 1650 Feet (500 Meters) Derate 1% per 660 Feet (200 Meters) above 1650 Feet Maximum altitude 16,500 Feet (5,000 Meters)
Shock:		1G
Vibration:		0.5G at 10Hz to 60Hz
Climatic conditions:		Class 3k3, as defined by EN60721–3–3 (1995)
Safety:	Europe North America / Canada Overvoltage Category Pollution Degree	EN50178 (1998), when installed inside suitable enclosure. UL508C Category III (3 phase power), Category II (1 phase Logic power) Pollution Degree 2
EMC Compliance:	All models If external filters installed	European Directive 89 / 336 / EEC; EN50082–1 (1992) and EN50082–2 (1995) for immunity EN50081–2 (1994) Class A conducted emissions

Specifications: Continued**Keypad Display:**

Display:		Backlit LCD Alphanumeric 2 Lines x 16 Characters
Keys:		10 key membrane with tactile response
Display Function:	Running Setting Trip	Motor RPM, Output current, Voltage (selectable) Parameter values for setting and viewing Separate message for each trip, last trip retained in memory
LED Indicators:		OK FWD SEQ REV REF Run Stop
Remote Mount		10 feet (3m) max from control

Control Specifications:

Control Method:		Three phase, full wave, uni-directional DC control with 6 total pulses per cycle and 6 controlled pulses per cycle. NEMA Type C.		
Input Line Impedance:		5% Maximum		
Speed Feedback Type:		Armature (Standard) Encoder (optional, requires expansion board) Tachometer (optional, requires expansion board. 200V max without resistor) Pulse Generator		
Speed Setting:		±10VDC, 0–10VDC, 0–20mA, 4–20mA, RS232. Digital using keypad. Optional expansion board: RS485, ProfibusDP or DeviceNet.		
Accel / Decel Time:		0 - 600 seconds		
JOG Speed:		0 - Maximum speed		
Minimum Output Speed:		0 - 100% Maximum speed		
Maximum Output Speed:		0 - 200% Maximum speed		
Motor Matching:		Automatic tuning to motor with manual override		
Field Power Supply:	Type Voltage Current Field Economy Level	Full wave fixed voltage or current regulated DC; 0 to 90% of line input voltage 4 Amps (Size 1), 10 Amps (size 2 and 3), 30 Amps (size 4 and 5) Off or 50%		
Protective Functions:	Control Trip Fusing External Output	Monitored Alarm conditions (see Alarm Indications) Standard Input Line, Armature, Field and Control logic, High Energy MOV's. LED indicators for trip conditions, 3 assignable logic outputs– 30VDC, 3 ±10VDC analog outputs (2 assignable).		
Analog Inputs (5):	Full Scale Range Resolution Input impedance Update rate	±10VDC 12 bits + sign ≥ 10k ohms 10 milli seconds for 60Hz line (3milli seconds for Analog 2)		
Analog Outputs (3):	Full Scale Range Resolution Update rate	0–10VDC @ 5mA 10 bits + sign 10 milli seconds for 60Hz line		
Digital Inputs (5):	Rated Voltage Input impedance Update rate	10–30VDC ≥ 4.7k ohms 10 milli seconds for 60Hz line		
Digital Outputs (3):	Maximum Voltage On Current Sink On Voltage Drop	30VDC 100 mA maximum 2VDC maximum		
Alarm Indications:	Missing pulse SPD Feedback 5703 RCV Error Autotune Abort	Field over I Encoder failed Stall trip Remote Trip	Heatsink trip Field failed Over I trip Comms Fault Code	Thermistor 3 Phase failed ACCTS Failed

Specifications: Continued

Encoder

Maximum Pulse Rate	100kHz
Receiver Current	10mA per channel
Minimum Differential Input Voltage	3.5V
Encoder supply	5VDC, 12VDC, 15VDC or 24VDC; 2W maximum
Terminal Wire Size	16AWG

Tachometer

Maximum Input Voltage	200VDC
Switch settings	Selectable in 1VDC increments
Terminal Wire Size	16AWG

Terminal Tightening Torque

Terminals	Torque (by Control Size)					
	1	2		3	4	5
		40–110A	125–165A			
Power Connector (L1, L2, L3)	16 lb-in (1.8 Nm)	120 lb-in (13.5 Nm)		97 lb-in (11 Nm)	204 lb-in (23 Nm)	
Power Connector (A+, A-)	16 lb-in (1.8 Nm)	120 lb-in (13.5 Nm)	375 lb-in (42.4 Nm)	97 lb-in (11 Nm)	204 lb-in (23 Nm)	
Ground Terminals	17 lb-in (2.0 Nm)	120 lb-in (13.5Nm)		60 lb-in (6.8 Nm)		
Power Connector (F+, F-, BL1, BL2, BL3, FL1, FL2)	7 lb-in (0.8 Nm)				7 lb-in (0.8 Nm)	
Power Connector (L, N, 3, 4, TH1, TH2, Aux Cont–TB4)	5 lb-in (0.5 Nm)				5 lb-in (0.5 Nm)	
Power Connector (D1–D8, Term+, Therm-)				4 lb-in (0.45 Nm)		
Signal Connectors (A, B, C)	5 – 7 lb-in (0.6 – 0.8Nm)					
Encoder Expansion Board	3.5 in-lb (0.4Nm)					
Tachometer Expansion Board	5.3 in-lb (0.6Nm)					

Ratings

Catalog Number	Input VAC	Size	Max. Output				Logic Supply	AC Line Contactor	Approx. Ship Weight lbs.
			HP @230VAC	HP @460VAC	Armature Amps	Peak Amps			
BC29D7A35–CL7	230/460	1	10	20	35	53	Internal	Internal	14
BC29D7A70–CL7	230/460	2	20	40	70	105	Internal	Internal	23
BC29D7A110–CL7	230/460	2	30	60	110	165	Internal	Internal	23
BC29D7A165–CL7	230/460	2	50	100	165	248	Internal	Internal	23
BC29D7A243–CL1/CL2	230/460	3	75	150	243	365	External*	External	44
BC29D7A380–CL1/CL2	230/460	4	100	200	380	570	External*	External	71
BC29D7A500–CL1/CL2	230/460	4	150	300	500	750	External*	External	71
BC29D7A725–CL1/CL2	230/460	4	200	400	725	1088	External*	External	71
BC29D7A830–CL1/CL2	230/460	4	250	500	830	1245	External*	External	97
BC29D7A1580–CL1/CL2	230/460	5	450	900	1580	2370	External*	External	200

* CL1 requires 115VAC external logic supply.
 CL2 requires 230VAC external logic supply.

Dimensions

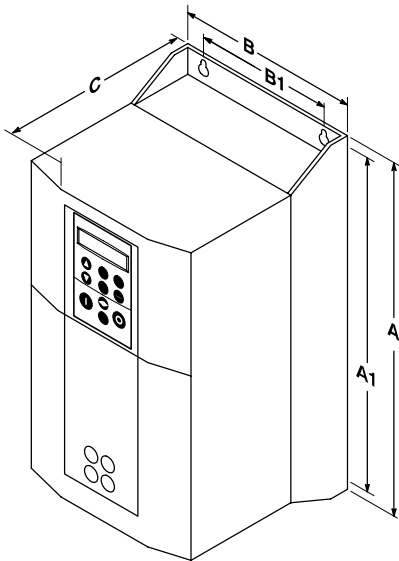

Size 1, 2, 3, 4

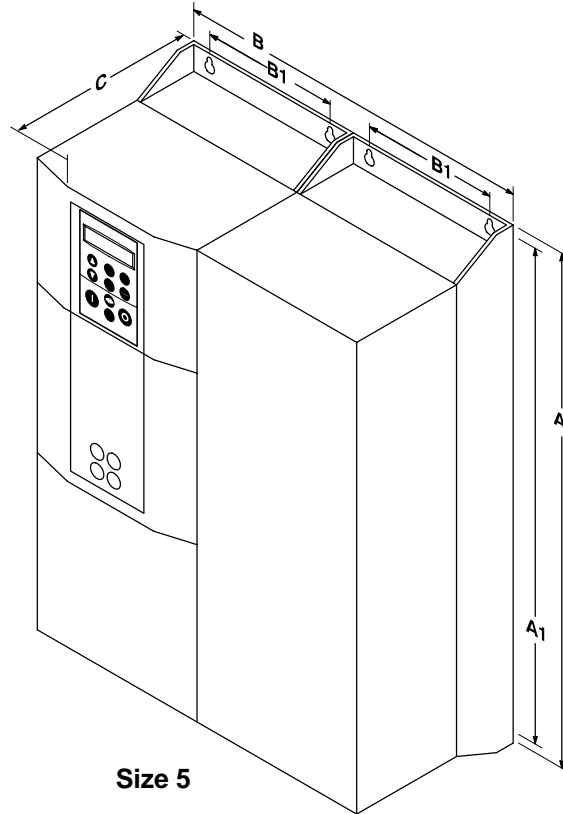

Size 5

For safe operation, allow a clearance distance between each control and on all sides of each control.

Size	Amp Rating	Dimensions				
		A	A1	B	B1	C
1	15–35	14.8 (375)	14.2 (360)	7.9 (200)	5.5 (140)	8.7 (220)
2	40–165	21.5 (546)	21.0 (530)	7.9 (200)	5.5 (140)	11.5 (292)
3	270	19.7 (500)	15.7 (400)	11.8 (297)	7.9 (200)	8.3 (213)
4 *	380–500	27.6 (700)	26.8 (680)	10.0 (253)	5.9 (150)	14.2 (358)
4 *	725–830	27.6 (700)	26.8 (680)	10.0 (253)	5.9 (150)	14.2 (358)
5 *	1580	27.6 (700)	26.8 (680)	20.0 (506)	5.9 (150)	14.2 (358)

* The height of Size 4 and 5 controls does not include the external vent kit. The height of the external vent is 10.39 (264) and approximately 3.9 (99) extends beyond the top of the enclosure.

Dimensions Continued

EMC Filters

EMC Filter Assemblies – 15A through 180A

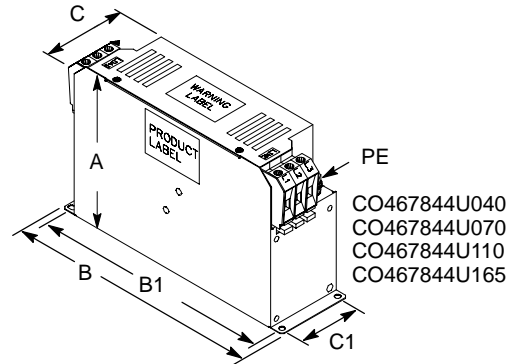
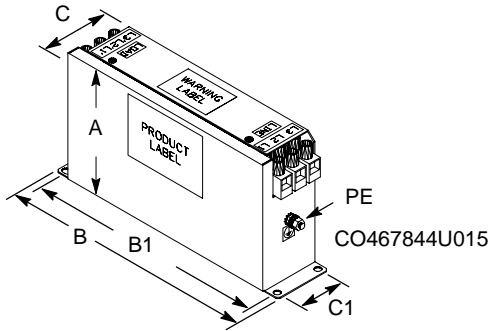

EMC Filter Assemblies – 270A and Larger

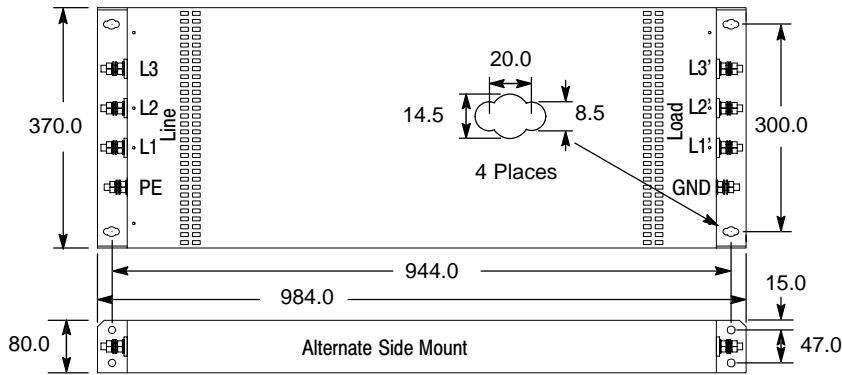

EMC Filter	A	B	B1	C	C1	PE
CO467844U015	4.49(114)	9.01(229)	8.54(217)	2.16(55)	1.65(42)	M5
CO467844U040	7.48(190)	12.28(312)	11.73(298)	3.66(93)	3.11(79)	M8
CO467844U070	7.48(190)	12.28(312)	11.73(298)	3.66(93)	3.11(79)	M8
CO467844U110	7.48(190)	12.28(312)	11.73(298)	3.66(93)	3.11(79)	M8
CO467844U165	8.82(224)	12.28(312)	11.73(298)	4.96(126)	4.41(112)	M10
CO467844U180	3.15(80)	38.74(984)	37.16(944)	14.57(370)	11.81(300)	M8

Appendix A

CE Guidelines

CE Declaration of Conformity

Baldor indicates that the products are only components and not ready for immediate or instant use within the meaning of "Safety law of appliance", "EMC Law" or "Machine directive".

The final mode of operation is defined only after installation into the user's equipment. It is the responsibility of the user to verify compliance.

The product conforms with the following standards:

DIN VDE 0160 / 05.88	Electronic equipment for use in electrical power installations
DIN VDE 0100	Erection of power installations with nominal voltages up to 1000V
DIN IEC 326 Teil 1 / 10.90	Design and use of printed boards
DIN VDE 0110Teil 1-2 / 01.89	Dimensioning of clearance and creepage distances
DIN VDE 0110Teil 20 / 08.90	distances
EN 60529 / 10.91	Degrees of protection provided by enclosures

EMC – Conformity and CE – Marking

The information contained herein is for your guidance only and does not guarantee that the installation will meet the requirements of the council directive 89/336/EEC.

The purpose of the EEC directives is to state a minimum technical requirement common to all the member states within the European Union. In turn, these minimum technical requirements are intended to enhance the levels of safety both directly and indirectly.

Council directive 89/336/EEC relating to Electro Magnetic Compliance (EMC) indicates that it is the responsibility of the system integrator to ensure that the entire system complies with all relative directives at the time of installing into service.

Motors and controls are used as components of a system, per the EMC directive. Hence all components, installation of the components, interconnection between components, and shielding and grounding of the system as a whole determines EMC compliance.

The CE mark does not inform the purchaser which directive the product complies with. It rests upon the manufacturer or his authorized representative to ensure the item in question complies fully with all the relative directives in force at the time of installing into service, in the same way as the system integrator previously mentioned. Remember, it is the instructions of installation and use, coupled with the product, that comply with the directive.

Wiring of Shielded (Screened) Cables

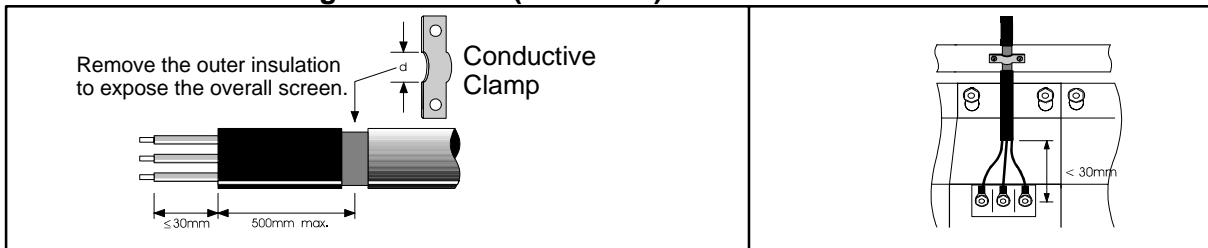

Using CE approved components will not guarantee a CE compliant system!

1. The components used in the drive, installation methods used, materials selected for interconnection of components are important.
2. The installation methods, interconnection materials, shielding, filtering and grounding of the system as a whole will determine CE compliance.
3. The responsibility of CE mark compliance rests entirely with the party who offers the end system for sale (such as an OEM or system integrator).

Baldor products which meet the EMC directive requirements are indicated with a "CE" mark. A duly signed CE declaration of conformity is available from Baldor.

EMC Wiring Technique

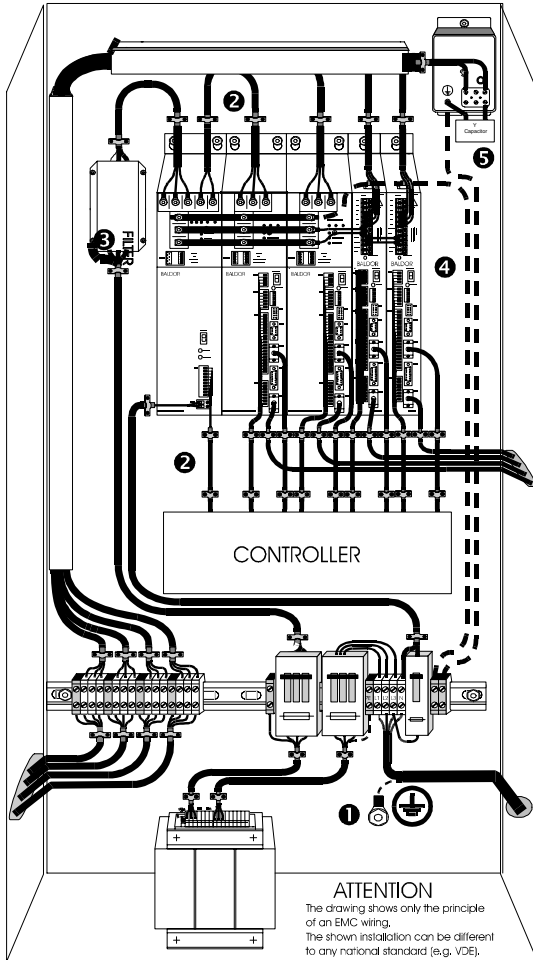

1 CABINET

The drawing shows an electroplated zinc coated enclosure, which is connected to ground.

This enclosure has the following advantages:

- All parts mounted on the back plane are connected to ground.
- All shield (screen) connections are connected to ground.

Within the cabinet there should be a spatial separation between power wiring (motor and AC power cables) and control wiring.

2 SCREEN CONNECTIONS

All connections between components must use shielded cables. The cable shields must be connected to the enclosure. Use conductive clamps to ensure good ground connection. With this technique, a good ground shield can be achieved.

3 EMC – FILTER

The EMI or main filter should be mounted next to the power supply (here BPS). For the connection to and from the main filter screened cables should be used. The cable screens should be connected to screen clamps on both sides. (Exception: Analog Command Signal).

4 Grounding (Earth)

For safety reasons (VDE0160), all BALDOR components must be connected to ground with a separate wire. The diameter of the wire must be at minimum AWG#6 (10mm²). Ground connections (dashed lines) must be made from the central ground to the regen resistor enclosure and from the central ground to the Shared Power Supply.

5 Y-CAPACITOR

The connection of the regeneration resistor can cause RFI (radio frequency interference) to be very high. To minimize RFI, a Y-capacitor is used. The capacitor should only be connected between the dynamic brake resistor housing and terminal pin R1 (lead from Lin).

Recommendation: 0,1µF / 250VAC Type: PME265
BALDOR-Ordering-No.: ASR27104

EMC Installation Instructions

To ensure electromagnetic compatibility (EMC), the following installation instructions should be completed. These steps help to reduce interference.

Consider the following:

- Grounding of all system elements to a central ground point
- Shielding of all cables and signal wires
- Filtering of power lines

A proper enclosure should have the following characteristics:

- All metal conducting parts of the enclosure must be electrically connected to the back plane. These connections should be made with a grounding strap from each element to a central grounding point. ¹
- Keep the power wiring (motor and power cable) and control wiring separated. If these wires must cross, be sure they cross at 90 degrees to minimize noise due to induction.
- The shield connections of the signal and power cables should be connected to the screen rails or clamps. The screen rails or clamps should be conductive clamps fastened to the cabinet. ²
- The cable to the regeneration resistor must be shielded. The shield must be connected to ground at both ends.
- The location of the AC mains filter has to be situated close to the drive so the AC power wires are as short as possible.
- Wires inside the enclosure should be placed as close as possible to conducting metal, cabinet walls and plates. It is advised to terminate unused wires to chassis ground. ¹
- To reduce ground current, use at least a 10mm² (6 AWG) solid wire for ground connections.

¹ Grounding in general describes all metal parts which can be connected to a protective conductor, e.g. housing of cabinet, motor housing, etc. to a central ground point. This central ground point is then connected to the main plant (or building) ground.

² Or run as twisted pair at minimum.

AC Line Filter, Choke and Motor Connections for CE

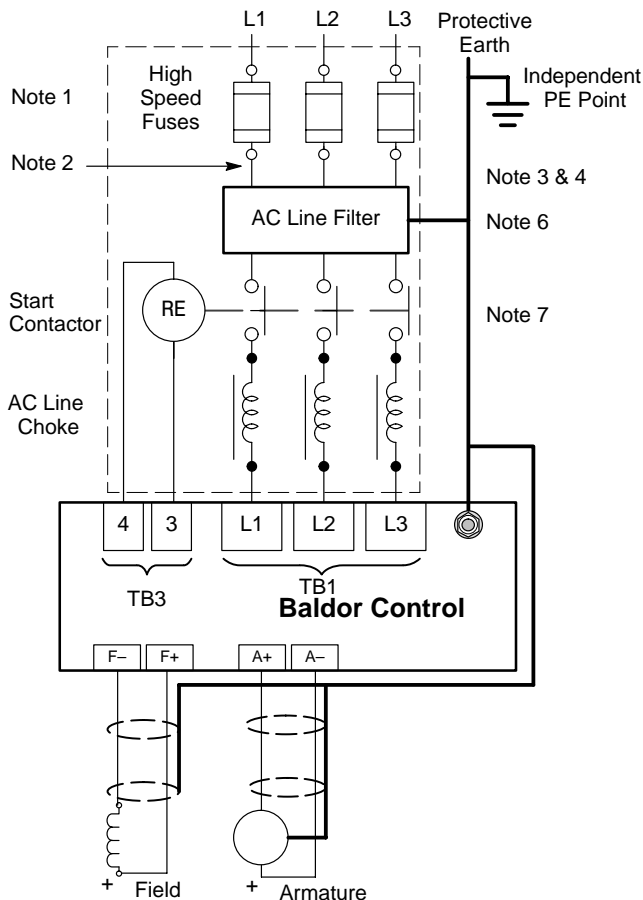

Notes:

- See Protection Device description in Section 4.
- Metal conduit or shielded cable should be used. Connect conduits so the use of a Reactor or RC Device does not interrupt EMI/RFI shielding.
- Use the same gauge wire for Earth as used for L1, L2, L3 connections.
- Use same gauge wire for Earth ground as is used for L and N, or L1, L2, L3. (VDE (Germany) requires 10mm² minimum, 6AWG).
- Reference EMC wiring in Appendix A for CE compliance.
- For EN60204 installations in Europe:
 - Each conductor used for earth connections must individually meet the protective earth (PE) conductor requirements.
 - AC Line Filter must be connected to earth.
 - For permanent earth connection, the control requires two protective earth conductors (10mm²) or one (10mm²) conductor connected to the independent PE point near the control.
 - The Motor PE conductor is run with the motor wires and in the same conduit. Connect to the independent PE point near the control.
 - Connect the control PE to the independent PE point near the control.
- AC Contactor is internal for size 1 and 2 controls. Size 3–5, the contactor can be connected between TB3–3 (line) and TB3–4 (neutral) and its purpose is to provide AC power disconnection. Maximum inrush current must not exceed 3A.

This figure shows optional components not furnished with control.

See Recommended Tightening Torques in Section 9.

Cable Screens Grounding

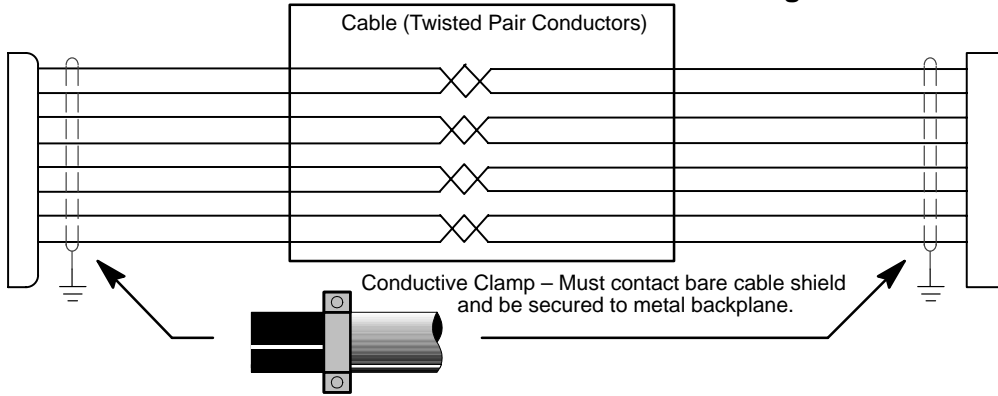

Input Signal Cable Grounding

Control

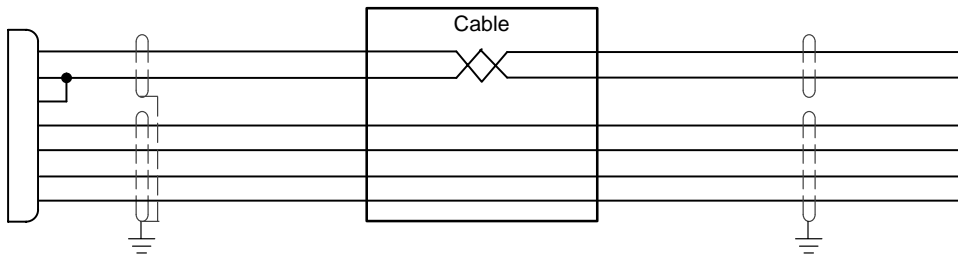

Simulated Encoder Output Cable Grounding

Control

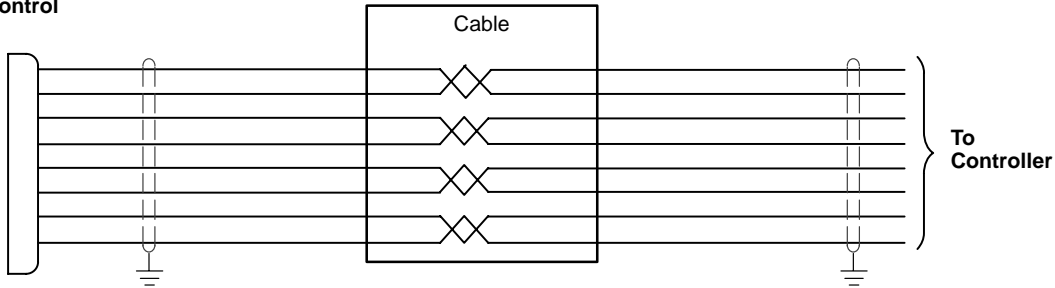

Encoder Cable Grounding

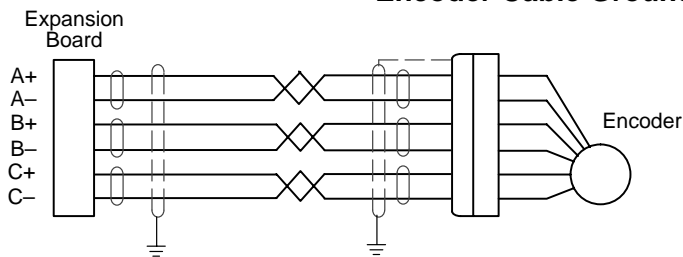

Appendix B Parameter Table

Parameter Values (Version 5.13) **RW:** RO = Read Only, RW = Read / Write. **WB Block** = WorkbenchD Block name.

Table B-1 Parameters Listed by Tag Number

Tag	R/W	Name	Keypad Menu	WB Block	Range	Factory Setting	MN	Notes
2	RW	Ramp Accel Time	SETUP PARAMETERS::RAMPS	Ramps	0.1 to 600.0 Secs	10.0 Secs	a2	
3	RW	Ramp Decel Time	SETUP PARAMETERS::RAMPS	Ramps	0.1 to 600.0 Secs	10.0 Secs	a3	
4	RW	Constant Accel	SETUP PARAMETERS::RAMPS	Ramps	0 : Disabled 1 : Enabled	Enabled	a4	
5	RW	Ramp Input	SETUP PARAMETERS::RAMPS	Ramps	-105.00 to 105.00 %	0.00%	a5	
6	RW	Ratio 1	SETUP PARAMETERS::SETPOINT SUM 1	Setpoint Sum 1	-3.0000 to 3.0000	1.0000	a6	
7	RW	Ratio 2 (A3)	SETUP PARAMETERS::SPEED LOOP::SET-POINTS	Speed Loop	-3.0000 to 3.0000	.0000	a7	
8	RW	Sign 1	SETUP PARAMETERS::SETPOINT SUM 1	Setpoint Sum 1	0 : Negative 1 : Positive	Positive	a8	
9	RW	Sign 2 (A3)	SETUP PARAMETERS::SPEED LOOP::SET-POINTS	Speed Loop	0 : Negative 1 : Positive	Positive	a9	
10	RW	Zero SPD. Offset	SETUP PARAMETERS::CALIBRATION	Calibration	-5.00 to 5.00 %	0.00%	aa	
11	RW	Standstill Logic	SETUP PARAMETERS::STANDSTILL	Standstill	0 : Disabled 1 : Enabled	Disabled	ab	
12	RW	Zero Threshold	SETUP PARAMETERS::STANDSTILL	Standstill	0.00 to 100.00 %	2.00%	ac	
13	RW	SPD.INT.TIME	CONFIGURE DRIVE	Speed Loop	0.001 to 30.000 Secs	0.500 Secs	ad	
14	RW	SPD.PROP.GAIN	CONFIGURE DRIVE	Speed Loop	0.00 to 200.00	10	ae	
15	RW	CUR.LIMIT/SCALER	CONFIGURE DRIVE	Current Loop	0.00 to 200.00 %	90.00%	af	
16	RW	PROP. GAIN	SETUP PARAMETERS::CURRENT LOOP	Current Loop	0.00 to 200.00	45.00	ag	
17	RW	INT. GAIN	SETUP PARAMETERS::CURRENT LOOP	Current Loop	0.00 to 200.00	3.50	ah	
18	RO	Autotune	CONFIGURE DRIVE	Current Loop	0 : Off 1 : On	Off	ai	Output, 1
19	RW	Field Fail	SETUP PARAMETERS::INHIBIT ALARMS	Alarms	0 : Enabled 1 : Inhibited	Enabled	aj	
20	RW	Armature V CAL.	SETUP PARAMETERS::CALIBRATION	Calibration	0.9800 to 1.1000	1.0000	ak	
21	RW	IR Compensation	SETUP PARAMETERS::CALIBRATION	Calibration	0.00 to 100.00 %	0.00%	al	
22	RW	Encoder RPM	CONFIGURE DRIVE	Calibration	0 to 6000 RPM	1750 RPM	am	
23	RW	Analog TACH CAL	SETUP PARAMETERS::CALIBRATION	Calibration	0.9800 to 1.1000	1.0000	an	
24	RW	Encoder Lines	CONFIGURE DRIVE	Calibration	10 to 5000	1024	ao	2
25	RW	Armature I (A9)	SETUP PARAMETERS::CALIBRATION	Calibration	0 : UNIPOLAR 1 : BIPOLAR	Bipolar	ap	
26	RW	PROG Stop Time	SETUP PARAMETERS::STOP RATES	Stop Rates	0.1 to 600.0 Secs	0.1 Secs	aq	
27	RW	Stop Time	SETUP PARAMETERS::STOP RATES	Stop Rates	0.1 to 600.0 Secs	10.0 Secs	ar	
28	RW	Stall Trip	SETUP PARAMETERS::INHIBIT ALARMS	Alarms	0 : Enabled 1 : Inhibited	Inhibited	as	
29	RW	Stop Zero Speed	SETUP PARAMETERS::STOP RATES	Stop Rates	0.00 to 100.00 %	2.00%	at	
30	RW	Additional DEM	SETUP PARAMETERS::CURRENT LOOP	Current Loop	-200.00 to 200.00 %	0.00%	au	
31	RW	SPD BRK2 (HIGH)	SETUP PARAMETERS::CURRENT PROFILE	Current Profile	0.00 to 100.00 % (h)	100.00%	av	2
32	RW	SPD BRK1 (LOW)	SETUP PARAMETERS::CURRENT PROFILE	Current Profile	0.00 to 100.00 % (h)	100.00%	aw	2
33	RW	IMAX BRK2 (SPD2)	SETUP PARAMETERS::CURRENT PROFILE	Current Profile	0.00 to 200.00 % (h)	200.00%	ax	2
37	RW	FULL MENUS	MENUS	Menus	0 : Disabled 1 : Enabled	Enabled	b1	
39	RW	Configure Enable	CONFIGURE DRIVE	Unallocated	0 : Disabled 1 : Enabled	Disabled	b3	2
41	RW	Setpoint 4	SETUP PARAMETERS::SPEED LOOP::SET-POINTS	Speed Loop	-105.00 to 105.00 %	0.00%	b5	
42	RO	At Current Limit	DIAGNOSTICS	Current Loop	0 : False 1 : True	False	b6	Output
43	RW	Modulus	SYSTEM::CONFIGURE I/O::DIGITAL OUTPUTS::DIGOUT 1 (B5)	Digout 1 (B5)	0 : False 1 : True	TRUE	b7	
44	RW	Modulus	SYSTEM::CONFIGURE I/O::DIGITAL OUTPUTS::DIGOUT 2 (B6)	Digout 2 (B6)	0 : False 1 : True	TRUE	b8	
45	RW	Modulus	SYSTEM::CONFIGURE I/O::DIGITAL OUTPUTS::DIGOUT 3 (B7)	Digout 3 (B7)	0 : False 1 : True	TRUE	b9	
47	RW	SPEED FBK SELECT	CONFIGURE DRIVE	Speed Loop	0 : Arm Volts Fbk 1 : Analog Tach 2 : Encoder 3 : Encoder/Analog	Arm Volts Fbk	bb 2	
48	RW	NEG. I CLAMP	SETUP PARAMETERS::CURRENT LOOP	Current Loop	-100.00 to 100.00 %	0.00%	bc	
49	RW	ENCODER SIGN	CONFIGURE DRIVE	Speed Loop	0 : Negative 1 : Positive	Positive	bd	2
50	RO	ANIN 1 (A2)	DIAGNOSTICS	Analog Input 1	xxx.xx VOLTS	0.00V	be	Output
51	RO	ANIN 2 (A3)	DIAGNOSTICS	Analog Input 2	xxx.xx VOLTS	0.00V	bf	Output
52	RO	ANIN 3 (A4)	DIAGNOSTICS	Analog Input 3	xxx.xx VOLTS	0.00V	bg	Output

- Notes:
1. This parameter is not saved in non-volatile memory.
 2. This parameter can only be written when control is stopped.
 3. This parameter can only be written when control is in configuration mode (stopped & Configure Drive::Configure Enable = Enabled).
 4. This parameter is reserved.

Table B-1 Parameters Listed by Tag Number Continued

Tag	R/W	Name	Keypad Menu	WB Block	Range	Factory Setting	MN	Notes
53	RO	ANIN 4 (A5)	DIAGNOSTICS	Analog Input 4	xxx.xx VOLTS	0.00V	bh	Output
54	RO	ANIN 5 (A6)	DIAGNOSTICS	Analog Input 5	xxx.xx VOLTS	10.00V	bi	Output
55	RO	ANOUT 1 (A7)	DIAGNOSTICS	Analog Output 1	xxx.xx VOLTS (h)	0.00V	bj	Output
56	RO	ANOUT 2 (A8)	DIAGNOSTICS	Analog Output 2	xxx.xx VOLTS (h)	0.00V	bk	Output
57	RO	Terminal Volts	DIAGNOSTICS	Calibration	xxx.xx % (h)	0.0%	bl	Output
58	RO	UNFIL.TACH INPUT	DIAGNOSTICS	Calibration	xxx.xx % (h)	0.0%	bm	Output
59	RO	UNFIL.ENCODER	DIAGNOSTICS	Calibration	xxxxx RPM	0 RPM	bn	Output
60	RO	BACK EMF	DIAGNOSTICS	Calibration	xxx.xx % (h)	0.0%	bo	Output
61	RO	ACTUAL NEG I LIM	DIAGNOSTICS	Diagnostics	xxx.xx % (h)	-90.0%	bp	Output
62	RO	UNFIL.SPD.FBK	DIAGNOSTICS	Speed Loop	xxx.xx %	0.03%	bq	Output
63	RO	Speed Setpoint	DIAGNOSTICS	Speed Loop	xxx.xx %	0.00%	br	Output
64	RO	UNFIL.SPD.ERROR	DIAGNOSTICS	Speed Loop	xxx.xx %	0.00%	bs	Output
65	RO	IaFbk UNFILTERED	DIAGNOSTICS	Current Loop	xxx.xx % (h)	0.0%	bt	Output
66	RO	IaDmd UNFILTERED	DIAGNOSTICS	Current Loop	xxx.xx % (h)	0.0%	bu	Output
67	RO	ACTUAL POS I LIM	DIAGNOSTICS	Diagnostics	xxx.xx % (h)	90.00%	bv	Output
68	RO	Start (C3)	DIAGNOSTICS	Aux I/O	0 : Off 1 : On	Off	bw	Output
69	RO	Digital Input C4	DIAGNOSTICS	Aux I/O	0 : Off 1 : On	Off	bx	Output
70	RO	Digital Input C5	DIAGNOSTICS	Aux I/O	0 : Off 1 : On	On	by	Output
71	RO	DIGIN 1 (C6)	DIAGNOSTICS	Digital Input 1	0 : Off 1 : On	Off	bz	Output
72	RO	DIGIN 2 (C7)	DIAGNOSTICS	Digital Input 2	0 : Off 1 : On	Off	c0	Output
73	RO	DIGIN 3 (C8)	DIAGNOSTICS	Digital Input 3	0 : Off 1 : On	Off	c1	Output
74	RO	DIGOUT 1 (B5)	DIAGNOSTICS	Digout 1 (B5)	0 : Off 1 : On	On	c2	Output
75	RO	DIGOUT 2 (B6)	DIAGNOSTICS	Digout 2 (B6)	0 : Off 1 : On	On	c3	Output
76	RO	DIGOUT 3 (B7)	DIAGNOSTICS	Digout 3 (B7)	0 : Off 1 : On	Off	c4	Output
77	RO	At Zero Speed	DIAGNOSTICS	Standstill	0 : False 1 : True	True	c5	Output
78	RO	At Zero Setpoint	DIAGNOSTICS	Standstill	0 : False 1 : True	True	c6	Output
79	RO	At Standstill	DIAGNOSTICS	Standstill	0 : False 1 : True	True	c7	Output
80	RO	Program Stop	DIAGNOSTICS	Stop Rates	0 : False 1 : True	False	c8	Output
81	RW	SPEED FBK ALARM	SETUP PARAMETERS::INHIBIT ALARMS	Alarms	0 : Enabled 1 : Inhibited	Enabled	c9	
82	RO	Drive Start	DIAGNOSTICS	Diagnostics	0 : Off 1 : On	Off	ca	Output
83	RO	Contactors Closed	DIAGNOSTICS	Unallocated	0 : Off 1 : On	Off	cb	Output
84	RO	Drive Enable	DIAGNOSTICS	Diagnostics	0 : Disabled 1 : Enabled	Disabled	cc	Output
85	RO	Ramp Output	DIAGNOSTICS	Ramps	xxx.xx %	0.00%	cd	Output
86	RO	SPT SUM OUTPUT	DIAGNOSTICS	Setpoint Sum 1	xxx.xx %	0.00%	ce	Output
87	RO	POS. I CLAMP	DIAGNOSTICS	Diagnostics	xxx.xx % (h)	90.0%	cf	Output
88	RO	NEG. I CLAMP	DIAGNOSTICS	Diagnostics	xxx.xx % (h)	-90.0%	cg	Output
89	RO	Speed Demand	DIAGNOSTICS	Stop Rates	xxx.xx %	0.00%	ch	Output
90	RW	Bipolar Clamps	SETUP PARAMETERS::CURRENT LOOP	Current Loop	0 : Disabled 1 : Enabled	Disabled	ci	
91	RW	PROG STOP I LIM	SETUP PARAMETERS::STOP RATES	Stop Rates	0.00 to 200.00 %	100.00%	cj	
92	RW	Encoder Alarm	SETUP PARAMETERS::INHIBIT ALARMS	Alarms	0 : Enabled 1 : Inhibited	Enabled	ck	
93	RW	IMAX BRK1(SPD1)	SETUP PARAMETERS::CURRENT PROFILE	Current Profile	0.00 to 200.00 % (h)	200.00%	cl	2
94	RW	AUX DIGOUT 1	SETUP PARAMETERS::AUX I/O	Aux I/O	0 : Off 1 : On	Off	cm	
95	RW	AUX DIGOUT 2	SETUP PARAMETERS::AUX I/O	Aux I/O	0 : Off 1 : On	Off	cn	
96	RW	AUX DIGOUT 3	SETUP PARAMETERS::AUX I/O	Aux I/O	0 : Off 1 : On	Off	co	
97	RW	Source Tag	SYSTEM::CONFIGURE I/O::DIGITAL OUTPUTS::DIGOUT 1 (B5)	Digout 1 (B5)	0 to 549	77	cp	2, 3
98	RW	Source Tag	SYSTEM::CONFIGURE I/O::DIGITAL OUTPUTS::DIGOUT 2 (B6)	Digout 2 (B6)	0 to 549	122	cq	2, 3
99	RW	Source Tag	SYSTEM::CONFIGURE I/O::DIGITAL OUTPUTS::DIGOUT 3 (B7)	Digout 3 (B7)	0 to 549	125	cr	2, 3
100	RW	Input 1	SETUP PARAMETERS::SETPOINT SUM 1	Setpoint Sum 1	-200.00 to 200.00 %	0.00%	cs	
102	RW	Destination Tag	SYSTEM::CONFIGURE I/O::DIGITAL INPUTS::DIGIN 1 (C6)	Digital Input 1	0 to 549	90	cu	2, 3
103	RW	Value For True	SYSTEM::CONFIGURE I/O::DIGITAL INPUTS::DIGIN 1 (C6)	Digital Input 1	-300.00 to 300.00 %	0.01%	cv	
104	RW	Value For False	SYSTEM::CONFIGURE I/O::DIGITAL INPUTS::DIGIN 1 (C6)	Digital Input 1	-300.00 to 300.00 %	0.00%	cw	
105	RW	Destination Tag	SYSTEM::CONFIGURE I/O::DIGITAL INPUTS::DIGIN 2 (C7)	Digital Input 2	0 to 549	118	cx	2, 3
106	RW	Value For True	SYSTEM::CONFIGURE I/O::DIGITAL INPUTS::DIGIN 2 (C7)	Digital Input 2	-300.00 to 300.00 %	0.01%	cy	

Table B-1 Parameters Listed by Tag Number Continued

Tag	R/W	Name	Keypad Menu	WB Block	Range	Factory Setting	MN	Notes
107	RW	Value For False	SYSTEM::CONFIGURE I/O::DIGITAL IN-PUTS::DIGIN 2 (C7)	Digital Input 2	-300.00 to 300.00 %	0.00%	cz	
108	RW	Destination Tag	SYSTEM::CONFIGURE I/O::DIGITAL IN-PUTS::DIGIN 3 (C8)	Digital Input 3	0 to 549	119	d0	2, 3
109	RW	Value For True	SYSTEM::CONFIGURE I/O::DIGITAL IN-PUTS::DIGIN 3 (C8)	Digital Input 3	-300.00 to 300.00 %	0.01%	d1	
110	RW	Value For False	SYSTEM::CONFIGURE I/O::DIGITAL IN-PUTS::DIGIN 3 (C8)	Digital Input 3	-300.00 to 300.00 %	0.00%	d2	
111	RW	5703 RCV ERROR	SETUP PARAMETERS::INHIBIT ALARMS	Alarms	0 : Enabled 1 : Inhibited	Enabled	d3	
112	RO	Stall Trip	ALARM STATUS	Alarms	0 : OK 1 : Failed	OK	d4	Output
113	RO	Ramping	DIAGNOSTICS	Ramps	0 : False 1 : True	False	d5	Output
115	RO	Health Word	ALARM STATUS	Alarms	0x0000 to 0xFFFF	0x0200	d7	Output
116	RO	Health Store	ALARM STATUS	Alarms	0x0000 to 0xFFFF	0x0000	d8	Output
118	RW	Ramp Hold	SETUP PARAMETERS::RAMPS	Ramps	0 : Off 1 : On	Off	da	
119	RW	I DMD. ISOLATE	SETUP PARAMETERS::CURRENT LOOP	Current Loop	0 : Disabled 1 : Enabled	Disabled	db	
120	RW	Enter Password	PASSWORD		0x0000 to 0xFFFF	0x0000	dc	1
121	RW	Change Password	PASSWORD		0x0000 to 0xFFFF	0x0000	dd	
122	RO	Health LED	DIAGNOSTICS	Alarms	0 : False 1 : True	True	de	Output
123	RW	Peek Data	SYSTEM::PEEK		0x0000 to 0xFFFF	0x0078	df	
124	RW	Peek Scale	SYSTEM::PEEK		-300.00 to 300.00	8.00	dg	
125	RO	Ready	DIAGNOSTICS	Alarms	0 : False 1 : True	False	dh	Output
126	RW	MIN SPEED	SETUP PARAMETERS::RAMPS	Ramps	0.00 to 100.00 %	0.00%	di	
128	RW	ANOUT 1	SETUP PARAMETERS::AUX I/O	Aux I/O	-100.00 to 100.00 %	0.00%	dk	
129	RW	ANOUT 2	SETUP PARAMETERS::AUX I/O	Aux I/O	-100.00 to 100.00 %	0.00%	dl	
130	RW	Mode	SERIAL LINKS::SYSTEM PORT (P3)::P3 SET-UP	System Port P3	0 : Disabled 1 : 5703 Master 2 : 5703 Slave 3 : CELite (EIASCII)	0	dm	
131	RW	Deadband Width	SETUP PARAMETERS::SETPOINT SUM 1	Setpoint Sum 1	0.00 to 100.00 % (h)	0.0%	dn	
132	RW	SETPT. RATIO	SERIAL LINKS::SYSTEM PORT (P3)::P3 SET-UP::5703 SUPPORT	5703	-3.0000 to 3.0000	0.0000	do	
133	RW	SETPT. SIGN	SERIAL LINKS::SYSTEM PORT (P3)::P3 SET-UP::5703 SUPPORT	5703	0 : Negative 1 : Positive	Positive	dp	
134	RW	Source Tag	SYSTEM::CONFIGURE I/O::CONFIGURE 5703	5703	0 to 549	89	dq	2, 3
135	RW	Destination Tag	SYSTEM::CONFIGURE I/O::CONFIGURE 5703	Scaled 5703 In-put	0 to 549	41	dr	2, 3
136	RW	Feed Forward	SETUP PARAMETERS::CURRENT LOOP	Current Loop	0.10 to 50.00	2.00	ds	4
137	RW	Discontinuous	SETUP PARAMETERS::CURRENT LOOP	Current Loop	0.00 to 200.00 %	12.00%	dt	
155	RO	Version Number	SERIAL LINKS::SYSTEM PORT (P3)	Unallocated	0x0000 to 0xFFFF		eb	Output
161	RW	AUX START	SETUP PARAMETERS::AUX I/O	Aux I/O	0 : Off 1 : On	On	eh	
168	RW	Aux Enable	SETUP PARAMETERS::AUX I/O	Aux I/O	0 : Off 1 : On	On	eo	
169	RO	Field Enabled	DIAGNOSTICS	Field Control	0 : Disabled 1 : Enabled	Disabled	ep	Output
170	RW	Field Enable	SETUP PARAMETERS::FIELD CONTROL	Field Control	0 : Disabled 1 : Enabled	Enabled	eq	2
171	RW	Setpoint	SETUP PARAMETERS::FIELD CON-TROL::FLD.CURRENT VARS	Field Control	0.00 to 100.00 %	100.00%	er	
172	RW	INT. GAIN	SETUP PARAMETERS::FIELD CON-TROL::FLD.CURRENT VARS	Field Control	0.00 to 100.00	1.28	es	
173	RW	PROP. GAIN	SETUP PARAMETERS::FIELD CON-TROL::FLD.CURRENT VARS	Field Control	0.00 to 100.00	0.10	et	
174	RW	FLD. WEAK ENABLE	SETUP PARAMETERS::FIELD CON-TROL::FLD.CURRENT VARS::FLD.WEAK VARS	Field Control	0 : Disabled 1 : Enabled	Disabled	eu	2
175	RW	EMF LEAD	SETUP PARAMETERS::FIELD CON-TROL::FLD.CURRENT VARS::FLD.WEAK VARS	Field Control	0.10 to 50.00	2.00	ev	
176	RW	EMF LAG	SETUP PARAMETERS::FIELD CON-TROL::FLD.CURRENT VARS::FLD.WEAK VARS	Field Control	0.00 to 200.00	40.00	ew	
177	RW	EMF GAIN	SETUP PARAMETERS::FIELD CON-TROL::FLD.CURRENT VARS::FLD.WEAK VARS	Field Control	0.00 to 100.00	0.30	ex	
178	RW	MAX VOLTS	SETUP PARAMETERS::FIELD CON-TROL::FLD.CURRENT VARS::FLD.WEAK VARS	Field Control	0.00 to 100.00 %	100.00%	ey	
179	RW	MIN FLD.CURRENT	SETUP PARAMETERS::FIELD CON-TROL::FLD.CURRENT VARS::FLD.WEAK VARS	Field Control	0.00 to 100.00 %	10.00%	ez	2
180	RW	SPDFBK ALM LEVEL	SETUP PARAMETERS::CALIBRATION	Calibration	0.00 to 100.00 % (h)	50.00%	fo	

Table B-1 Parameters Listed by Tag Number Continued

Tag	R/W	Name	Keypad Menu	WB Block	Range	Factory Setting	MN	Notes
181	RO	Unfil. Field FBK	DIAGNOSTICS	Calibration	xxx.xx %	0.00%	f1	Output
182	RW	Field I CAL.	SETUP PARAMETERS::CALIBRATION	Calibration	0.9800 to 1.1000	1.0000	f2	
183	RO	Field Demand	DIAGNOSTICS	Field Control	xxx.xx %	0.00%	f3	Output
184	RO	FLD.FIRING ANGLE	DIAGNOSTICS	Field Control	xxx.xx DEG	0.00 Deg	f4	Output
185	RW	FLD.QUENCH DELAY	SETUP PARAMETERS::FIELD CONTROL	Field Control	0.0 to 600.0 Secs	0.0 Secs	f5	
186	RW	FLD. QUENCH MODE	SETUP PARAMETERS::FIELD CONTROL	Field Control	0 : Quench 1 : Standby	Quench	f6	
187	RO	Raw Input	SERIAL LINKS::SYSTEM PORT (P3)::P3 SETUP::5703 SUPPORT	5703	xxx.xx %	0.00%	f7	Output
188	RW	Over Speed Level	SETUP PARAMETERS::CALIBRATION	Calibration	0.00 to 200.00 %	125.00%	f8	4
189	RO	Scaled Input	SERIAL LINKS::SYSTEM PORT (P3)::P3 SETUP::5703 SUPPORT	5703	xxx.xx %	0.00%	f9	Output, 2
191	RW	BEMF FBK LEAD	SETUP PARAMETERS::FIELD CONTROL::FLD.CURRENT VARS::FLD.WEAK VARS	Field Control	10 to 5000	100	fb	
192	RW	BEMF FBK LAG	SETUP PARAMETERS::FIELD CONTROL::FLD.CURRENT VARS::FLD.WEAK VARS	Field Control	10 to 5000	100	fc	
195	RW	Threshold (>)	SYSTEM::CONFIGURE I/O::DIGITAL OUTPUTS::DIGOUT 1 (B5)	Digout 1 (B5)	-300.00 to 300.00 %	0.00%	ff	2
196	RW	Threshold (>)	SYSTEM::CONFIGURE I/O::DIGITAL OUTPUTS::DIGOUT 2 (B6)	Digout 2 (B6)	-300.00 to 300.00 %	0.00%	fg	2
197	RW	Threshold (>)	SYSTEM::CONFIGURE I/O::DIGITAL OUTPUTS::DIGOUT 3 (B7)	Digout 3 (B7)	-300.00 to 300.00 %	0.00%	fh	2
198	RW	P3 Baud Rate	SERIAL LINKS::SYSTEM PORT (P3)::P3 SETUP		0:300 1:600 2:1200 3:2400 4:4800 5:9600 6:19200	9600	fi	2
199	RW	Delay	SETUP PARAMETERS::INVERSE TIME	Inverse Time	0.1 to 600.0 Secs	10.0 Secs	fj	2, 4
200	RW	Rate	SETUP PARAMETERS::INVERSE TIME	Inverse Time	0.1 to 600.0 Secs	60.0 Secs	fk	2, 4
201	RW	Regen Mode	SETUP PARAMETERS::CURRENT LOOP	Current Loop	0 : 2Q (Non-regen) 1 : 4Q (Regen)	2Q(Non-regen)	fl	2
202	RW	INT. DEFEAT	SETUP PARAMETERS::SPEED LOOP	Speed Loop	0 : Off 1 : On	Off	fm	
203	RO	Inverse Time O/P	DIAGNOSTICS	Inverse Time	xxx.xx %	200.0%	fn	Output, 2, 4
204	RW	Aiming Point	SETUP PARAMETERS::INVERSE TIME	Inverse Time	0.00 to 103.00 %	103.00%	fo	2, 4
206	RO	Encoder	DIAGNOSTICS	Diagnostics	xxxxx RPM	0 RPM	fq	Output
207	RO	Speed Feedback	DIAGNOSTICS	Diagnostics	xxx.xx %	0.01%	fr	Output
208	RW	Ratio 0	SETUP PARAMETERS::SETPOINT SUM 1	Setpoint Sum 1	-3.0000 to 3.0000	1.0000	fs	
209	RW	FLD.CTRL MODE	CONFIGURE DRIVE	Field Control	0 : Voltage Control 1 : Current Control	Voltage Control	ft	2
210	RW	FLD.VOLTS RATIO	CONFIGURE DRIVE	Field Control	0.00 to 100.00 % (h)	67.0%	fu	
212	RO	Operating Mode	DIAGNOSTICS	Jog/Slack	0 : Stop 1 : Stop 2 : Jog Sp. 1 3 : Jog Sp. 2 4 : Run 5 : Take Up Sp. 1 6 : Take Up Sp. 2 7 : Crawl	Stop	fw	Output
216	RW	PROG STOP LIMIT	SETUP PARAMETERS::STOP RATES	Stop Rates	0.0 to 600.0 Secs	60.0 Secs	g0	
217	RW	Stop Limit	SETUP PARAMETERS::STOP RATES	Stop Rates	0.0 to 600.0 Secs	60.0 Secs	g1	
218	RW	Jog Speed 1	SETUP PARAMETERS::JOG/SLACK	Jog/Slack	-100.00 to 100.00 %	20.00 %	g2	
219	RW	Jog Speed 2	SETUP PARAMETERS::JOG/SLACK	Jog/Slack	-100.00 to 100.00 %	-5.00 %	g3	
224	RW	Stall Trip Delay	SETUP PARAMETERS::CALIBRATION	Calibration	0.1 to 600.0 Secs	10.0 Secs	g8	
225	RW	Crawl Speed	SETUP PARAMETERS::JOG/SLACK	Jog/Slack	-100.00 to 100.00 %	10.00%	g9	
227	RW	AUX JOG	SETUP PARAMETERS::AUX I/O	Aux I/O	0 : Off 1 : On	On	gb	
228	RW	Mode	SETUP PARAMETERS::JOG/SLACK	Jog/Slack	0 : False 1 : True	FALSE	gc	
230	RW	Calibration	SYSTEM::CONFIGURE I/O::ANALOG INPUTS::ANIN 1 (A2)	Analog Input 1	-3.0000 to 3.0000	1.0000	ge	
231	RW	Max Value	SYSTEM::CONFIGURE I/O::ANALOG INPUTS::ANIN 1 (A2)	Analog Input 1	-300.00 to 300.00 %	100.00%	gf	
232	RW	Min Value	SYSTEM::CONFIGURE I/O::ANALOG INPUTS::ANIN 1 (A2)	Analog Input 1	-300.00 to 300.00 %	-100.00%	gg	

Table B-1 Parameters Listed by Tag Number Continued

Tag	R/W	Name	Keypad Menu	WB Block	Range	Factory Setting	MN	Notes
233	RW	Calibration	SYSTEM::CONFIGURE I/O::ANALOG IN-PUTS::ANIN 2 (A3)	Analog Input 2	-3.0000 to 3.0000	1.0000	gh	
234	RW	Max Value	SYSTEM::CONFIGURE I/O::ANALOG IN-PUTS::ANIN 2 (A3)	Analog Input 2	-300.00 to 300.00 %	100.00%	gi	
235	RW	Min Value	SYSTEM::CONFIGURE I/O::ANALOG IN-PUTS::ANIN 2 (A3)	Analog Input 2	-300.00 to 300.00 %	-100.00%	gj	
236	RW	Calibration	SYSTEM::CONFIGURE I/O::ANALOG IN-PUTS::ANIN 3 (A4)	Analog Input 3	-3.0000 to 3.0000	1.0000	gk	
237	RW	Max Value	SYSTEM::CONFIGURE I/O::ANALOG IN-PUTS::ANIN 3 (A4)	Analog Input 3	-300.00 to 300.00 %	100.00%	gl	
238	RW	Min Value	SYSTEM::CONFIGURE I/O::ANALOG IN-PUTS::ANIN 3 (A4)	Analog Input 3	-300.00 to 300.00 %	-100.00%	gm	
239	RW	Calibration	SYSTEM::CONFIGURE I/O::ANALOG IN-PUTS::ANIN 4 (A5)	Analog Input 4	-3.0000 to 3.0000	1.0000	gn	
240	RW	Max Value	SYSTEM::CONFIGURE I/O::ANALOG IN-PUTS::ANIN 4 (A5)	Analog Input 4	-300.00 to 300.00 %	100.00%	go	
241	RW	Min Value	SYSTEM::CONFIGURE I/O::ANALOG IN-PUTS::ANIN 4 (A5)	Analog Input 4	-300.00 to 300.00 %	-100.00%	gp	
242	RW	Calibration	SYSTEM::CONFIGURE I/O::ANALOG IN-PUTS::ANIN 5 (A6)	Analog Input 5	-3.0000 to 3.0000	1.0000	gq	
243	RW	Max Value	SYSTEM::CONFIGURE I/O::ANALOG IN-PUTS::ANIN 5 (A6)	Analog Input 5	-300.00 to 300.00 %	200.00%	gr	
244	RW	Min Value	SYSTEM::CONFIGURE I/O::ANALOG IN-PUTS::ANIN 5 (A6)	Analog Input 5	-300.00 to 300.00 %	-200.00%	gs	
245	RW	% TO GET 10V	SYSTEM::CONFIGURE I/O::ANALOG OUT-PUTS::ANOUT 1 (A7)	Analog Output 1	-300.00 to 300.00 %	100.00%	gt	
246	RW	Destination Tag	SYSTEM::CONFIGURE I/O::ANALOG IN-PUTS::ANIN 1 (A2)	Analog Input 1	0 to 549	100	gu	2, 3
247	RW	Destination Tag	SYSTEM::CONFIGURE I/O::ANALOG IN-PUTS::ANIN 5 (A6)	Analog Input 5	0 to 549	301	gv	2, 3
248	RW	% TO GET 10V	SYSTEM::CONFIGURE I/O::ANALOG OUT-PUTS::ANOUT 2 (A8)	Analog Output 2	-300.00 to 300.00 %	100.00%	gw	
249	RW	Destination Tag	SYSTEM::CONFIGURE I/O::ANALOG IN-PUTS::ANIN 3 (A4)	Analog Input 3	0 to 549	5	gx	2, 3
250	RW	Destination Tag	SYSTEM::CONFIGURE I/O::ANALOG IN-PUTS::ANIN 4 (A5)	Analog Input 4	0 to 549	48	gy	2, 3
251	RW	Source Tag	SYSTEM::CONFIGURE I/O::ANALOG OUT-PUTS::ANOUT 1 (A7)	Analog Output 1	0 to 549	62	gz	2, 3
252	RW	Source Tag	SYSTEM::CONFIGURE I/O::ANALOG OUT-PUTS::ANOUT 2 (A8)	Analog Output 2	0 to 549	63	h0	2, 3
253	RW	Take Up 1	SETUP PARAMETERS::JOG/SLACK	Jog/Slack	-100.00 to 100.00 %	5.00%	h1	
254	RW	Take Up 2	SETUP PARAMETERS::JOG/SLACK	Jog/Slack	-100.00 to 100.00 %	-5.00%	h2	
255	RW	Reset Value	SETUP PARAMETERS::RAISE/LOWER	Raise/Lower	-300.00 to 300.00 %	0.00%	h3	
256	RW	Increase Rate	SETUP PARAMETERS::RAISE/LOWER	Raise/Lower	0.1 to 600.0 Secs	10.0 Secs	h4	
257	RW	Decrease Rate	SETUP PARAMETERS::RAISE/LOWER	Raise/Lower	0.1 to 600.0 Secs	10.0 Secs	h5	
258	RW	Min Value	SETUP PARAMETERS::RAISE/LOWER	Raise/Lower	-300.00 to 300.00 %	-100.00%	h6	
259	RW	Max Value	SETUP PARAMETERS::RAISE/LOWER	Raise/Lower	-300.00 to 300.00 %	100.00%	h7	
260	RW	Raise/Lower Dest	SYSTEM::CONFIGURE I/O::BLOCK DIAGRAM	Raise/Lower Output	0 to 549	0	h8	
261	RW	Raise Input	SETUP PARAMETERS::RAISE/LOWER	Raise/Lower	0 : False 1 : True	FALSE	h9	
262	RW	Lower Input	SETUP PARAMETERS::RAISE/LOWER	Raise/Lower	0 : False 1 : True	FALSE	ha	
263	RW	Stall Threshold	SETUP PARAMETERS::CALIBRATION	Calibration	0.00 to 200.00 %	95.00%	hb	
264	RO	Raise/Lower O/P	DIAGNOSTICS	Raise/Lower	xxx.xx %	0.00%	hc	Output
266	RW	% S-RAMP	SETUP PARAMETERS::RAMPS	Ramps	0.00 to 100.00 %	2.50%	he	
268	RW	Mode	SETUP PARAMETERS::SPEED LOOP::AD-VANCED::ADAPTION	Advanced	0 to 3	0	hg	
269	RW	SPD BRK1 (LOW)	SETUP PARAMETERS::SPEED LOOP::AD-VANCED::ADAPTION	Advanced	0.00 to 100.00 %	1.00%	hh	
270	RW	SPD BRK2 (HIGH)	SETUP PARAMETERS::SPEED LOOP::AD-VANCED::ADAPTION	Advanced	0.00 to 100.00 %	5.00%	hi	
271	RW	PROP. GAIN	SETUP PARAMETERS::SPEED LOOP::AD-VANCED::ADAPTION	Advanced	0.00 to 200.00	5.00	hj	

Table B-1 Parameters Listed by Tag Number Continued

Tag	R/W	Name	Keypad Menu	WB Block	Range	Factory Setting	MN	Notes
272	RW	SPD.INT.TIME	SETUP PARAMETERS::SPEED LOOP::ADVANCED::ADAPTION	Advanced	0.001 to 30.000 Secs	0.500 Secs	hk	
273	RW	POS. LOOP P GAIN	SETUP PARAMETERS::SPEED LOOP::ADVANCED	Advanced	-200.00 to 200.00 %	0.00%	hl	4
274	RW	I GAIN IN RAMP	SETUP PARAMETERS::SPEED LOOP::ADVANCED	Advanced	0.0000 to 2.0000	1.0000	hm	
284	RW	ZERO SPD. LEVEL	SETUP PARAMETERS::SPEED LOOP::ADVANCED::ZERO SPD. QUENCH	Advanced	0.00 to 200.00 %	0.50%	hw	
285	RW	ZERO IAD LEVEL	SETUP PARAMETERS::SPEED LOOP::ADVANCED::ZERO SPD. QUENCH	Advanced	0.00 to 200.00 %	1.50%	hx	
286	RW	RAMPING THRESH.	SETUP PARAMETERS::RAMPS	Ramps	0.00 to 100.00 %	0.50%	hy	
287	RW	Auto Reset	SETUP PARAMETERS::RAMPS	Ramps	0 : Disabled 1 : Enabled	Enabled	hz	
288	RW	External Reset	SETUP PARAMETERS::RAMPS	Ramps	0 : Disabled 1 : Enabled	Disabled	i0	
289	RW	Setpoint 1	SETUP PARAMETERS::SPEED LOOP::SETPOINTS	Speed Loop	-105.00 to 105.00 %	0.00%	i1	
290	RO	Setpoint 2 (A3)	SETUP PARAMETERS::SPEED LOOP::SETPOINTS	Speed Loop	xxx.xx %	0.00%	i2	Output
291	RW	Setpoint 3	SETUP PARAMETERS::SPEED LOOP::SETPOINTS	Speed Loop	-105.00 to 105.00 %	0.00%	i3	
292	RW	SIGN 0	SETUP PARAMETERS::SETPOINT SUM 1	Setpoint Sum 1	0 : Negative 1 : Positive	Positive	i4	
293	RW	RAMP O/P DEST	SYSTEM::CONFIGURE I/O::BLOCK DIAGRAM	Ramp Output	0 to 549	291	i5	2, 3
294	RW	SPT SUM 1 DEST	SYSTEM::CONFIGURE I/O::BLOCK DIAGRAM	Setpoint Sum 1 Output	0 to 549	289	i6	2, 3
297	RO	Speed Error	DIAGNOSTICS	Diagnostics	xxx.xx %	-0.01%	i9	Output
298	RO	Current Feedback	DIAGNOSTICS	Diagnostics	xxx.xx %	0.00%	ia	Output
299	RO	Current Demand	DIAGNOSTICS	Diagnostics	xxx.xx %	0.00%	ib	Output
300	RO	FIELD I FBK.	DIAGNOSTICS	Diagnostics	xxx.xx %	0.00%	ic	Output
301	RW	POS. I CLAMP	SETUP PARAMETERS::CURRENT LOOP	Current Loop	-100.00 to 100.00 %	100.00%	id	
302	RW	Contactorm Delay	SETUP PARAMETERS::STOP RATES	Stop Rates	0.1 to 600.0 Secs	1.0 Secs	ie	
305	RW	Trip Reset	SETUP PARAMETERS::INHIBIT ALARMS	Alarms	0 : False 1 : True	TRUE	ih	
306	RW	Source Tag	SETUP PARAMETERS::STANDSTILL	Standstill	0 to 549	89	ii	2, 3, 4
307	RW	External Reset	SETUP PARAMETERS::RAISE/LOWER	Raise/Lower	0 : False 1 : True	FALSE	ij	
308	RO	Tach Input	DIAGNOSTICS	Diagnostics	xxx.xx % (h)	0.0%	ik	Output
309	RW	Input 0	SETUP PARAMETERS::SETPOINT SUM 1	Setpoint Sum 1	-200.00 to 200.00 %	0.00%	il	
329	RW	GROUP ID (GID)	SERIAL LINKS::SYSTEM PORT (P3)::P3 SETUP::BISYNCH SUPPORT	System Port P3	0x0000 to 0x0007	0x0000	j5	
330	RW	UNIT ID (UID)	SERIAL LINKS::SYSTEM PORT (P3)::P3 SETUP::BISYNCH SUPPORT	System Port P3	0x0000 to 0x000F	0x0000	j6	
332	RW	Error Report	SERIAL LINKS::SYSTEM PORT (P3)::P3 SETUP::BISYNCH SUPPORT	System Port P3	0x0000 to 0xFFFF	0x00C0	j8	1
337	RO	Thermistor State	ALARM STATUS	Unallocated	0 : False 1 : True	False	jd	Output
354	RW	Parameter Save	PARAMETER SAVE	Unallocated	Up To Action Requested		ju	1
355	RW	Ramp Rate	SETUP PARAMETERS::JOG/SLACK	Jog/Slack	0.1 to 600.0 Secs	1.0 Secs	jv	
357	RW	Max Demand	SETUP PARAMETERS::SPEED LOOP::SETPOINTS	Speed Loop	0.00 to 105.00 %	105.00%	jx	
358	RW	Min Demand	SETUP PARAMETERS::SPEED LOOP::SETPOINTS	Speed Loop	-105.00 to 105.00 %	-105.00%	jy	
359	RW	Inverted	SYSTEM::CONFIGURE I/O::DIGITAL OUTPUTS::DIGOUT 1 (B5)	Digout 1 (B5)	0 : False 1 : True	FALSE	jz	
360	RW	Inverted	SYSTEM::CONFIGURE I/O::DIGITAL OUTPUTS::DIGOUT 2 (B6)	Digout 2 (B6)	0 : False 1 : True	FALSE	k0	
361	RW	Inverted	SYSTEM::CONFIGURE I/O::DIGITAL OUTPUTS::DIGOUT 3 (B7)	Digout 3 (B7)	0 : False 1 : True	FALSE	k1	
362	RW	Modulus	SYSTEM::CONFIGURE I/O::ANALOG OUTPUTS::ANOUT 1 (A7)	Analog Output 1	0 : False 1 : True	FALSE	k2	
363	RW	Modulus	SYSTEM::CONFIGURE I/O::ANALOG OUTPUTS::ANOUT 2 (A8)	Analog Output 2	0 : False 1 : True	FALSE	k3	
364	RW	Source Tag	SYSTEM::CONFIGURE I/O::INTERNAL LINKS::LINK 1	Link 1	0 to 549	0	k4	2, 3
365	RW	Destination Tag	SYSTEM::CONFIGURE I/O::INTERNAL LINKS::LINK 1	Link 1	0 to 549	0	k5	2, 3

Table B-1 Parameters Listed by Tag Number Continued

Tag	R/W	Name	Keypad Menu	WB Block	Range	Factory Setting	MN	Notes
366	RW	Source Tag	SYSTEM::CONFIGURE I/O::INTERNAL LINKS::LINK 2	Link 2	0 to 549	0	k6	2, 3
367	RW	Destination Tag	SYSTEM::CONFIGURE I/O::INTERNAL LINKS::LINK 2	Link 2	0 to 549	0	k7	2, 3
368	RW	Source Tag	SYSTEM::CONFIGURE I/O::INTERNAL LINKS::LINK 3	Link 3	0 to 549	0	k8	2, 3
369	RW	Destination Tag	SYSTEM::CONFIGURE I/O::INTERNAL LINKS::LINK 3	Link 3	0 to 549	0	k9	2, 3
370	RW	Source Tag	SYSTEM::CONFIGURE I/O::INTERNAL LINKS::LINK 4	Link 4	0 to 549	0	ka	2, 3
371	RW	Destination Tag	SYSTEM::CONFIGURE I/O::INTERNAL LINKS::LINK 4	Link 4	0 to 549	0	kb	2, 3
374	RO	System Reset	DIAGNOSTICS	Unallocated	0 : False 1 : True	True	ke	Output
375	RW	Limit	SETUP PARAMETERS::SETPOINT SUM 1	Setpoint Sum 1	0.00 to 200.00 %	105.00%	kf	
376	RO	Drive Running	DIAGNOSTICS	Unallocated	0 : False 1 : True	False	kg	Output
400	RW	PID O/P DEST	SYSTEM::CONFIGURE I/O::BLOCK DIAGRAM	PID Output	0 to 549	0	l4	2, 3
401	RW	DERIVATIVE TC	SETUP PARAMETERS::SPECIAL BLOCKS::PID	PID	0.000 to 10.000 Secs	0.000Secs	l5	
402	RW	INT.TIME.CONST	SETUP PARAMETERS::SPECIAL BLOCKS::PID	PID	0.01 to 100.00 Secs	5.00 Secs	l6	
403	RW	FILTER T.C.	SETUP PARAMETERS::SPECIAL BLOCKS::PID	PID	0.000 to 10.000 Secs	0.100 Secs	l7	
404	RW	PROP. GAIN	SETUP PARAMETERS::SPECIAL BLOCKS::PID	PID	0.0 to 100.0	1.0	l8	
405	RW	Positive Limit	SETUP PARAMETERS::SPECIAL BLOCKS::PID	PID	0.00 to 105.00 %	100.00%	l9	
406	RW	Negative Limit	SETUP PARAMETERS::SPECIAL BLOCKS::PID	PID	-105.00 to 0.00 %	-100.00%	la	
407	RW	O/P SCALER(TRIM)	SETUP PARAMETERS::SPECIAL BLOCKS::PID	PID	-3.0000 to 3.0000	0.2000	lb	
408	RW	Enable	SETUP PARAMETERS::SPECIAL BLOCKS::PID	PID	0 : Disabled 1 : Enabled	Enabled	lc	
409	RW	INT. DEFEAT	SETUP PARAMETERS::SPECIAL BLOCKS::PID	PID	0 : Off 1 : On	Off	ld	
410	RW	Input 1	SETUP PARAMETERS::SPECIAL BLOCKS::PID	PID	-300.00 to 300.00 %	0.00%	le	
411	RW	Input 2	SETUP PARAMETERS::SPECIAL BLOCKS::PID	PID	-300.00 to 300.00 %	0.00%	lf	
412	RW	Ratio 1	SETUP PARAMETERS::SPECIAL BLOCKS::PID	PID	-3.0000 to 3.0000	1.0000	lg	
413	RW	Ratio 2	SETUP PARAMETERS::SPECIAL BLOCKS::PID	PID	-3.0000 to 3.0000	1.0000	lh	
414	RW	Divider 2	SETUP PARAMETERS::SPECIAL BLOCKS::PID	PID	-3.0000 to 3.0000	1.0000	li	
415	RO	PID Error	DIAGNOSTICS	PID	xxx.xx %	0.00%	lj	Output
416	RO	PID Clamped	DIAGNOSTICS	PID	0 : False 1 : True	False	lk	Output
417	RO	PID Output	DIAGNOSTICS	PID	xxx.xx %	0.00%	ll	Output
418	RW	Divider 1	SETUP PARAMETERS::SPECIAL BLOCKS::PID	PID	-3.0000 to 3.0000	1.0000	lm	
419	RW	Divider 1	SETUP PARAMETERS::SETPOINT SUM 1	Setpoint Sum 1	-3.0000 to 3.0000	1.0000	ln	
420	RW	Divider 0	SETUP PARAMETERS::SETPOINT SUM 1	Setpoint Sum 1	-3.0000 to 3.0000	1.0000	lo	
421	RW	MAIN CURR. LIMIT	SETUP PARAMETERS::CURRENT LOOP	Current Loop	0.00 to 200.00 %	200.00%	lp	
422	RW	Reset Value	SETUP PARAMETERS::RAMPS	Ramps	-300.00 to 300.00 %	0.00%	lq	
423	RW	Input 2	SETUP PARAMETERS::SETPOINT SUM 1	Setpoint Sum 1	-200.00 to 200.00 %	0.00%	lr	
454	RW	Source Tag	SYSTEM::CONFIGURE I/O::INTERNAL LINKS::LINK 5	Link 5	0 to 549	0	m m	2, 3
455	RW	Destination Tag	SYSTEM::CONFIGURE I/O::INTERNAL LINKS::LINK 5	Link 5	0 to 549	0	mn	2, 3
456	RW	Source Tag	SYSTEM::CONFIGURE I/O::INTERNAL LINKS::LINK 6	Link 6	0 to 549	0	mo	2, 3
457	RW	Destination Tag	SYSTEM::CONFIGURE I/O::INTERNAL LINKS::LINK 6	Link 6	0 to 549	0	mp	2, 3
458	RW	Source Tag	SYSTEM::CONFIGURE I/O::INTERNAL LINKS::LINK 7	Link 7	0 to 549	0	mq	2, 3
459	RW	Destination Tag	SYSTEM::CONFIGURE I/O::INTERNAL LINKS::LINK 7	Link 7	0 to 549	0	mr	2, 3
460	RW	Source Tag	SYSTEM::CONFIGURE I/O::INTERNAL LINKS::LINK 8	Link 8	0 to 549	0	ms	2, 3
461	RW	Destination Tag	SYSTEM::CONFIGURE I/O::INTERNAL LINKS::LINK 8	Link 8	0 to 549	0	mt	2, 3
464	RW	Offset	SYSTEM::CONFIGURE I/O::ANALOG OUTPUTS::ANOUT 1 (A7)	Analog Output 1	-100.00 to 100.00 %	0.00%	mw	
465	RW	Offset	SYSTEM::CONFIGURE I/O::ANALOG OUTPUTS::ANOUT 2 (A8)	Analog Output 2	-100.00 to 100.00 %	0.00%	mx	
467	RW	Source Tag	SYSTEM::CONFIGURE I/O::INTERNAL LINKS::LINK 9	Link 9	0 to 549	0	mz	2, 3

Table B-1 Parameters Listed by Tag Number Continued

Tag	R/W	Name	Keypad Menu	WB Block	Range	Factory Setting	MN	Notes
468	RW	Destination Tag	SYSTEM::CONFIGURE I/O::INTERNAL LINKS::LINK 9	Link 9	0 to 549	0	n0	2, 3
469	RW	Source Tag	SYSTEM::CONFIGURE I/O::INTERNAL LINKS::LINK 10	Link 10	0 to 549	0	n1	2, 3
470	RW	Destination Tag	SYSTEM::CONFIGURE I/O::INTERNAL LINKS::LINK 10	Link 10	0 to 549	0	n2	2, 3
472	RO	SPEED FBK STATE	ALARM STATUS	Unallocated	0 : False 1 : True	False	n4	Output
473	RW	Mode	SETUP PARAMETERS::SPECIAL BLOCKS::PID	PID	0 to 4	0	n5	
474	RW	MIN PROFILE GAIN	SETUP PARAMETERS::SPECIAL BLOCKS::PID	PID	0.00 to 100.00 %	20.00%	n6	
475	RO	Profiled Gain	SETUP PARAMETERS::SPECIAL BLOCKS::PID	PID	xxxx.x	0.0	n7	Output
493	RO	Output	SYSTEM::CONFIGURE I/O::ANALOG INPUTS::ANIN 2 (A3)	Analog Input 2	xxx.xx %	0.00%	np	Output, 2
494	RW	Destination Tag	SYSTEM::CONFIGURE I/O::DIGITAL INPUTS::DIGITAL INPUT C4	Dig in C4	0 to 549	496	nq	2, 3
495	RW	Destination Tag	SYSTEM::CONFIGURE I/O::DIGITAL INPUTS::DIGITAL INPUT C5	Dig in C5	0 to 549	497	nr	2, 3
496	RO	Jog/Slack	SETUP PARAMETERS::AUX I/O	Aux I/O	0 : Off 1 : On	Off	ns	Output
497	RO	Enable	SETUP PARAMETERS::AUX I/O	Aux I/O	0 : Off 1 : On	On	nt	Output
500	RW	TEC Option Type	SERIAL LINKS::TEC OPTION	Tec Option	0 : None 1 : Rs485 2 : Profibus Dp 3 : Link 4 : Device Net 5 : Can Open 6 : Lonworks 7 : Type 7	None	nw	
501	RW	TEC Option IN 1	SERIAL LINKS::TEC OPTION	Tec Option	-32768 to 32767	0	nx	
502	RW	TEC Option IN 2	SERIAL LINKS::TEC OPTION	Tec Option	-32768 to 32767	0	ny	
503	RW	TEC Option IN 3	SERIAL LINKS::TEC OPTION	Tec Option	-32768 to 32767	0	nz	
504	RW	TEC Option IN 4	SERIAL LINKS::TEC OPTION	Tec Option	-32768 to 32767	0	o0	
505	RW	TEC Option IN 5	SERIAL LINKS::TEC OPTION	Tec Option	-32768 to 32767	0	o1	
506	RO	TEC Option Fault	SERIAL LINKS::TEC OPTION	Tec Option	0 : None 1 : Parameter 2 : Type Mismatch 3 : Self Test 4 : Hardware 5 : Missing	None	o2	Output
507	RO	TEC Option VER	SERIAL LINKS::TEC OPTION	Tec Option	0x0000 to 0xFFFF	0x0000	o3	Output, 1
508	RO	TEC Option OUT 1	SERIAL LINKS::TEC OPTION	Tec Option	xxxxx	0	o4	Output, 1
509	RO	TEC Option OUT 2	SERIAL LINKS::TEC OPTION	Tec Option	xxxxx	0	o5	Output, 1
511	RW	Local Key Enable	SETUP PARAMETERS::OP STATION::SET UP	Op Station	0 : False 1 : True	TRUE	o7	
512	RW	Setpoint	SETUP PARAMETERS::OP STATION::SET UP	Op Station	0.00 to 100.00 %	0.00%	o8	1
513	RW	Jog Setpoint	SETUP PARAMETERS::OP STATION::SET UP	Op Station	0.00 to 100.00 %	5.00%	o9	1
514	RW	Ramp Accel Time	SETUP PARAMETERS::OP STATION::LOCAL RAMP	Op Station	0.1 to 600.0 Secs	10.0 Secs	oa	
515	RW	Ramp Decel Time	SETUP PARAMETERS::OP STATION::LOCAL RAMP	Op Station	0.1 to 600.0 Secs	10.0 Secs	ob	
516	RW	Forward	SETUP PARAMETERS::OP STATION::START UP VALUES	Op Station	0 : False 1 : True	TRUE	oc	
517	RW	Local	SETUP PARAMETERS::OP STATION::START UP VALUES	Op Station	0 : False 1 : True	TRUE	od	
518	RW	Program	SETUP PARAMETERS::OP STATION::START UP VALUES	Op Station	0 : False 1 : True	FALSE	oe	
519	RW	Setpoint	SETUP PARAMETERS::OP STATION::START UP VALUES	Op Station	0.00 to 100.00 %	0.00%	of	
520	RW	Jog Setpoint	SETUP PARAMETERS::OP STATION::START UP VALUES	Op Station	0.00 to 100.00 %	5.00%	og	
521	RW	NOM Motor Volts	CONFIGURE DRIVE	Calibration	100 to 875 Volts	500 Volts	oh	3
523	RW	Armature Current	CONFIGURE DRIVE	Calibration	2.0 to 15.0 AMPS	2.0 Amps	oj	3
524	RW	Field Current	CONFIGURE DRIVE	Calibration	0.2 to 4.0 AMPS	0.2 Amps	ok	3
525	RO	Coast Stop	DIAGNOSTICS	Stop Rates	0 : False 1 : True	FALSE	ol	Output
527	RO	Master Bridge	SETUP PARAMETERS::CURRENT LOOP	Current Loop	0 : Off 1 : On	Off	on	Output, 1

Table B-1 Parameters Listed by Tag Number Continued

Tag	R/W	Name	Keypad Menu	WB Block	Range	Factory Setting	MN	Notes
528	RO	Last Alarm	ALARM STATUS	Alarms	0x0000 : No Active Alarms 0x0001 : Over Speed 0x0002 : Missing Pulse 0x0004 : Field Over I 0x0008 : Heatsink Trip 0x0010 : Thermistor 0x0020 : Over Volts (VA) 0x0040 : SPD Feed back 0x0080 : Encoder Failed 0x0100 : Field Failed 0x0200 : 3 Phase Failed 0x0400 : Phase Lock 0x0800 : 5703 RCV Error 0x1000 : Stall Trip 0x2000 : Over I Trip 0xf005 : External Trip 0x8000 : Accts Failed 0xf001 : Autotune Error 0xf002 : Autotune Aborted 0xf200 : Config Enabled 0xf400 : No Keypad 0xf006 : Remote Trip 0xff05 : PCB Version 0xff06 : Product Code	No Active Alarms	oo	Output, 1
535	RW	REM.SEQ.ENABLE	SETUP PARAMETERS::AUX I/O	Aux I/O	0 : False, 1 : True	FALSE	ov	2
536	RW	REM.SEQUENCE	SETUP PARAMETERS::AUX I/O	Aux I/O	0x0000 to 0xFFFF	0x0000	ow	1
537	RO	SEQ Status	SETUP PARAMETERS::AUX I/O	Aux I/O	0x0000 to 0xFFFF	0x0C03	ox	Output
538	RO	Current FBK.Amps	DIAGNOSTICS	Current Loop	xxxx.x AMPS	0.0 Amps	oy	Output, 1, 3
539	RO	Field I FBK.AMPS	DIAGNOSTICS	Current Loop	xxxx.x AMPS	0.0 Amps	oz	Output, 1, 3
540	RW	REM Trip Inhibit	SETUP PARAMETERS::INHIBIT ALARMS	Alarms	0 : Enabled 1 : Inhibited	Enabled	p0	
541	RW	REM Trip Delay	SETUP PARAMETERS::CALIBRATION	Alarms	0.1 to 600.0 Secs	10.0 Secs	p1	
542	RO	Remote Trip	ALARM STATUS	Alarms	0 : False 1 : True	FALSE	p2	Output, 1
543	RW	Zero CAL Inputs	CONFIGURE DRIVE		Up To Action Requested		p3	1, 2, 3, 4
547	RW	SPD.FBK.FILTER	SETUP PARAMETERS::SPEED LOOP	Menus	0.000 to 1.000	0.000	p7	
549	RO	Speed LOOP O/P	DIAGNOSTICS	Speed Loop	-200 to 200 %	0.00%	p9	Output, 2
594	RW	CURR Decay Rate	SETUP PARAMETERS::STOP RATES	Stop Rates	0 to 200.00	0.00		
605	RO	ARM Volts FBK	DIAGNOSTICS	Unallocated		0 Volts		Output
617	RW	Field I Thresh	SETUP PARAMETERS::FIELD CONTROL	Field Control	0.00 to 100.00 %	80.00%		
618	RO	Up To Field	SETUP PARAMETERS::FIELD CONTROL	Field Control	0 : False 1 : True	False		Output
620	RW	Invert	SETUP PARAMETERS::RAMPS	Ramps	0 : False 1 : True	False		

Parameter Values Continued R/W: RO = Read Only, RW = Read / Write

Table B-2 Parameters Listed by Name

Tag	R/W	Name	Keypad Menu	WB Block	Range	Factory Setting	MN	Notes
266	RW	% S-RAMP	SETUP PARAMETERS::RAMPS	Ramps	0.00 to 100.00 %	2.50%	he	
245	RW	% TO GET 10V	SYSTEM::CONFIGURE I/O::ANALOG OUTPUTS::ANOUT 1 (A7)	Analog Output 1	-300.00 to 300.00 %	100.00%	gt	
248	RW	% TO GET 10V	SYSTEM::CONFIGURE I/O::ANALOG OUTPUTS::ANOUT 2 (A8)	Analog Output 2	-300.00 to 300.00 %	100.00%	gw	
111	RW	5703 RCV ERROR	SETUP PARAMETERS::INHIBIT ALARMS	Alarms	0 : Enabled 1 : Inhibited	Enabled	d3	
61	RO	ACTUAL NEG I LIM	DIAGNOSTICS	Diagnostics	xxx.xx % (h)	-90.0%	bp	Output
67	RO	ACTUAL POS I LIM	DIAGNOSTICS	Diagnostics	xxx.xx % (h)	90.00%	bv	Output
30	RW	Additional DEM	SETUP PARAMETERS::CURRENT LOOP	Current Loop	-200.00 to 200.00 %	0.00%	au	
204	RW	Aiming Point	SETUP PARAMETERS::INVERSE TIME	Inverse Time	0.00 to 103.00 %	103.00%	fo	2, 4
23	RW	Analog TACH CAL	SETUP PARAMETERS::CALIBRATION	Calibration	0.9800 to 1.1000	1.0000	an	
50	RO	ANIN 1 (A2)	DIAGNOSTICS	Analog Input 1	xxx.xx VOLTS	0.00V	be	Output
51	RO	ANIN 2 (A3)	DIAGNOSTICS	Analog Input 2	xxx.xx VOLTS	0.00V	bf	Output
52	RO	ANIN 3 (A4)	DIAGNOSTICS	Analog Input 3	xxx.xx VOLTS	0.00V	bg	Output
53	RO	ANIN 4 (A5)	DIAGNOSTICS	Analog Input 4	xxx.xx VOLTS	0.00V	bh	Output
54	RO	ANIN 5 (A6)	DIAGNOSTICS	Analog Input 5	xxx.xx VOLTS	10.00V	bi	Output
128	RW	ANOUT 1	SETUP PARAMETERS::AUX I/O	Aux I/O	-100.00 to 100.00 %	0.00%	dk	
55	RO	ANOUT 1 (A7)	DIAGNOSTICS	Analog Output 1	xxx.xx VOLTS (h)	0.00V	bj	Output
129	RW	ANOUT 2	SETUP PARAMETERS::AUX I/O	Aux I/O	-100.00 to 100.00 %	0.00%	dl	
56	RO	ANOUT 2 (A8)	DIAGNOSTICS	Analog Output 2	xxx.xx VOLTS (h)	0.00V	bk	Output
605	RO	ARM Volts FBK	DIAGNOSTICS	Unallocated		0 Volts		Output
523	RW	Armature Current	CONFIGURE DRIVE	Calibration	2.0 to 15.0 AMPS	2.0 Amps	oj	3
25	RW	Armature I (A9)	SETUP PARAMETERS::CALIBRATION	Calibration	0 : UNIPOLAR 1 : BIPOLAR	Bipolar	ap	
20	RW	Armature V CAL.	SETUP PARAMETERS::CALIBRATION	Calibration	0.9800 to 1.1000	1.0000	ak	
42	RO	At Current Limit	DIAGNOSTICS	Current Loop	0 : False 1 : True	False	b6	Output
79	RO	At Standstill	DIAGNOSTICS	Standstill	0 : False 1 : True	True	c7	Output
78	RO	At Zero Setpoint	DIAGNOSTICS	Standstill	0 : False 1 : True	True	c6	Output
77	RO	At Zero Speed	DIAGNOSTICS	Standstill	0 : False 1 : True	True	c5	Output
287	RW	Auto Reset	SETUP PARAMETERS::RAMPS	Ramps	0 : Disabled 1 : Enabled	Enabled	hz	
18	RO	Autotune	CONFIGURE DRIVE	Current Loop	0 : Off 1 : On	Off	ai	Output, 1
94	RW	AUX DIGOUT 1	SETUP PARAMETERS::AUX I/O	Aux I/O	0 : Off 1 : On	Off	cm	
95	RW	AUX DIGOUT 2	SETUP PARAMETERS::AUX I/O	Aux I/O	0 : Off 1 : On	Off	cn	
96	RW	AUX DIGOUT 3	SETUP PARAMETERS::AUX I/O	Aux I/O	0 : Off 1 : On	Off	co	
168	RW	Aux Enable	SETUP PARAMETERS::AUX I/O	Aux I/O	0 : Off 1 : On	On	eo	
227	RW	AUX JOG	SETUP PARAMETERS::AUX I/O	Aux I/O	0 : Off 1 : On	On	gb	
161	RW	AUX START	SETUP PARAMETERS::AUX I/O	Aux I/O	0 : Off 1 : On	On	eh	
60	RO	BACK EMF	DIAGNOSTICS	Calibration	xxx.xx % (h)	0.0%	bo	Output
192	RW	BEMF FBK LAG	SETUP PARAMETERS::FIELD CONTROL::FLD.CURRENT VARS::FLD.WEAK VARS	Field Control	10 to 5000	100	fc	
191	RW	BEMF FBK LEAD	SETUP PARAMETERS::FIELD CONTROL::FLD.CURRENT VARS::FLD.WEAK VARS	Field Control	10 to 5000	100	fb	
90	RW	Bipolar Clamps	SETUP PARAMETERS::CURRENT LOOP	Current Loop	0 : Disabled 1 : Enabled	Disabled	ci	
230	RW	Calibration	SYSTEM::CONFIGURE I/O::ANALOG INPUTS::ANIN 1 (A2)	Analog Input 1	-3.0000 to 3.0000	1.0000	ge	
233	RW	Calibration	SYSTEM::CONFIGURE I/O::ANALOG INPUTS::ANIN 2 (A3)	Analog Input 2	-3.0000 to 3.0000	1.0000	gh	
236	RW	Calibration	SYSTEM::CONFIGURE I/O::ANALOG INPUTS::ANIN 3 (A4)	Analog Input 3	-3.0000 to 3.0000	1.0000	gk	
239	RW	Calibration	SYSTEM::CONFIGURE I/O::ANALOG INPUTS::ANIN 4 (A5)	Analog Input 4	-3.0000 to 3.0000	1.0000	gn	
242	RW	Calibration	SYSTEM::CONFIGURE I/O::ANALOG INPUTS::ANIN 5 (A6)	Analog Input 5	-3.0000 to 3.0000	1.0000	gq	
121	RW	Change Password	PASSWORD		0x0000 to 0xFFFF	0x0000	dd	
525	RO	Coast Stop	DIAGNOSTICS	Stop Rates	0 : False 1 : True	FALSE	ol	Output
39	RW	Configure Enable	CONFIGURE DRIVE	Unallocated	0 : Disabled 1 : Enabled	Disabled	b3	2
4	RW	Constant Accel	SETUP PARAMETERS::RAMPS	Ramps	0 : Disabled 1 : Enabled	Enabled	a4	
83	RO	Contactors Closed	DIAGNOSTICS	Unallocated	0 : Off 1 : On	Off	cb	Output
302	RW	Contactors Delay	SETUP PARAMETERS::STOP RATES	Stop Rates	0.1 to 600.0 Secs	1.0 Secs	ie	
225	RW	Crawl Speed	SETUP PARAMETERS::JOG/SLACK	Jog/Slack	-100.00 to 100.00 %	10.00%	g9	

Table B-2 Parameters Listed by Name Continued

Tag	R/W	Name	Keypad Menu	WB Block	Range	Factory Setting	MN	Notes
15	RW	CUR.LIMIT/SCALER	CONFIGURE DRIVE	Current Loop	0.00 to 200.00 %	90.00%	af	
594	RW	CURR Decay Rate	SETUP PARAMETERS::STOP RATES	Stop Rates	0 to 200.00	0.00		
299	RO	Current Demand	DIAGNOSTICS	Diagnostics	xxx.xx %	0.00%	ib	Output
538	RO	Current FBK.Amps	DIAGNOSTICS	Current Loop	xxx.x AMPS	0.0 Amps	oy	Output, 1, 3
298	RO	Current Feedback	DIAGNOSTICS	Diagnostics	xxx.xx %	0.00%	ia	Output
131	RW	Deadband Width	SETUP PARAMETERS::SETPOINT SUM 1	Setpoint Sum 1	0.00 to 100.00 % (h)	0.0%	dn	
257	RW	Decrease Rate	SETUP PARAMETERS::RAISE/LOWER	Raise/Lower	0.1 to 600.0 Secs	10.0 Secs	h5	
199	RW	Delay	SETUP PARAMETERS::INVERSE TIME	Inverse Time	0.1 to 600.0 Secs	10.0 Secs	fj	2, 4
401	RW	DERIVATIVE TC	SETUP PARAMETERS::SPECIAL BLOCKS::PID	PID	0.000 to 10.000 Secs	0.000Secs	l5	
102	RW	Destination Tag	SYSTEM::CONFIGURE I/O::DIGITAL IN-PUTS::DIGIN 1 (C6)	Digital Input 1	0 to 549	90	cu	2, 3
105	RW	Destination Tag	SYSTEM::CONFIGURE I/O::DIGITAL IN-PUTS::DIGIN 2 (C7)	Digital Input 2	0 to 549	118	cx	2, 3
108	RW	Destination Tag	SYSTEM::CONFIGURE I/O::DIGITAL IN-PUTS::DIGIN 3 (C8)	Digital Input 3	0 to 549	119	d0	2, 3
135	RW	Destination Tag	SYSTEM::CONFIGURE I/O::CONFIGURE 5703	Scaled 5703 In-put	0 to 549	41	dr	2, 3
246	RW	Destination Tag	SYSTEM::CONFIGURE I/O::ANALOG IN-PUTS::ANIN 1 (A2)	Analog Input 1	0 to 549	100	gu	2, 3
247	RW	Destination Tag	SYSTEM::CONFIGURE I/O::ANALOG IN-PUTS::ANIN 5 (A6)	Analog Input 5	0 to 549	301	gv	2, 3
249	RW	Destination Tag	SYSTEM::CONFIGURE I/O::ANALOG IN-PUTS::ANIN 3 (A4)	Analog Input 3	0 to 549	5	gx	2, 3
250	RW	Destination Tag	SYSTEM::CONFIGURE I/O::ANALOG IN-PUTS::ANIN 4 (A5)	Analog Input 4	0 to 549	48	gy	2, 3
365	RW	Destination Tag	SYSTEM::CONFIGURE I/O::INTERNAL LINKS::LINK 1	Link 1	0 to 549	0	k5	2, 3
367	RW	Destination Tag	SYSTEM::CONFIGURE I/O::INTERNAL LINKS::LINK 2	Link 2	0 to 549	0	k7	2, 3
369	RW	Destination Tag	SYSTEM::CONFIGURE I/O::INTERNAL LINKS::LINK 3	Link 3	0 to 549	0	k9	2, 3
371	RW	Destination Tag	SYSTEM::CONFIGURE I/O::INTERNAL LINKS::LINK 4	Link 4	0 to 549	0	kb	2, 3
455	RW	Destination Tag	SYSTEM::CONFIGURE I/O::INTERNAL LINKS::LINK 5	Link 5	0 to 549	0	mn	2, 3
457	RW	Destination Tag	SYSTEM::CONFIGURE I/O::INTERNAL LINKS::LINK 6	Link 6	0 to 549	0	mp	2, 3
459	RW	Destination Tag	SYSTEM::CONFIGURE I/O::INTERNAL LINKS::LINK 7	Link 7	0 to 549	0	mr	2, 3
461	RW	Destination Tag	SYSTEM::CONFIGURE I/O::INTERNAL LINKS::LINK 8	Link 8	0 to 549	0	mt	2, 3
468	RW	Destination Tag	SYSTEM::CONFIGURE I/O::INTERNAL LINKS::LINK 9	Link 9	0 to 549	0	n0	2, 3
470	RW	Destination Tag	SYSTEM::CONFIGURE I/O::INTERNAL LINKS::LINK 10	Link 10	0 to 549	0	n2	2, 3
494	RW	Destination Tag	SYSTEM::CONFIGURE I/O::DIGITAL IN-PUTS::DIGITAL INPUT C4	Dig in C4	0 to 549	496	nq	2, 3
495	RW	Destination Tag	SYSTEM::CONFIGURE I/O::DIGITAL IN-PUTS::DIGITAL INPUT C5	Dig in C5	0 to 549	497	nr	2, 3
71	RO	DIGIN 1 (C6)	DIAGNOSTICS	Digital Input 1	0 : Off 1 : On	Off	bz	Output
72	RO	DIGIN 2 (C7)	DIAGNOSTICS	Digital Input 2	0 : Off 1 : On	Off	c0	Output
73	RO	DIGIN 3 (C8)	DIAGNOSTICS	Digital Input 3	0 : Off 1 : On	Off	c1	Output
69	RO	Digital Input C4	DIAGNOSTICS	Aux I/O	0 : Off 1 : On	Off	bx	Output
70	RO	Digital Input C5	DIAGNOSTICS	Aux I/O	0 : Off 1 : On	On	by	Output
74	RO	DIGOUT 1 (B5)	DIAGNOSTICS	Digout 1 (B5)	0 : Off 1 : On	On	c2	Output
75	RO	DIGOUT 2 (B6)	DIAGNOSTICS	Digout 2 (B6)	0 : Off 1 : On	On	c3	Output
76	RO	DIGOUT 3 (B7)	DIAGNOSTICS	Digout 3 (B7)	0 : Off 1 : On	Off	c4	Output
137	RW	Discontinuous	SETUP PARAMETERS::CURRENT LOOP	Current Loop	0.00 to 200.00 %	12.00%	dt	
420	RW	Divider 0	SETUP PARAMETERS::SETPOINT SUM 1	Setpoint Sum 1	-3.0000 to 3.0000	1.0000	lo	
418	RW	Divider 1	SETUP PARAMETERS::SPECIAL BLOCKS::PID	PID	-3.0000 to 3.0000	1.0000	lm	
419	RW	Divider 1	SETUP PARAMETERS::SETPOINT SUM 1	Setpoint Sum 1	-3.0000 to 3.0000	1.0000	ln	
414	RW	Divider 2	SETUP PARAMETERS::SPECIAL BLOCKS::PID	PID	-3.0000 to 3.0000	1.0000	li	

Table B-2 Parameters Listed by Name Continued

Tag	R/W	Name	Keypad Menu	WB Block	Range	Factory Setting	MN	Notes
84	RO	Drive Enable	DIAGNOSTICS	Diagnostics	0 : Disabled 1 : Enabled	Disabled	cc	Output
376	RO	Drive Running	DIAGNOSTICS	Unallocated	0 : False 1 : True	False	kg	Output
82	RO	Drive Start	DIAGNOSTICS	Diagnostics	0 : Off 1 : On	Off	ca	Output
177	RW	EMF GAIN	SETUP PARAMETERS::FIELD CONTROL::FLD.CURRENT VARS::FLD.WEAK VARS	Field Control	0.00 to 100.00	0.30	ex	
176	RW	EMF LAG	SETUP PARAMETERS::FIELD CONTROL::FLD.CURRENT VARS::FLD.WEAK VARS	Field Control	0.00 to 200.00	40.00	ew	
175	RW	EMF LEAD	SETUP PARAMETERS::FIELD CONTROL::FLD.CURRENT VARS::FLD.WEAK VARS	Field Control	0.10 to 50.00	2.00	ev	
408	RW	Enable	SETUP PARAMETERS::SPECIAL BLOCKS::PID	PID	0 : Disabled 1 : Enabled	Enabled	lc	
497	RO	Enable	SETUP PARAMETERS::AUX I/O	Aux I/O	0 : Off 1 : On	On	nt	Output
206	RO	Encoder	DIAGNOSTICS	Diagnostics	xxxx RPM	0 RPM	fq	Output
92	RW	Encoder Alarm	SETUP PARAMETERS::INHIBIT ALARMS	Alarms	0 : Enabled 1 : Inhibited	Enabled	ck	
24	RW	Encoder Lines	CONFIGURE DRIVE	Calibration	10 to 5000	1024	ao	2
22	RW	Encoder RPM	CONFIGURE DRIVE	Calibration	0 to 6000 RPM	1750 RPM	am	
49	RW	ENCODER SIGN	CONFIGURE DRIVE	Speed Loop	0 : Negative 1 : Positive	Positive	bd	2
120	RW	Enter Password	PASSWORD		0x0000 to 0xFFFF	0x0000	dc	1
332	RW	Error Report	SERIAL LINKS::SYSTEM PORT (P3)::P3 SETUP::BISYNCH SUPPORT	System Port P3	0x0000 to 0xFFFF	0x00C0	j8	1
288	RW	External Reset	SETUP PARAMETERS::RAMPS	Ramps	0 : Disabled 1 : Enabled	Disabled	i0	
307	RW	External Reset	SETUP PARAMETERS::RAISE/LOWER	Raise/Lower	0 : False 1 : True	FALSE	ij	
136	RW	Feed Forward	SETUP PARAMETERS::CURRENT LOOP	Current Loop	0.10 to 50.00	2.00	ds	4
524	RW	Field Current	CONFIGURE DRIVE	Calibration	0.2 to 4.0 AMPS	0.2 Amps	ok	3
183	RO	Field Demand	DIAGNOSTICS	Field Control	xxx.xx %	0.00%	f3	Output
170	RW	Field Enable	SETUP PARAMETERS::FIELD CONTROL	Field Control	0 : Disabled 1 : Enabled	Enabled	eq	2
169	RO	Field Enabled	DIAGNOSTICS	Field Control	0 : Disabled 1 : Enabled	Disabled	ep	Output
19	RW	Field Fail	SETUP PARAMETERS::INHIBIT ALARMS	Alarms	0 : Enabled 1 : Inhibited	Enabled	aj	
182	RW	Field I CAL.	SETUP PARAMETERS::CALIBRATION	Calibration	0.9800 to 1.1000	1.0000	f2	
300	RO	FIELD I FBK.	DIAGNOSTICS	Diagnostics	xxx.xx %	0.00%	ic	Output
539	RO	Field I FBK.AMPS	DIAGNOSTICS	Current Loop	xxxx.x AMPS	0.0 Amps	oz	Output, 1, 3
617	RW	Field I Thresh	SETUP PARAMETERS::FIELD CONTROL	Field Control	0.00 to 100.00 %	80.00%		
403	RW	FILTER T.C.	SETUP PARAMETERS::SPECIAL BLOCKS::PID	PID	0.000 to 10.000 Secs	0.100 Secs	l7	
186	RW	FLD. QUENCH MODE	SETUP PARAMETERS::FIELD CONTROL	Field Control	0 : Quench 1 : Standby	Quench	f6	
174	RW	FLD. WEAK ENABLE	SETUP PARAMETERS::FIELD CONTROL::FLD.CURRENT VARS::FLD.WEAK VARS	Field Control	0 : Disabled 1 : Enabled	Disabled	eu	2
209	RW	FLD.CTRL MODE	CONFIGURE DRIVE	Field Control	0 : Voltage Control 1 : Current Control	Voltage Control	ft	2
184	RO	FLD.FIRING ANGLE	DIAGNOSTICS	Field Control	xxx.xx DEG	0.00 Deg	f4	Output
185	RW	FLD.QUENCH DELAY	SETUP PARAMETERS::FIELD CONTROL	Field Control	0.0 to 600.0 Secs	0.0 Secs	f5	
210	RW	FLD.VOLTS RATIO	CONFIGURE DRIVE	Field Control	0.00 to 100.00 % (h)	67.0%	fu	
516	RW	Forward	SETUP PARAMETERS::OP STATION::START UP VALUES	Op Station	0 : False 1 : True	TRUE	oc	
37	RW	FULL MENUS	MENUS	Menus	0 : Disabled 1 : Enabled	Enabled	b1	
329	RW	GROUP ID (GiD)	SERIAL LINKS::SYSTEM PORT (P3)::P3 SETUP::BISYNCH SUPPORT	System Port P3	0x0000 to 0x0007	0x0000	j5	
122	RO	Health LED	DIAGNOSTICS	Alarms	0 : False 1 : True	True	de	Output
116	RO	Health Store	ALARM STATUS	Alarms	0x0000 to 0xFFFF	0x0000	d8	Output
115	RO	Health Word	ALARM STATUS	Alarms	0x0000 to 0xFFFF	0x0200	d7	Output
119	RW	I DMD. ISOLATE	SETUP PARAMETERS::CURRENT LOOP	Current Loop	0 : Disabled 1 : Enabled	Disabled	db	
274	RW	I GAIN IN RAMP	SETUP PARAMETERS::SPEED LOOP::ADVANCED	Advanced	0.0000 to 2.0000	1.0000	hm	
66	RO	IaDmd UNFILTERED	DIAGNOSTICS	Current Loop	xxx.xx % (h)	0.0%	bu	Output
65	RO	IaFbk UNFILTERED	DIAGNOSTICS	Current Loop	xxx.xx % (h)	0.0%	bt	Output
93	RW	IMAX BRK1(SPD1)	SETUP PARAMETERS::CURRENT PROFILE	Current Profile	0.00 to 200.00 % (h)	200.00%	cl	2
33	RW	IMAX BRK2(SPD2)	SETUP PARAMETERS::CURRENT PROFILE	Current Profile	0.00 to 200.00 % (h)	200.00%	ax	2
256	RW	Increase Rate	SETUP PARAMETERS::RAISE/LOWER	Raise/Lower	0.1 to 600.0 Secs	10.0 Secs	h4	
309	RW	Input 0	SETUP PARAMETERS::SETPOINT SUM 1	Setpoint Sum 1	-200.00 to 200.00 %	0.00%	il	
100	RW	Input 1	SETUP PARAMETERS::SETPOINT SUM 1	Setpoint Sum 1	-200.00 to 200.00 %	0.00%	cs	
410	RW	Input 1	SETUP PARAMETERS::SPECIAL BLOCKS::PID	PID	-300.00 to 300.00 %	0.00%	le	

Table B-2 Parameters Listed by Name Continued

Tag	R/W	Name	Keypad Menu	WB Block	Range	Factory Setting	MN	Notes
411	RW	Input 2	SETUP PARAMETERS::SPECIAL BLOCKS::PID	PID	-300.00 to 300.00 %	0.00%	lf	
423	RW	Input 2	SETUP PARAMETERS::SETPOINT SUM 1	Setpoint Sum 1	-200.00 to 200.00 %	0.00%	lr	
202	RW	INT. DEFEAT	SETUP PARAMETERS::SPEED LOOP	Speed Loop	0 : Off 1 : On	Off	fm	
409	RW	INT. DEFEAT	SETUP PARAMETERS::SPECIAL BLOCKS::PID	PID	0 : Off 1 : On	Off	ld	
17	RW	INT. GAIN	SETUP PARAMETERS::CURRENT LOOP	Current Loop	0.00 to 200.00	3.50	ah	
172	RW	INT. GAIN	SETUP PARAMETERS::FIELD CONTROL::FLD.CURRENT VARS	Field Control	0.00 to 100.00	1.28	es	
402	RW	INT.TIME.CONST	SETUP PARAMETERS::SPECIAL BLOCKS::PID	PID	0.01 to 100.00 Secs	5.00 Secs	l6	
203	RO	Inverse Time O/P	DIAGNOSTICS	Inverse Time	xxx.xx %	200.0%	fn	Output, 2, 4
620	RW	Invert	SETUP PARAMETERS::RAMPS	Ramps	0 : False 1 : True	False		
359	RW	Inverted	SYSTEM::CONFIGURE I/O::DIGITAL OUTPUTS::DIGOUT 1 (B5)	Digout 1 (B5)	0 : False 1 : True	FALSE	jz	
360	RW	Inverted	SYSTEM::CONFIGURE I/O::DIGITAL OUTPUTS::DIGOUT 2 (B6)	Digout 2 (B6)	0 : False 1 : True	FALSE	k0	
361	RW	Inverted	SYSTEM::CONFIGURE I/O::DIGITAL OUTPUTS::DIGOUT 3 (B7)	Digout 3 (B7)	0 : False 1 : True	FALSE	k1	
21	RW	IR Compensation	SETUP PARAMETERS::CALIBRATION	Calibration	0.00 to 100.00 %	0.00%	al	
513	RW	Jog Setpoint	SETUP PARAMETERS::OP STATION::SET UP	Op Station	0.00 to 100.00 %	5.00%	o9	1
520	RW	Jog Setpoint	SETUP PARAMETERS::OP STATION::START UP VALUES	Op Station	0.00 to 100.00 %	5.00%	og	
218	RW	Jog Speed 1	SETUP PARAMETERS::JOG/SLACK	Jog/Slack	-100.00 to 100.00 %	20.00 %	g2	
219	RW	Jog Speed 2	SETUP PARAMETERS::JOG/SLACK	Jog/Slack	-100.00 to 100.00 %	-5.00 %	g3	
496	RO	Jog/Slack	SETUP PARAMETERS::AUX I/O	Aux I/O	0 : Off 1 : On	Off	ns	Output
528	RO	Last Alarm	ALARM STATUS	Alarms	0x0000 : No Active Alarms 0x0001 : Over Speed 0x0002 : Missing Pulse 0x0004 : Field Over I 0x0008 : Heatsink Trip 0x0010 : Thermistor 0x0020 : Over Volts (VA) 0x0040 : SPD Feed back 0x0080 : Encoder Failed 0x0100 : Field Failed 0x0200 : 3 Phase Failed 0x0400 : Phase Lock 0x0800 : 5703 RCV Error 0x1000 : Stall Trip 0x2000 : Over I Trip 0xf005 : External Trip 0x8000 : Accts Failed 0xf001 : Autotune Error 0xf002 : Autotune Aborted 0xf200 : Config Enabled 0xf400 : No Keypad 0xf006 : Remote Trip 0xff05 : PCB Version 0xff06 : Product Code	No Active Alarms	oo	Output, 1
375	RW	Limit	SETUP PARAMETERS::SETPOINT SUM 1	Setpoint Sum 1	0.00 to 200.00 %	105.00%	kf	
517	RW	Local	SETUP PARAMETERS::OP STATION::START UP VALUES	Op Station	0 : False 1 : True	TRUE	od	
511	RW	Local Key Enable	SETUP PARAMETERS::OP STATION::SET UP	Op Station	0 : False 1 : True	TRUE	o7	
262	RW	Lower Input	SETUP PARAMETERS::RAISE/LOWER	Raise/Lower	0 : False 1 : True	FALSE	ha	
421	RW	MAIN CURR. LIMIT	SETUP PARAMETERS::CURRENT LOOP	Current Loop	0.00 to 200.00 %	200.00%	lp	
527	RO	Master Bridge	SETUP PARAMETERS::CURRENT LOOP	Current Loop	0 : Off 1 : On	Off	on	Output, 1
357	RW	Max Demand	SETUP PARAMETERS::SPEED LOOP::SETPOINTS	Speed Loop	0.00 to 105.00 %	105.00%	jx	
231	RW	Max Value	SYSTEM::CONFIGURE I/O::ANALOG INPUTS::ANIN 1 (A2)	Analog Input 1	-300.00 to 300.00 %	100.00%	gf	
234	RW	Max Value	SYSTEM::CONFIGURE I/O::ANALOG INPUTS::ANIN 2 (A3)	Analog Input 2	-300.00 to 300.00 %	100.00%	gi	
237	RW	Max Value	SYSTEM::CONFIGURE I/O::ANALOG INPUTS::ANIN 3 (A4)	Analog Input 3	-300.00 to 300.00 %	100.00%	gl	

Table B-2 Parameters Listed by Name Continued

Tag	R/W	Name	Keypad Menu	WB Block	Range	Factory Setting	MN	Notes
240	RW	Max Value	SYSTEM::CONFIGURE I/O::ANALOG INPUTS::ANIN 4 (A5)	Analog Input 4	-300.00 to 300.00 %	100.00%	go	
243	RW	Max Value	SYSTEM::CONFIGURE I/O::ANALOG INPUTS::ANIN 5 (A6)	Analog Input 5	-300.00 to 300.00 %	200.00%	gr	
259	RW	Max Value	SETUP PARAMETERS::RAISE/LOWER	Raise/Lower	-300.00 to 300.00 %	100.00%	h7	
178	RW	MAX VOLTS	SETUP PARAMETERS::FIELD CONTROL::FLD.CURRENT VARS::FLD.WEAK VARS	Field Control	0.00 to 100.00 %	100.00%	ey	
358	RW	Min Demand	SETUP PARAMETERS::SPEED LOOP::SETPOINTS	Speed Loop	-105.00 to 105.00 %	-105.00%	jy	
179	RW	MIN FLD.CURRENT	SETUP PARAMETERS::FIELD CONTROL::FLD.CURRENT VARS::FLD.WEAK VARS	Field Control	0.00 to 100.00 %	10.00%	ez	2
474	RW	MIN PROFILE GAIN	SETUP PARAMETERS::SPECIAL BLOCKS::PID	PID	0.00 to 100.00 %	20.00%	n6	
126	RW	MIN SPEED	SETUP PARAMETERS::RAMPS	Ramps	0.00 to 100.00 %	0.00%	di	
232	RW	Min Value	SYSTEM::CONFIGURE I/O::ANALOG INPUTS::ANIN 1 (A2)	Analog Input 1	-300.00 to 300.00 %	-100.00%	gg	
235	RW	Min Value	SYSTEM::CONFIGURE I/O::ANALOG INPUTS::ANIN 2 (A3)	Analog Input 2	-300.00 to 300.00 %	-100.00%	gj	
238	RW	Min Value	SYSTEM::CONFIGURE I/O::ANALOG INPUTS::ANIN 3 (A4)	Analog Input 3	-300.00 to 300.00 %	-100.00%	gm	
241	RW	Min Value	SYSTEM::CONFIGURE I/O::ANALOG INPUTS::ANIN 4 (A5)	Analog Input 4	-300.00 to 300.00 %	-100.00%	gp	
244	RW	Min Value	SYSTEM::CONFIGURE I/O::ANALOG INPUTS::ANIN 5 (A6)	Analog Input 5	-300.00 to 300.00 %	-200.00%	gs	
258	RW	Min Value	SETUP PARAMETERS::RAISE/LOWER	Raise/Lower	-300.00 to 300.00 %	-100.00%	h6	
130	RW	Mode	SERIAL LINKS::SYSTEM PORT (P3)::P3 SETUP	System Port P3	0 : Disabled 1 : 5703 Master 2 : 5703 Slave 3 : CELite (EIASCII)	0	dm	
228	RW	Mode	SETUP PARAMETERS::JOG/SLACK	Jog/Slack	0 : False 1 : True	FALSE	gc	
268	RW	Mode	SETUP PARAMETERS::SPEED LOOP::ADVANCED::ADAPTION	Advanced	0 to 3	0	hg	
473	RW	Mode	SETUP PARAMETERS::SPECIAL BLOCKS::PID	PID	0 to 4	0	n5	
43	RW	Modulus	SYSTEM::CONFIGURE I/O::DIGITAL OUTPUTS::DIGOUT 1 (B5)	Digout 1 (B5)	0 : False 1 : True	TRUE	b7	
44	RW	Modulus	SYSTEM::CONFIGURE I/O::DIGITAL OUTPUTS::DIGOUT 2 (B6)	Digout 2 (B6)	0 : False 1 : True	TRUE	b8	
45	RW	Modulus	SYSTEM::CONFIGURE I/O::DIGITAL OUTPUTS::DIGOUT 3 (B7)	Digout 3 (B7)	0 : False 1 : True	TRUE	b9	
362	RW	Modulus	SYSTEM::CONFIGURE I/O::ANALOG OUTPUTS::ANOUT 1 (A7)	Analog Output 1	0 : False 1 : True	FALSE	k2	
363	RW	Modulus	SYSTEM::CONFIGURE I/O::ANALOG OUTPUTS::ANOUT 2 (A8)	Analog Output 2	0 : False 1 : True	FALSE	k3	
48	RW	NEG. I CLAMP	SETUP PARAMETERS::CURRENT LOOP	Current Loop	-100.00 to 100.00 %	0.00%	bc	
88	RO	NEG. I CLAMP	DIAGNOSTICS	Diagnostics	xxx.xx % (h)	-90.0%	cg	Output
406	RW	Negative Limit	SETUP PARAMETERS::SPECIAL BLOCKS::PID	PID	-105.00 to 0.00 %	-100.00%	la	
521	RW	NOM Motor Volts	CONFIGURE DRIVE	Calibration	100 to 875 Volts	500 Volts	oh	3
407	RW	O/P SCALER(TRIM)	SETUP PARAMETERS::SPECIAL BLOCKS::PID	PID	-3.0000 to 3.0000	0.2000	lb	
464	RW	Offset	SYSTEM::CONFIGURE I/O::ANALOG OUTPUTS::ANOUT 1 (A7)	Analog Output 1	-100.00 to 100.00 %	0.00%	mw	
465	RW	Offset	SYSTEM::CONFIGURE I/O::ANALOG OUTPUTS::ANOUT 2 (A8)	Analog Output 2	-100.00 to 100.00 %	0.00%	mx	
212	RO	Operating Mode	DIAGNOSTICS	Jog/Slack	0 : Stop 1 : Stop 2 : Jog Sp. 1 3 : Jog Sp. 2 4 : Run 5 : Take Up Sp. 1 6 : Take Up Sp. 2 7 : Crawl	Stop	fw	Output

Table B-2 Parameters Listed by Name Continued

Tag	R/W	Name	Keypad Menu	WB Block	Range	Factory Setting	MN	Notes
493	RO	Output	SYSTEM::CONFIGURE I/O::ANALOG INPUTS::ANIN 2 (A3)	Analog Input 2	xxx.xx %	0.00%	np	Output, 2
188	RW	Over Speed Level	SETUP PARAMETERS::CALIBRATION	Calibration	0.00 to 200.00 %	125.00%	f8	4
198	RW	P3 Baud Rate	SERIAL LINKS::SYSTEM PORT (P3)::P3 SETUP		0:300 1:600 2:1200 3:2400 4:4800 5:9600 6:19200	9600	fi	2
354	RW	Parameter Save	PARAMETER SAVE	Unallocated	Up To Action Requested		ju	1
123	RW	Peek Data	SYSTEM::PEEK		0x0000 to 0xFFFF	0x0078	df	
124	RW	Peek Scale	SYSTEM::PEEK		-300.00 to 300.00	8.00	dg	
416	RO	PID Clamped	DIAGNOSTICS	PID	0 : False 1 : True	False	lk	Output
415	RO	PID Error	DIAGNOSTICS	PID	xxx.xx %	0.00%	lj	Output
400	RW	PID O/P DEST	SYSTEM::CONFIGURE I/O::BLOCK DIAGRAM	PID Output	0 to 549	0	l4	2, 3
417	RO	PID Output	DIAGNOSTICS	PID	xxx.xx %	0.00%	ll	Output
87	RO	POS. I CLAMP	DIAGNOSTICS	Diagnostics	xxx.xx % (h)	90.0%	cf	Output
301	RW	POS. I CLAMP	SETUP PARAMETERS::CURRENT LOOP	Current Loop	-100.00 to 100.00 %	100.00%	id	
273	RW	POS. LOOP P GAIN	SETUP PARAMETERS::SPEED LOOP::ADVANCED	Advanced	-200.00 to 200.00 %	0.00%	hl	4
405	RW	Positive Limit	SETUP PARAMETERS::SPECIAL BLOCKS::PID	PID	0.00 to 105.00 %	100.00%	l9	
475	RO	Profiled Gain	SETUP PARAMETERS::SPECIAL BLOCKS::PID	PID	xxxx.x	0.0	n7	Output
91	RW	PROG STOP I LIM	SETUP PARAMETERS::STOP RATES	Stop Rates	0.00 to 200.00 %	100.00%	cj	
216	RW	PROG STOP LIMIT	SETUP PARAMETERS::STOP RATES	Stop Rates	0.0 to 600.0 Secs	60.0 Secs	g0	
26	RW	PROG Stop Time	SETUP PARAMETERS::STOP RATES	Stop Rates	0.1 to 600.0 Secs	0.1 Secs	aq	
518	RW	Program	SETUP PARAMETERS::OP STATION::START UP VALUES	Op Station	0 : False 1 : True	FALSE	oe	
80	RO	Program Stop	DIAGNOSTICS	Stop Rates	0 : False 1 : True	False	c8	Output
16	RW	PROP. GAIN	SETUP PARAMETERS::CURRENT LOOP	Current Loop	0.00 to 200.00	45.00	ag	
173	RW	PROP. GAIN	SETUP PARAMETERS::FIELD CONTROL::FLD.CURRENT VARS	Field Control	0.00 to 100.00	0.10	et	
271	RW	PROP. GAIN	SETUP PARAMETERS::SPEED LOOP::ADVANCED::ADAPTION	Advanced	0.00 to 200.00	5.00	hj	
404	RW	PROP. GAIN	SETUP PARAMETERS::SPECIAL BLOCKS::PID	PID	0.0 to 100.0	1.0	l8	
261	RW	Raise Input	SETUP PARAMETERS::RAISE/LOWER	Raise/Lower	0 : False 1 : True	FALSE	h9	
260	RW	Raise/Lower Dest	SYSTEM::CONFIGURE I/O::BLOCK DIAGRAM	Raise/Lower Output	0 to 549	0	h8	
264	RO	Raise/Lower O/P	DIAGNOSTICS	Raise/Lower	xxx.xx %	0.00%	hc	Output
2	RW	Ramp Accel Time	SETUP PARAMETERS::RAMPS	Ramps	0.1 to 600.0 Secs	10.0 Secs	a2	
514	RW	Ramp Accel Time	SETUP PARAMETERS::OP STATION::LOCAL RAMP	Op Station	0.1 to 600.0 Secs	10.0 Secs	oa	
3	RW	Ramp Decel Time	SETUP PARAMETERS::RAMPS	Ramps	0.1 to 600.0 Secs	10.0 Secs	a3	
515	RW	Ramp Decel Time	SETUP PARAMETERS::OP STATION::LOCAL RAMP	Op Station	0.1 to 600.0 Secs	10.0 Secs	ob	
118	RW	Ramp Hold	SETUP PARAMETERS::RAMPS	Ramps	0 : Off 1 : On	Off	da	
5	RW	Ramp Input	SETUP PARAMETERS::RAMPS	Ramps	-105.00 to 105.00 %	0.00%	a5	
293	RW	RAMP O/P DEST	SYSTEM::CONFIGURE I/O::BLOCK DIAGRAM	Ramp Output	0 to 549	291	i5	2, 3
85	RO	Ramp Output	DIAGNOSTICS	Ramps	xxx.xx %	0.00%	cd	Output
355	RW	Ramp Rate	SETUP PARAMETERS::JOG/SLACK	Jog/Slack	0.1 to 600.0 Secs	1.0 Secs	ju	
113	RO	Ramping	DIAGNOSTICS	Ramps	0 : False 1 : True	False	d5	Output
286	RW	RAMPING THRESH.	SETUP PARAMETERS::RAMPS	Ramps	0.00 to 100.00 %	0.50%	hy	
200	RW	Rate	SETUP PARAMETERS::INVERSE TIME	Inverse Time	0.1 to 600.0 Secs	60.0 Secs	fk	2, 4
208	RW	Ratio 0	SETUP PARAMETERS::SETPOINT SUM 1	Setpoint Sum 1	-3.0000 to 3.0000	1.0000	fs	
6	RW	Ratio 1	SETUP PARAMETERS::SETPOINT SUM 1	Setpoint Sum 1	-3.0000 to 3.0000	1.0000	a6	
412	RW	Ratio 1	SETUP PARAMETERS::SPECIAL BLOCKS::PID	PID	-3.0000 to 3.0000	1.0000	lg	
413	RW	Ratio 2	SETUP PARAMETERS::SPECIAL BLOCKS::PID	PID	-3.0000 to 3.0000	1.0000	lh	
7	RW	Ratio 2 (A3)	SETUP PARAMETERS::SPEED LOOP::SETPOINTS	Speed Loop	-3.0000 to 3.0000	.0000	a7	
187	RO	Raw Input	SERIAL LINKS::SYSTEM PORT (P3)::P3 SETUP::5703 SUPPORT	5703	xxx.xx %	0.00%	f7	Output
125	RO	Ready	DIAGNOSTICS	Alarms	0 : False 1 : True	False	dh	Output
201	RW	Regen Mode	SETUP PARAMETERS::CURRENT LOOP	Current Loop	0 : 2Q (Non-regen) 1 : 4Q (Regen)	2Q(Non-regen)	fl	2
541	RW	REM Trip Delay	SETUP PARAMETERS::CALIBRATION	Alarms	0.1 to 600.0 Secs	10.0 Secs	p1	

Table B-2 Parameters Listed by Name Continued

Tag	R/W	Name	Keypad Menu	WB Block	Range	Factory Setting	MN	Notes
540	RW	REM Trip Inhibit	SETUP PARAMETERS::INHIBIT ALARMS	Alarms	0 : Enabled 1 : Inhibited	Enabled	p0	
535	RW	REM.SEQ.ENABLE	SETUP PARAMETERS::AUX I/O	Aux I/O	0 : False, 1 : True	FALSE	ov	2
536	RW	REM.SEQUENCE	SETUP PARAMETERS::AUX I/O	Aux I/O	0x0000 to 0xFFFF	0x0000	ow	1
542	RO	Remote Trip	ALARM STATUS	Alarms	0 : False 1 : True	FALSE	p2	Output, 1
255	RW	Reset Value	SETUP PARAMETERS::RAISE/LOWER	Raise/Lower	-300.00 to 300.00 %	0.00%	h3	
422	RW	Reset Value	SETUP PARAMETERS::RAMPS	Ramps	-300.00 to 300.00 %	0.00%	lq	
189	RO	Scaled Input	SERIAL LINKS::SYSTEM PORT (P3)::P3 SET-UP::5703 SUPPORT	5703	xxx.xx %	0.00%	f9	Output, 2
537	RO	SEQ Status	SETUP PARAMETERS::AUX I/O	Aux I/O	0x0000 to 0xFFFF	0x0C03	ox	Output
171	RW	Setpoint	SETUP PARAMETERS::FIELD CONTROL::FLD.CURRENT VARS	Field Control	0.00 to 100.00 %	100.00%	er	
512	RW	Setpoint	SETUP PARAMETERS::OP STATION::SET UP	Op Station	0.00 to 100.00 %	0.00%	o8	1
519	RW	Setpoint	SETUP PARAMETERS::OP STATION::START UP VALUES	Op Station	0.00 to 100.00 %	0.00%	of	
289	RW	Setpoint 1	SETUP PARAMETERS::SPEED LOOP::SET-POINTS	Speed Loop	-105.00 to 105.00 %	0.00%	i1	
290	RO	Setpoint 2 (A3)	SETUP PARAMETERS::SPEED LOOP::SET-POINTS	Speed Loop	xxx.xx %	0.00%	i2	Output
291	RW	Setpoint 3	SETUP PARAMETERS::SPEED LOOP::SET-POINTS	Speed Loop	-105.00 to 105.00 %	0.00%	i3	
41	RW	Setpoint 4	SETUP PARAMETERS::SPEED LOOP::SET-POINTS	Speed Loop	-105.00 to 105.00 %	0.00%	b5	
132	RW	SETPT. RATIO	SERIAL LINKS::SYSTEM PORT (P3)::P3 SET-UP::5703 SUPPORT	5703	-3.0000 to 3.0000	0.0000	do	
133	RW	SETPT. SIGN	SERIAL LINKS::SYSTEM PORT (P3)::P3 SET-UP::5703 SUPPORT	5703	0 : Negative 1 : Positive	Positive	dp	
292	RW	SIGN 0	SETUP PARAMETERS::SETPOINT SUM 1	Setpoint Sum 1	0 : Negative 1 : Positive	Positive	i4	
8	RW	Sign 1	SETUP PARAMETERS::SETPOINT SUM 1	Setpoint Sum 1	0 : Negative 1 : Positive	Positive	a8	
9	RW	Sign 2 (A3)	SETUP PARAMETERS::SPEED LOOP::SET-POINTS	Speed Loop	0 : Negative 1 : Positive	Positive	a9	
97	RW	Source Tag	SYSTEM::CONFIGURE I/O::DIGITAL OUTPUTS::DIGOUT 1 (B5)	Digout 1 (B5)	0 to 549	77	cp	2, 3
98	RW	Source Tag	SYSTEM::CONFIGURE I/O::DIGITAL OUTPUTS::DIGOUT 2 (B6)	Digout 2 (B6)	0 to 549	122	cq	2, 3
99	RW	Source Tag	SYSTEM::CONFIGURE I/O::DIGITAL OUTPUTS::DIGOUT 3 (B7)	Digout 3 (B7)	0 to 549	125	cr	2, 3
134	RW	Source Tag	SYSTEM::CONFIGURE I/O::CONFIGURE 5703	5703	0 to 549	89	dq	2, 3
251	RW	Source Tag	SYSTEM::CONFIGURE I/O::ANALOG OUTPUTS::ANOUT 1 (A7)	Analog Output 1	0 to 549	62	gz	2, 3
252	RW	Source Tag	SYSTEM::CONFIGURE I/O::ANALOG OUTPUTS::ANOUT 2 (A8)	Analog Output 2	0 to 549	63	h0	2, 3
306	RW	Source Tag	SETUP PARAMETERS::STANDSTILL	Standstill	0 to 549	89	ii	2, 3, 4
364	RW	Source Tag	SYSTEM::CONFIGURE I/O::INTERNAL LINKS::LINK 1	Link 1	0 to 549	0	k4	2, 3
366	RW	Source Tag	SYSTEM::CONFIGURE I/O::INTERNAL LINKS::LINK 2	Link 2	0 to 549	0	k6	2, 3
368	RW	Source Tag	SYSTEM::CONFIGURE I/O::INTERNAL LINKS::LINK 3	Link 3	0 to 549	0	k8	2, 3
370	RW	Source Tag	SYSTEM::CONFIGURE I/O::INTERNAL LINKS::LINK 4	Link 4	0 to 549	0	ka	2, 3
454	RW	Source Tag	SYSTEM::CONFIGURE I/O::INTERNAL LINKS::LINK 5	Link 5	0 to 549	0	m m	2, 3
456	RW	Source Tag	SYSTEM::CONFIGURE I/O::INTERNAL LINKS::LINK 6	Link 6	0 to 549	0	mo	2, 3
458	RW	Source Tag	SYSTEM::CONFIGURE I/O::INTERNAL LINKS::LINK 7	Link 7	0 to 549	0	mq	2, 3
460	RW	Source Tag	SYSTEM::CONFIGURE I/O::INTERNAL LINKS::LINK 8	Link 8	0 to 549	0	ms	2, 3
467	RW	Source Tag	SYSTEM::CONFIGURE I/O::INTERNAL LINKS::LINK 9	Link 9	0 to 549	0	mz	2, 3
469	RW	Source Tag	SYSTEM::CONFIGURE I/O::INTERNAL LINKS::LINK 10	Link 10	0 to 549	0	n1	2, 3
32	RW	SPD BRK1 (LOW)	SETUP PARAMETERS::CURRENT PROFILE	Current Profile	0.00 to 100.00 % (h)	100.00%	aw	2

Table B-2 Parameters Listed by Name Continued

Tag	R/W	Name	Keypad Menu	WB Block	Range	Factory Setting	MN	Notes
269	RW	SPD BRK1 (LOW)	SETUP PARAMETERS::SPEED LOOP::ADVANCED::ADAPTION	Advanced	0.00 to 100.00 %	1.00%	hh	
31	RW	SPD BRK2 (HIGH)	SETUP PARAMETERS::CURRENT PROFILE	Current Profile	0.00 to 100.00 % (h)	100.00%	av	2
270	RW	SPD BRK2 (HIGH)	SETUP PARAMETERS::SPEED LOOP::ADVANCED::ADAPTION	Advanced	0.00 to 100.00 %	5.00%	hi	
547	RW	SPD.FBK.FILTER	SETUP PARAMETERS::SPEED LOOP	Menus	0.000 to 1.000	0.000	p7	
13	RW	SPD.INT.TIME	CONFIGURE DRIVE	Speed Loop	0.001 to 30.000 Secs	0.500 Secs	ad	
272	RW	SPD.INT.TIME	SETUP PARAMETERS::SPEED LOOP::ADVANCED::ADAPTION	Advanced	0.001 to 30.000 Secs	0.500 Secs	hk	
14	RW	SPD.PROP.GAIN	CONFIGURE DRIVE	Speed Loop	0.00 to 200.00	10	ae	
180	RW	SPDFBK ALM LEVEL	SETUP PARAMETERS::CALIBRATION	Calibration	0.00 to 100.00 % (h)	50.00%	f0	
89	RO	Speed Demand	DIAGNOSTICS	Stop Rates	xxx.xx %	0.00%	ch	Output
297	RO	Speed Error	DIAGNOSTICS	Diagnostics	xxx.xx %	-0.01%	i9	Output
81	RW	SPEED FBK ALARM	SETUP PARAMETERS::INHIBIT ALARMS	Alarms	0 : Enabled 1 : Inhibited	Enabled	c9	
47	RW	SPEED FBK SELECT	CONFIGURE DRIVE	Speed Loop	0 : Arm Volts Fbk 1 : Analog Tach 2 : Encoder 3 : Encoder/Analog	Arm Volts Fbk	bb 2	
472	RO	SPEED FBK STATE	ALARM STATUS	Unallocated	0 : False 1 : True	False	n4	Output
207	RO	Speed Feedback	DIAGNOSTICS	Diagnostics	xxx.xx %	0.01%	fr	Output
549	RO	Speed LOOP O/P	DIAGNOSTICS	Speed Loop	-200 to 200 %	0.00%	p9	Output, 2
63	RO	Speed Setpoint	DIAGNOSTICS	Speed Loop	xxx.xx %	0.00%	br	Output
294	RW	SPT SUM 1 DEST	SYSTEM::CONFIGURE I/O::BLOCK DIAGRAM	Setpoint Sum 1 Output	0 to 549	289	i6	2, 3
86	RO	SPT SUM OUTPUT	DIAGNOSTICS	Setpoint Sum 1	xxx.xx %	0.00%	ce	Output
263	RW	Stall Threshold	SETUP PARAMETERS::CALIBRATION	Calibration	0.00 to 200.00 %	95.00%	hb	
28	RW	Stall Trip	SETUP PARAMETERS::INHIBIT ALARMS	Alarms	0 : Enabled 1 : Inhibited	Inhibited	as	
112	RO	Stall Trip	ALARM STATUS	Alarms	0 : OK 1 : Failed	OK	d4	Output
224	RW	Stall Trip Delay	SETUP PARAMETERS::CALIBRATION	Calibration	0.1 to 600.0 Secs	10.0 Secs	g8	
11	RW	Standstill Logic	SETUP PARAMETERS::STANDSTILL	Standstill	0 : Disabled 1 : Enabled	Disabled	ab	
68	RO	Start (C3)	DIAGNOSTICS	Aux I/O	0 : Off 1 : On	Off	bw	Output
217	RW	Stop Limit	SETUP PARAMETERS::STOP RATES	Stop Rates	0.0 to 600.0 Secs	60.0 Secs	g1	
27	RW	Stop Time	SETUP PARAMETERS::STOP RATES	Stop Rates	0.1 to 600.0 Secs	10.0 Secs	ar	
29	RW	Stop Zero Speed	SETUP PARAMETERS::STOP RATES	Stop Rates	0.00 to 100.00 %	2.00%	at	
374	RO	System Reset	DIAGNOSTICS	Unallocated	0 : False 1 : True	True	ke	Output
308	RO	Tach Input	DIAGNOSTICS	Diagnostics	xxx.xx % (h)	0.0%	ik	Output
253	RW	Take Up 1	SETUP PARAMETERS::JOG/SLACK	Jog/Slack	-100.00 to 100.00 %	5.00%	h1	
254	RW	Take Up 2	SETUP PARAMETERS::JOG/SLACK	Jog/Slack	-100.00 to 100.00 %	-5.00%	h2	
506	RO	TEC Option Fault	SERIAL LINKS::TEC OPTION	Tec Option	0 : None 1 : Parameter 2 : Type Mismatch 3 : Self Test 4 : Hardware 5 : Missing	None	o2	Output
501	RW	TEC Option IN 1	SERIAL LINKS::TEC OPTION	Tec Option	-32768 to 32767	0	nx	
502	RW	TEC Option IN 2	SERIAL LINKS::TEC OPTION	Tec Option	-32768 to 32767	0	ny	
503	RW	TEC Option IN 3	SERIAL LINKS::TEC OPTION	Tec Option	-32768 to 32767	0	nz	
504	RW	TEC Option IN 4	SERIAL LINKS::TEC OPTION	Tec Option	-32768 to 32767	0	o0	
505	RW	TEC Option IN 5	SERIAL LINKS::TEC OPTION	Tec Option	-32768 to 32767	0	o1	
508	RO	TEC Option OUT 1	SERIAL LINKS::TEC OPTION	Tec Option	xxxxx	0	o4	Output, 1
509	RO	TEC Option OUT 2	SERIAL LINKS::TEC OPTION	Tec Option	xxxxx	0	o5	Output, 1
500	RW	TEC Option Type	SERIAL LINKS::TEC OPTION	Tec Option	0 : None 1 : Rs485 2 : Profibus Dp 3 : Link 4 : Device Net 5 : Can Open 6 : Lonworks 7 : Type 7	None	nw	
507	RO	TEC Option VER	SERIAL LINKS::TEC OPTION	Tec Option	0x0000 to 0xFFFF	0x0000	o3	Output, 1

Table B-2 Parameters Listed by Name Continued

Tag	R/W	Name	Keypad Menu	WB Block	Range	Factory Setting	MN	Notes
57	RO	Terminal Volts	DIAGNOSTICS	Calibration	xxx.xx % (h)	0.0%	bl	Output
337	RO	Thermistor State	ALARM STATUS	Unallocated	0 : False 1 : True	False	jd	Output
195	RW	Threshold (>)	SYSTEM::CONFIGURE I/O::DIGITAL OUTPUTS::DIGOUT 1 (B5)	Digout 1 (B5)	-300.00 to 300.00 %	0.00%	ff	2
196	RW	Threshold (>)	SYSTEM::CONFIGURE I/O::DIGITAL OUTPUTS::DIGOUT 2 (B6)	Digout 2 (B6)	-300.00 to 300.00 %	0.00%	fg	2
197	RW	Threshold (>)	SYSTEM::CONFIGURE I/O::DIGITAL OUTPUTS::DIGOUT 3 (B7)	Digout 3 (B7)	-300.00 to 300.00 %	0.00%	fh	2
305	RW	Trip Reset	SETUP PARAMETERS::INHIBIT ALARMS	Alarms	0 : False 1 : True	TRUE	ih	
181	RO	Unfil. Field FBK	DIAGNOSTICS	Calibration	xxx.xx %	0.00%	f1	Output
59	RO	UNFIL.ENCODER	DIAGNOSTICS	Calibration	xxxxx RPM	0 RPM	bn	Output
64	RO	UNFIL.SPD.ERROR	DIAGNOSTICS	Speed Loop	xxx.xx %	0.00%	bs	Output
62	RO	UNFIL.SPD.FBK	DIAGNOSTICS	Speed Loop	xxx.xx %	0.03%	bq	Output
58	RO	UNFIL.TACH INPUT	DIAGNOSTICS	Calibration	xxx.xx % (h)	0.0%	bm	Output
330	RW	UNIT ID (UID)	SERIAL LINKS::SYSTEM PORT (P3)::P3 SETUP::BISYNCH SUPPORT	System Port P3	0x0000 to 0x000F	0x0000	j6	
618	RO	Up To Field	SETUP PARAMETERS::FIELD CONTROL	Field Control	0 : False 1 : True	False		Output
104	RW	Value For False	SYSTEM::CONFIGURE I/O::DIGITAL INPUTS::DIGIN 1 (C6)	Digital Input 1	-300.00 to 300.00 %	0.00%	cw	
107	RW	Value For False	SYSTEM::CONFIGURE I/O::DIGITAL INPUTS::DIGIN 2 (C7)	Digital Input 2	-300.00 to 300.00 %	0.00%	cz	
110	RW	Value For False	SYSTEM::CONFIGURE I/O::DIGITAL INPUTS::DIGIN 3 (C8)	Digital Input 3	-300.00 to 300.00 %	0.00%	d2	
103	RW	Value For True	SYSTEM::CONFIGURE I/O::DIGITAL INPUTS::DIGIN 1 (C6)	Digital Input 1	-300.00 to 300.00 %	0.01%	cv	
106	RW	Value For True	SYSTEM::CONFIGURE I/O::DIGITAL INPUTS::DIGIN 2 (C7)	Digital Input 2	-300.00 to 300.00 %	0.01%	cy	
109	RW	Value For True	SYSTEM::CONFIGURE I/O::DIGITAL INPUTS::DIGIN 3 (C8)	Digital Input 3	-300.00 to 300.00 %	0.01%	d1	
155	RO	Version Number	SERIAL LINKS::SYSTEM PORT (P3)	Unallocated	0x0000 to 0xFFFF		eb	Output
543	RW	Zero CAL Inputs	CONFIGURE DRIVE		Up To Action Requested		p3	1, 2, 3, 4
285	RW	ZERO IAD LEVEL	SETUP PARAMETERS::SPEED LOOP::ADVANCED::ZERO SPD. QUENCH	Advanced	0.00 to 200.00 %	1.50%	hx	
284	RW	ZERO SPD. LEVEL	SETUP PARAMETERS::SPEED LOOP::ADVANCED::ZERO SPD. QUENCH	Advanced	0.00 to 200.00 %	0.50%	hw	
10	RW	Zero SPD. Offset	SETUP PARAMETERS::CALIBRATION	Calibration	-5.00 to 5.00 %	0.00%	aa	
12	RW	Zero Threshold	SETUP PARAMETERS::STANDSTILL	Standstill	0.00 to 100.00 %	2.00%	ac	

Parameter Values Continued R/W: RO = Read Only, RW = Read / Write

Table B-3 Parameters Listed by Keypad Menu

Tag	R/W	Name	Keypad Menu	WB Block	Range	Factory Setting	MN	Notes
116	RO	Health Store	ALARM STATUS	Alarms	0x0000 to 0xFFFF	0x0000	d8	Output
115	RO	Health Word	ALARM STATUS	Alarms	0x0000 to 0xFFFF	0x0200	d7	Output
528	RO	Last Alarm	ALARM STATUS	Alarms	0x0000 : No Active Alarms 0x0001 : Over Speed 0x0002 : Missing Pulse 0x0004 : Field Over I 0x0008 : Heatsink Trip 0x0010 : Thermistor 0x0020 : Over Volts (VA) 0x0040 : SPD Feed back 0x0080 : Encoder Failed 0x0100 : Field Failed 0x0200 : 3 Phase Failed 0x0400 : Phase Lock 0x0800 : 5703 RCV Error 0x1000 : Stall Trip 0x2000 : Over I Trip 0x005 : External Trip 0x8000 : Accts Failed 0xf001 : Autotune Error 0xf002 : Autotune Aborted 0xf200 : Config Enabled 0xf400 : No Keypad 0xf006 : Remote Trip 0xff05 : PCB Version 0xff06 : Product Code	No Active Alarms	oo	Output, 1
542	RO	Remote Trip	ALARM STATUS	Alarms	0 : False 1 : True	FALSE	p2	Output, 1
472	RO	SPEED FBK STATE	ALARM STATUS	Unallocated	0 : False 1 : True	False	n4	Output
112	RO	Stall Trip	ALARM STATUS	Alarms	0 : OK 1 : Failed	OK	d4	Output
337	RO	Thermistor State	ALARM STATUS	Unallocated	0 : False 1 : True	False	jd	Output
523	RW	Armature Current	CONFIGURE DRIVE	Calibration	2.0 to 15.0 AMPS	2.0 Amps	oj	3
18	RO	Autotune	CONFIGURE DRIVE	Current Loop	0 : Off 1 : On	Off	ai	Output, 1
39	RW	Configure Enable	CONFIGURE DRIVE	Unallocated	0 : Disabled 1 : Enabled	Disabled	b3	2
15	RW	CUR.LIMIT/SCALER	CONFIGURE DRIVE	Current Loop	0.00 to 200.00 %	90.00%	af	
24	RW	Encoder Lines	CONFIGURE DRIVE	Calibration	10 to 5000	1024	ao	2
22	RW	Encoder RPM	CONFIGURE DRIVE	Calibration	0 to 6000 RPM	1750 RPM	am	
49	RW	ENCODER SIGN	CONFIGURE DRIVE	Speed Loop	0 : Negative 1 : Positive	Positive	bd	2
524	RW	Field Current	CONFIGURE DRIVE	Calibration	0.2 to 4.0 AMPS	0.2 Amps	ok	3
209	RW	FLD.CTRL MODE	CONFIGURE DRIVE	Field Control	0 : Voltage Control 1 : Current Control	Voltage Control	ft	2
210	RW	FLD.VOLTS RATIO	CONFIGURE DRIVE	Field Control	0.00 to 100.00 % (h)	67.0%	fu	
521	RW	NOM Motor Volts	CONFIGURE DRIVE	Calibration	100 to 875 Volts	500 Volts	oh	3
13	RW	SPD.INT.TIME	CONFIGURE DRIVE	Speed Loop	0.001 to 30.000 Secs	0.500 Secs	ad	
14	RW	SPD.PROP.GAIN	CONFIGURE DRIVE	Speed Loop	0.00 to 200.00	10	ae	
47	RW	SPEED FBK SELECT	CONFIGURE DRIVE	Speed Loop	0 : Arm Volts Fbk 1 : Analog Tach 2 : Encoder 3 : Encoder/Analog	Arm Volts Fbk	bb 2	
543	RW	Zero CAL Inputs	CONFIGURE DRIVE		Up To Action Requested		p3	1, 2, 3, 4
61	RO	ACTUAL NEG I LIM	DIAGNOSTICS	Diagnostics	xxx.xx % (h)	-90.0%	bp	Output
67	RO	ACTUAL POS I LIM	DIAGNOSTICS	Diagnostics	xxx.xx % (h)	90.00%	bv	Output
50	RO	ANIN 1 (A2)	DIAGNOSTICS	Analog Input 1	xxx.xx VOLTS	0.00V	be	Output
51	RO	ANIN 2 (A3)	DIAGNOSTICS	Analog Input 2	xxx.xx VOLTS	0.00V	bf	Output
52	RO	ANIN 3 (A4)	DIAGNOSTICS	Analog Input 3	xxx.xx VOLTS	0.00V	bg	Output
53	RO	ANIN 4 (A5)	DIAGNOSTICS	Analog Input 4	xxx.xx VOLTS	0.00V	bh	Output
54	RO	ANIN 5 (A6)	DIAGNOSTICS	Analog Input 5	xxx.xx VOLTS	10.00V	bi	Output
55	RO	ANOUT 1 (A7)	DIAGNOSTICS	Analog Output 1	xxx.xx VOLTS (h)	0.00V	bj	Output
56	RO	ANOUT 2 (A8)	DIAGNOSTICS	Analog Output 2	xxx.xx VOLTS (h)	0.00V	bk	Output
605	RO	ARM Volts FBK	DIAGNOSTICS	Unallocated		0 Volts		Output

Table B-3 Parameters Listed by Keypad Menu Continued

Tag	R/W	Name	Keypad Menu	WB Block	Range	Factory Setting	MN	Notes
42	RO	At Current Limit	DIAGNOSTICS	Current Loop	0 : False 1 : True	False	b6	Output
79	RO	At Standstill	DIAGNOSTICS	Standstill	0 : False 1 : True	True	c7	Output
78	RO	At Zero Setpoint	DIAGNOSTICS	Standstill	0 : False 1 : True	True	c6	Output
77	RO	At Zero Speed	DIAGNOSTICS	Standstill	0 : False 1 : True	True	c5	Output
60	RO	BACK EMF	DIAGNOSTICS	Calibration	xxx.xx % (h)	0.0%	bo	Output
525	RO	Coast Stop	DIAGNOSTICS	Stop Rates	0 : False 1 : True	FALSE	ol	Output
83	RO	Contactora Closed	DIAGNOSTICS	Unallocated	0 : Off 1 : On	Off	cb	Output
299	RO	Current Demand	DIAGNOSTICS	Diagnostics	xxx.xx %	0.00%	ib	Output
538	RO	Current FBK.Amps	DIAGNOSTICS	Current Loop	xxxx.x AMPS	0.0 Amps	oy	Output, 1, 3
298	RO	Current Feedback	DIAGNOSTICS	Diagnostics	xxx.xx %	0.00%	ia	Output
71	RO	DIGIN 1 (C6)	DIAGNOSTICS	Digital Input 1	0 : Off 1 : On	Off	bz	Output
72	RO	DIGIN 2 (C7)	DIAGNOSTICS	Digital Input 2	0 : Off 1 : On	Off	c0	Output
73	RO	DIGIN 3 (C8)	DIAGNOSTICS	Digital Input 3	0 : Off 1 : On	Off	c1	Output
69	RO	Digital Input C4	DIAGNOSTICS	Aux I/O	0 : Off 1 : On	Off	bx	Output
70	RO	Digital Input C5	DIAGNOSTICS	Aux I/O	0 : Off 1 : On	On	by	Output
74	RO	DIGOUT 1 (B5)	DIAGNOSTICS	Digout 1 (B5)	0 : Off 1 : On	On	c2	Output
75	RO	DIGOUT 2 (B6)	DIAGNOSTICS	Digout 2 (B6)	0 : Off 1 : On	On	c3	Output
76	RO	DIGOUT 3 (B7)	DIAGNOSTICS	Digout 3 (B7)	0 : Off 1 : On	Off	c4	Output
84	RO	Drive Enable	DIAGNOSTICS	Diagnostics	0 : Disabled 1 : Enabled	Disabled	cc	Output
376	RO	Drive Running	DIAGNOSTICS	Unallocated	0 : False 1 : True	False	kg	Output
82	RO	Drive Start	DIAGNOSTICS	Diagnostics	0 : Off 1 : On	Off	ca	Output
206	RO	Encoder	DIAGNOSTICS	Diagnostics	xxxxx RPM	0 RPM	fq	Output
183	RO	Field Demand	DIAGNOSTICS	Field Control	xxx.xx %	0.00%	f3	Output
169	RO	Field Enabled	DIAGNOSTICS	Field Control	0 : Disabled 1 : Enabled	Disabled	ep	Output
300	RO	FIELD I FBK.	DIAGNOSTICS	Diagnostics	xxx.xx %	0.00%	ic	Output
539	RO	Field I FBK.AMPS	DIAGNOSTICS	Current Loop	xxxx.x AMPS	0.0 Amps	oz	Output, 1, 3
184	RO	FLD.FIRING ANGLE	DIAGNOSTICS	Field Control	xxx.xx DEG	0.00 Deg	f4	Output
122	RO	Health LED	DIAGNOSTICS	Alarms	0 : False 1 : True	True	de	Output
66	RO	IaDmd UNFILTERED	DIAGNOSTICS	Current Loop	xxx.xx % (h)	0.0%	bu	Output
65	RO	IaFbk UNFILTERED	DIAGNOSTICS	Current Loop	xxx.xx % (h)	0.0%	bt	Output
203	RO	Inverse Time O/P	DIAGNOSTICS	Inverse Time	xxx.xx %	200.0%	fn	Output, 2, 4
88	RO	NEG. I CLAMP	DIAGNOSTICS	Diagnostics	xxx.xx % (h)	-90.0%	cg	Output
212	RO	Operating Mode	DIAGNOSTICS	Jog/Slack	0 : Stop 1 : Stop 2 : Jog Sp. 1 3 : Jog Sp. 2 4 : Run 5 : Take Up Sp. 1 6 : Take Up Sp. 2 7 : Crawl	Stop	fw	Output
416	RO	PID Clamped	DIAGNOSTICS	PID	0 : False 1 : True	False	lk	Output
415	RO	PID Error	DIAGNOSTICS	PID	xxx.xx %	0.00%	lj	Output
417	RO	PID Output	DIAGNOSTICS	PID	xxx.xx %	0.00%	ll	Output
87	RO	POS. I CLAMP	DIAGNOSTICS	Diagnostics	xxx.xx % (h)	90.0%	cf	Output
80	RO	Program Stop	DIAGNOSTICS	Stop Rates	0 : False 1 : True	False	c8	Output
264	RO	Raise/Lower O/P	DIAGNOSTICS	Raise/Lower	xxx.xx %	0.00%	hc	Output
85	RO	Ramp Output	DIAGNOSTICS	Ramps	xxx.xx %	0.00%	cd	Output
113	RO	Ramping	DIAGNOSTICS	Ramps	0 : False 1 : True	False	d5	Output
125	RO	Ready	DIAGNOSTICS	Alarms	0 : False 1 : True	False	dh	Output
89	RO	Speed Demand	DIAGNOSTICS	Stop Rates	xxx.xx %	0.00%	ch	Output
297	RO	Speed Error	DIAGNOSTICS	Diagnostics	xxx.xx %	-0.01%	i9	Output
207	RO	Speed Feedback	DIAGNOSTICS	Diagnostics	xxx.xx %	0.01%	fr	Output
549	RO	Speed LOOP O/P	DIAGNOSTICS	Speed Loop	-200 to 200 %	0.00%	p9	Output, 2
63	RO	Speed Setpoint	DIAGNOSTICS	Speed Loop	xxx.xx %	0.00%	br	Output
86	RO	SPT SUM OUTPUT	DIAGNOSTICS	Setpoint Sum 1	xxx.xx %	0.00%	ce	Output
68	RO	Start (C3)	DIAGNOSTICS	Aux I/O	0 : Off 1 : On	Off	bw	Output
374	RO	System Reset	DIAGNOSTICS	Unallocated	0 : False 1 : True	True	ke	Output
308	RO	Tach Input	DIAGNOSTICS	Diagnostics	xxx.xx % (h)	0.0%	ik	Output
57	RO	Terminal Volts	DIAGNOSTICS	Calibration	xxx.xx % (h)	0.0%	bl	Output
181	RO	Unfil. Field FBK	DIAGNOSTICS	Calibration	xxx.xx %	0.00%	f1	Output

Table B-3 Parameters Listed by Keypad Menu Continued

Tag	R/W	Name	Keypad Menu	WB Block	Range	Factory Setting	MN	Notes
59	RO	UNFIL.ENCODER	DIAGNOSTICS	Calibration	xxxxx RPM	0 RPM	bn	Output
64	RO	UNFIL.SPD.ERROR	DIAGNOSTICS	Speed Loop	xxx.xx %	0.00%	bs	Output
62	RO	UNFIL.SPD.FBK	DIAGNOSTICS	Speed Loop	xxx.xx %	0.03%	bq	Output
58	RO	UNFIL.TACH INPUT	DIAGNOSTICS	Calibration	xxx.xx % (h)	0.0%	bm	Output
37	RW	FULL MENUS	MENUS	Menus	0 : Disabled 1 : Enabled	Enabled	b1	
354	RW	Parameter Save	PARAMETER SAVE	Unallocated	Up To Action Requested		ju	1
121	RW	Change Password	PASSWORD		0x0000 to 0xFFFF	0x0000	dd	
120	RW	Enter Password	PASSWORD		0x0000 to 0xFFFF	0x0000	dc	1
155	RO	Version Number	SERIAL LINKS::SYSTEM PORT (P3)	Unallocated	0x0000 to 0xFFFF		eb	Output
130	RW	Mode	SERIAL LINKS::SYSTEM PORT (P3)::P3 SET-UP	System Port P3	0 : Disabled 1 : 5703 Master 2 : 5703 Slave 3 : CELite (EIASCII)	0	dm	
198	RW	P3 Baud Rate	SERIAL LINKS::SYSTEM PORT (P3)::P3 SET-UP		0:300 1:600 2:1200 3:2400 4:4800 5:9600 6:19200	9600	fi	2
187	RO	Raw Input	SERIAL LINKS::SYSTEM PORT (P3)::P3 SET-UP::5703 SUPPORT	5703	xxx.xx %	0.00%	f7	Output
189	RO	Scaled Input	SERIAL LINKS::SYSTEM PORT (P3)::P3 SET-UP::5703 SUPPORT	5703	xxx.xx %	0.00%	f9	Output, 2
132	RW	SETPT. RATIO	SERIAL LINKS::SYSTEM PORT (P3)::P3 SET-UP::5703 SUPPORT	5703	-3.0000 to 3.0000	0.0000	do	
133	RW	SETPT. SIGN	SERIAL LINKS::SYSTEM PORT (P3)::P3 SET-UP::5703 SUPPORT	5703	0 : Negative 1 : Positive	Positive	dp	
332	RW	Error Report	SERIAL LINKS::SYSTEM PORT (P3)::P3 SET-UP::BISYNCH SUPPORT	System Port P3	0x0000 to 0xFFFF	0x00C0	j8	1
329	RW	GROUP ID (GID)	SERIAL LINKS::SYSTEM PORT (P3)::P3 SET-UP::BISYNCH SUPPORT	System Port P3	0x0000 to 0x0007	0x0000	j5	
330	RW	UNIT ID (UID)	SERIAL LINKS::SYSTEM PORT (P3)::P3 SET-UP::BISYNCH SUPPORT	System Port P3	0x0000 to 0x000F	0x0000	j6	
506	RO	TEC Option Fault	SERIAL LINKS::TEC OPTION	Tec Option	0 : None 1 : Parameter 2 : Type Mismatch 3 : Self Test 4 : Hardware 5 : Missing	None	o2	Output
501	RW	TEC Option IN 1	SERIAL LINKS::TEC OPTION	Tec Option	-32768 to 32767	0	nx	
502	RW	TEC Option IN 2	SERIAL LINKS::TEC OPTION	Tec Option	-32768 to 32767	0	ny	
503	RW	TEC Option IN 3	SERIAL LINKS::TEC OPTION	Tec Option	-32768 to 32767	0	nz	
504	RW	TEC Option IN 4	SERIAL LINKS::TEC OPTION	Tec Option	-32768 to 32767	0	o0	
505	RW	TEC Option IN 5	SERIAL LINKS::TEC OPTION	Tec Option	-32768 to 32767	0	o1	
508	RO	TEC Option OUT 1	SERIAL LINKS::TEC OPTION	Tec Option	xxxxx	0	o4	Output, 1
509	RO	TEC Option OUT 2	SERIAL LINKS::TEC OPTION	Tec Option	xxxxx	0	o5	Output, 1
500	RW	TEC Option Type	SERIAL LINKS::TEC OPTION	Tec Option	0 : None 1 : Rs485 2 : Profibus Dp 3 : Link 4 : Device Net 5 : Can Open 6 : Lonworks 7 : Type 7	None	nw	
507	RO	TEC Option VER	SERIAL LINKS::TEC OPTION	Tec Option	0x0000 to 0xFFFF	0x0000	o3	Output, 1
128	RW	ANOUT 1	SETUP PARAMETERS::AUX I/O	Aux I/O	-100.00 to 100.00 %	0.00%	dk	
129	RW	ANOUT 2	SETUP PARAMETERS::AUX I/O	Aux I/O	-100.00 to 100.00 %	0.00%	dl	
94	RW	AUX DIGOUT 1	SETUP PARAMETERS::AUX I/O	Aux I/O	0 : Off 1 : On	Off	cm	
95	RW	AUX DIGOUT 2	SETUP PARAMETERS::AUX I/O	Aux I/O	0 : Off 1 : On	Off	cn	
96	RW	AUX DIGOUT 3	SETUP PARAMETERS::AUX I/O	Aux I/O	0 : Off 1 : On	Off	co	
168	RW	Aux Enable	SETUP PARAMETERS::AUX I/O	Aux I/O	0 : Off 1 : On	On	eo	

Table B-3 Parameters Listed by Keypad Menu Continued

Tag	R/W	Name	Keypad Menu	WB Block	Range	Factory Setting	MN	Notes
227	RW	AUX JOG	SETUP PARAMETERS::AUX I/O	Aux I/O	0 : Off 1 : On	On	gb	
161	RW	AUX START	SETUP PARAMETERS::AUX I/O	Aux I/O	0 : Off 1 : On	On	eh	
497	RO	Enable	SETUP PARAMETERS::AUX I/O	Aux I/O	0 : Off 1 : On	On	nt	Output
496	RO	Jog/Slack	SETUP PARAMETERS::AUX I/O	Aux I/O	0 : Off 1 : On	Off	ns	Output
535	RW	REM.SEQ.ENABLE	SETUP PARAMETERS::AUX I/O	Aux I/O	0 : False, 1 : True	FALSE	ov	2
536	RW	REM.SEQUENCE	SETUP PARAMETERS::AUX I/O	Aux I/O	0x0000 to 0xFFFF	0x0000	ow	1
537	RO	SEQ Status	SETUP PARAMETERS::AUX I/O	Aux I/O	0x0000 to 0xFFFF	0x0C03	ox	Output
23	RW	Analog TACH CAL	SETUP PARAMETERS::CALIBRATION	Calibration	0.9800 to 1.1000	1.0000	an	
25	RW	Armature I (A9)	SETUP PARAMETERS::CALIBRATION	Calibration	0 : UNIPOLAR 1 : BIPOLAR	Bipolar	ap	
20	RW	Armature V CAL.	SETUP PARAMETERS::CALIBRATION	Calibration	0.9800 to 1.1000	1.0000	ak	
182	RW	Field I CAL.	SETUP PARAMETERS::CALIBRATION	Calibration	0.9800 to 1.1000	1.0000	f2	
21	RW	IR Compensation	SETUP PARAMETERS::CALIBRATION	Calibration	0.00 to 100.00 %	0.00%	al	
188	RW	Over Speed Level	SETUP PARAMETERS::CALIBRATION	Calibration	0.00 to 200.00 %	125.00%	f8	4
541	RW	REM Trip Delay	SETUP PARAMETERS::CALIBRATION	Alarms	0.1 to 600.0 Secs	10.0 Secs	p1	
180	RW	SPDFBK ALM LEVEL	SETUP PARAMETERS::CALIBRATION	Calibration	0.00 to 100.00 % (h)	50.00%	f0	
263	RW	Stall Threshold	SETUP PARAMETERS::CALIBRATION	Calibration	0.00 to 200.00 %	95.00%	hb	
224	RW	Stall Trip Delay	SETUP PARAMETERS::CALIBRATION	Calibration	0.1 to 600.0 Secs	10.0 Secs	g8	
10	RW	Zero SPD. Offset	SETUP PARAMETERS::CALIBRATION	Calibration	-5.00 to 5.00 %	0.00%	aa	
30	RW	Additional DEM	SETUP PARAMETERS::CURRENT LOOP	Current Loop	-200.00 to 200.00 %	0.00%	au	
90	RW	Bipolar Clamps	SETUP PARAMETERS::CURRENT LOOP	Current Loop	0 : Disabled 1 : Enabled	Disabled	ci	
137	RW	Discontinuous	SETUP PARAMETERS::CURRENT LOOP	Current Loop	0.00 to 200.00 %	12.00%	dt	
136	RW	Feed Forward	SETUP PARAMETERS::CURRENT LOOP	Current Loop	0.10 to 50.00	2.00	ds	4
119	RW	I DM.D. ISOLATE	SETUP PARAMETERS::CURRENT LOOP	Current Loop	0 : Disabled 1 : Enabled	Disabled	db	
17	RW	INT. GAIN	SETUP PARAMETERS::CURRENT LOOP	Current Loop	0.00 to 200.00	3.50	ah	
421	RW	MAIN CURR. LIMIT	SETUP PARAMETERS::CURRENT LOOP	Current Loop	0.00 to 200.00 %	200.00%	lp	
527	RO	Master Bridge	SETUP PARAMETERS::CURRENT LOOP	Current Loop	0 : Off 1 : On	Off	on	Output, 1
48	RW	NEG. I CLAMP	SETUP PARAMETERS::CURRENT LOOP	Current Loop	-100.00 to 100.00 %	0.00%	bc	
301	RW	POS. I CLAMP	SETUP PARAMETERS::CURRENT LOOP	Current Loop	-100.00 to 100.00 %	100.00%	id	
16	RW	PROP. GAIN	SETUP PARAMETERS::CURRENT LOOP	Current Loop	0.00 to 200.00	45.00	ag	
201	RW	Regen Mode	SETUP PARAMETERS::CURRENT LOOP	Current Loop	0 : 2Q (Non-regen) 1 : 4Q (Regen)	2Q(Non-regen)	fi	2
93	RW	IMAX BRK1(SPD1)	SETUP PARAMETERS::CURRENT PROFILE	Current Profile	0.00 to 200.00 % (h)	200.00%	cl	2
33	RW	IMAX BRK2(SPD2)	SETUP PARAMETERS::CURRENT PROFILE	Current Profile	0.00 to 200.00 % (h)	200.00%	ax	2
32	RW	SPD BRK1 (LOW)	SETUP PARAMETERS::CURRENT PROFILE	Current Profile	0.00 to 100.00 % (h)	100.00%	aw	2
31	RW	SPD BRK2 (HIGH)	SETUP PARAMETERS::CURRENT PROFILE	Current Profile	0.00 to 100.00 % (h)	100.00%	av	2
170	RW	Field Enable	SETUP PARAMETERS::FIELD CONTROL	Field Control	0 : Disabled 1 : Enabled	Enabled	eq	2
617	RW	Field I Thresh	SETUP PARAMETERS::FIELD CONTROL	Field Control	0.00 to 100.00 %	80.00%		
186	RW	FLD. QUENCH MODE	SETUP PARAMETERS::FIELD CONTROL	Field Control	0 : Quench 1 : Standby	Quench	f6	
185	RW	FLD.QUENCH DELAY	SETUP PARAMETERS::FIELD CONTROL	Field Control	0.0 to 600.0 Secs	0.0 Secs	f5	
618	RO	Up To Field	SETUP PARAMETERS::FIELD CONTROL	Field Control	0 : False 1 : True	False		Output
172	RW	INT. GAIN	SETUP PARAMETERS::FIELD CONTROL::FLD.CURRENT VARS	Field Control	0.00 to 100.00	1.28	es	
173	RW	PROP. GAIN	SETUP PARAMETERS::FIELD CONTROL::FLD.CURRENT VARS	Field Control	0.00 to 100.00	0.10	et	
171	RW	Setpoint	SETUP PARAMETERS::FIELD CONTROL::FLD.CURRENT VARS	Field Control	0.00 to 100.00 %	100.00%	er	
192	RW	BEMF FBK LAG	SETUP PARAMETERS::FIELD CONTROL::FLD.CURRENT VARS::FLD.WEAK VARS	Field Control	10 to 5000	100	fc	
191	RW	BEMF FBK LEAD	SETUP PARAMETERS::FIELD CONTROL::FLD.CURRENT VARS::FLD.WEAK VARS	Field Control	10 to 5000	100	fb	
177	RW	EMF GAIN	SETUP PARAMETERS::FIELD CONTROL::FLD.CURRENT VARS::FLD.WEAK VARS	Field Control	0.00 to 100.00	0.30	ex	
176	RW	EMF LAG	SETUP PARAMETERS::FIELD CONTROL::FLD.CURRENT VARS::FLD.WEAK VARS	Field Control	0.00 to 200.00	40.00	ew	
175	RW	EMF LEAD	SETUP PARAMETERS::FIELD CONTROL::FLD.CURRENT VARS::FLD.WEAK VARS	Field Control	0.10 to 50.00	2.00	ev	
174	RW	FLD. WEAK ENABLE	SETUP PARAMETERS::FIELD CONTROL::FLD.CURRENT VARS::FLD.WEAK VARS	Field Control	0 : Disabled 1 : Enabled	Disabled	eu	2

Table B-3 Parameters Listed by Keypad Menu Continued

Tag	R/W	Name	Keypad Menu	WB Block	Range	Factory Setting	MN	Notes
178	RW	MAX VOLTS	SETUP PARAMETERS::FIELD CONTROL::FLD.CURRENT VARS::FLD.WEAK VARS	Field Control	0.00 to 100.00 %	100.00%	ey	
179	RW	MIN FLD.CURRENT	SETUP PARAMETERS::FIELD CONTROL::FLD.CURRENT VARS::FLD.WEAK VARS	Field Control	0.00 to 100.00 %	10.00%	ez	2
111	RW	5703 RCV ERROR	SETUP PARAMETERS::INHIBIT ALARMS	Alarms	0 : Enabled 1 : Inhibited	Enabled	d3	
92	RW	Encoder Alarm	SETUP PARAMETERS::INHIBIT ALARMS	Alarms	0 : Enabled 1 : Inhibited	Enabled	ck	
19	RW	Field Fail	SETUP PARAMETERS::INHIBIT ALARMS	Alarms	0 : Enabled 1 : Inhibited	Enabled	aj	
540	RW	REM Trip Inhibit	SETUP PARAMETERS::INHIBIT ALARMS	Alarms	0 : Enabled 1 : Inhibited	Enabled	p0	
81	RW	SPEED FBK ALARM	SETUP PARAMETERS::INHIBIT ALARMS	Alarms	0 : Enabled 1 : Inhibited	Enabled	c9	
28	RW	Stall Trip	SETUP PARAMETERS::INHIBIT ALARMS	Alarms	0 : Enabled 1 : Inhibited	Inhibited	as	
305	RW	Trip Reset	SETUP PARAMETERS::INHIBIT ALARMS	Alarms	0 : False 1 : True	TRUE	ih	
204	RW	Aiming Point	SETUP PARAMETERS::INVERSE TIME	Inverse Time	0.00 to 103.00 %	103.00%	fo	2, 4
199	RW	Delay	SETUP PARAMETERS::INVERSE TIME	Inverse Time	0.1 to 600.0 Secs	10.0 Secs	fj	2, 4
200	RW	Rate	SETUP PARAMETERS::INVERSE TIME	Inverse Time	0.1 to 600.0 Secs	60.0 Secs	fk	2, 4
225	RW	Crawl Speed	SETUP PARAMETERS::JOG/SLACK	Jog/Slack	-100.00 to 100.00 %	10.00%	g9	
218	RW	Jog Speed 1	SETUP PARAMETERS::JOG/SLACK	Jog/Slack	-100.00 to 100.00 %	20.00 %	g2	
219	RW	Jog Speed 2	SETUP PARAMETERS::JOG/SLACK	Jog/Slack	-100.00 to 100.00 %	-5.00 %	g3	
228	RW	Mode	SETUP PARAMETERS::JOG/SLACK	Jog/Slack	0 : False 1 : True	FALSE	gc	
355	RW	Ramp Rate	SETUP PARAMETERS::JOG/SLACK	Jog/Slack	0.1 to 600.0 Secs	1.0 Secs	ju	
253	RW	Take Up 1	SETUP PARAMETERS::JOG/SLACK	Jog/Slack	-100.00 to 100.00 %	5.00%	h1	
254	RW	Take Up 2	SETUP PARAMETERS::JOG/SLACK	Jog/Slack	-100.00 to 100.00 %	-5.00%	h2	
514	RW	Ramp Accel Time	SETUP PARAMETERS::OP STATION::LOCAL RAMP	Op Station	0.1 to 600.0 Secs	10.0 Secs	oa	
515	RW	Ramp Decel Time	SETUP PARAMETERS::OP STATION::LOCAL RAMP	Op Station	0.1 to 600.0 Secs	10.0 Secs	ob	
513	RW	Jog Setpoint	SETUP PARAMETERS::OP STATION::SET UP	Op Station	0.00 to 100.00 %	5.00%	o9	1
511	RW	Local Key Enable	SETUP PARAMETERS::OP STATION::SET UP	Op Station	0 : False 1 : True	TRUE	o7	
512	RW	Setpoint	SETUP PARAMETERS::OP STATION::SET UP	Op Station	0.00 to 100.00 %	0.00%	o8	1
516	RW	Forward	SETUP PARAMETERS::OP STATION::START UP VALUES	Op Station	0 : False 1 : True	TRUE	oc	
520	RW	Jog Setpoint	SETUP PARAMETERS::OP STATION::START UP VALUES	Op Station	0.00 to 100.00 %	5.00%	og	
517	RW	Local	SETUP PARAMETERS::OP STATION::START UP VALUES	Op Station	0 : False 1 : True	TRUE	od	
518	RW	Program	SETUP PARAMETERS::OP STATION::START UP VALUES	Op Station	0 : False 1 : True	FALSE	oe	
519	RW	Setpoint	SETUP PARAMETERS::OP STATION::START UP VALUES	Op Station	0.00 to 100.00 %	0.00%	of	
257	RW	Decrease Rate	SETUP PARAMETERS::RAISE/LOWER	Raise/Lower	0.1 to 600.0 Secs	10.0 Secs	h5	
307	RW	External Reset	SETUP PARAMETERS::RAISE/LOWER	Raise/Lower	0 : False 1 : True	FALSE	ij	
256	RW	Increase Rate	SETUP PARAMETERS::RAISE/LOWER	Raise/Lower	0.1 to 600.0 Secs	10.0 Secs	h4	
262	RW	Lower Input	SETUP PARAMETERS::RAISE/LOWER	Raise/Lower	0 : False 1 : True	FALSE	ha	
259	RW	Max Value	SETUP PARAMETERS::RAISE/LOWER	Raise/Lower	-300.00 to 300.00 %	100.00%	h7	
258	RW	Min Value	SETUP PARAMETERS::RAISE/LOWER	Raise/Lower	-300.00 to 300.00 %	-100.00%	h6	
261	RW	Raise Input	SETUP PARAMETERS::RAISE/LOWER	Raise/Lower	0 : False 1 : True	FALSE	h9	
255	RW	Reset Value	SETUP PARAMETERS::RAISE/LOWER	Raise/Lower	-300.00 to 300.00 %	0.00%	h3	
266	RW	% S-RAMP	SETUP PARAMETERS::RAMPS	Ramps	0.00 to 100.00 %	2.50%	he	
287	RW	Auto Reset	SETUP PARAMETERS::RAMPS	Ramps	0 : Disabled 1 : Enabled	Enabled	hz	
4	RW	Constant Accel	SETUP PARAMETERS::RAMPS	Ramps	0 : Disabled 1 : Enabled	Enabled	a4	
288	RW	External Reset	SETUP PARAMETERS::RAMPS	Ramps	0 : Disabled 1 : Enabled	Disabled	i0	
620	RW	Invert	SETUP PARAMETERS::RAMPS	Ramps	0 : False 1 : True	False		
126	RW	MIN SPEED	SETUP PARAMETERS::RAMPS	Ramps	0.00 to 100.00 %	0.00%	di	
2	RW	Ramp Accel Time	SETUP PARAMETERS::RAMPS	Ramps	0.1 to 600.0 Secs	10.0 Secs	a2	
3	RW	Ramp Decel Time	SETUP PARAMETERS::RAMPS	Ramps	0.1 to 600.0 Secs	10.0 Secs	a3	
118	RW	Ramp Hold	SETUP PARAMETERS::RAMPS	Ramps	0 : Off 1 : On	Off	da	
5	RW	Ramp Input	SETUP PARAMETERS::RAMPS	Ramps	-105.00 to 105.00 %	0.00%	a5	
286	RW	RAMPING THRESH.	SETUP PARAMETERS::RAMPS	Ramps	0.00 to 100.00 %	0.50%	hy	
422	RW	Reset Value	SETUP PARAMETERS::RAMPS	Ramps	-300.00 to 300.00 %	0.00%	lq	
131	RW	Deadband Width	SETUP PARAMETERS::SETPOINT SUM 1	Setpoint Sum 1	0.00 to 100.00 % (h)	0.0%	dn	
420	RW	Divider 0	SETUP PARAMETERS::SETPOINT SUM 1	Setpoint Sum 1	-3.0000 to 3.0000	1.0000	lo	
419	RW	Divider 1	SETUP PARAMETERS::SETPOINT SUM 1	Setpoint Sum 1	-3.0000 to 3.0000	1.0000	ln	

Table B-3 Parameters Listed by Keypad Menu Continued

Tag	R/W	Name	Keypad Menu	WB Block	Range	Factory Setting	MN	Notes
309	RW	Input 0	SETUP PARAMETERS::SETPOINT SUM 1	Setpoint Sum 1	-200.00 to 200.00 %	0.00%	il	
100	RW	Input 1	SETUP PARAMETERS::SETPOINT SUM 1	Setpoint Sum 1	-200.00 to 200.00 %	0.00%	cs	
423	RW	Input 2	SETUP PARAMETERS::SETPOINT SUM 1	Setpoint Sum 1	-200.00 to 200.00 %	0.00%	lr	
375	RW	Limit	SETUP PARAMETERS::SETPOINT SUM 1	Setpoint Sum 1	0.00 to 200.00 %	105.00%	kf	
208	RW	Ratio 0	SETUP PARAMETERS::SETPOINT SUM 1	Setpoint Sum 1	-3.0000 to 3.0000	1.0000	fs	
6	RW	Ratio 1	SETUP PARAMETERS::SETPOINT SUM 1	Setpoint Sum 1	-3.0000 to 3.0000	1.0000	a6	
292	RW	SIGN 0	SETUP PARAMETERS::SETPOINT SUM 1	Setpoint Sum 1	0 : Negative 1 : Positive	Positive	i4	
8	RW	Sign 1	SETUP PARAMETERS::SETPOINT SUM 1	Setpoint Sum 1	0 : Negative 1 : Positive	Positive	a8	
401	RW	DERIVATIVE TC	SETUP PARAMETERS::SPECIAL BLOCKS::PID	PID	0.000 to 10.000 Secs	0.000Secs	l5	
418	RW	Divider 1	SETUP PARAMETERS::SPECIAL BLOCKS::PID	PID	-3.0000 to 3.0000	1.0000	lm	
414	RW	Divider 2	SETUP PARAMETERS::SPECIAL BLOCKS::PID	PID	-3.0000 to 3.0000	1.0000	li	
408	RW	Enable	SETUP PARAMETERS::SPECIAL BLOCKS::PID	PID	0 : Disabled 1 : Enabled	Enabled	lc	
403	RW	FILTER T.C.	SETUP PARAMETERS::SPECIAL BLOCKS::PID	PID	0.000 to 10.000 Secs	0.100 Secs	l7	
410	RW	Input 1	SETUP PARAMETERS::SPECIAL BLOCKS::PID	PID	-300.00 to 300.00 %	0.00%	le	
411	RW	Input 2	SETUP PARAMETERS::SPECIAL BLOCKS::PID	PID	-300.00 to 300.00 %	0.00%	lf	
409	RW	INT. DEFEAT	SETUP PARAMETERS::SPECIAL BLOCKS::PID	PID	0 : Off 1 : On	Off	ld	
402	RW	INT.TIME.CONST	SETUP PARAMETERS::SPECIAL BLOCKS::PID	PID	0.01 to 100.00 Secs	5.00 Secs	l6	
474	RW	MIN PROFILE GAIN	SETUP PARAMETERS::SPECIAL BLOCKS::PID	PID	0.00 to 100.00 %	20.00%	n6	
473	RW	Mode	SETUP PARAMETERS::SPECIAL BLOCKS::PID	PID	0 to 4	0	n5	
406	RW	Negative Limit	SETUP PARAMETERS::SPECIAL BLOCKS::PID	PID	-105.00 to 0.00 %	-100.00%	la	
407	RW	O/P SCALER(TRIM)	SETUP PARAMETERS::SPECIAL BLOCKS::PID	PID	-3.0000 to 3.0000	0.2000	lb	
405	RW	Positive Limit	SETUP PARAMETERS::SPECIAL BLOCKS::PID	PID	0.00 to 105.00 %	100.00%	l9	
475	RO	Profiled Gain	SETUP PARAMETERS::SPECIAL BLOCKS::PID	PID	xxxx.x	0.0	n7	Output
404	RW	PROP. GAIN	SETUP PARAMETERS::SPECIAL BLOCKS::PID	PID	0.0 to 100.0	1.0	l8	
412	RW	Ratio 1	SETUP PARAMETERS::SPECIAL BLOCKS::PID	PID	-3.0000 to 3.0000	1.0000	lg	
413	RW	Ratio 2	SETUP PARAMETERS::SPECIAL BLOCKS::PID	PID	-3.0000 to 3.0000	1.0000	lh	
202	RW	INT. DEFEAT	SETUP PARAMETERS::SPEED LOOP	Speed Loop	0 : Off 1 : On	Off	fm	
547	RW	SPD.FBK.FILTER	SETUP PARAMETERS::SPEED LOOP	Menus	0.000 to 1.000	0.000	p7	
274	RW	I GAIN IN RAMP	SETUP PARAMETERS::SPEED LOOP::ADVANCED	Advanced	0.0000 to 2.0000	1.0000	hm	
273	RW	POS. LOOP P GAIN	SETUP PARAMETERS::SPEED LOOP::ADVANCED	Advanced	-200.00 to 200.00 %	0.00%	hl	4
268	RW	Mode	SETUP PARAMETERS::SPEED LOOP::ADVANCED::ADAPTION	Advanced	0 to 3	0	hg	
271	RW	PROP. GAIN	SETUP PARAMETERS::SPEED LOOP::ADVANCED::ADAPTION	Advanced	0.00 to 200.00	5.00	hj	
269	RW	SPD BRK1 (LOW)	SETUP PARAMETERS::SPEED LOOP::ADVANCED::ADAPTION	Advanced	0.00 to 100.00 %	1.00%	hh	
270	RW	SPD BRK2 (HIGH)	SETUP PARAMETERS::SPEED LOOP::ADVANCED::ADAPTION	Advanced	0.00 to 100.00 %	5.00%	hi	
272	RW	SPD.INT.TIME	SETUP PARAMETERS::SPEED LOOP::ADVANCED::ADAPTION	Advanced	0.001 to 30.000 Secs	0.500 Secs	hk	
285	RW	ZERO IAD LEVEL	SETUP PARAMETERS::SPEED LOOP::ADVANCED::ZERO SPD. QUENCH	Advanced	0.00 to 200.00 %	1.50%	hx	
284	RW	ZERO SPD. LEVEL	SETUP PARAMETERS::SPEED LOOP::ADVANCED::ZERO SPD. QUENCH	Advanced	0.00 to 200.00 %	0.50%	hw	
357	RW	Max Demand	SETUP PARAMETERS::SPEED LOOP::SETPOINTS	Speed Loop	0.00 to 105.00 %	105.00%	jx	
358	RW	Min Demand	SETUP PARAMETERS::SPEED LOOP::SETPOINTS	Speed Loop	-105.00 to 105.00 %	-105.00%	jy	
7	RW	Ratio 2 (A3)	SETUP PARAMETERS::SPEED LOOP::SETPOINTS	Speed Loop	-3.0000 to 3.0000	.0000	a7	
289	RW	Setpoint 1	SETUP PARAMETERS::SPEED LOOP::SETPOINTS	Speed Loop	-105.00 to 105.00 %	0.00%	i1	
290	RO	Setpoint 2 (A3)	SETUP PARAMETERS::SPEED LOOP::SETPOINTS	Speed Loop	xxx.xx %	0.00%	i2	Output
291	RW	Setpoint 3	SETUP PARAMETERS::SPEED LOOP::SETPOINTS	Speed Loop	-105.00 to 105.00 %	0.00%	i3	
41	RW	Setpoint 4	SETUP PARAMETERS::SPEED LOOP::SETPOINTS	Speed Loop	-105.00 to 105.00 %	0.00%	b5	
9	RW	Sign 2 (A3)	SETUP PARAMETERS::SPEED LOOP::SETPOINTS	Speed Loop	0 : Negative 1 : Positive	Positive	a9	

Table B-3 Parameters Listed by Keypad Menu Continued

Tag	R/W	Name	Keypad Menu	WB Block	Range	Factory Setting	MN	Notes
306	RW	Source Tag	SETUP PARAMETERS::STANDSTILL	Standstill	0 to 549	89	ii	2, 3, 4
11	RW	Standstill Logic	SETUP PARAMETERS::STANDSTILL	Standstill	0 : Disabled 1 : Enabled	Disabled	ab	
12	RW	Zero Threshold	SETUP PARAMETERS::STANDSTILL	Standstill	0.00 to 100.00 %	2.00%	ac	
302	RW	Contactor Delay	SETUP PARAMETERS::STOP RATES	Stop Rates	0.1 to 600.0 Secs	1.0 Secs	ie	
594	RW	CURR Decay Rate	SETUP PARAMETERS::STOP RATES	Stop Rates	0 to 200.00	0.00		
91	RW	PROG STOP I LIM	SETUP PARAMETERS::STOP RATES	Stop Rates	0.00 to 200.00 %	100.00%	cj	
216	RW	PROG STOP LIMIT	SETUP PARAMETERS::STOP RATES	Stop Rates	0.0 to 600.0 Secs	60.0 Secs	g0	
26	RW	PROG Stop Time	SETUP PARAMETERS::STOP RATES	Stop Rates	0.1 to 600.0 Secs	0.1 Secs	aq	
217	RW	Stop Limit	SETUP PARAMETERS::STOP RATES	Stop Rates	0.0 to 600.0 Secs	60.0 Secs	g1	
27	RW	Stop Time	SETUP PARAMETERS::STOP RATES	Stop Rates	0.1 to 600.0 Secs	10.0 Secs	ar	
29	RW	Stop Zero Speed	SETUP PARAMETERS::STOP RATES	Stop Rates	0.00 to 100.00 %	2.00%	at	
230	RW	Calibration	SYSTEM::CONFIGURE I/O::ANALOG INPUTS::ANIN 1 (A2)	Analog Input 1	-3.0000 to 3.0000	1.0000	ge	
246	RW	Destination Tag	SYSTEM::CONFIGURE I/O::ANALOG INPUTS::ANIN 1 (A2)	Analog Input 1	0 to 549	100	gu	2, 3
231	RW	Max Value	SYSTEM::CONFIGURE I/O::ANALOG INPUTS::ANIN 1 (A2)	Analog Input 1	-300.00 to 300.00 %	100.00%	gf	
232	RW	Min Value	SYSTEM::CONFIGURE I/O::ANALOG INPUTS::ANIN 1 (A2)	Analog Input 1	-300.00 to 300.00 %	-100.00%	gg	
233	RW	Calibration	SYSTEM::CONFIGURE I/O::ANALOG INPUTS::ANIN 2 (A3)	Analog Input 2	-3.0000 to 3.0000	1.0000	gh	
234	RW	Max Value	SYSTEM::CONFIGURE I/O::ANALOG INPUTS::ANIN 2 (A3)	Analog Input 2	-300.00 to 300.00 %	100.00%	gi	
235	RW	Min Value	SYSTEM::CONFIGURE I/O::ANALOG INPUTS::ANIN 2 (A3)	Analog Input 2	-300.00 to 300.00 %	-100.00%	gj	
493	RO	Output	SYSTEM::CONFIGURE I/O::ANALOG INPUTS::ANIN 2 (A3)	Analog Input 2	xxx.xx %	0.00%	np	Output, 2
236	RW	Calibration	SYSTEM::CONFIGURE I/O::ANALOG INPUTS::ANIN 3 (A4)	Analog Input 3	-3.0000 to 3.0000	1.0000	gk	
249	RW	Destination Tag	SYSTEM::CONFIGURE I/O::ANALOG INPUTS::ANIN 3 (A4)	Analog Input 3	0 to 549	5	gx	2, 3
237	RW	Max Value	SYSTEM::CONFIGURE I/O::ANALOG INPUTS::ANIN 3 (A4)	Analog Input 3	-300.00 to 300.00 %	100.00%	gl	
238	RW	Min Value	SYSTEM::CONFIGURE I/O::ANALOG INPUTS::ANIN 3 (A4)	Analog Input 3	-300.00 to 300.00 %	-100.00%	gm	
239	RW	Calibration	SYSTEM::CONFIGURE I/O::ANALOG INPUTS::ANIN 4 (A5)	Analog Input 4	-3.0000 to 3.0000	1.0000	gn	
250	RW	Destination Tag	SYSTEM::CONFIGURE I/O::ANALOG INPUTS::ANIN 4 (A5)	Analog Input 4	0 to 549	48	gy	2, 3
240	RW	Max Value	SYSTEM::CONFIGURE I/O::ANALOG INPUTS::ANIN 4 (A5)	Analog Input 4	-300.00 to 300.00 %	100.00%	go	
241	RW	Min Value	SYSTEM::CONFIGURE I/O::ANALOG INPUTS::ANIN 4 (A5)	Analog Input 4	-300.00 to 300.00 %	-100.00%	gp	
242	RW	Calibration	SYSTEM::CONFIGURE I/O::ANALOG INPUTS::ANIN 5 (A6)	Analog Input 5	-3.0000 to 3.0000	1.0000	gq	
247	RW	Destination Tag	SYSTEM::CONFIGURE I/O::ANALOG INPUTS::ANIN 5 (A6)	Analog Input 5	0 to 549	301	gv	2, 3
243	RW	Max Value	SYSTEM::CONFIGURE I/O::ANALOG INPUTS::ANIN 5 (A6)	Analog Input 5	-300.00 to 300.00 %	200.00%	gr	
244	RW	Min Value	SYSTEM::CONFIGURE I/O::ANALOG INPUTS::ANIN 5 (A6)	Analog Input 5	-300.00 to 300.00 %	-200.00%	gs	
245	RW	% TO GET 10V	SYSTEM::CONFIGURE I/O::ANALOG OUTPUTS::ANOUT 1 (A7)	Analog Output 1	-300.00 to 300.00 %	100.00%	gt	
362	RW	Modulus	SYSTEM::CONFIGURE I/O::ANALOG OUTPUTS::ANOUT 1 (A7)	Analog Output 1	0 : False 1 : True	FALSE	k2	
464	RW	Offset	SYSTEM::CONFIGURE I/O::ANALOG OUTPUTS::ANOUT 1 (A7)	Analog Output 1	-100.00 to 100.00 %	0.00%	mw	
251	RW	Source Tag	SYSTEM::CONFIGURE I/O::ANALOG OUTPUTS::ANOUT 1 (A7)	Analog Output 1	0 to 549	62	gz	2, 3
248	RW	% TO GET 10V	SYSTEM::CONFIGURE I/O::ANALOG OUTPUTS::ANOUT 2 (A8)	Analog Output 2	-300.00 to 300.00 %	100.00%	gw	
363	RW	Modulus	SYSTEM::CONFIGURE I/O::ANALOG OUTPUTS::ANOUT 2 (A8)	Analog Output 2	0 : False 1 : True	FALSE	k3	

Table B-3 Parameters Listed by Keypad Menu Continued

Tag	R/W	Name	Keypad Menu	WB Block	Range	Factory Setting	MN	Notes
465	RW	Offset	SYSTEM::CONFIGURE I/O::ANALOG OUTPUTS::ANOUT 2 (A8)	Analog Output 2	-100.00 to 100.00 %	0.00%	mx	
252	RW	Source Tag	SYSTEM::CONFIGURE I/O::ANALOG OUTPUTS::ANOUT 2 (A8)	Analog Output 2	0 to 549	63	h0	2, 3
400	RW	PID O/P DEST	SYSTEM::CONFIGURE I/O::BLOCK DIAGRAM	PID Output	0 to 549	0	l4	2, 3
260	RW	Raise/Lower Dest	SYSTEM::CONFIGURE I/O::BLOCK DIAGRAM	Raise/Lower Output	0 to 549	0	h8	
293	RW	RAMP O/P DEST	SYSTEM::CONFIGURE I/O::BLOCK DIAGRAM	Ramp Output	0 to 549	291	i5	2, 3
294	RW	SPT SUM 1 DEST	SYSTEM::CONFIGURE I/O::BLOCK DIAGRAM	Setpoint Sum 1 Output	0 to 549	289	i6	2, 3
135	RW	Destination Tag	SYSTEM::CONFIGURE I/O::CONFIGURE 5703	Scaled 5703 Input	0 to 549	41	dr	2, 3
134	RW	Source Tag	SYSTEM::CONFIGURE I/O::CONFIGURE 5703	5703	0 to 549	89	dq	2, 3
102	RW	Destination Tag	SYSTEM::CONFIGURE I/O::DIGITAL INPUTS::DIGIN 1 (C6)	Digital Input 1	0 to 549	90	cu	2, 3
104	RW	Value For False	SYSTEM::CONFIGURE I/O::DIGITAL INPUTS::DIGIN 1 (C6)	Digital Input 1	-300.00 to 300.00 %	0.00%	cw	
103	RW	Value For True	SYSTEM::CONFIGURE I/O::DIGITAL INPUTS::DIGIN 1 (C6)	Digital Input 1	-300.00 to 300.00 %	0.01%	cv	
105	RW	Destination Tag	SYSTEM::CONFIGURE I/O::DIGITAL INPUTS::DIGIN 2 (C7)	Digital Input 2	0 to 549	118	cx	2, 3
107	RW	Value For False	SYSTEM::CONFIGURE I/O::DIGITAL INPUTS::DIGIN 2 (C7)	Digital Input 2	-300.00 to 300.00 %	0.00%	cz	
106	RW	Value For True	SYSTEM::CONFIGURE I/O::DIGITAL INPUTS::DIGIN 2 (C7)	Digital Input 2	-300.00 to 300.00 %	0.01%	cy	
108	RW	Destination Tag	SYSTEM::CONFIGURE I/O::DIGITAL INPUTS::DIGIN 3 (C8)	Digital Input 3	0 to 549	119	d0	2, 3
110	RW	Value For False	SYSTEM::CONFIGURE I/O::DIGITAL INPUTS::DIGIN 3 (C8)	Digital Input 3	-300.00 to 300.00 %	0.00%	d2	
109	RW	Value For True	SYSTEM::CONFIGURE I/O::DIGITAL INPUTS::DIGIN 3 (C8)	Digital Input 3	-300.00 to 300.00 %	0.01%	d1	
494	RW	Destination Tag	SYSTEM::CONFIGURE I/O::DIGITAL INPUTS::DIGITAL INPUT C4	Dig in C4	0 to 549	496	nq	2, 3
495	RW	Destination Tag	SYSTEM::CONFIGURE I/O::DIGITAL INPUTS::DIGITAL INPUT C5	Dig in C5	0 to 549	497	nr	2, 3
359	RW	Inverted	SYSTEM::CONFIGURE I/O::DIGITAL OUTPUTS::DIGOUT 1 (B5)	Digout 1 (B5)	0 : False 1 : True	FALSE	jz	
43	RW	Modulus	SYSTEM::CONFIGURE I/O::DIGITAL OUTPUTS::DIGOUT 1 (B5)	Digout 1 (B5)	0 : False 1 : True	TRUE	b7	
97	RW	Source Tag	SYSTEM::CONFIGURE I/O::DIGITAL OUTPUTS::DIGOUT 1 (B5)	Digout 1 (B5)	0 to 549	77	cp	2, 3
195	RW	Threshold (>)	SYSTEM::CONFIGURE I/O::DIGITAL OUTPUTS::DIGOUT 1 (B5)	Digout 1 (B5)	-300.00 to 300.00 %	0.00%	ff	2
360	RW	Inverted	SYSTEM::CONFIGURE I/O::DIGITAL OUTPUTS::DIGOUT 2 (B6)	Digout 2 (B6)	0 : False 1 : True	FALSE	k0	
44	RW	Modulus	SYSTEM::CONFIGURE I/O::DIGITAL OUTPUTS::DIGOUT 2 (B6)	Digout 2 (B6)	0 : False 1 : True	TRUE	b8	
98	RW	Source Tag	SYSTEM::CONFIGURE I/O::DIGITAL OUTPUTS::DIGOUT 2 (B6)	Digout 2 (B6)	0 to 549	122	cq	2, 3
196	RW	Threshold (>)	SYSTEM::CONFIGURE I/O::DIGITAL OUTPUTS::DIGOUT 2 (B6)	Digout 2 (B6)	-300.00 to 300.00 %	0.00%	fg	2
361	RW	Inverted	SYSTEM::CONFIGURE I/O::DIGITAL OUTPUTS::DIGOUT 3 (B7)	Digout 3 (B7)	0 : False 1 : True	FALSE	k1	
45	RW	Modulus	SYSTEM::CONFIGURE I/O::DIGITAL OUTPUTS::DIGOUT 3 (B7)	Digout 3 (B7)	0 : False 1 : True	TRUE	b9	
99	RW	Source Tag	SYSTEM::CONFIGURE I/O::DIGITAL OUTPUTS::DIGOUT 3 (B7)	Digout 3 (B7)	0 to 549	125	cr	2, 3
197	RW	Threshold (>)	SYSTEM::CONFIGURE I/O::DIGITAL OUTPUTS::DIGOUT 3 (B7)	Digout 3 (B7)	-300.00 to 300.00 %	0.00%	fh	2
365	RW	Destination Tag	SYSTEM::CONFIGURE I/O::INTERNAL LINKS::LINK 1	Link 1	0 to 549	0	k5	2, 3
364	RW	Source Tag	SYSTEM::CONFIGURE I/O::INTERNAL LINKS::LINK 1	Link 1	0 to 549	0	k4	2, 3

Table B-3 Parameters Listed by Keypad Menu Continued

Tag	R/W	Name	Keypad Menu	WB Block	Range	Factory Setting	MN	Notes
470	RW	Destination Tag	SYSTEM::CONFIGURE I/O::INTERNAL LINKS::LINK 10	Link 10	0 to 549	0	n2	2, 3
469	RW	Source Tag	SYSTEM::CONFIGURE I/O::INTERNAL LINKS::LINK 10	Link 10	0 to 549	0	n1	2, 3
367	RW	Destination Tag	SYSTEM::CONFIGURE I/O::INTERNAL LINKS::LINK 2	Link 2	0 to 549	0	k7	2, 3
366	RW	Source Tag	SYSTEM::CONFIGURE I/O::INTERNAL LINKS::LINK 2	Link 2	0 to 549	0	k6	2, 3
369	RW	Destination Tag	SYSTEM::CONFIGURE I/O::INTERNAL LINKS::LINK 3	Link 3	0 to 549	0	k9	2, 3
368	RW	Source Tag	SYSTEM::CONFIGURE I/O::INTERNAL LINKS::LINK 3	Link 3	0 to 549	0	k8	2, 3
371	RW	Destination Tag	SYSTEM::CONFIGURE I/O::INTERNAL LINKS::LINK 4	Link 4	0 to 549	0	kb	2, 3
370	RW	Source Tag	SYSTEM::CONFIGURE I/O::INTERNAL LINKS::LINK 4	Link 4	0 to 549	0	ka	2, 3
455	RW	Destination Tag	SYSTEM::CONFIGURE I/O::INTERNAL LINKS::LINK 5	Link 5	0 to 549	0	mn	2, 3
454	RW	Source Tag	SYSTEM::CONFIGURE I/O::INTERNAL LINKS::LINK 5	Link 5	0 to 549	0	m m	2, 3
457	RW	Destination Tag	SYSTEM::CONFIGURE I/O::INTERNAL LINKS::LINK 6	Link 6	0 to 549	0	mp	2, 3
456	RW	Source Tag	SYSTEM::CONFIGURE I/O::INTERNAL LINKS::LINK 6	Link 6	0 to 549	0	mo	2, 3
459	RW	Destination Tag	SYSTEM::CONFIGURE I/O::INTERNAL LINKS::LINK 7	Link 7	0 to 549	0	mr	2, 3
458	RW	Source Tag	SYSTEM::CONFIGURE I/O::INTERNAL LINKS::LINK 7	Link 7	0 to 549	0	mq	2, 3
461	RW	Destination Tag	SYSTEM::CONFIGURE I/O::INTERNAL LINKS::LINK 8	Link 8	0 to 549	0	mt	2, 3
460	RW	Source Tag	SYSTEM::CONFIGURE I/O::INTERNAL LINKS::LINK 8	Link 8	0 to 549	0	ms	2, 3
468	RW	Destination Tag	SYSTEM::CONFIGURE I/O::INTERNAL LINKS::LINK 9	Link 9	0 to 549	0	n0	2, 3
467	RW	Source Tag	SYSTEM::CONFIGURE I/O::INTERNAL LINKS::LINK 9	Link 9	0 to 549	0	mz	2, 3
123	RW	Peek Data	SYSTEM::PEEK		0x0000 to 0xFFFF	0x0078	df	
124	RW	Peek Scale	SYSTEM::PEEK		-300.00 to 300.00	8.00	dg	

Parameter Values Continued R/W: RO = Read Only, RW = Read / Write

Table B-4 Parameters Listed by WB Block

Tag	R/W	Name	Keypad Menu	WB Block	Range	Factory Setting	MN	Notes	
543	RW	Zero CAL Inputs	CONFIGURE DRIVE		Up To Action Requested		p3	1, 2, 3, 4	
121	RW	Change Password	PASSWORD		0x0000 to 0xFFFF	0x0000	dd		
120	RW	Enter Password	PASSWORD		0x0000 to 0xFFFF	0x0000	dc	1	
198	RW	P3 Baud Rate	SERIAL LINKS::SYSTEM PORT (P3)::P3 SET-UP		0:300 1:600 2:1200 3:2400 4:4800 5:9600 6:19200	9600	fi	2	
123	RW	Peek Data	SYSTEM::PEEK		0x0000 to 0xFFFF	0x0078	df		
124	RW	Peek Scale	SYSTEM::PEEK		-300.00 to 300.00	8.00	dg		
187	RO	Raw Input	SERIAL LINKS::SYSTEM PORT (P3)::P3 SET-UP::5703 SUPPORT	5703	xxx.xx %	0.00%	f7	Output	
189	RO	Scaled Input	SERIAL LINKS::SYSTEM PORT (P3)::P3 SET-UP::5703 SUPPORT	5703	xxx.xx %	0.00%	f9	Output, 2	
132	RW	SETPT. RATIO	SERIAL LINKS::SYSTEM PORT (P3)::P3 SET-UP::5703 SUPPORT	5703	-3.0000 to 3.0000	0.0000	do		
133	RW	SETPT. SIGN	SERIAL LINKS::SYSTEM PORT (P3)::P3 SET-UP::5703 SUPPORT	5703	0 : Negative 1 : Positive	Positive	dp		
134	RW	Source Tag	SYSTEM::CONFIGURE I/O::CONFIGURE 5703	5703	0 to 549	89	dq	2, 3	
274	RW	I GAIN IN RAMP	SETUP PARAMETERS::SPEED LOOP::ADVANCED	Advanced	0.0000 to 2.0000	1.0000	hm		
273	RW	POS. LOOP P GAIN	SETUP PARAMETERS::SPEED LOOP::ADVANCED	Advanced	-200.00 to 200.00 %	0.00%	hl	4	
268	RW	Mode	SETUP PARAMETERS::SPEED LOOP::ADVANCED::ADAPTION	Advanced	0 to 3	0	hg		
271	RW	PROP. GAIN	SETUP PARAMETERS::SPEED LOOP::ADVANCED::ADAPTION	Advanced	0.00 to 200.00	5.00	hj		
269	RW	SPD BRK1 (LOW)	SETUP PARAMETERS::SPEED LOOP::ADVANCED::ADAPTION	Advanced	0.00 to 100.00 %	1.00%	hh		
270	RW	SPD BRK2 (HIGH)	SETUP PARAMETERS::SPEED LOOP::ADVANCED::ADAPTION	Advanced	0.00 to 100.00 %	5.00%	hi		
272	RW	SPD.INT.TIME	SETUP PARAMETERS::SPEED LOOP::ADVANCED::ADAPTION	Advanced	0.001 to 30.000 Secs	0.500 Secs	hk		
285	RW	ZERO IAD LEVEL	SETUP PARAMETERS::SPEED LOOP::ADVANCED::ZERO SPD. QUENCH	Advanced	0.00 to 200.00 %	1.50%	hx		
284	RW	ZERO SPD. LEVEL	SETUP PARAMETERS::SPEED LOOP::ADVANCED::ZERO SPD. QUENCH	Advanced	0.00 to 200.00 %	0.50%	hw		
116	RO	Health Store	ALARM STATUS	Alarms	0x0000 to 0xFFFF	0x0000	d8	Output	
115	RO	Health Word	ALARM STATUS	Alarms	0x0000 to 0xFFFF	0x0200	d7	Output	
528	RO	Last Alarm	ALARM STATUS	Alarms	0x0000 : No Active Alarms 0x0001 : Over Speed 0x0002 : Missing Pulse 0x0004 : Field Over I 0x0008 : Heatsink Trip 0x0010 : Thermistor 0x0020 : Over Volts (VA) 0x0040 : SPD Feed back 0x0080 : Encoder Failed 0x0100 : Field Failed 0x0200 : 3 Phase Failed 0x0400 : Phase Lock 0x0800 : 5703 RCV Error 0x1000 : Stall Trip 0x2000 : Over I Trip 0xf005 : External Trip 0x8000 : Accts Failed 0xf001 : Autotune Error 0xf002 : Autotune Aborted 0xf200 : Config Enabled 0xf400 : No Keypad 0xf006 : Remote Trip 0xff05 : PCB Version 0xff06 : Product Code	No Active Alarms	Alarms	oo	Output, 1

Table B-4 Parameters Listed by WB Block Continued

Tag	R/W	Name	Keypad Menu	WB Block	Range	Factory Setting	MN	Notes
542	RO	Remote Trip	ALARM STATUS	Alarms	0 : False 1 : True	FALSE	p2	Output, 1
112	RO	Stall Trip	ALARM STATUS	Alarms	0 : OK 1 : Failed	OK	d4	Output
122	RO	Health LED	DIAGNOSTICS	Alarms	0 : False 1 : True	True	de	Output
125	RO	Ready	DIAGNOSTICS	Alarms	0 : False 1 : True	False	dh	Output
541	RW	REM Trip Delay	SETUP PARAMETERS::CALIBRATION	Alarms	0.1 to 600.0 Secs	10.0 Secs	p1	
111	RW	5703 RCV ERROR	SETUP PARAMETERS::INHIBIT ALARMS	Alarms	0 : Enabled 1 : Inhibited	Enabled	d3	
92	RW	Encoder Alarm	SETUP PARAMETERS::INHIBIT ALARMS	Alarms	0 : Enabled 1 : Inhibited	Enabled	ck	
19	RW	Field Fail	SETUP PARAMETERS::INHIBIT ALARMS	Alarms	0 : Enabled 1 : Inhibited	Enabled	aj	
540	RW	REM Trip Inhibit	SETUP PARAMETERS::INHIBIT ALARMS	Alarms	0 : Enabled 1 : Inhibited	Enabled	p0	
81	RW	SPEED FBK ALARM	SETUP PARAMETERS::INHIBIT ALARMS	Alarms	0 : Enabled 1 : Inhibited	Enabled	c9	
28	RW	Stall Trip	SETUP PARAMETERS::INHIBIT ALARMS	Alarms	0 : Enabled 1 : Inhibited	Inhibited	as	
305	RW	Trip Reset	SETUP PARAMETERS::INHIBIT ALARMS	Alarms	0 : False 1 : True	TRUE	ih	
50	RO	ANIN 1 (A2)	DIAGNOSTICS	Analog Input 1	xxx.xx VOLTS	0.00V	be	Output
230	RW	Calibration	SYSTEM::CONFIGURE I/O::ANALOG INPUTS::ANIN 1 (A2)	Analog Input 1	-3.0000 to 3.0000	1.0000	ge	
246	RW	Destination Tag	SYSTEM::CONFIGURE I/O::ANALOG INPUTS::ANIN 1 (A2)	Analog Input 1	0 to 549	100	gu	2, 3
231	RW	Max Value	SYSTEM::CONFIGURE I/O::ANALOG INPUTS::ANIN 1 (A2)	Analog Input 1	-300.00 to 300.00 %	100.00%	gf	
232	RW	Min Value	SYSTEM::CONFIGURE I/O::ANALOG INPUTS::ANIN 1 (A2)	Analog Input 1	-300.00 to 300.00 %	-100.00%	gg	
51	RO	ANIN 2 (A3)	DIAGNOSTICS	Analog Input 2	xxx.xx VOLTS	0.00V	bf	Output
233	RW	Calibration	SYSTEM::CONFIGURE I/O::ANALOG INPUTS::ANIN 2 (A3)	Analog Input 2	-3.0000 to 3.0000	1.0000	gh	
234	RW	Max Value	SYSTEM::CONFIGURE I/O::ANALOG INPUTS::ANIN 2 (A3)	Analog Input 2	-300.00 to 300.00 %	100.00%	gi	
235	RW	Min Value	SYSTEM::CONFIGURE I/O::ANALOG INPUTS::ANIN 2 (A3)	Analog Input 2	-300.00 to 300.00 %	-100.00%	gj	
493	RO	Output	SYSTEM::CONFIGURE I/O::ANALOG INPUTS::ANIN 2 (A3)	Analog Input 2	xxx.xx %	0.00%	np	Output, 2
52	RO	ANIN 3 (A4)	DIAGNOSTICS	Analog Input 3	xxx.xx VOLTS	0.00V	bg	Output
236	RW	Calibration	SYSTEM::CONFIGURE I/O::ANALOG INPUTS::ANIN 3 (A4)	Analog Input 3	-3.0000 to 3.0000	1.0000	gk	
249	RW	Destination Tag	SYSTEM::CONFIGURE I/O::ANALOG INPUTS::ANIN 3 (A4)	Analog Input 3	0 to 549	5	gx	2, 3
237	RW	Max Value	SYSTEM::CONFIGURE I/O::ANALOG INPUTS::ANIN 3 (A4)	Analog Input 3	-300.00 to 300.00 %	100.00%	gl	
238	RW	Min Value	SYSTEM::CONFIGURE I/O::ANALOG INPUTS::ANIN 3 (A4)	Analog Input 3	-300.00 to 300.00 %	-100.00%	gm	
53	RO	ANIN 4 (A5)	DIAGNOSTICS	Analog Input 4	xxx.xx VOLTS	0.00V	bh	Output
239	RW	Calibration	SYSTEM::CONFIGURE I/O::ANALOG INPUTS::ANIN 4 (A5)	Analog Input 4	-3.0000 to 3.0000	1.0000	gn	
250	RW	Destination Tag	SYSTEM::CONFIGURE I/O::ANALOG INPUTS::ANIN 4 (A5)	Analog Input 4	0 to 549	48	gy	2, 3
240	RW	Max Value	SYSTEM::CONFIGURE I/O::ANALOG INPUTS::ANIN 4 (A5)	Analog Input 4	-300.00 to 300.00 %	100.00%	go	
241	RW	Min Value	SYSTEM::CONFIGURE I/O::ANALOG INPUTS::ANIN 4 (A5)	Analog Input 4	-300.00 to 300.00 %	-100.00%	gp	
54	RO	ANIN 5 (A6)	DIAGNOSTICS	Analog Input 5	xxx.xx VOLTS	10.00V	bi	Output
242	RW	Calibration	SYSTEM::CONFIGURE I/O::ANALOG INPUTS::ANIN 5 (A6)	Analog Input 5	-3.0000 to 3.0000	1.0000	gq	
247	RW	Destination Tag	SYSTEM::CONFIGURE I/O::ANALOG INPUTS::ANIN 5 (A6)	Analog Input 5	0 to 549	301	gv	2, 3
243	RW	Max Value	SYSTEM::CONFIGURE I/O::ANALOG INPUTS::ANIN 5 (A6)	Analog Input 5	-300.00 to 300.00 %	200.00%	gr	
244	RW	Min Value	SYSTEM::CONFIGURE I/O::ANALOG INPUTS::ANIN 5 (A6)	Analog Input 5	-300.00 to 300.00 %	-200.00%	gs	
55	RO	ANOUT 1 (A7)	DIAGNOSTICS	Analog Output 1	xxx.xx VOLTS (h)	0.00V	bj	Output
245	RW	% TO GET 10V	SYSTEM::CONFIGURE I/O::ANALOG OUTPUTS::ANOUT 1 (A7)	Analog Output 1	-300.00 to 300.00 %	100.00%	gt	
362	RW	Modulus	SYSTEM::CONFIGURE I/O::ANALOG OUTPUTS::ANOUT 1 (A7)	Analog Output 1	0 : False 1 : True	FALSE	k2	

Table B-4 Parameters Listed by WB Block Continued

Tag	R/W	Name	Keypad Menu	WB Block	Range	Factory Setting	MN	Notes
464	RW	Offset	SYSTEM::CONFIGURE I/O::ANALOG OUTPUTS::ANOUT 1 (A7)	Analog Output 1	-100.00 to 100.00 %	0.00%	mw	
251	RW	Source Tag	SYSTEM::CONFIGURE I/O::ANALOG OUTPUTS::ANOUT 1 (A7)	Analog Output 1	0 to 549	62	gz	2, 3
56	RO	ANOUT 2 (A8)	DIAGNOSTICS	Analog Output 2	xxx.xx VOLTS (h)	0.00V	bk	Output
248	RW	% TO GET 10V	SYSTEM::CONFIGURE I/O::ANALOG OUTPUTS::ANOUT 2 (A8)	Analog Output 2	-300.00 to 300.00 %	100.00%	gw	
363	RW	Modulus	SYSTEM::CONFIGURE I/O::ANALOG OUTPUTS::ANOUT 2 (A8)	Analog Output 2	0 : False 1 : True	FALSE	k3	
465	RW	Offset	SYSTEM::CONFIGURE I/O::ANALOG OUTPUTS::ANOUT 2 (A8)	Analog Output 2	-100.00 to 100.00 %	0.00%	mx	
252	RW	Source Tag	SYSTEM::CONFIGURE I/O::ANALOG OUTPUTS::ANOUT 2 (A8)	Analog Output 2	0 to 549	63	h0	2, 3
69	RO	Digital Input C4	DIAGNOSTICS	Aux I/O	0 : Off 1 : On	Off	bx	Output
70	RO	Digital Input C5	DIAGNOSTICS	Aux I/O	0 : Off 1 : On	On	by	Output
68	RO	Start (C3)	DIAGNOSTICS	Aux I/O	0 : Off 1 : On	Off	bw	Output
128	RW	ANOUT 1	SETUP PARAMETERS::AUX I/O	Aux I/O	-100.00 to 100.00 %	0.00%	dk	
129	RW	ANOUT 2	SETUP PARAMETERS::AUX I/O	Aux I/O	-100.00 to 100.00 %	0.00%	dl	
94	RW	AUX DIGOUT 1	SETUP PARAMETERS::AUX I/O	Aux I/O	0 : Off 1 : On	Off	cm	
95	RW	AUX DIGOUT 2	SETUP PARAMETERS::AUX I/O	Aux I/O	0 : Off 1 : On	Off	cn	
96	RW	AUX DIGOUT 3	SETUP PARAMETERS::AUX I/O	Aux I/O	0 : Off 1 : On	Off	co	
168	RW	Aux Enable	SETUP PARAMETERS::AUX I/O	Aux I/O	0 : Off 1 : On	On	eo	
227	RW	AUX JOG	SETUP PARAMETERS::AUX I/O	Aux I/O	0 : Off 1 : On	On	gb	
161	RW	AUX START	SETUP PARAMETERS::AUX I/O	Aux I/O	0 : Off 1 : On	On	eh	
497	RO	Enable	SETUP PARAMETERS::AUX I/O	Aux I/O	0 : Off 1 : On	On	nt	Output
496	RO	Jog/Slack	SETUP PARAMETERS::AUX I/O	Aux I/O	0 : Off 1 : On	Off	ns	Output
535	RW	REM.SEQ.ENABLE	SETUP PARAMETERS::AUX I/O	Aux I/O	0 : False, 1 : True	FALSE	ov	2
536	RO	REM.SEQUENCE	SETUP PARAMETERS::AUX I/O	Aux I/O	0x0000 to 0xFFFF	0x0000	ow	1
537	RO	SEQ Status	SETUP PARAMETERS::AUX I/O	Aux I/O	0x0000 to 0xFFFF	0x0C03	ox	Output
523	RW	Armature Current	CONFIGURE DRIVE	Calibration	2.0 to 15.0 AMPS	2.0 AMPS	oj	3
24	RW	Encoder Lines	CONFIGURE DRIVE	Calibration	10 to 5000	1024	ao	2
22	RW	Encoder RPM	CONFIGURE DRIVE	Calibration	0 to 6000 RPM	1750 RPM	am	
524	RW	Field Current	CONFIGURE DRIVE	Calibration	0.2 to 4.0 AMPS	0.2 AMPS	ok	3
521	RW	NOM Motor Volts	CONFIGURE DRIVE	Calibration	100 to 875 Volts	500 Volts	oh	3
60	RO	BACK EMF	DIAGNOSTICS	Calibration	xxx.xx % (h)	0.0%	bo	Output
57	RO	Terminal Volts	DIAGNOSTICS	Calibration	xxx.xx % (h)	0.0%	bl	Output
181	RO	Unfil. Field FBK	DIAGNOSTICS	Calibration	xxx.xx %	0.00%	f1	Output
59	RO	UNFIL.ENCODER	DIAGNOSTICS	Calibration	xxxxx RPM	0 RPM	bn	Output
58	RO	UNFIL.TACH INPUT	DIAGNOSTICS	Calibration	xxx.xx % (h)	0.0%	bm	Output
23	RW	Analog TACH CAL	SETUP PARAMETERS::CALIBRATION	Calibration	0.9800 to 1.1000	1.0000	an	
25	RW	Armature I (A9)	SETUP PARAMETERS::CALIBRATION	Calibration	0 : UNIPOLAR 1 : BIPOLAR	Bipolar	ap	
20	RW	Armature V CAL.	SETUP PARAMETERS::CALIBRATION	Calibration	0.9800 to 1.1000	1.0000	ak	
182	RW	Field I CAL.	SETUP PARAMETERS::CALIBRATION	Calibration	0.9800 to 1.1000	1.0000	f2	
21	RW	IR Compensation	SETUP PARAMETERS::CALIBRATION	Calibration	0.00 to 100.00 %	0.00%	al	
188	RW	Over Speed Level	SETUP PARAMETERS::CALIBRATION	Calibration	0.00 to 200.00 %	125.00%	f8	4
180	RW	SPDFBK ALM LEVEL	SETUP PARAMETERS::CALIBRATION	Calibration	0.00 to 100.00 % (h)	50.00%	f0	
263	RW	Stall Threshold	SETUP PARAMETERS::CALIBRATION	Calibration	0.00 to 200.00 %	95.00%	hb	
224	RW	Stall Trip Delay	SETUP PARAMETERS::CALIBRATION	Calibration	0.1 to 600.0 Secs	10.0 Secs	g8	
10	RW	Zero SPD. Offset	SETUP PARAMETERS::CALIBRATION	Calibration	-5.00 to 5.00 %	0.00%	aa	
18	RO	Autotune	CONFIGURE DRIVE	Current Loop	0 : Off 1 : On	Off	ai	Output, 1
15	RW	CUR.LIMIT/SCALER	CONFIGURE DRIVE	Current Loop	0.00 to 200.00 %	90.00%	af	
42	RO	At Current Limit	DIAGNOSTICS	Current Loop	0 : False 1 : True	False	b6	Output
538	RO	Current FBK.Amps	DIAGNOSTICS	Current Loop	xxxx.x AMPS	0.0 AMPS	oy	Output, 1, 3
539	RO	Field I FBK.AMPS	DIAGNOSTICS	Current Loop	xxxx.x AMPS	0.0 AMPS	oz	Output, 1, 3
66	RO	IaDmd UNFILTERED	DIAGNOSTICS	Current Loop	xxx.xx % (h)	0.0%	bu	Output
65	RO	IaFbk UNFILTERED	DIAGNOSTICS	Current Loop	xxx.xx % (h)	0.0%	bt	Output
30	RW	Additional DEM	SETUP PARAMETERS::CURRENT LOOP	Current Loop	-200.00 to 200.00 %	0.00%	au	
90	RW	Bipolar Clamps	SETUP PARAMETERS::CURRENT LOOP	Current Loop	0 : Disabled 1 : Enabled	Disabled	ci	
137	RW	Discontinuous	SETUP PARAMETERS::CURRENT LOOP	Current Loop	0.00 to 200.00 %	12.00%	dt	
136	RW	Feed Forward	SETUP PARAMETERS::CURRENT LOOP	Current Loop	0.10 to 50.00	2.00	ds	4

Table B-4 Parameters Listed by WB Block Continued

Tag	R/W	Name	Keypad Menu	WB Block	Range	Factory Setting	MN	Notes
119	RW	I DMD. ISOLATE	SETUP PARAMETERS::CURRENT LOOP	Current Loop	0 : Disabled 1 : Enabled	Disabled	db	
17	RW	INT. GAIN	SETUP PARAMETERS::CURRENT LOOP	Current Loop	0.00 to 200.00	3.50	ah	
421	RW	MAIN CURR. LIMIT	SETUP PARAMETERS::CURRENT LOOP	Current Loop	0.00 to 200.00 %	200.00%	lp	
527	RO	Master Bridge	SETUP PARAMETERS::CURRENT LOOP	Current Loop	0 : Off 1 : On	Off	on	Output, 1
48	RW	NEG. I CLAMP	SETUP PARAMETERS::CURRENT LOOP	Current Loop	-100.00 to 100.00 %	0.00%	bc	
301	RW	POS. I CLAMP	SETUP PARAMETERS::CURRENT LOOP	Current Loop	-100.00 to 100.00 %	100.00%	id	
16	RW	PROP. GAIN	SETUP PARAMETERS::CURRENT LOOP	Current Loop	0.00 to 200.00	45.00	ag	
201	RW	Regen Mode	SETUP PARAMETERS::CURRENT LOOP	Current Loop	0 : 2Q (Non-regen) 1 : 4Q (Regen)	2Q(Non-regen)	fl	2
93	RW	IMAX BRK1 (SPD1)	SETUP PARAMETERS::CURRENT PROFILE	Current Profile	0.00 to 200.00 % (h)	200.00%	cl	2
33	RW	IMAX BRK2 (SPD2)	SETUP PARAMETERS::CURRENT PROFILE	Current Profile	0.00 to 200.00 % (h)	200.00%	ax	2
32	RW	SPD BRK1 (LOW)	SETUP PARAMETERS::CURRENT PROFILE	Current Profile	0.00 to 100.00 % (h)	100.00%	aw	2
31	RW	SPD BRK2 (HIGH)	SETUP PARAMETERS::CURRENT PROFILE	Current Profile	0.00 to 100.00 % (h)	100.00%	av	2
61	RO	ACTUAL NEG I LIM	DIAGNOSTICS	Diagnostics	xxx.xx % (h)	-90.0%	bp	Output
67	RO	ACTUAL POS I LIM	DIAGNOSTICS	Diagnostics	xxx.xx % (h)	90.00%	bv	Output
299	RO	Current Demand	DIAGNOSTICS	Diagnostics	xxx.xx %	0.00%	ib	Output
298	RO	Current Feedback	DIAGNOSTICS	Diagnostics	xxx.xx %	0.00%	ia	Output
84	RO	Drive Enable	DIAGNOSTICS	Diagnostics	0 : Disabled 1 : Enabled	Disabled	cc	Output
82	RO	Drive Start	DIAGNOSTICS	Diagnostics	0 : Off 1 : On	Off	ca	Output
206	RO	Encoder	DIAGNOSTICS	Diagnostics	xxxxx RPM	0 RPM	fq	Output
300	RO	FIELD I FBK.	DIAGNOSTICS	Diagnostics	xxx.xx %	0.00%	ic	Output
88	RO	NEG. I CLAMP	DIAGNOSTICS	Diagnostics	xxx.xx % (h)	-90.0%	cg	Output
87	RO	POS. I CLAMP	DIAGNOSTICS	Diagnostics	xxx.xx % (h)	90.0%	cf	Output
297	RO	Speed Error	DIAGNOSTICS	Diagnostics	xxx.xx %	-0.01%	i9	Output
207	RO	Speed Feedback	DIAGNOSTICS	Diagnostics	xxx.xx %	0.01%	fr	Output
308	RO	Tach Input	DIAGNOSTICS	Diagnostics	xxx.xx % (h)	0.0%	ik	Output
494	RW	Destination Tag	SYSTEM::CONFIGURE I/O::DIGITAL IN-PUTS::DIGITAL INPUT C4	Dig in C4	0 to 549	496	nq	2, 3
495	RW	Destination Tag	SYSTEM::CONFIGURE I/O::DIGITAL IN-PUTS::DIGITAL INPUT C5	Dig in C5	0 to 549	497	nr	2, 3
71	RO	DIGIN 1 (C6)	DIAGNOSTICS	Digital Input 1	0 : Off 1 : On	Off	bz	Output
102	RW	Destination Tag	SYSTEM::CONFIGURE I/O::DIGITAL IN-PUTS::DIGIN 1 (C6)	Digital Input 1	0 to 549	90	cu	2, 3
104	RW	Value For False	SYSTEM::CONFIGURE I/O::DIGITAL IN-PUTS::DIGIN 1 (C6)	Digital Input 1	-300.00 to 300.00 %	0.00%	cw	
103	RW	Value For True	SYSTEM::CONFIGURE I/O::DIGITAL IN-PUTS::DIGIN 1 (C6)	Digital Input 1	-300.00 to 300.00 %	0.01%	cv	
72	RO	DIGIN 2 (C7)	DIAGNOSTICS	Digital Input 2	0 : Off 1 : On	Off	c0	Output
105	RW	Destination Tag	SYSTEM::CONFIGURE I/O::DIGITAL IN-PUTS::DIGIN 2 (C7)	Digital Input 2	0 to 549	118	cx	2, 3
107	RW	Value For False	SYSTEM::CONFIGURE I/O::DIGITAL IN-PUTS::DIGIN 2 (C7)	Digital Input 2	-300.00 to 300.00 %	0.00%	cz	
106	RW	Value For True	SYSTEM::CONFIGURE I/O::DIGITAL IN-PUTS::DIGIN 2 (C7)	Digital Input 2	-300.00 to 300.00 %	0.01%	cy	
73	RO	DIGIN 3 (C8)	DIAGNOSTICS	Digital Input 3	0 : Off 1 : On	Off	c1	Output
108	RW	Destination Tag	SYSTEM::CONFIGURE I/O::DIGITAL IN-PUTS::DIGIN 3 (C8)	Digital Input 3	0 to 549	119	d0	2, 3
110	RW	Value For False	SYSTEM::CONFIGURE I/O::DIGITAL IN-PUTS::DIGIN 3 (C8)	Digital Input 3	-300.00 to 300.00 %	0.00%	d2	
109	RW	Value For True	SYSTEM::CONFIGURE I/O::DIGITAL IN-PUTS::DIGIN 3 (C8)	Digital Input 3	-300.00 to 300.00 %	0.01%	d1	
74	RO	DIGOUT 1 (B5)	DIAGNOSTICS	Digout 1 (B5)	0 : Off 1 : On	On	c2	Output
359	RW	Inverted	SYSTEM::CONFIGURE I/O::DIGITAL OUT-PUTS::DIGOUT 1 (B5)	Digout 1 (B5)	0 : False 1 : True	FALSE	jz	
43	RW	Modulus	SYSTEM::CONFIGURE I/O::DIGITAL OUT-PUTS::DIGOUT 1 (B5)	Digout 1 (B5)	0 : False 1 : True	TRUE	b7	
97	RW	Source Tag	SYSTEM::CONFIGURE I/O::DIGITAL OUT-PUTS::DIGOUT 1 (B5)	Digout 1 (B5)	0 to 549	77	cp	2, 3
195	RW	Threshold (>)	SYSTEM::CONFIGURE I/O::DIGITAL OUT-PUTS::DIGOUT 1 (B5)	Digout 1 (B5)	-300.00 to 300.00 %	0.00%	ff	2
75	RO	DIGOUT 2 (B6)	DIAGNOSTICS	Digout 2 (B6)	0 : Off 1 : On	On	c3	Output

Table B-4 Parameters Listed by WB Block Continued

Tag	R/W	Name	Keypad Menu	WB Block	Range	Factory Setting	MN	Notes
360	RW	Inverted	SYSTEM::CONFIGURE I/O::DIGITAL OUTPUTS::DIGOUT 2 (B6)	Digout 2 (B6)	0 : False 1 : True	FALSE	k0	
44	RW	Modulus	SYSTEM::CONFIGURE I/O::DIGITAL OUTPUTS::DIGOUT 2 (B6)	Digout 2 (B6)	0 : False 1 : True	TRUE	b8	
98	RW	Source Tag	SYSTEM::CONFIGURE I/O::DIGITAL OUTPUTS::DIGOUT 2 (B6)	Digout 2 (B6)	0 to 549	122	cq	2, 3
196	RW	Threshold (>)	SYSTEM::CONFIGURE I/O::DIGITAL OUTPUTS::DIGOUT 2 (B6)	Digout 2 (B6)	-300.00 to 300.00 %	0.00%	fg	2
76	RO	DIGOUT 3 (B7)	DIAGNOSTICS	Digout 3 (B7)	0 : Off 1 : On	Off	c4	Output
361	RW	Inverted	SYSTEM::CONFIGURE I/O::DIGITAL OUTPUTS::DIGOUT 3 (B7)	Digout 3 (B7)	0 : False 1 : True	FALSE	k1	
45	RW	Modulus	SYSTEM::CONFIGURE I/O::DIGITAL OUTPUTS::DIGOUT 3 (B7)	Digout 3 (B7)	0 : False 1 : True	TRUE	b9	
99	RW	Source Tag	SYSTEM::CONFIGURE I/O::DIGITAL OUTPUTS::DIGOUT 3 (B7)	Digout 3 (B7)	0 to 549	125	cr	2, 3
197	RW	Threshold (>)	SYSTEM::CONFIGURE I/O::DIGITAL OUTPUTS::DIGOUT 3 (B7)	Digout 3 (B7)	-300.00 to 300.00 %	0.00%	fh	2
209	RW	FLD.CTRL MODE	CONFIGURE DRIVE	Field Control	0 : Voltage Control 1 : Current Control	Voltage Control	ft	2
210	RW	FLD.VOLTS RATIO	CONFIGURE DRIVE	Field Control	0.00 to 100.00 % (h)	67.0%	fu	
183	RO	Field Demand	DIAGNOSTICS	Field Control	xxx.xx %	0.00%	f3	Output
169	RO	Field Enabled	DIAGNOSTICS	Field Control	0 : Disabled 1 : Enabled	Disabled	ep	Output
184	RO	FLD.FIRING ANGLE	DIAGNOSTICS	Field Control	xxx.xx DEG	0.00 Deg	f4	Output
170	RW	Field Enable	SETUP PARAMETERS::FIELD CONTROL	Field Control	0 : Disabled 1 : Enabled	Enabled	eq	2
617	RW	Field I Thresh	SETUP PARAMETERS::FIELD CONTROL	Field Control	0.00 to 100.00 %	80.00%		
186	RW	FLD. QUENCH MODE	SETUP PARAMETERS::FIELD CONTROL	Field Control	0 : Quench 1 : Standby	Quench	f6	
185	RW	FLD.QUENCH DELAY	SETUP PARAMETERS::FIELD CONTROL	Field Control	0.0 to 600.0 Secs	0.0 Secs	f5	
618	RO	Up To Field	SETUP PARAMETERS::FIELD CONTROL	Field Control	0 : False 1 : True	False		Output
172	RW	INT. GAIN	SETUP PARAMETERS::FIELD CONTROL::FLD.CURRENT VARS	Field Control	0.00 to 100.00	1.28	es	
173	RW	PROP. GAIN	SETUP PARAMETERS::FIELD CONTROL::FLD.CURRENT VARS	Field Control	0.00 to 100.00	0.10	et	
171	RW	Setpoint	SETUP PARAMETERS::FIELD CONTROL::FLD.CURRENT VARS	Field Control	0.00 to 100.00 %	100.00%	er	
192	RW	BEMF FBK LAG	SETUP PARAMETERS::FIELD CONTROL::FLD.CURRENT VARS::FLD.WEAK VARS	Field Control	10 to 5000	100	fc	
191	RW	BEMF FBK LEAD	SETUP PARAMETERS::FIELD CONTROL::FLD.CURRENT VARS::FLD.WEAK VARS	Field Control	10 to 5000	100	fb	
177	RW	EMF GAIN	SETUP PARAMETERS::FIELD CONTROL::FLD.CURRENT VARS::FLD.WEAK VARS	Field Control	0.00 to 100.00	0.30	ex	
176	RW	EMF LAG	SETUP PARAMETERS::FIELD CONTROL::FLD.CURRENT VARS::FLD.WEAK VARS	Field Control	0.00 to 200.00	40.00	ew	
175	RW	EMF LEAD	SETUP PARAMETERS::FIELD CONTROL::FLD.CURRENT VARS::FLD.WEAK VARS	Field Control	0.10 to 50.00	2.00	ev	
174	RW	FLD. WEAK ENABLE	SETUP PARAMETERS::FIELD CONTROL::FLD.CURRENT VARS::FLD.WEAK VARS	Field Control	0 : Disabled 1 : Enabled	Disabled	eu	2
178	RW	MAX VOLTS	SETUP PARAMETERS::FIELD CONTROL::FLD.CURRENT VARS::FLD.WEAK VARS	Field Control	0.00 to 100.00 %	100.00%	ey	
179	RW	MIN FLD.CURRENT	SETUP PARAMETERS::FIELD CONTROL::FLD.CURRENT VARS::FLD.WEAK VARS	Field Control	0.00 to 100.00 %	10.00%	ez	2
203	RO	Inverse Time O/P	DIAGNOSTICS	Inverse Time	xxx.xx %	200.0%	fn	Output, 2, 4
204	RW	Aiming Point	SETUP PARAMETERS::INVERSE TIME	Inverse Time	0.00 to 103.00 %	103.00%	fo	2, 4
199	RW	Delay	SETUP PARAMETERS::INVERSE TIME	Inverse Time	0.1 to 600.0 Secs	10.0 Secs	fj	2, 4
200	RW	Rate	SETUP PARAMETERS::INVERSE TIME	Inverse Time	0.1 to 600.0 Secs	60.0 Secs	fk	2, 4
212	RO	Operating Mode	DIAGNOSTICS	Jog/Slack	0 : Stop 1 : Stop 2 : Jog Sp. 1 3 : Jog Sp. 2 4 : Run 5 : Take Up Sp. 1 6 : Take Up Sp. 2 7 : Crawl	Stop	fw	Output

Table B-4 Parameters Listed by WB Block Continued

Tag	R/W	Name	Keypad Menu	WB Block	Range	Factory Setting	MN	Notes
225	RW	Crawl Speed	SETUP PARAMETERS::JOG/SLACK	Jog/Slack	-100.00 to 100.00 %	10.00%	g9	
218	RW	Jog Speed 1	SETUP PARAMETERS::JOG/SLACK	Jog/Slack	-100.00 to 100.00 %	20.00 %	g2	
219	RW	Jog Speed 2	SETUP PARAMETERS::JOG/SLACK	Jog/Slack	-100.00 to 100.00 %	-5.00 %	g3	
228	RW	Mode	SETUP PARAMETERS::JOG/SLACK	Jog/Slack	0 : False 1 : True	FALSE	gc	
355	RW	Ramp Rate	SETUP PARAMETERS::JOG/SLACK	Jog/Slack	0.1 to 600.0 Secs	1.0 Secs	gv	
253	RW	Take Up 1	SETUP PARAMETERS::JOG/SLACK	Jog/Slack	-100.00 to 100.00 %	5.00%	h1	
254	RW	Take Up 2	SETUP PARAMETERS::JOG/SLACK	Jog/Slack	-100.00 to 100.00 %	-5.00%	h2	
365	RW	Destination Tag	SYSTEM::CONFIGURE I/O::INTERNAL LINKS::LINK 1	Link 1	0 to 549	0	k5	2, 3
364	RW	Source Tag	SYSTEM::CONFIGURE I/O::INTERNAL LINKS::LINK 1	Link 1	0 to 549	0	k4	2, 3
470	RW	Destination Tag	SYSTEM::CONFIGURE I/O::INTERNAL LINKS::LINK 10	Link 10	0 to 549	0	n2	2, 3
469	RW	Source Tag	SYSTEM::CONFIGURE I/O::INTERNAL LINKS::LINK 10	Link 10	0 to 549	0	n1	2, 3
367	RW	Destination Tag	SYSTEM::CONFIGURE I/O::INTERNAL LINKS::LINK 2	Link 2	0 to 549	0	k7	2, 3
366	RW	Source Tag	SYSTEM::CONFIGURE I/O::INTERNAL LINKS::LINK 2	Link 2	0 to 549	0	k6	2, 3
369	RW	Destination Tag	SYSTEM::CONFIGURE I/O::INTERNAL LINKS::LINK 3	Link 3	0 to 549	0	k9	2, 3
368	RW	Source Tag	SYSTEM::CONFIGURE I/O::INTERNAL LINKS::LINK 3	Link 3	0 to 549	0	k8	2, 3
371	RW	Destination Tag	SYSTEM::CONFIGURE I/O::INTERNAL LINKS::LINK 4	Link 4	0 to 549	0	kb	2, 3
370	RW	Source Tag	SYSTEM::CONFIGURE I/O::INTERNAL LINKS::LINK 4	Link 4	0 to 549	0	ka	2, 3
455	RW	Destination Tag	SYSTEM::CONFIGURE I/O::INTERNAL LINKS::LINK 5	Link 5	0 to 549	0	mn	2, 3
454	RW	Source Tag	SYSTEM::CONFIGURE I/O::INTERNAL LINKS::LINK 5	Link 5	0 to 549	0	m m	2, 3
457	RW	Destination Tag	SYSTEM::CONFIGURE I/O::INTERNAL LINKS::LINK 6	Link 6	0 to 549	0	mp	2, 3
456	RW	Source Tag	SYSTEM::CONFIGURE I/O::INTERNAL LINKS::LINK 6	Link 6	0 to 549	0	mo	2, 3
459	RW	Destination Tag	SYSTEM::CONFIGURE I/O::INTERNAL LINKS::LINK 7	Link 7	0 to 549	0	mr	2, 3
458	RW	Source Tag	SYSTEM::CONFIGURE I/O::INTERNAL LINKS::LINK 7	Link 7	0 to 549	0	mq	2, 3
461	RW	Destination Tag	SYSTEM::CONFIGURE I/O::INTERNAL LINKS::LINK 8	Link 8	0 to 549	0	mt	2, 3
460	RW	Source Tag	SYSTEM::CONFIGURE I/O::INTERNAL LINKS::LINK 8	Link 8	0 to 549	0	ms	2, 3
468	RW	Destination Tag	SYSTEM::CONFIGURE I/O::INTERNAL LINKS::LINK 9	Link 9	0 to 549	0	n0	2, 3
467	RW	Source Tag	SYSTEM::CONFIGURE I/O::INTERNAL LINKS::LINK 9	Link 9	0 to 549	0	mz	2, 3
37	RW	FULL MENUS	MENUS	Menus	0 : Disabled 1 : Enabled	Enabled	b1	
547	RW	SPD.FBK.FILTER	SETUP PARAMETERS::SPEED LOOP	Menus	0.000 to 1.000	0.000	p7	
514	RW	Ramp Accel Time	SETUP PARAMETERS::OP STATION::LOCAL RAMP	Op Station	0.1 to 600.0 Secs	10.0 Secs	oa	
515	RW	Ramp Decel Time	SETUP PARAMETERS::OP STATION::LOCAL RAMP	Op Station	0.1 to 600.0 Secs	10.0 Secs	ob	
513	RW	Jog Setpoint	SETUP PARAMETERS::OP STATION::SET UP	Op Station	0.00 to 100.00 %	5.00%	o9	1
511	RW	Local Key Enable	SETUP PARAMETERS::OP STATION::SET UP	Op Station	0 : False 1 : True	TRUE	o7	
512	RW	Setpoint	SETUP PARAMETERS::OP STATION::SET UP	Op Station	0.00 to 100.00 %	0.00%	o8	1
516	RW	Forward	SETUP PARAMETERS::OP STATION::START UP VALUES	Op Station	0 : False 1 : True	TRUE	oc	
520	RW	Jog Setpoint	SETUP PARAMETERS::OP STATION::START UP VALUES	Op Station	0.00 to 100.00 %	5.00%	og	

Table B-4 Parameters Listed by WB Block Continued

Tag	R/W	Name	Keypad Menu	WB Block	Range	Factory Setting	MN	Notes
517	RW	Local	SETUP PARAMETERS::OP STATION::START UP VALUES	Op Station	0 : False 1 : True	TRUE	od	
518	RW	Program	SETUP PARAMETERS::OP STATION::START UP VALUES	Op Station	0 : False 1 : True	FALSE	oe	
519	RW	Setpoint	SETUP PARAMETERS::OP STATION::START UP VALUES	Op Station	0.00 to 100.00 %	0.00%	of	
416	RO	PID Clamped	DIAGNOSTICS	PID	0 : False 1 : True	False	lk	Output
415	RO	PID Error	DIAGNOSTICS	PID	xxx.xx %	0.00%	lj	Output
417	RO	PID Output	DIAGNOSTICS	PID	xxx.xx %	0.00%	ll	Output
401	RW	DERIVATIVE TC	SETUP PARAMETERS::SPECIAL BLOCKS::PID	PID	0.000 to 10.000 Secs	0.000Secs	l5	
418	RW	Divider 1	SETUP PARAMETERS::SPECIAL BLOCKS::PID	PID	-3.0000 to 3.0000	1.0000	lm	
414	RW	Divider 2	SETUP PARAMETERS::SPECIAL BLOCKS::PID	PID	-3.0000 to 3.0000	1.0000	li	
408	RW	Enable	SETUP PARAMETERS::SPECIAL BLOCKS::PID	PID	0 : Disabled 1 : Enabled	Enabled	lc	
403	RW	FILTER T.C.	SETUP PARAMETERS::SPECIAL BLOCKS::PID	PID	0.000 to 10.000 Secs	0.100 Secs	l7	
410	RW	Input 1	SETUP PARAMETERS::SPECIAL BLOCKS::PID	PID	-300.00 to 300.00 %	0.00%	le	
411	RW	Input 2	SETUP PARAMETERS::SPECIAL BLOCKS::PID	PID	-300.00 to 300.00 %	0.00%	lf	
409	RW	INT. DEFEAT	SETUP PARAMETERS::SPECIAL BLOCKS::PID	PID	0 : Off 1 : On	Off	ld	
402	RW	INT.TIME.CONST	SETUP PARAMETERS::SPECIAL BLOCKS::PID	PID	0.01 to 100.00 Secs	5.00 Secs	l6	
474	RW	MIN PROFILE GAIN	SETUP PARAMETERS::SPECIAL BLOCKS::PID	PID	0.00 to 100.00 %	20.00%	n6	
473	RW	Mode	SETUP PARAMETERS::SPECIAL BLOCKS::PID	PID	0 to 4	0	n5	
406	RW	Negative Limit	SETUP PARAMETERS::SPECIAL BLOCKS::PID	PID	-105.00 to 0.00 %	-100.00%	la	
407	RW	O/P SCALER(TRIM)	SETUP PARAMETERS::SPECIAL BLOCKS::PID	PID	-3.0000 to 3.0000	0.2000	lb	
405	RW	Positive Limit	SETUP PARAMETERS::SPECIAL BLOCKS::PID	PID	0.00 to 105.00 %	100.00%	l9	
475	RO	Profiled Gain	SETUP PARAMETERS::SPECIAL BLOCKS::PID	PID	xxxx.x	0.0	n7	Output
404	RW	PROP. GAIN	SETUP PARAMETERS::SPECIAL BLOCKS::PID	PID	0.0 to 100.0	1.0	l8	
412	RW	Ratio 1	SETUP PARAMETERS::SPECIAL BLOCKS::PID	PID	-3.0000 to 3.0000	1.0000	lg	
413	RW	Ratio 2	SETUP PARAMETERS::SPECIAL BLOCKS::PID	PID	-3.0000 to 3.0000	1.0000	lh	
400	RW	PID O/P DEST	SYSTEM::CONFIGURE I/O::BLOCK DIAGRAM	PID Output	0 to 549	0	l4	2, 3
264	RO	Raise/Lower O/P	DIAGNOSTICS	Raise/Lower	xxx.xx %	0.00%	hc	Output
257	RW	Decrease Rate	SETUP PARAMETERS::RAISE/LOWER	Raise/Lower	0.1 to 600.0 Secs	10.0 Secs	h5	
307	RW	External Reset	SETUP PARAMETERS::RAISE/LOWER	Raise/Lower	0 : False 1 : True	FALSE	ij	
256	RW	Increase Rate	SETUP PARAMETERS::RAISE/LOWER	Raise/Lower	0.1 to 600.0 Secs	10.0 Secs	h4	
262	RW	Lower Input	SETUP PARAMETERS::RAISE/LOWER	Raise/Lower	0 : False 1 : True	FALSE	ha	
259	RW	Max Value	SETUP PARAMETERS::RAISE/LOWER	Raise/Lower	-300.00 to 300.00 %	100.00%	h7	
258	RW	Min Value	SETUP PARAMETERS::RAISE/LOWER	Raise/Lower	-300.00 to 300.00 %	-100.00%	h6	
261	RW	Raise Input	SETUP PARAMETERS::RAISE/LOWER	Raise/Lower	0 : False 1 : True	FALSE	h9	
255	RW	Reset Value	SETUP PARAMETERS::RAISE/LOWER	Raise/Lower	-300.00 to 300.00 %	0.00%	h3	
260	RW	Raise/Lower Dest	SYSTEM::CONFIGURE I/O::BLOCK DIAGRAM	Raise/Lower Output	0 to 549	0	h8	
293	RW	RAMP O/P DEST	SYSTEM::CONFIGURE I/O::BLOCK DIAGRAM	Ramp Output	0 to 549	291	i5	2, 3
85	RO	Ramp Output	DIAGNOSTICS	Ramps	xxx.xx %	0.00%	cd	Output
113	RO	Ramping	DIAGNOSTICS	Ramps	0 : False 1 : True	False	d5	Output
266	RW	% S-RAMP	SETUP PARAMETERS::RAMPS	Ramps	0.00 to 100.00 %	2.50%	he	
287	RW	Auto Reset	SETUP PARAMETERS::RAMPS	Ramps	0 : Disabled 1 : Enabled	Enabled	hz	
4	RW	Constant Accel	SETUP PARAMETERS::RAMPS	Ramps	0 : Disabled 1 : Enabled	Enabled	a4	
288	RW	External Reset	SETUP PARAMETERS::RAMPS	Ramps	0 : Disabled 1 : Enabled	Disabled	i0	
620	RW	Invert	SETUP PARAMETERS::RAMPS	Ramps	0 : False 1 : True	False		
126	RW	MIN SPEED	SETUP PARAMETERS::RAMPS	Ramps	0.00 to 100.00 %	0.00%	di	
2	RW	Ramp Accel Time	SETUP PARAMETERS::RAMPS	Ramps	0.1 to 600.0 Secs	10.0 Secs	a2	
3	RW	Ramp Decel Time	SETUP PARAMETERS::RAMPS	Ramps	0.1 to 600.0 Secs	10.0 Secs	a3	
118	RW	Ramp Hold	SETUP PARAMETERS::RAMPS	Ramps	0 : Off 1 : On	Off	da	
5	RW	Ramp Input	SETUP PARAMETERS::RAMPS	Ramps	-105.00 to 105.00 %	0.00%	a5	
286	RW	RAMPING THRESH.	SETUP PARAMETERS::RAMPS	Ramps	0.00 to 100.00 %	0.50%	hy	
422	RW	Reset Value	SETUP PARAMETERS::RAMPS	Ramps	-300.00 to 300.00 %	0.00%	lq	
135	RW	Destination Tag	SYSTEM::CONFIGURE I/O::CONFIGURE 5703	Scaled 5703 Input	0 to 549	41	dr	2, 3
86	RO	SPT SUM OUTPUT	DIAGNOSTICS	Setpoint Sum 1	xxx.xx %	0.00%	ce	Output
131	RW	Deadband Width	SETUP PARAMETERS::SETPOINT SUM 1	Setpoint Sum 1	0.00 to 100.00 % (h)	0.0%	dn	
420	RW	Divider 0	SETUP PARAMETERS::SETPOINT SUM 1	Setpoint Sum 1	-3.0000 to 3.0000	1.0000	lo	
419	RW	Divider 1	SETUP PARAMETERS::SETPOINT SUM 1	Setpoint Sum 1	-3.0000 to 3.0000	1.0000	ln	
309	RW	Input 0	SETUP PARAMETERS::SETPOINT SUM 1	Setpoint Sum 1	-200.00 to 200.00 %	0.00%	il	

Table B-4 Parameters Listed by WB Block Continued

Tag	R/W	Name	Keypad Menu	WB Block	Range	Factory Setting	MN	Notes
100	RW	Input 1	SETUP PARAMETERS::SETPOINT SUM 1	Setpoint Sum 1	-200.00 to 200.00 %	0.00%	cs	
423	RW	Input 2	SETUP PARAMETERS::SETPOINT SUM 1	Setpoint Sum 1	-200.00 to 200.00 %	0.00%	lr	
375	RW	Limit	SETUP PARAMETERS::SETPOINT SUM 1	Setpoint Sum 1	0.00 to 200.00 %	105.00%	kf	
208	RW	Ratio 0	SETUP PARAMETERS::SETPOINT SUM 1	Setpoint Sum 1	-3.0000 to 3.0000	1.0000	fs	
6	RW	Ratio 1	SETUP PARAMETERS::SETPOINT SUM 1	Setpoint Sum 1	-3.0000 to 3.0000	1.0000	a6	
292	RW	SIGN 0	SETUP PARAMETERS::SETPOINT SUM 1	Setpoint Sum 1	0 : Negative 1 : Positive	Positive	i4	
8	RW	Sign 1	SETUP PARAMETERS::SETPOINT SUM 1	Setpoint Sum 1	0 : Negative 1 : Positive	Positive	a8	
294	RW	SPT SUM 1 DEST	SYSTEM::CONFIGURE I/O::BLOCK DIAGRAM	Setpoint Sum 1 Output	0 to 549	289	i6	2, 3
49	RW	ENCODER SIGN	CONFIGURE DRIVE	Speed Loop	0 : Negative 1 : Positive	Positive	bd	2
13	RW	SPD.INT.TIME	CONFIGURE DRIVE	Speed Loop	0.001 to 30.000 Secs	0.500 Secs	ad	
14	RW	SPD.PROP.GAIN	CONFIGURE DRIVE	Speed Loop	0.00 to 200.00	10	ae	
47	RW	SPEED FBK SELECT	CONFIGURE DRIVE	Speed Loop	0 : Arm Volts Fbk 1 : Analog Tach 2 : Encoder 3 : Encoder/Analog	Arm Volts Fbk	bb 2	
549	RO	Speed LOOP O/P	DIAGNOSTICS	Speed Loop	-200 to 200 %	0.00%	p9	Output, 2
63	RO	Speed Setpoint	DIAGNOSTICS	Speed Loop	xxx.xx %	0.00%	br	Output
64	RO	UNFIL.SPD.ERROR	DIAGNOSTICS	Speed Loop	xxx.xx %	0.00%	bs	Output
62	RO	UNFIL.SPD.FBK	DIAGNOSTICS	Speed Loop	xxx.xx %	0.03%	bq	Output
202	RW	INT. DEFEAT	SETUP PARAMETERS::SPEED LOOP	Speed Loop	0 : Off 1 : On	Off	fm	
357	RW	Max Demand	SETUP PARAMETERS::SPEED LOOP::SET-POINTS	Speed Loop	0.00 to 105.00 %	105.00%	jx	
358	RW	Min Demand	SETUP PARAMETERS::SPEED LOOP::SET-POINTS	Speed Loop	-105.00 to 105.00 %	-105.00%	jy	
7	RW	Ratio 2 (A3)	SETUP PARAMETERS::SPEED LOOP::SET-POINTS	Speed Loop	-3.0000 to 3.0000	.0000	a7	
289	RW	Setpoint 1	SETUP PARAMETERS::SPEED LOOP::SET-POINTS	Speed Loop	-105.00 to 105.00 %	0.00%	i1	
290	RO	Setpoint 2 (A3)	SETUP PARAMETERS::SPEED LOOP::SET-POINTS	Speed Loop	xxx.xx %	0.00%	i2	Output
291	RW	Setpoint 3	SETUP PARAMETERS::SPEED LOOP::SET-POINTS	Speed Loop	-105.00 to 105.00 %	0.00%	i3	
41	RW	Setpoint 4	SETUP PARAMETERS::SPEED LOOP::SET-POINTS	Speed Loop	-105.00 to 105.00 %	0.00%	b5	
9	RW	Sign 2 (A3)	SETUP PARAMETERS::SPEED LOOP::SET-POINTS	Speed Loop	0 : Negative 1 : Positive	Positive	a9	
79	RO	At Standstill	DIAGNOSTICS	Standstill	0 : False 1 : True	True	c7	Output
78	RO	At Zero Setpoint	DIAGNOSTICS	Standstill	0 : False 1 : True	True	c6	Output
77	RO	At Zero Speed	DIAGNOSTICS	Standstill	0 : False 1 : True	True	c5	Output
306	RW	Source Tag	SETUP PARAMETERS::STANDSTILL	Standstill	0 to 549	89	ii	2, 3, 4
11	RW	Standstill Logic	SETUP PARAMETERS::STANDSTILL	Standstill	0 : Disabled 1 : Enabled	Disabled	ab	
12	RW	Zero Threshold	SETUP PARAMETERS::STANDSTILL	Standstill	0.00 to 100.00 %	2.00%	ac	
525	RO	Coast Stop	DIAGNOSTICS	Stop Rates	0 : False 1 : True	FALSE	ol	Output
80	RO	Program Stop	DIAGNOSTICS	Stop Rates	0 : False 1 : True	False	c8	Output
89	RO	Speed Demand	DIAGNOSTICS	Stop Rates	xxx.xx %	0.00%	ch	Output
302	RW	Contactors Delay	SETUP PARAMETERS::STOP RATES	Stop Rates	0.1 to 600.0 Secs	1.0 Secs	ie	
594	RW	CURR Decay Rate	SETUP PARAMETERS::STOP RATES	Stop Rates	0 to 200.00	0.00		
91	RW	PROG STOP I LIM	SETUP PARAMETERS::STOP RATES	Stop Rates	0.00 to 200.00 %	100.00%	cj	
216	RW	PROG STOP LIMIT	SETUP PARAMETERS::STOP RATES	Stop Rates	0.0 to 600.0 Secs	60.0 Secs	g0	
26	RW	PROG Stop Time	SETUP PARAMETERS::STOP RATES	Stop Rates	0.1 to 600.0 Secs	0.1 Secs	aq	
217	RW	Stop Limit	SETUP PARAMETERS::STOP RATES	Stop Rates	0.0 to 600.0 Secs	60.0 Secs	g1	
27	RW	Stop Time	SETUP PARAMETERS::STOP RATES	Stop Rates	0.1 to 600.0 Secs	10.0 Secs	ar	
29	RW	Stop Zero Speed	SETUP PARAMETERS::STOP RATES	Stop Rates	0.00 to 100.00 %	2.00%	at	
130	RW	Mode	SERIAL LINKS::SYSTEM PORT (P3)::P3 SET-UP	System Port P3	0 : Disabled 1 : 5703 Master 2 : 5703 Slave 3 : CELite (EIASCII)	0	dm	

Table B-4 Parameters Listed by WB Block Continued

Tag	R/W	Name	Keypad Menu	WB Block	Range	Factory Setting	MN	Notes
332	RW	Error Report	SERIAL LINKS::SYSTEM PORT (P3)::P3 SET-UP::BISYNCH SUPPORT	System Port P3	0x0000 to 0xFFFF	0x00C0	j8	1
329	RW	GROUP ID (GID)	SERIAL LINKS::SYSTEM PORT (P3)::P3 SET-UP::BISYNCH SUPPORT	System Port P3	0x0000 to 0x0007	0x0000	j5	
330	RW	UNIT ID (UID)	SERIAL LINKS::SYSTEM PORT (P3)::P3 SET-UP::BISYNCH SUPPORT	System Port P3	0x0000 to 0x000F	0x0000	j6	
506	RO	TEC Option Fault	SERIAL LINKS::TEC OPTION	Tec Option	0 : None 1 : Parameter 2 : Type Mismatch 3 : Self Test 4 : Hardware 5 : Missing	None	o2	Output
501	RW	TEC Option IN 1	SERIAL LINKS::TEC OPTION	Tec Option	-32768 to 32767	0	nx	
502	RW	TEC Option IN 2	SERIAL LINKS::TEC OPTION	Tec Option	-32768 to 32767	0	ny	
503	RW	TEC Option IN 3	SERIAL LINKS::TEC OPTION	Tec Option	-32768 to 32767	0	nz	
504	RW	TEC Option IN 4	SERIAL LINKS::TEC OPTION	Tec Option	-32768 to 32767	0	o0	
505	RW	TEC Option IN 5	SERIAL LINKS::TEC OPTION	Tec Option	-32768 to 32767	0	o1	
508	RO	TEC Option OUT 1	SERIAL LINKS::TEC OPTION	Tec Option	xxxxx	0	o4	Output, 1
509	RO	TEC Option OUT 2	SERIAL LINKS::TEC OPTION	Tec Option	xxxxx	0	o5	Output, 1
500	RW	TEC Option Type	SERIAL LINKS::TEC OPTION	Tec Option	0 : None 1 : Rs485 2 : Profibus Dp 3 : Link 4 : Device Net 5 : Can Open 6 : Lonworks 7 : Type 7	None	nw	
507	RO	TEC Option VER	SERIAL LINKS::TEC OPTION	Tec Option	0x0000 to 0xFFFF	0x0000	o3	Output, 1
472	RO	SPEED FBK STATE	ALARM STATUS	Unallocated	0 : False 1 : True	False	n4	Output
337	RO	Thermistor State	ALARM STATUS	Unallocated	0 : False 1 : True	False	jd	Output
39	RW	Configure Enable	CONFIGURE DRIVE	Unallocated	0 : Disabled 1 : Enabled	Disabled	b3	2
605	RO	ARM Volts FBK	DIAGNOSTICS	Unallocated		0 Volts		Output
83	RO	Contactorm Closed	DIAGNOSTICS	Unallocated	0 : Off 1 : On	Off	cb	Output
376	RO	Drive Running	DIAGNOSTICS	Unallocated	0 : False 1 : True	False	kg	Output
374	RO	System Reset	DIAGNOSTICS	Unallocated	0 : False 1 : True	True	ke	Output
354	RW	Parameter Save	PARAMETER SAVE	Unallocated	Up To Action Requested		ju	1
155	RO	Version Number	SERIAL LINKS::SYSTEM PORT (P3)	Unallocated	0x0000 to 0xFFFF		eb	Output

Appendix C Block Diagram

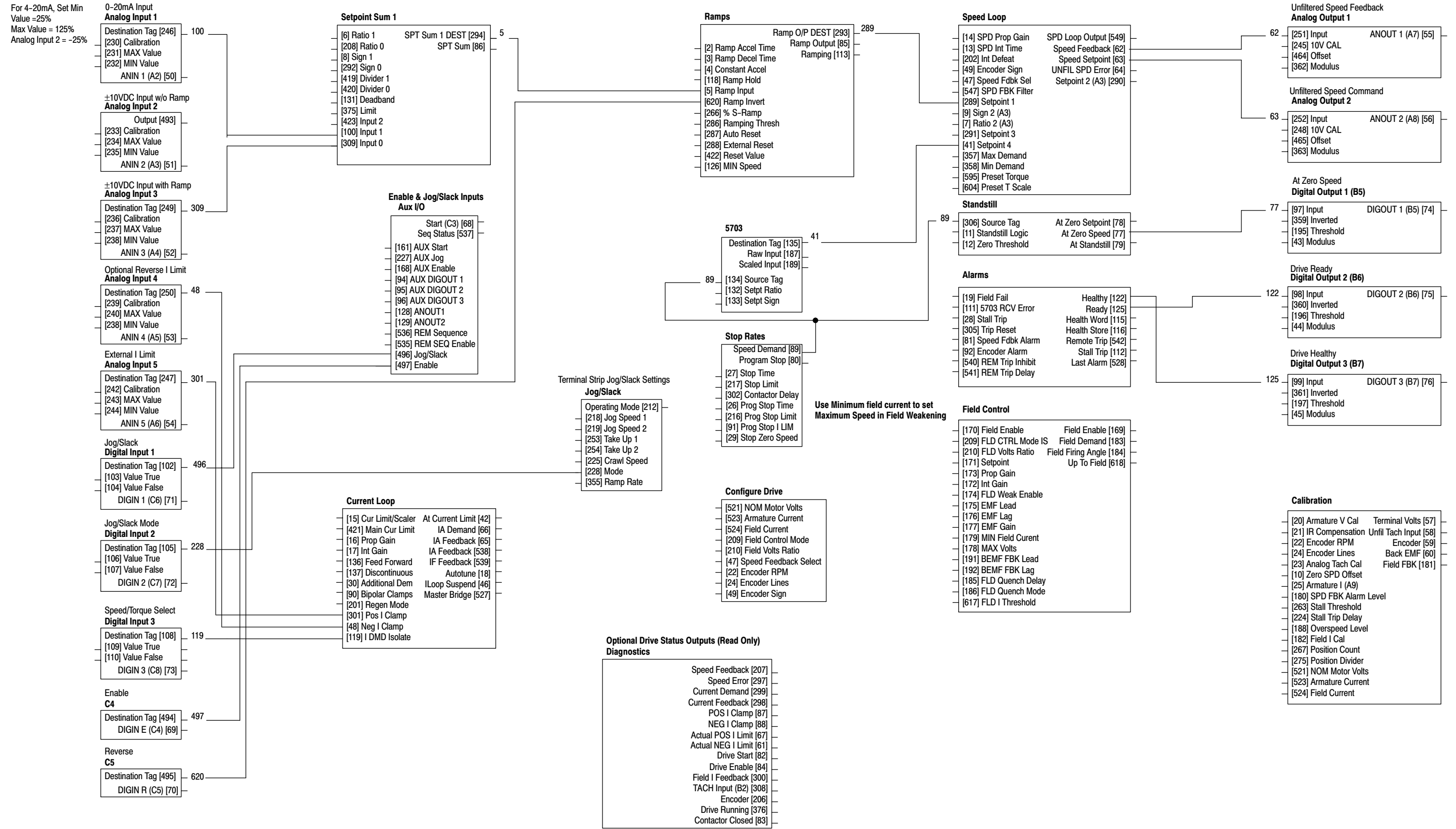

Baldor Series 30D Digital DC Drive

OP Station (Keypad)

[511] Local Key Enable	Error Report [158]
[512] Setpoint	
[513] Jog Setpoint	
[514] Ramp Accel Time	
[515] Ramp Decel Time	
[516] Inital FWD Direction	
[517] Initial Local	
[518] Initial Program	
[519] Initial Setpoint	
[520] Inital Jog Setpoint	

PID

[404] PROP Gain	PID O/P DEST [400]
[402] INT Time Const	PID Output [417]
[401] Derivative TC	PID Clamped [416]
[405] Positive Limit	PID Error [415]
[406] Negative Limit	Profiled Gain [475]
[407] Output Scaler (Trim)	
[410] Input 1	
[411] Input 2	
[412] Ratio 1	
[413] Ratio 2	
[418] Divider 1	
[414] Divider 2	
[408] Enable	
[409] Int Defeat	
[403] Filter TC	
[473] Mode	
[474] MIN Profile Gain	

Raise/Lower

[255] Reset Value	Raise/Lower DEST [260]
[256] Increase Rate	Raise/Lower O/P [264]
[257] Decrease Rate	
[261] Raise Input	
[262] Lower Input	
[258] MIN Value	
[259] MAX Value	
[307] External Reset	

Menus

[37] Full Menus
[547] Speed FDBK Filter
[304] Language

Advanced

[268] Mode
[269] Speed BRK 1 (Low)
[270] Speed BRK 2 (High)
[271] PROP Gain
[272] INT Time Const
[274] I Gain In Ramp
[273] POS Loop P Gain
[284] Zero Speed Level
[285] Zero IAD Level

TEC Option

[500] Type	Fault [506]
[501] Input 1	Version [507]
[502] Input 2	Output 1 [508]
[503] Input 3	Output 2 [509]
[504] Input 4	
[505] Input 5	

Current Profile

[32] SPD BRK 1 (Low)
[31] SPD BRK 2 (High)
[93] IMAX BRK 1 (SPD1)
[33] IMAX BRK 2 (SPD2)

miniLINK

[339] Value 1	0	PNO 112
[340] Value 2	0	PNO 113
[341] Value 3	0	PNO 114
[342] Value 4	0	PNO 115
[343] Value 5	0	PNO 116
[344] Value 6	0	PNO 117
[345] Value 7	0	PNO 118
[379] Value 8	379	PNO 119
[380] Value 9	380	PNO 120
[381] Value 10	381	PNO 121
[382] Value 11	382	PNO 122
[383] Value 12	383	PNO 123
[384] Value 13	384	PNO 124
[385] Value 14	385	PNO 125
[346] Logic 1	0	PNO 126
[347] Logic 2		PNO 127
[348] Logic 3		
[349] Logic 4		
[350] Logic 5		
[351] Logic 6		
[352] Logic 7		
[353] Logic 8		

System Port P3

[332] Error Report
[130] Mode
[329] Group ID
[330] Init ID

BALDOR®

BALDOR ELECTRIC COMPANY
P.O. Box 2400
Ft. Smith, AR 72902-2400
(479) 646-4711
Fax (479) 648-5792
www.baldor.com

CH TEL: +41 52 647 4700 FAX: +41 52 659 2394	D TEL: +49 89 90 50 80 FAX: +49 89 90 50 8491	UK TEL: +44 1454 850000 FAX: +44 1454 859001	F TEL: +33 145 10 7902 FAX: +33 145 09 0864
I TEL: +39 11 562 4440 FAX: +39 11 562 5660	AU TEL: +61 29674 5455 FAX: +61 29674 2495	CC TEL: +65 744 2572 FAX: +65 747 1708	MX TEL: +52 477 761 2030 FAX: +52 477 761 2010



* 7 9 3 - 9 0 3 *

МН793

Series 30 Digital DC Control

MN793