



Document Reference: AN060005VS1

Title: Profile Run



Required Equipment:

**VS1SP Inverter
VS1GV Vector
VS1SD Servo**

Introduction:

Profile run mode allows the user to configure the drive to follow up to 7 different preset speed profiles. Profile refers to the time the motor will be turning at a specific rpm/Hz. For example: Profile 1 is set at 20 rpm/Hz, Profile 2 is set at 60 rpm/Hz. The drive will control these two profiles in a continuous or timed loop.

Procedure:

1. From the BALDOR VS1 keypad.
2. Select **MAIN**
3. Use the Arrow keys  to scroll through the menus, press the  **ENTER** key for changes //save.
4. Select **PROGRAMMING**
5. ENTER >**Level 1 Blocks** >**Input Setup** >**Operating Mode (P#1401)** >**Profile Run (#12)**.
6. ENTER >**Level 3 Blocks**>**PROFILE RUN** >Select **NUMBER OF CYCLES-0-255**.
7. ENTER > **PR RESTART MODE** > Continue or Restart (see Installation

Manual for details).

8. Select > **SPEED CURVES 1-7 > Forward-Group 1-2 or Reverse-Group 1-2**
(FWD//REV).
9. Select >**PROFILE TIME 1-7** (0-65535.00 seconds).
10. Select >**Level 1 Blocks PRESET SPEEDS > PRESET SPEED 1-7**. Set
required profile speeds.
11. **Group 2** speed curves can be set by programming >**Level 1 Blocks >RAMP**
RATES > ACCEL // DECEL TIME 2, (P# 1107, 1110).
12. Remove factory jumper wire terminal 8-24 and install remote switches or contacts
before starting. See *Figure 1 for connection diagram.

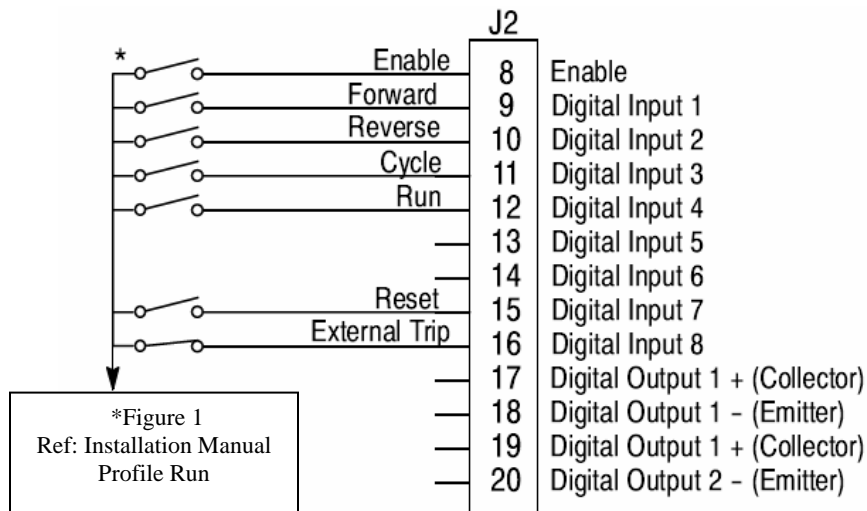

- J2-8 Closed allows normal operation.
Open disables the control and motor coasts to a stop.
- J2-9 Closed to maintain operation in the Forward direction.
Open to disable Forward operation (drive will decel to a stop if a Forward command is still present).
- J2-10 Closed to maintain operation in the Reverse direction.
Open to disable Reverse operation (drive will decel to a stop if a Reverse command is still present).
- J2-11 Closed runs the profile for an indefinite number of cycles. When the Level 3, Profile Run, Number of Cycles (P#3001) cycle count is reached, the counter is reset and the mode restarts (continuous cycling).
- J2-12 Closed uses Run Command from J2-9 or J2-10.
Open uses Run Command from Keypad.
- J2-15 Closed resets an alarm or fault.

J2-16 Optional External Trip input (not required).

Note: **In order for the drive to auto restart from power up: Enter>Level 2 Blocks>
MISCELLANEOUS>AUTO RESTART> At Power up (P# 2301).