

# TIMING PULLEY



## DID YOU KNOW THAT...

- All parts are completely machined in cast iron; some parts made from steel
- Synchronized no-slip transmission
- No lubrication required
- Compact design, high efficiency
- Low maintenance, economical operations

## IMPORTANT REMINDER



**Maska double taper-style timing pulleys are no longer being manufactured. They will be gradually replaced by the more conventional single taper model (equivalent compatible products).**

## HOW TO ORDER

EXAMPLE: **P30H300-2012 PB**

**P30**

**H**

**300**

**2012**

**PB**

**P30:** NUMBER OF TEETH (30)

**H:** TOOTH PITCH (1/2")

**300:** TIMING BELT WIDTH (3.00")

**2012:** HUB SIZE RELATES TO THE TAPER LOCK BUSHING.

**PB:** INDICATES AVAILABLE IN PLAIN BORE

1. All Charts: The type of sheave construction is indicated in the column entitled « T ». The number refers to the drawing and the letter as follows: A = arms; B = block; W = web; F = flanges

2. All dimensions are to the closest fraction.

3. Weight for all items is approximate.

## XL PITCH

### DIMENSIONS

SYNCHRONOUS DRIVES

Part No	List Price \$	Bushing	Number of Teeth	Diameters			Type	Dimensions (inches)				Bore Range		Wt	
				Pitch Diam.	O.D. Sprocket	O.D. Flange		I.D.	K	M	N	H	Min.		Max.
<b>For Belts 1/4", 5/16" &amp; 3/8" wide - 1/5" pitch (XL037) - Face width (F) = 9/16"</b>															
P10XL037-PB	9.00	...	10	0.637	0.617	0.91	...	3B F	1/4	...	...	1/2	3/16	1/4*	0.05
P11XL037-PB	9.40	...	11	0.700	0.680	0.91	...	3B F	1/4	...	...	1/2	3/16	1/4*	0.05
P12XL037-PB	9.80	...	12	0.764	0.744	0.98	...	3B F	1/4	...	...	1/2	3/16	5/16*	0.07
P14XL037-PB	11.70	...	14	0.891	0.871	1.10	...	3B F	1/4	...	...	9/16	1/4	3/8*	0.09
P15XL037-PB	12.10	...	15	0.955	0.935	1.10	...	3B F	1/4	...	...	5/8	1/4	7/16*	0.10
P16XL037-PB	12.80	...	16	1.019	0.999	1.26	...	3B F	1/4	...	...	11/16	1/4	1/2*	0.12
P18XL037-PB	14.30	...	18	1.146	1.126	1.38	...	3B F	1/4	...	...	13/16	1/4	9/16*	0.16
P20XL037-PB	15.10	...	20	1.273	1.253	1.50	...	3B F	11/32	...	...	15/16	1/4	11/16*	0.21
P21XL037-PB	16.20	...	21	1.337	1.317	1.50	...	3B F	11/32	...	...	15/16	1/4	11/16*	0.23
P22XL037-PB	16.60	...	22	1.401	1.381	1.61	...	3B F	11/32	...	...	1	1/4	3/4*	0.26
P24XL037-PB	18.50	...	24	1.528	1.508	1.73	...	3B F	11/32	...	...	1 1/16	1/4	13/16*	0.31
P28XL037-PB	21.10	...	28	1.783	1.763	2.01	...	3B F	11/32	...	...	1 3/16	1/4	15/16*	0.42
P30XL037-PB	22.20	...	30	1.910	1.890	2.13	...	3B F	11/32	...	...	1 3/8	5/16	1 1/16*	0.41
P32XL037-PB	22.60	...	32	2.037	2.017	...	...	3B	7/16	...	...	1 1/2	5/16	1 3/16*	0.63
P36XL037-PB	23.00	...	36	2.292	2.272	...	...	3B	7/16	...	...	1 1/2	5/16	1 3/16*	0.74
P40XL037-PB	23.40	...	40	2.546	2.526	...	...	3B	7/16	...	...	1 1/2	5/16	1 3/16*	0.88
P42XL037-PB	23.80	...	42	2.674	2.654	...	...	3B	7/16	...	...	1 1/2	5/16	1 3/16*	0.96
P44XL037-PB	24.50	...	44	2.801	2.781	...	...	3B	7/16	...	...	1 1/2	5/16	1 3/16*	1.03
P48XL037-PB	26.00	...	48	3.056	3.036	...	...	3B	7/16	...	...	1 1/2	5/16	1 3/16*	1.20
P60XL037-PB	31.30	...	60	3.820	3.800	...	...	3B	7/16	...	...	1 1/2	3/8	1 3/16*	1.78
P72XL037-PB	39.20	...	72	4.584	4.564	...	...	3B	7/16	...	...	1 1/2	3/8	1 3/16*	2.51
**P32XL037-1108	27.50	1108	32	2.037	2.017	...	...	2B	0	25/32	...	...	1/2	1 1/8	0.25
**P36XL037-1108	28.40	1108	36	2.292	2.272	...	...	2B	0	25/32	...	...	1/2	1 1/8	0.38
P40XL037-1108	29.50	1108	40	2.546	2.526	...	...	2B	7/32	25/32	...	2 5/32	1/2	1 1/8	0.57
P42XL037-1108	31.10	1108	42	2.674	2.654	...	...	2B	7/32	25/32	...	2 17/64	1/2	1 1/8	0.67
P44XL037-1108	32.50	1108	44	2.801	2.781	...	...	2B	7/32	25/32	...	2 11/32	1/2	1 1/8	0.77
P48XL037-1108	35.90	1108	48	3.056	3.036	...	...	2B	7/32	25/32	...	2 19/32	1/2	1 1/8	0.99
P60XL037-1210	37.50	1210	60	3.820	3.800	...	...	2B	7/16	63/64	...	3 13/32	1/2	1 1/4	2.02
P72XL037-1610	39.10	1610	72	4.584	4.564	...	...	2B	7/16	63/64	...	4	1/2	1 11/16	2.86

\*Available from stock in min. plain bore. Max. bore is w/o keyway. (If keyway is used, reduce max. bore listed by twice the keyway depth.) (Two hex-socket set screws furnished @ 90 degrees are included in price of pulley.)

\*\*These parts are made of steel

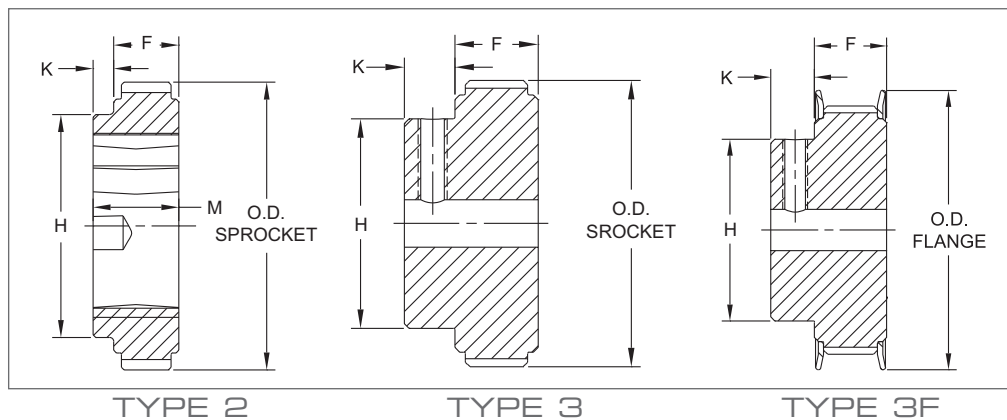

## L PITCH

Warehouse Innovation

Color-coded product labels for easy stock retrieval on shelves

**NOTE: these products are color-coded YELLOW**

### DIMENSIONS

Part No	List Price \$	Bushing	Number of Teeth	Diameters			I.D.	Type	Dimensions (inches)				Bore Range		Wt
				Pitch Diam.	O.D. Sprocket	O.D. Flange			K	M	N	H	Min.	Max.	
<b>For belts 1/2" wide - 3/8" pitch (L050) - Face Width (F) = 3/4"</b>															
P10L050-PB	14.60	...	10	1.194	1.164	1.46	...	3B F	1/2	...	...	7/8	3/8	*1/2	0.20
P12L050-PB	16.10	...	12	1.432	1.402	1.69	...	3B F	1/2	...	...	1 1/8	3/8	*3/4	0.34
P13L050-PB	17.00	...	13	1.552	1.522	1.73	...	3B F	1/2	...	...	1 7/32	3/8	*3/4	0.42
P14L050-PB	18.80	...	14	1.671	1.641	1.89	...	3B F	1/2	...	...	1 5/16	3/8	*7/8	0.48
P15L050-PB	19.20	...	15	1.790	1.760	2.01	...	3B F	1/2	...	...	1 3/8	1/2	*7/8	0.53
P16L050-PB	20.60	...	16	1.910	1.880	2.13	...	3B F	1/2	...	...	1 1/2	1/2	*1	0.62
P17L050-PB	21.80	...	17	2.029	1.999	2.24	...	3B F	1/2	...	...	1 1/2	1/2	*1	0.70
P18L050-1108	27.50	1108	18	2.149	2.119	2.38	...	2B F	1/32	25/32	...	1 49/64	1/2	1 1/8	0.40
P20L050-1108	28.40	1108	20	2.387	2.357	2.64	...	2B F	1/32	25/32	...	2	1/2	1 1/8	0.55
P21L050-1108	29.10	1108	21	2.507	2.477	2.76	...	2B F	1/32	25/32	...	1 31/32	1/2	1 1/8	0.65
P22L050-1108	29.50	1108	22	2.626	2.596	2.95	...	2B F	1/32	25/32	...	2 11/64	1/2	1 1/8	0.75
**P24L050-1210	31.10	1210	24	2.865	2.835	3.13	...	2B F	15/64	63/64	...	2 9/32	1/2	1 1/4	0.90
P26L050-1210	32.50	1210	26	3.104	3.074	3.40	...	2B F	15/64	63/64	...	2 9/16	1/2	1 1/4	1.10
P28L050-1210	34.80	1210	28	3.342	3.312	3.59	...	2B F	15/64	63/64	...	2 9/16	1/2	1 1/4	1.30
**P30L050-1610	35.00	1610	30	3.581	3.551	3.83	...	2B F	15/64	63/64	...	2 3/4	1/2	1 11/16	1.40
P32L050-1610	53.90	1610	32	3.820	3.790	4.04	...	2B F	15/64	63/64	...	2 29/32	1/2	1 11/16	1.65
P40L050-2012	58.50	2012	40	4.775	4.745	5.05	...	2B F	7/16	1 3/16	...	3 13/16	1/2	2 1/8	3.00
P48L050-2012	68.60	2012	48	5.730	5.700	5.91	...	2B F	7/16	1 3/16	...	3 15/16	1/2	2 1/8	4.55
P60L050-2012	75.80	2012	60	7.162	7.132	...	...	2W	7/16	1 3/16	...	4 11/64	1/2	2 1/8	6.15
P72L050-2012	81.50	2012	72	8.594	8.564	...	...	2W	7/16	1 3/16	...	4 11/64	1/2	2 1/8	9.55
P84L050-2517	93.70	2517	84	10.027	9.997	...	...	2W	1 1/64	1 49/64	...	4 11/16	1/2	2 11/16	13.75

\*Available from stock in min. plain bore only. Max. bore is without keyway. (If keyway is used, reduce max. bore listed by twice the keyway depth.)

\*\*These parts are made of steel

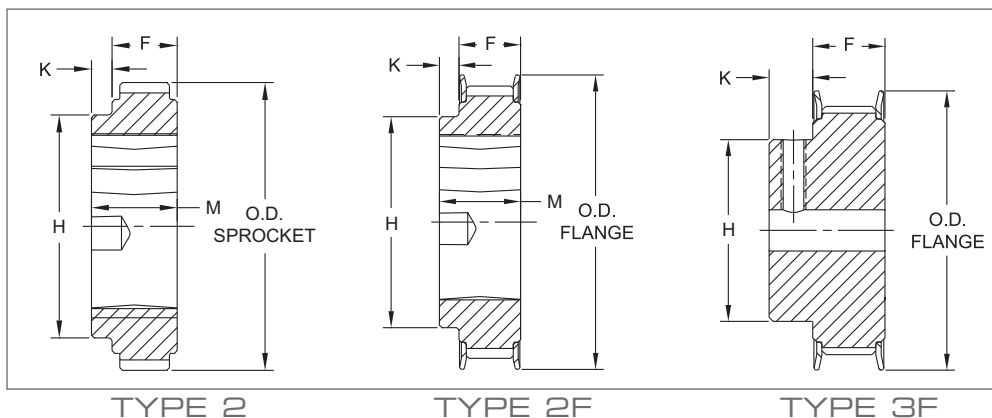

SYNCHRONOUS DRIVES

## L PITCH

Warehouse Innovation

Color-coded product labels for easy stock retrieval on shelves

**NOTE:** these products are color-coded **YELLOW**

### DIMENSIONS

Part No	List Price \$	Bushing	Number of Teeth	Diameters			I.D.	Type	Dimensions (inches)				Bore Range		Wt
				Pitch Diam.	O.D. Sprocket	O.D. Flange			K	M	N	H	Min.	Max.	
<b>For Belts 3/4" wide - 3/8" pitch (L075) - Face width (F) = 1"</b>															
P12L075-PB	19.50	...	12	1.432	1.402	1.69	...	3B F	1/2	...	...	1 1/8	3/8	*3/4	0.43
P13L075-PB	19.90	...	13	1.552	1.522	1.73	...	3B F	1/2	...	...	1 7/32	3/8	*3/4	0.50
P14L075-PB	21.30	...	14	1.671	1.641	1.89	...	3B F	1/2	...	...	1 5/16	3/8	*7/8	0.53
P15L075-PB	22.00	...	15	1.790	1.760	2.01	...	3B F	1/2	...	...	1 3/8	1/2	*7/8	0.60
P16L075-PB	22.80	...	16	1.910	1.880	2.13	...	3B F	1/2	...	...	1 1/2	1/2	*1	0.70
P17L075-PB	24.00	...	17	2.029	1.999	2.24	...	3B F	1/2	...	...	1 1/2	1/2	*1	0.80
P18L075-1108	29.10	1108	18	2.149	2.119	2.38	1.60	1B F	13/64	25/32	0	...	1/2	1 1/8	0.45
P20L075-1108	30.50	1108	20	2.387	2.357	2.64	1.77	1B F	13/64	25/32	0	...	1/2	1 1/8	0.65
P22L075-1108	33.20	1108	22	2.626	2.596	2.95	1.89	1B F	13/64	25/32	0	...	1/2	1 1/8	0.90
P24L075-1210	34.80	1210	24	2.865	2.835	3.13	...	2B F	0	63/64	...	...	1/2	1 1/4	0.90
P26L075-1210	36.80	1210	26	3.104	3.074	3.40	...	2B F	0	63/64	...	...	1/2	1 1/4	1.25
P28L075-1610	39.50	1610	28	3.342	3.312	3.59	...	2B F	0	63/64	...	...	1/2	1 11/16	1.20
P30L075-1610	42.50	1610	30	3.581	3.551	3.83	...	2B F	0	63/64	...	...	1/2	1 11/16	1.85
P32L075-1610	45.20	1610	32	3.820	3.790	4.04	...	2B F	0	63/64	...	...	1/2	1 11/16	1.85
P40L075-2012	62.50	2012	40	4.775	4.745	5.05	...	2B F	13/64	1 3/16	...	3 13/16	1/2	2 1/8	3.30
P48L075-2012	71.70	2012	48	5.730	5.700	5.91	...	2B F	13/64	1 3/16	...	3 15/16	1/2	2 1/8	5.35
P60L075-2012	82.20	2012	60	7.162	7.132	...	...	2W	13/64	1 3/16	...	4 11/64	1/2	2 1/8	6.45
P72L075-2012	89.20	2012	72	8.594	8.564	...	...	2W	13/64	1 3/16	...	4 11/64	1/2	2 1/8	9.70
P84L075-2517	109.60	2517	84	10.027	9.997	...	...	2W	25/32	1 49/64	...	4 11/16	1/2	2 11/16	14.55

\*Available from stock in min. plain bore only. Max. bore is without keyway. (If keyway is used, reduce max. bore listed by twice the keyway depth.)

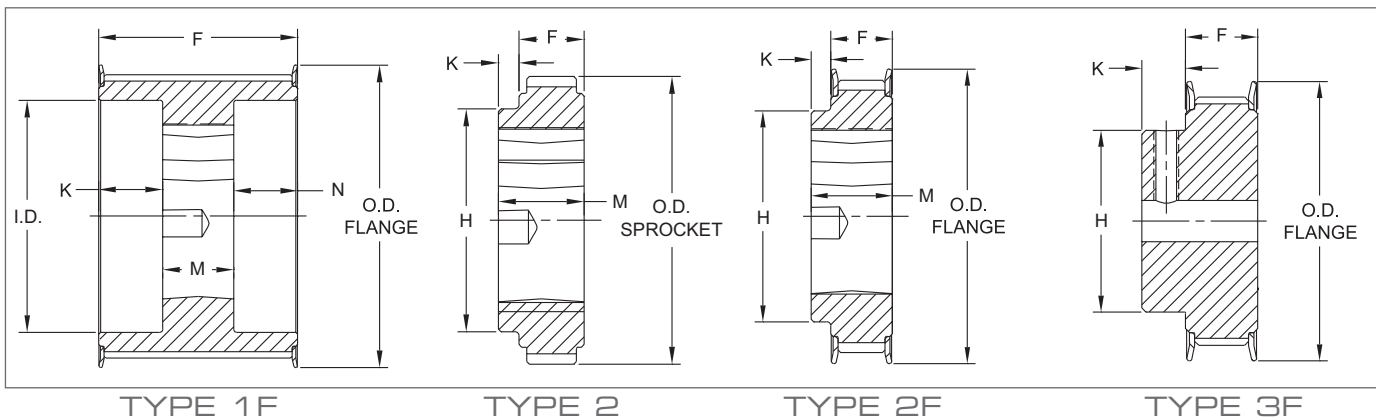

## L PITCH

**Warehouse Innovation**

**Color-coded product labels for easy stock retrieval on shelves**

**NOTE: these products are color-coded YELLOW**

### DIMENSIONS

Part No	List Price \$	Bushing	Number of Teeth	Diameters			Type	Dimensions (inches)				Bore Range		Wt	
				Pitch Diam.	O.D.			I.D.	K	M	N	H	Min.		Max.
					Sprocket	Flange									
<b>For Belts 1" wide - 3/8" pitch (L100) - Face width (F) = 1 1/4"</b>															
P13L100-PB	22.50	...	13	1.552	1.522	1.73	...	3B F	1/2	...	...	1 7/32	3/8	*3/4	0.60
P14L100-PB	23.30	...	14	1.671	1.641	1.89	...	3B F	1/2	...	...	1 5/16	3/8	*7/8	0.65
P15L100-PB	24.00	...	15	1.790	1.760	2.01	...	3B F	1/2	...	...	1 3/8	1/2	*7/8	0.74
P16L100-PB	24.80	...	16	1.910	1.880	2.13	...	3B F	1/2	...	...	1 1/2	1/2	*1	0.80
P17L100-PB	25.30	...	17	2.029	1.999	2.24	...	3B F	1/2	...	...	1 1/2	1/2	*1	1.00
P18L100-1108	32.00	1108	18	2.149	2.119	2.38	1.60	1B F	15/32	25/32	0	...	1/2	1 1/8	0.55
P20L100-1108	33.60	1108	20	2.387	2.357	2.64	1.77	1B F	15/32	25/32	0	...	1/2	1 1/8	0.80
P22L100-1108	36.40	1108	22	2.626	2.596	2.95	1.89	1B F	15/32	25/32	0	...	1/2	1 1/8	1.05
P24L100-1210	37.50	1210	24	2.865	2.835	3.13	2.24	1B F	9/32	63/64	0	...	1/2	1 1/4	1.25
P26L100-1210	40.00	1210	26	3.104	3.074	3.40	2.36	1B F	9/32	63/64	0	...	1/2	1 1/4	1.45
P28L100-1610	42.50	1610	28	3.342	3.312	3.59	2.54	1B F	9/32	63/64	0	...	1/2	1 11/16	1.45
P30L100-1610	46.10	1610	30	3.581	3.551	3.83	2.80	1B F	9/32	63/64	0	...	1/2	1 11/16	1.75
P32L100-1610	49.80	1610	32	3.820	3.790	4.04	2.95	1B F	9/32	63/64	0	...	1/2	1 11/16	2.15
P40L100-2012	67.90	2012	40	4.775	4.745	5.05	3.78	1B F	5/64	1 3/16	0	...	1/2	2 1/8	3.75
P48L100-2012	78.80	2012	48	5.730	5.700	5.91	4.72	1B F	5/64	1 3/16	0	...	1/2	2 1/8	6.10
P60L100-2012	92.70	2012	60	7.162	7.132	...	6.54	1W	5/64	1 3/16	0	...	1/2	2 1/8	6.95
P72L100-2012	112.20	2012	72	8.594	8.564	...	7.95	1W	5/64	1 3/16	0	...	1/2	2 1/8	10.60
P84L100-2517	128.70	2517	84	10.027	9.997	...	...	2W	33/64	1 49/64	...	4 11/16	1/2	2 11/16	15.15

\*Available from stock in min. plain bore. Max. bore is w/o keyway. (If keyway is used, reduce max. bore listed by twice the keyway depth.)

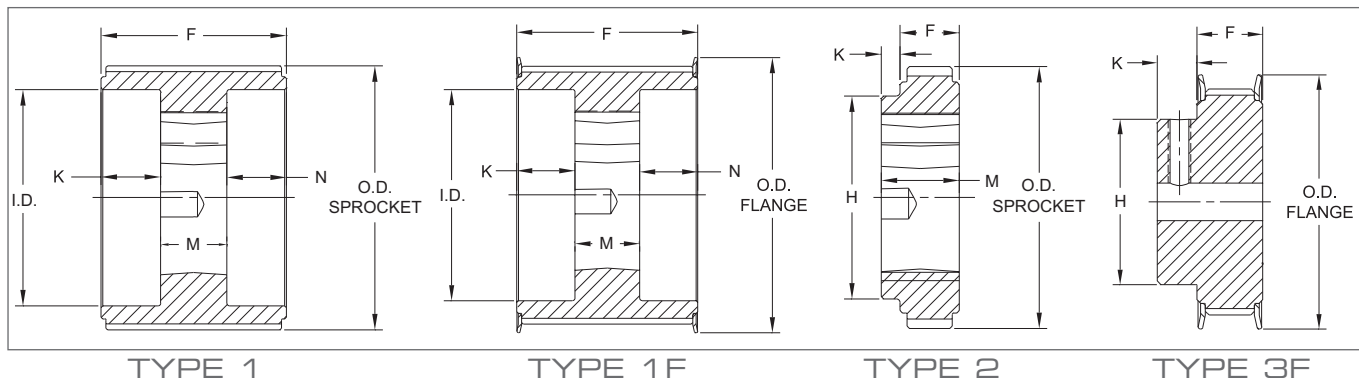

SYNCHRONOUS DRIVES

## H PITCH

Warehouse Innovation

Color-coded product labels for easy stock retrieval on shelves

**NOTE:** these products are color-coded **PURPLE**

### DIMENSIONS

Part No	List Price \$	Bushing	Number of Teeth	Diameters			I.D.	Type	Dimensions (inches)				Bore Range		Wt
				Pitch Diam.	O.D. Sprocket	O.D. Flange			K	M	N	H	Min.	Max.	
<b>For Belts 1" wide - 1/2" pitch (H100) - Face width (F) = 1 1/4"</b>															
*P14H100-1108	32.50	1108	14	2.228	2.174	2.52	1.60	1B F	7/16	25/32	0	...	1/2	1 1/8	0.70
*P16H100-1108	35.50	1108	16	2.546	2.492	2.77	1.77	1B F	7/16	25/32	0	...	1/2	1 1/8	0.90
*P18H100-1210	37.50	1210	18	2.865	2.811	3.12	2.24	1B F	15/64	63/64	0	...	1/2	1 1/4	1.00
*P20H100-1210	41.10	1210	20	3.183	3.129	3.40	2.36	1B F	15/64	63/64	0	...	1/2	1 1/4	1.45
P22H100-1610	48.90	1610	22	3.501	3.447	3.70	2.64	1B F	9/32	63/64	0	...	1/2	1 11/16	1.60
P24H100-1610	54.30	1610	24	3.820	3.766	4.04	2.89	1B F	9/32	63/64	0	...	1/2	1 11/16	2.10
P26H100-2012	62.00	2012	26	4.138	4.084	4.41	3.23	1B F	5/64	1 3/16	0	...	1/2	2 1/8	2.25
P28H100-2012	66.10	2012	28	4.456	4.402	4.74	3.56	1B F	5/64	1 3/16	0	...	1/2	2 1/8	2.95
P30H100-2012	69.70	2012	30	4.775	4.721	5.04	3.86	1B F	5/64	1 3/16	0	...	1/2	2 1/8	3.60
P32H100-2517	69.70	2517	32	5.093	5.039	5.32	...	2B F	33/64	1 49/64	...	4 11/64	1/2	2 11/16	4.20
P40H100-2517	92.30	2517	40	6.366	6.312	6.63	...	2W F	33/64	1 49/64	...	4 11/16	1/2	2 11/16	7.40
P48H100-2517	119.70	2517	48	7.639	7.585	7.87	...	2W F	33/64	1 49/64	...	4 11/16	1/2	2 11/16	9.95
**P60H100-3020	163.40	3020	60	9.549	9.495	...	...	2W	5/8	1 31/32	...	2 29/32	7/8	3 1/4	16.45
**P72H100-3020	166.60	3020	72	11.459	11.405	...	...	2W	5/8	1 31/32	...	5 29/32	7/8	3 1/4	22.75
**P84H100-3020	205.60	3020	84	13.369	13.315	...	...	2W	5/8	1 31/32	...	5 29/32	7/8	3 1/4	29.90
**P96H100-3020	256.60	3020	96	15.279	15.225	...	...	2A	5/8	1 31/32	...	5 29/32	7/8	3 1/4	28.75
**P120H100-3020	411.60	3020	120	19.099	19.045	...	...	2A	5/8	1 31/32	...	5 29/32	7/8	3 1/4	42.25

\* Face width (F) = 1 7/32"

\*\* Face width (F) = 1 11/32"

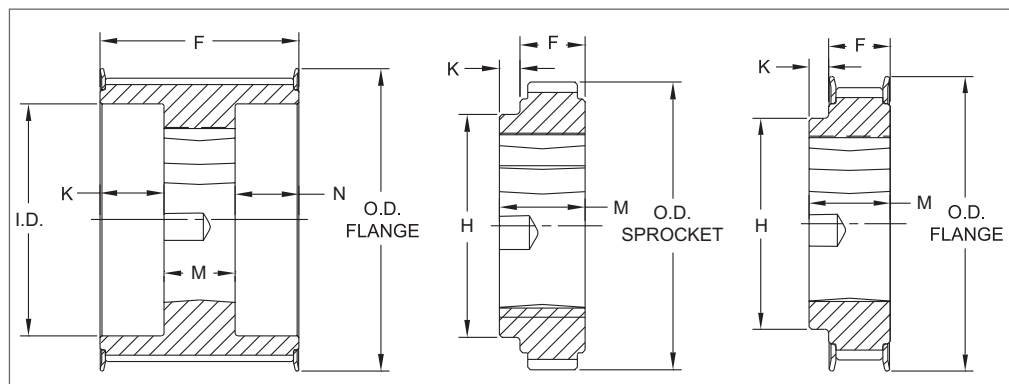

TYPE 1F

TYPE 2

TYPE 2F

## H PITCH

Warehouse Innovation

Color-coded product labels for easy stock retrieval on shelves

**NOTE:** these products are color-coded **PURPLE**

### DIMENSIONS

Part No	List Price \$	Bushing	Number of Teeth	Diameters			Type	Dimensions (inches)				Bore Range		Wt	
				Pitch Diam.	O.D.			I.D.	K	M	N	H	Min.		Max.
					Sprocket	Flange									
<b>For Belts 1 1/2" wide - 1/2" pitch (H150) - Face width (F) = 1 3/4"</b>															
P14H150-1108	43.20	1108	14	2.228	2.174	2.52	1.60	1B F	63/64	25/32	0	...	1/2	1 1/8	0.80
P16H150-1108	47.30	1108	16	2.546	2.492	2.77	1.77	1B F	63/64	25/32	0	...	1/2	1 1/8	1.20
P18H150-1210	48.90	1210	18	2.865	2.811	3.12	2.24	1B F	25/32	63/64	0	...	1/2	1 1/4	1.30
P20H150-1210	54.50	1210	20	3.183	3.129	3.40	2.36	1B F	25/32	63/64	0	...	1/2	1 1/4	1.85
P22H150-1610	61.10	1610	22	3.501	3.447	3.70	2.64	1B F	25/32	63/64	0	...	1/2	1 11/16	2.10
P24H150-2012	66.10	2012	24	3.820	3.766	4.04	3.13	1B F	19/32	1 3/16	0	...	1/2	2 1/8	2.05
P26H150-2012	73.40	2012	26	4.138	4.084	4.41	3.23	1B F	19/32	1 3/16	0	...	1/2	2 1/8	2.80
P28H150-2012	77.50	2012	28	4.456	4.402	4.74	3.56	1B F	19/32	1 3/16	0	...	1/2	2 1/8	3.50
P30H150-2012	81.80	2012	30	4.775	4.721	5.04	3.86	1B F	19/32	1 3/16	0	...	1/2	2 1/8	4.30
P32H150-2517	82.90	2517	32	5.093	5.039	5.32	...	2B F	0	1 49/64	...	...	1/2	2 11/16	4.90
P40H150-2517	107.70	2517	40	6.366	6.312	6.63	...	2W F	0	1 49/64	...	...	1/2	2 11/16	8.20
P48H150-2517	138.90	2517	48	7.639	7.585	7.87	...	2W F	0	1 49/64	...	...	1/2	2 11/16	11.25
P60H150-3020	153.40	3020	60	9.549	9.495	...	...	2W	13/64	1 31/32	...	6 19/64	7/8	3 1/4	10.80
P72H150-3020	193.10	3020	72	11.459	11.405	...	...	2W	13/64	1 31/32	...	6 19/64	7/8	3 1/4	25.20
P84H150-3020	240.50	3020	84	13.369	13.315	...	...	2W	13/64	1 31/32	...	6 19/64	7/8	3 1/4	32.40
P96H150-3020	304.80	3020	96	15.279	15.225	...	...	2A	13/64	1 31/32	...	6 19/64	7/8	3 1/4	31.52
P120H150-3020	499.80	3020	120	19.099	19.045	...	...	2A	13/64	1 31/32	...	6 19/64	7/8	3 1/4	46.50

SYNCHRONOUS DRIVES

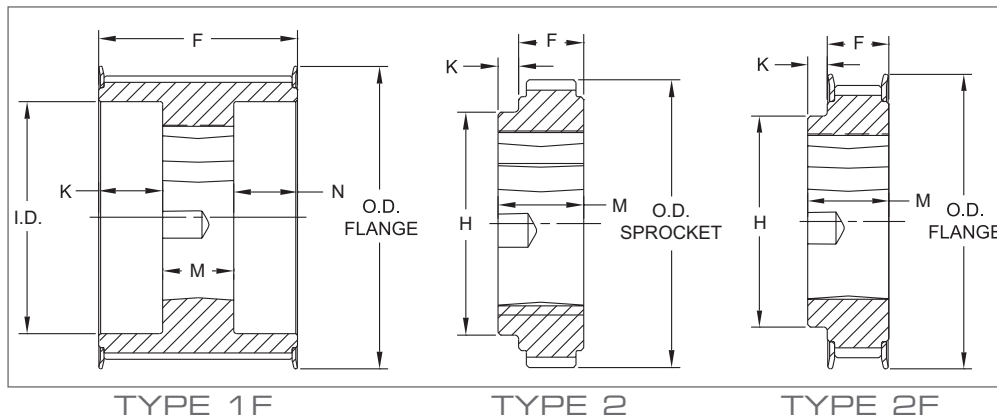

## H PITCH

Warehouse Innovation

Color-coded product labels for easy stock retrieval on shelves

**NOTE:** these products are color-coded **PURPLE**

### DIMENSIONS

Part No	List Price \$	Bushing	Number of Teeth	Diameters			I.D.	Type	Dimensions (inches)				Bore Range		Wt
				Pitch Diam.	O.D.				K	M	N	H	Min.	Max.	
					Sprocket	Flange									
<b>For Belts 2" wide - 1/2" pitch (H200) - Face width (F) = 2 9/32"</b>															
P16H200-1108	60.00	1108	16	2.546	2.492	2.77	1.77	1B F	1 1/2	25/32	0	...	1/2	1 1/8	1.50
P18H200-1210	62.70	1210	18	2.865	2.811	3.12	2.24	1B F	1 19/64	63/64	0	...	1/2	1 1/4	1.50
P20H200-1210	69.30	1210	20	3.183	3.129	3.40	2.36	1B F	1 19/64	63/64	0	...	1/2	1 1/4	2.30
P22H200-1610	71.80	1610	22	3.501	3.447	3.70	2.64	1B F	1 19/64	63/64	0	...	1/2	1 11/16	2.55
P24H200-2012	76.60	2012	24	3.820	3.766	4.04	3.15	1B F	1 7/64	1 3/16	0	...	1/2	2 1/8	2.45
P26H200-2012	83.20	2012	26	4.138	4.084	4.41	3.23	1B F	1 7/64	1 3/16	0	...	1/2	2 1/8	3.40
P28H200-2012	88.90	2012	28	4.456	4.402	4.74	3.56	1B F	1 7/64	1 3/16	0	...	1/2	2 1/8	4.15
P30H200-2012	95.00	2012	30	4.775	4.721	5.04	3.86	1B F	1 7/64	1 3/16	0	...	1/2	2 1/8	4.90
P32H200-2517	97.90	2517	32	5.093	5.039	5.32	4.17	1B F	33/64	1 49/64	0	...	1/2	2 11/16	5.75
P40H200-2517	142.00	2517	40	6.366	6.312	6.63	5.43	1W F	33/64	1 49/64	0	...	1/2	2 11/16	9.30
P48H200-3020	191.80	3020	48	7.639	7.585	7.87	6.65	1B F	5/16	1 31/32	0	...	7/8	3 1/4	16.40
*P60H200-3020	205.40	3020	60	9.549	9.495	...	8.78	1W	25/64	1 31/32	0	...	7/8	3 1/4	20.10
*P72H200-3020	258.40	3020	72	11.459	11.405	...	10.62	1W	25/64	1 31/32	0	...	7/8	3 1/4	27.15
*P84H200-3020	292.80	3020	84	13.369	13.315	...	12.60	1W	25/64	1 31/32	0	...	7/8	3 1/4	34.62
*P96H200-3535	352.70	3535	96	15.279	15.225	...	...	2A	1 9/64	3 1/2	...	7 1/64	1 3/16	3 15/16	43.95
*P120H200-3535	587.70	3535	120	19.099	19.045	...	...	2A	1 9/64	3 1/2	...	7 1/64	1 3/16	3 15/16	58.92

\*Face width (F) = 2 11/32"

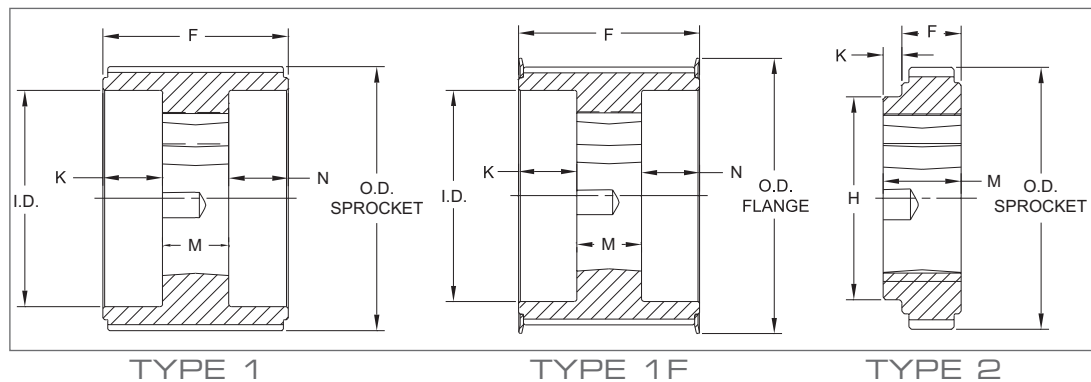

## H PITCH

Warehouse Innovation

Color-coded product labels for easy stock retrieval on shelves

**NOTE:** these products are color-coded **PURPLE**

### DIMENSIONS

Part No	List Price \$	Bushing	Number of Teeth	Diameters			Type	Dimensions (inches)				Bore Range		Wt	
				Pitch Diam.	O.D.			I.D.	K	M	N	H	Min.		Max.
					Sprocket	Flange									
<b>For Belts 3" wide - 1/2" pitch (H300) - Face width (F) = 3 5/16"</b>															
P16H300-1108	79.70	1108	16	2.546	2.492	2.77	1.82	1B F	1 17/64	25/32	1 17/64	...	1/2	1 1/8	2.00
P18H300-1210	88.60	1210	18	2.865	2.811	3.12	2.24	1B F	1 5/32	63/64	1 5/32	...	1/2	1 1/4	2.05
P20H300-1210	107.70	1210	20	3.183	3.129	3.40	2.36	1B F	1 5/32	63/64	1 5/32	...	1/2	1 1/4	3.05
P22H300-1610	106.80	1610	22	3.501	3.447	3.70	2.64	1B F	1 5/32	63/64	1 5/32	...	1/2	1 11/16	3.50
P24H300-2012	114.30	2012	24	3.820	3.766	4.04	2.95	1B F	1 1/16	1 3/16	1 1/16	...	1/2	2 1/8	4.05
P26H300-2012	120.70	2012	26	4.138	4.084	4.41	3.23	1B F	1 1/16	1 3/16	1 1/16	...	1/2	2 1/8	4.60
P28H300-2012	127.30	2012	28	4.456	4.402	4.74	3.56	1B F	1 1/16	1 3/16	1 1/16	...	1/2	2 1/8	5.40
P30H300-2012	140.50	2012	30	4.775	4.721	5.04	3.86	1B F	1 1/16	1 3/16	1 1/16	...	1/2	2 1/8	6.45
P32H300-2517	148.80	2517	32	5.093	5.039	5.32	4.17	1B F	49/64	1 49/64	49/64	...	1/2	2 11/16	7.25
P40H300-2517	184.20	2517	40	6.366	6.312	6.63	5.43	1W F	1 17/32	1 49/64	0	...	1/2	2 11/16	11.40
**P48H300-3020	254.90	3020	48	7.639	7.585	7.87	6.65	1B F	1 27/64	1 31/32	0	...	7/8	3 1/4	19.25
**P60H300-3020	254.50	3020	60	9.549	9.495	...	8.78	1W	1 27/64	1 31/32	0	...	7/8	3 1/4	22.60
**P72H300-3020	332.00	3020	72	11.459	11.405	...	10.62	1W	1 27/64	1 31/32	0	...	7/8	3 1/4	30.70
**P84H300-3020	412.60	3020	84	13.369	13.315	...	12.60	1W	1 27/64	1 31/32	0	...	7/8	3 1/4	37.45
**P96H300-3535	494.20	3535	96	15.279	15.225	...	...	2A	1/8	3 1/2	...	7 1/64	1 3/16	3 15/16	51.84
**P120H300-3535	704.80	3535	120	19.099	19.045	...	...	2A	1/8	3 1/2	...	7 1/64	1 3/16	3 15/16	75.08

\*\* Face width (F) = 3 3/8"

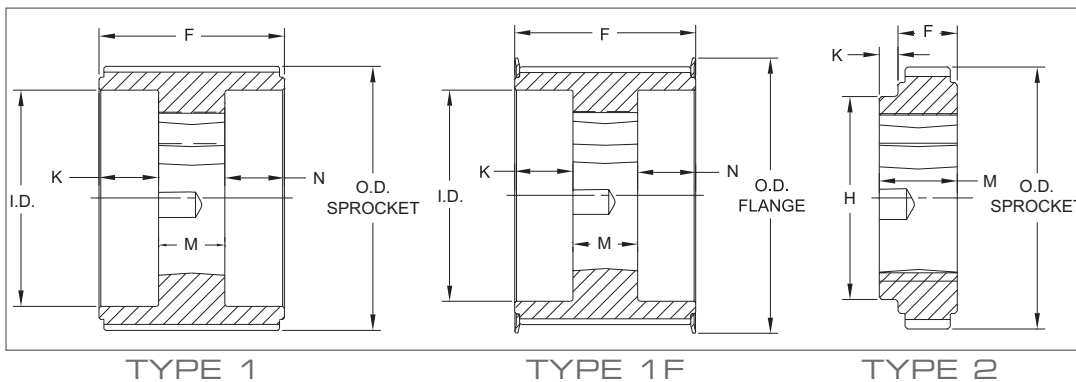

SYNCHRONOUS DRIVES