

MVS

SHEAVES

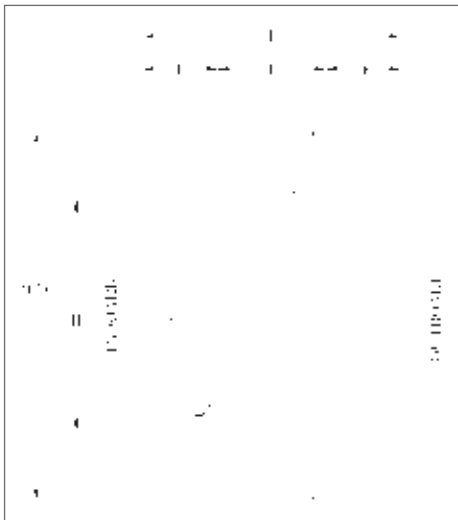
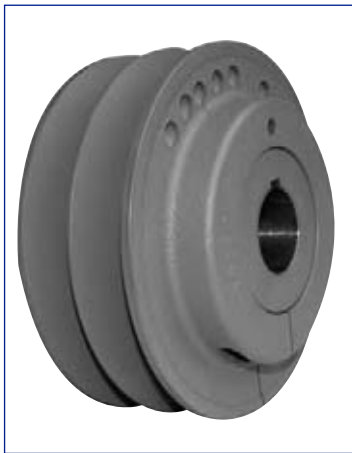

DID YOU KNOW THAT...

- Designed for up to 40 HP @ 1750 RPM
- Used with A, B, 3V & 5V belts

IMPORTANT REMINDER



- Every turn of the adjustment screw moves the flange by 1/16".

HOW TO ORDER

EXAMPLE: **MVS150X1-3/8**

MVS150

X1-3/8

MVS150: ADJUSTABLE PITCH SHEAVE SIZE

Last three digits represent the outside diameter in MM. 150 MM = 5.905"

X1-3/8: BORE SIZE (1 3/8")

Bore size: Inch bore sizes are designated with the whole inch followed by the fraction. For example, a 1.5" diameter bore would be 1-1/2.

Pulley Adjustment

Modify the sheave pitch diameter by using the adjustment screw. Every turn of the adjustment screw moves the flanges by 1/16". Once the required diameter is obtained, tighten the locking screw.

ADJUSTABLE PITCH HEAVY DUTY MVS

DIMENSIONS

Part No.	List Price \$	O.D.	Dimensions						Stock Bores Marked "X"					WT (lbs)
			F		E		L	H	1 1/8	1 3/8	1 5/8	1 7/8	2 1/8	
			Min.	Max.	Min.	Max.								
MVS130	228.00	5.118	1.73	2.27	0.75	1.02	3.77	3.15	X	X	-	-	-	8.5
MVS150	250.00	5.905	1.73	2.59	0.77	1.20	4.13	3.62	X	X	X	-	-	12.1
MVS170	272.00	6.692	1.73	2.59	0.77	1.20	4.13	3.62	X	X	X	-	-	14.8
MVS190	294.00	7.480	1.73	2.59	0.77	1.20	4.13	5.12	-	X	X	X	-	23.2
MVS210	316.00	8.268	1.73	2.59	0.77	1.20	4.13	5.12	-	X	X	X	X	27.0
MVS230	338.00	9.055	1.73	2.59	0.77	1.20	4.13	5.12	-	X	X	X	X	30.40

DATUM DIAMETERS

	Part No.	Datum Diameter, Inches									
		Min.	Max.	0 Turn Close	1 Turn Open	2 Turns Open	3 Turns Open	4 Turns Open	5 Turns Open	6 Turns Open	7 Turns Open
A Belt	MVS130	3.45	4.47	4.47	4.26	4.06	3.85	3.65	3.45	-	-
	MVS150	4.23	5.25	5.25	5.05	4.85	4.64	4.44	4.23	-	-
	MVS170	4.81	6.04	6.04	5.84	5.63	5.43	5.22	5.02	4.81	-
	MVS190	5.60	6.83	6.83	6.62	6.42	6.21	6.01	5.81	5.60	-
	MVS210	6.40	7.63	7.63	7.43	7.22	7.02	6.81	6.61	6.40	-
	MVS230	7.19	8.42	8.42	8.21	8.01	7.81	7.60	7.40	7.19	-
B Belt	MVS130	3.63	4.86	4.86	4.65	4.45	4.24	4.04	3.84	3.63	-
	MVS150	4.21	5.65	5.65	5.44	5.24	5.03	4.83	4.62	4.42	4.21
	MVS170	5.00	6.43	6.43	6.23	6.02	5.82	5.61	5.41	5.21	5.00
	MVS190	5.79	7.22	7.22	7.01	6.81	6.60	6.40	6.20	5.99	5.79
	MVS210	6.59	8.02	8.02	7.82	7.61	7.41	7.20	7.00	6.80	6.59
	MVS230	7.38	8.81	8.81	8.61	8.40	8.20	7.99	7.79	7.58	7.38
3V Belt	MVS130	3.56	4.17	4.17	3.97	3.77	3.56	-	-	-	-
	MVS150	4.35	4.96	4.96	4.76	4.55	4.35	-	-	-	-
	MVS170	5.13	5.75	5.75	5.54	5.34	5.13	-	-	-	-
	MVS190	5.92	6.53	6.53	6.33	6.13	5.92	-	-	-	-
	MVS210	6.73	7.34	7.34	7.13	6.93	6.73	-	-	-	-
	MVS230	7.51	8.13	8.13	7.92	7.72	7.51	-	-	-	-
5V Belt	MVS130	-	-	-	-	-	-	-	-	-	-
	MVS150*	4.31	5.74	5.74	5.54	5.33	5.13	4.93	4.72	4.52	4.31
	MVS170*	5.10	6.53	6.53	6.33	6.12	5.92	5.71	5.51	5.30	5.10
	MVS190	5.88	7.32	7.32	7.11	6.91	6.70	6.50	6.29	6.09	5.88
	MVS210	6.69	8.12	8.12	7.92	7.71	7.51	7.30	7.10	6.89	6.69
	MVS230	7.48	8.91	8.91	8.70	8.50	8.29	8.09	7.89	7.68	7.48

* IMPORTANT: Recommended for use with narrow cog belts only.

P.D. for "A" belt = Datum Dia. "A" belt + .25

P.D. for "3V" belts = Datum Dia. "3V" belts + .05

P.D. for "B" belt = Datum Dia. "B" belt + .35

P.D. for "5V" belts = Datum Dia. "5V" belts + .10