

MASKA STARFLEX: ELASTOMERIC JAW TYPE COUPLINGS

The most commonly used elastomeric coupling for a wide variety of light to medium-duty applications.

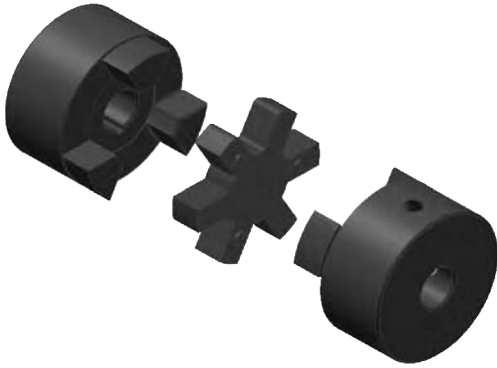

DID YOU KNOW THAT...

- All parts are completely machined in cast iron
- Interchangeable by part number and size with corresponding components
- Cost saving component
- 4 types of insert materials for various applications in varying temperatures and environments

IMPORTANT REMINDER



Careful selection of the type of insert based on the service factor will result in efficient, long-lasting operations



Product Features

- High torque capability
- Easy Installation
- Misalignment capability
- No metal-to-metal contact

HOW TO ORDER

STOCK BORE COUPLING

EXAMPLE: **L099X5/8**

L099

X5/8

L099: MASKA STARFLEX HUB SIZE

X5/8: BORE SIZE (5/8")

ELEMENT MATERIAL

EXAMPLE: **L099-100H**

L099-100

H

L099-100: MASKA STARFLEX element size (insert)

H : MATERIAL (HYTREL)





To order a complete coupling, (2) hubs with appropriate bore and (1) insert have to be ordered.

IMPORTANT REMINDER



Selecting the proper insert material is just as important as selecting the correct type and size of jaw coupling because of the role they play in the performance and maintenance of the product.

ELEMENT CHARACTERISTICS

Properties	Temperature Range	Misalignment		Shore Hardness	Dampening Capacity	Chemical Resistance	Colour
		Angular Degree	Parallel Inch				
<p>NBR (Rubber) Nitrile Butadiene Rubber is an elastomeric element that is oil resistant with the resilience and elasticity of natural rubber.</p> <p>Most economical and widely-used element.</p>	<p>-40° to +212° F</p> <p>-40° to +100° C</p>	1°	.015	80A	HIGH	GOOD	<p>BLACK</p> 
<p>Urethane -- Urethane has 1.5 more torque capability than NBR, provides less dampening effect and has good resistance to oil and chemicals.</p> <p>Not recommended for cyclic or start-stop applications.</p>	<p>-30° to +160° F</p> <p>-34° to +71° C</p>	1°	.015	<p>55D</p> <p>L050-L110</p> <p>90-95A</p> <p>L150-L225</p>	LOW	VERY GOOD	<p>ORANGE</p> 
<p>Hytrel -- Hytrel is a pliant elastomer suited to high torque / temperature operations. Notable resistance to oil and chemicals</p> <p>Not recommended for cyclic or start-stop applications.</p>	<p>-60° to +250° F</p> <p>-51° to 121° C</p>	1/2°	.015	55D	LOW	EXCELLENT	<p>BEIGE</p> 
<p>Bronze -- Bronze is a metal insert designed exclusively for slow speed operations that require high torque. (Maximum 250 RPM)</p> <p>Resistant to extreme environments (temperature, water, oil, dirt).</p>	<p>-40° to +450° F</p> <p>-40° to +232° C</p>	1/2°	.010	--	NIL	EXCELLENT	<p>GOLD</p> 

Jaw Couplings Advantages

Jaw design is considered “fail-safe” - if the insert element wears/breaks away, the coupling continues to operate until insert can be conveniently replaced.

Simple design means easy installation, removal and visual inspection. Also offers lighter weight and lower cost vs. torque capacity.

Insert Choice

The choice of the insert element can make a significant difference in the couplings’s performance with regards to vibration, temperature, chemicals, misalignment, high rpm, space limitations and installation/removal.

Maintenance Tips

Through manual inspection, avoid allowing the jaw tips to come into contact; a noisy, grinding operation will result. Do not hesitate to replace the insert if signs of wear are evident.

Do not over-estimate service factors when choosing the coupling / insert. This increases costs unnecessarily and can cause damage elsewhere in the drive. Due to the variety of inserts available, careful selection will result in efficient, long-lasting operations.

GENERAL ORDERING INFORMATION

HUB AND ELEMENTS

Hub No.	List Price (\$)		Insert Elements										
			NBR (Rubber)		Urethane		Hytrel		Wt. lbs.	Bronze			
	Inches	Metric	Part No.	List Price	Part No.	List Price	Part No.	List Price		Part No.	List Price	Wt. lbs.	
L035* (4)	13.00	-	L035N* (4)	8.40	-	-	-	-	-	.01	-	-	-
L050* (4)	13.00	15.60	L050N* (4)	8.40	L050U* (4)	34.00	L050H* (4)	28.40	.01	L050B* (4)	47.60	.06	
L070	5.05	6.06	L070N	3.00	L070U	5.90	L070H	10.00	.02	L070B	14.50	.07	
L075	5.80	6.96	L075N	5.10	L075U	7.30	L075H	15.00	.03	L075B	23.20	.10	
L090	8.90	10.68	L090-095N	6.60	L090-095U	10.50	L090-095H	20.00	.04	L090-095B	25.60	.17	
L095	13.70	16.44	L090-095N	6.60	L090-095U	10.50	L090-095H	20.00	.04	L090-095B	25.60	.17	
L099	17.30	20.76	L099-100N	13.90	L099-100U	27.60	L099-100H	47.60	.07	L099-100B	37.80	.33	
L100	25.60	30.72	L099-100N	13.90	L099-100U	27.60	L099-100H	47.60	.07	L099-100B	37.80	.33	
L110	35.00	42.00	L110N	16.00	L110U	52.40	L110H	57.60	.14	L110B	45.40	.63	
L150	44.80	53.76	L150N	23.00	L150U	63.40	L150H	69.20	.21	L150B	146.00	1.01	
L190	70.00	84.00	L190N	28.00	L190U	68.40	L190H	81.60	.27	L190B	222.00	1.35	
L225	85.00	102.00	L225N	33.50	L225U	86.60	L225H	95.80	.41	L225B	284.00	2.05	

*Important: NOT SOLD INDIVIDUALLY. These parts are packaged 4 to a box.

COUPLINGS



DIMENSIONS

Hub No.	Type	Outside Diameter A	Hub Diameter HD	Overall Length B	Distance between flanges C	Length thru bore D	Bore		Assy Wt. Lbs. (Avg)	Approx. WR2 lbs-in2
							Min.	Max.		
L035 *	1	5/8	-	13/16	9/32	17/64	1/8 (4mm)	3/8 (8mm)	0.10	0.003
L050 *	1	1 1/16	-	1 23/32	15/32	5/8	3/16 (5mm)	5/8 (16mm)	0.25	0.054
L070	1	1 3/8	-	2	1/2	3/4	3/16 (7mm)	3/4 (19mm)	0.50	0.115
L075	1	1 3/4	-	2 1/8	1/2	13/16	3/16 (9mm)	7/8 (22mm)	0.90	0.388
L090	1	2 1/8	-	2 9/64	33/64	13/16	3/16 (8mm)	1 (25mm)	1.35	0.772
L095	1	2 1/8	-	2 33/64	33/64	1	7/16 (11mm)	1 1/8 (28mm)	1.55	0.890
L099	1	2 17/32	-	2 27/32	23/32	1 1/16	7/16 (14mm)	1 3/16 (30mm)	2.25	2.048
L100	1	2 17/32	-	3 15/32	23/32	1 3/8	7/16 (12mm)	1 3/8 (35mm)	2.80	2.783
L110	1	3 5/16	-	4 1/4	7/8	1 11/16	5/8 (16mm)	1 5/8 (42mm)	5.95	8.993
L150	1	3 3/4	-	4 1/2	1	1 3/4	5/8 (16mm)	1 7/8 (48mm)	7.90	11.477
L190	2	4 1/2	4	5	1	2	3/4 (19mm)	2 1/8 (55mm)	13.80	39.256
L225	2	5	4 1/4	5 3/8	1	2 3/16	3/4 (30mm)	2 5/8 (65mm)	17.30	65.000

*Important: NOT SOLD INDIVIDUALLY. These parts are packaged 4 to a box.

WRENCH TORQUE TO TIGHTEN SCREWS

Hub No.	Qty.	Set Screws		Tightening torque in-lbs.
		Size		
		Inch Series	Metric Series	
L035	1	#6-32	-	7
L050	2	1/4-20	M4-0.7	45
L070	2	1/4-20	M6-1	78
L075	2	1/4-20	M6-1	78
L090	2	1/4-20	M6-1	78
L095	2	5/16-18	M8-1.25	80
L099	2	5/16-18	M8-1.25	150
L100	2	5/16-18	M8-1.25	150
L110	2	3/8-16	M10-1.5	225
L150	2	3/8-16	M10-1.5	260
L190	2	1/2-13	M12-1.75	540
L225	2	1/2-13	M12-1.75	540

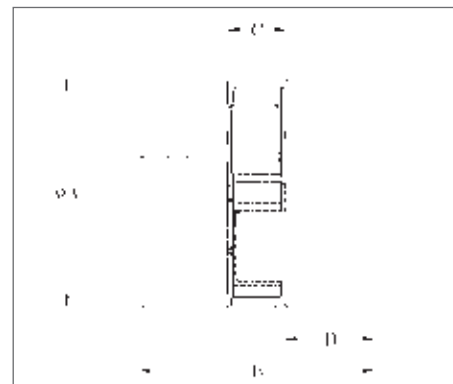

TYPE 1

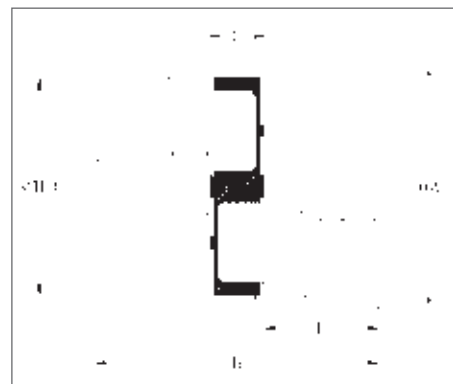

TYPE 2

STARFLEX COUPLINGS

INCH SERIES: STANDARD BORES AND KEYWAYS

Bore (in)	Keyway (in)	L035	L050	L070	L075	L090	L095	L099	L100	L110	L150	L190	L225
1/8	No KW	X											
3/16	No KW	X	X	X	X	X							
1/4	No KW	X	X	X	X	X							
1/4KW	1/8 x 1/16				POR								
5/16	No KW	X	X	X	X	X							
3/8	No KW	X	X	X	X	X							
3/8KW3/32	3/32 x 3/64		POR	POR	POR	POR							
3/8KW1/8	1/8 x 1/16		POR	POR	POR	POR							
7/16	No KW		X	X	X	X	X	X	X				
7/16KW3/32	3/32 x 3/64		POR	X	POR	POR	POR	POR	POR				
7/16KW1/8	1/8 x 1/16			POR	POR	POR	POR	POR	POR				
1/2	No KW		X	X	X	X	X	X	X				
1/2KW	1/8 x 1/16		X	X	X	X	X	X	X				
9/16NOKW	No KW		POR	POR	POR	POR	POR	POR	POR				
9/16	1/8 x 1/16		X	X	X	X	X	X	X				
5/8NOKW	No KW		POR	X	POR	POR	POR	POR	POR	POR	POR		
5/8KW5/32	5/32 x 5/64			POR	POR	POR	POR	X	POR	POR	POR		
5/8	3/16 x 3/32		X	X	X	X	X	X	X	X	X		
11/16	3/16 x 3/32			X	X	X	X	X	X	X	X		
3/4NOKW	No KW			POR	POR	POR	POR	POR	POR			POR	POR
3/4KW1/8	1/8 x 1/16			POR	POR	POR	POR	POR	POR	POR	POR	POR	
3/4	3/16 x 3/32			X	X	X	X	X	X	X	X	X	X
13/16	3/16 x 3/32				X	X	X	X	X	X	X	X	X
7/8NOKW	No KW				POR			POR					
7/8	3/16 x 3/32				X	X	X	X	X	X	X	X	X
7/8KW1/4	1/4 x 1/8					POR	POR	POR	POR	POR	POR	POR	POR
15/16	1/4 x 1/8					X	X	X	X	X	X	X	X
1	1/4 x 1/8					X	X	X	X	X	X	X	X
1KW	3/16 x 3/32					POR	POR	POR	POR	POR	POR	POR	POR
1 1/16	1/4 x 1/8						X	X	X	X	X	X	X
1 1/8	1/4 x 1/8						X	X	X	X	X	X	X
1 3/16	1/4 x 1/8							X	X	X	X	X	X
1 1/4	1/4 x 1/8								X	X	X	X	X
1 1/4KW	5/16 x 5/32								POR	POR	POR	POR	POR
1 5/16	5/16 x 5/32								X	X	X	X	X
1 3/8KW	5/16 x 5/32								X	X	X	X	X
1 3/8	3/8 x 3/16								POR	POR	POR	POR	POR
1 7/16	3/8 x 3/16									X	X	X	X
1 1/2KW	5/16 x 5/32									POR	POR	POR	POR
1 1/2	3/8 x 3/16									X	X	X	X
1 9/16	3/8 x 3/16									X	X	X	X
1 5/8	3/8 x 3/16									X	X	X	X
1 11/16	3/8 x 3/16										X	X	X
1 3/4	3/8 x 3/16										X	X	X
1 3/4KW	7/16 x 7/32										POR	POR	POR
1 13/16	1/2 x 1/4										X	X	X
1 7/8	1/2 x 1/4										X	X	X
1 15/16	1/2 x 1/4											X	X
2	1/2 x 1/4											X	X
2 1/16	1/2 x 1/4											X	X
2 1/8	1/2 x 1/4											X	X
2 3/16	1/2 x 1/4												X
2 1/4	1/2 x 1/4												X
2 3/8	5/8 x 5/16												X
2 5/8	5/8 x 5/16												X

X = Stock POR = Price on Request

135

FOR DEPENDABLE DRIVE COMPONENTS,

COUPLINGS

STARFLEX COUPLINGS

METRIC SERIES: STANDARD BORES AND KEYWAYS

Bore (mm)	Keyway (mm)	L035	L050	L070	L075	L090	L095	L099	L100	L110	L150	L190	L225
4	No KW	POR											
5	No KW	POR	POR										
6	No KW	POR	POR										
7	No KW	POR	POR	POR									
8	No KW	POR	POR	POR		POR							
9	3 x 1.4		POR	POR	POR								
10	No KW		POR	POR	POR								
10	3 x 1.4		X	POR	POR	POR							
11	4 x 1.8		X	X	POR		POR						
12	No KW		POR	POR		POR							
12	4 x 1.8		X	X	X	POR	POR		POR				
14	No KW		POR	POR		POR	POR						
14	5 x 2.3		POR	X	X	POR	POR	POR	POR				
15	No KW		POR		POR		POR	POR	POR				
15	5 x 2.3		POR	X	X	POR	POR	POR	POR				
16	5 x 2.3		POR	X	X	POR	POR	POR	POR	POR	POR		
17	5 x 2.3			POR	POR	X	POR		POR	POR	POR		
18	6 x 2.8			POR	POR	POR	POR	POR	POR	POR			
19	No KW					POR				POR			
19	6 x 2.8			X	X	X	X	POR	POR	POR	POR	POR	
20	6 x 2.8				X	X	X	POR	POR	POR	POR	POR	
22	6 x 2.8				X	X	X	X	POR	POR	POR		
24	8 x 3.3					X	X	X	X	X	POR	POR	
25	8 x 3.3					POR	X	X	X	X	POR	POR	
28	No KW										POR	POR	
28	8 x 3.3						X	X	X	X	POR	POR	
30	8 x 3.3							POR	X	X	POR	POR	POR
32	No KW										POR	POR	POR
32	10 x 3.3								POR	X	X	POR	POR
35	No KW										POR	POR	POR
35	10 x 3.3								POR	POR	POR	POR	X
38	10 x 3.3									X	X	POR	POR
40	12 x 3.3									POR	POR	POR	POR
42	12 x 3.3									X	X	X	POR
45	14 x 3.8										X	POR	POR
48	No KW										POR		
48	14 x 3.8										POR	POR	X
50	No KW											POR	POR
50	14 x 3.8											POR	POR
55	No KW											POR	POR
55	16 x 4.3											X	X
60	No KW												POR
60	18 x 4.4												POR
65	No KW												
65	18 x 4.4												POR

X = Stock POR = Price on Request

COUPLINGS

COUPLING RATINGS & MISALIGNMENT

NBR - (NITRILE BUTADIENE RUBBER)
ELEMENT MATERIAL

Hub Size	Element Material	Max RPM	HP per 100 RPM Service Factor					Torque (in. lbs.)	Max. parallel misalignment (in.)	Max. angular misalignment (in.)
			1.0	1.5	2.0	2.5	3.0			
L035		31000	0.006	0.004	0.003	0.002	0.002	3.5	0.015	0.010
L050		18000	0.042	0.028	0.021	0.017	0.014	26.3	0.015	0.018
L070		14000	0.069	0.046	0.035	0.028	0.023	43.2	0.015	0.022
L075		11000	0.143	0.095	0.072	0.057	0.048	90	0.015	0.030
L090		9000	0.228	0.152	0.114	0.091	0.076	144	0.015	0.035
L095		9000	0.308	0.205	0.154	0.123	0.103	194	0.015	0.035
L099		7000	0.505	0.337	0.253	0.202	0.168	318	0.015	0.040
L100		7000	0.662	0.441	0.331	0.265	0.221	417	0.015	0.040
L110		5000	1.257	0.838	0.629	0.503	0.419	792	0.015	0.055
L150		5000	1.967	1.311	0.984	0.787	0.656	1240	0.015	0.065
L190		5000	2.742	1.828	1.371	1.097	0.914	1728	0.015	0.075
L225		4200	3.713	2.475	1.857	1.485	1.238	2340	0.015	0.085

URETHANE - ELEMENT MATERIAL

Hub Size	Element Material	Max RPM	HP per 100 RPM Service Factor					Torque (in. lbs.)	Max. parallel misalignment (in.)	Max. angular misalignment (in.)
			1.0	1.5	2.0	2.5	3.0			
L035		31000	-	-	-	-	-	-	-	-
L050		18000	0.062	0.041	0.031	0.025	0.021	39	0.015	0.018
L070		14000	0.103	0.069	0.052	0.041	0.034	65	0.015	0.022
L075		11000	0.214	0.143	0.107	0.086	0.071	135	0.015	0.030
L090		9000	0.343	0.229	0.172	0.137	0.114	216	0.015	0.035
L095		9000	0.462	0.308	0.231	0.185	0.154	291	0.015	0.035
L099		7000	0.757	0.505	0.379	0.303	0.252	477	0.015	0.040
L100		7000	0.993	0.662	0.497	0.397	0.331	626	0.015	0.040
L110		5000	1.885	1.257	0.943	0.754	0.628	1188	0.015	0.055
L150		5000	2.951	1.967	1.476	1.180	0.984	1860	0.015	0.065
L190		5000	4.113	2.742	2.057	1.645	1.371	2592	0.015	0.075
L225		4200	5.569	3.713	2.785	2.228	1.856	3510	0.015	0.085

NOTE: Angular misalignment is the difference between X and X max. Refer to Figure 2 on the following page.

STARFLEX COUPLINGS

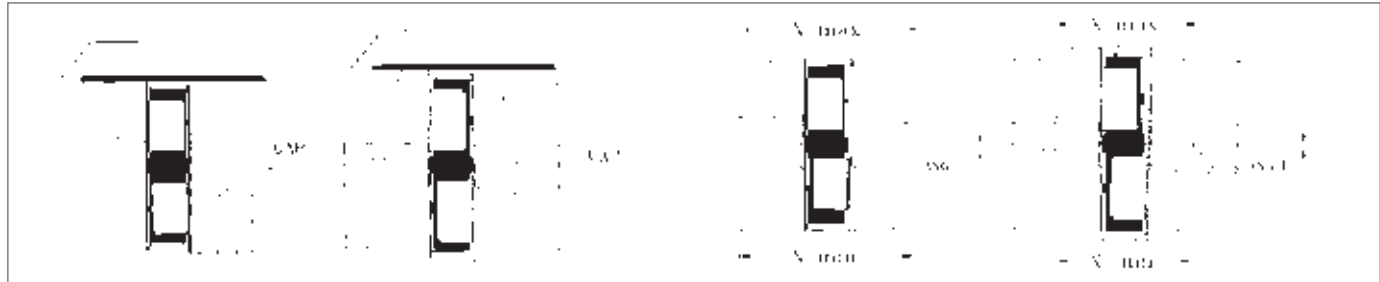

Parallel Misalignment
Figure 1

Angular Misalignment
Figure 2

HYTREL - ELEMENT MATERIAL

Hub Size	Element Material	Max RPM	HP per 100 RPM Service Factor					Torque (in. lbs.)	Max. parallel misalignment (in.)	Max. angular misalignment (in.)
			1.0	1.5	2.0	2.5	3.0			
L035		31000	-	-	-	-	-	-	-	-
L050		18000	0.079	0.053	0.040	0.032	0.026	50	0.015	0.012
L070		14000	0.181	0.121	0.091	0.072	0.060	114	0.015	0.012
L075		11000	0.360	0.240	0.180	0.144	0.120	227	0.015	0.015
L090		9000	0.636	0.424	0.318	0.254	0.212	401	0.015	0.018
L095		9000	0.890	0.593	0.445	0.356	0.297	561	0.015	0.018
L099		7000	1.257	0.838	0.629	0.503	0.419	792	0.015	0.022
L100		7000	1.799	1.199	0.900	0.720	0.600	1134	0.015	0.022
L110		5000	3.599	2.399	1.800	1.440	1.200	2268	0.015	0.030
L150		5000	5.883	3.922	2.942	2.353	1.961	3708	0.015	0.033
L190		5000	7.426	4.951	3.713	2.970	2.475	4680	0.015	0.040
L225		4200	9.882	6.588	4.941	3.953	3.294	6228	0.015	0.044

BRONZE - ELEMENT MATERIAL

Hub Size	Element Material	Max RPM	HP per 100 RPM Service Factor					Torque (in. lbs.)	Max. parallel misalignment (in.)	Max. angular misalignment (in.)
			1.0	1.5	2.0	2.5	3.0			
L035		250	-	-	-	-	-	-	-	-
L050		250	0.079	0.053	0.040	0.032	0.026	50	0.01	0.012
L070		250	0.181	0.121	0.091	0.072	0.060	114	0.01	0.012
L075		250	0.360	0.240	0.180	0.144	0.120	227	0.01	0.015
L090		250	0.636	0.424	0.318	0.254	0.212	401	0.01	0.018
L095		250	0.890	0.593	0.445	0.356	0.297	561	0.01	0.018
L099		250	1.257	0.838	0.629	0.503	0.419	792	0.01	0.022
L100		250	1.799	1.199	0.900	0.720	0.600	1134	0.01	0.022
L110		250	3.599	2.399	1.800	1.440	1.200	2268	0.01	0.030
L150		250	5.883	3.922	2.942	2.353	1.961	3708	0.01	0.033
L190		250	7.426	4.951	3.713	2.970	2.475	4680	0.01	0.040
L225		250	9.882	6.588	4.941	3.953	3.294	6228	0.01	0.044

NOTE: Angular misalignment is the difference between X and X max. Refer to Figure 2 above.

COUPLINGS

COUPLING SELECTION - SERVICE FACTORS FOR ELEMENT MATERIALS

NBR - (NITRILE BUTADIENE RUBBER)
ELEMENT MATERIAL

860 RPM MOTORS						1160 RPM MOTORS					
HP	Service Factors					HP	Service Factors				
	1.0	1.25	1.5	2.0	2.5		1.0	1.25	1.5	2.0	2.5
1/8	L050	L050	L050	L050	L050	1/8	L050	L050	L050	L050	L050
1/4	L050	L050	L070	L070	L075	1/4	L050	L050	L050	L070	L070
1/3	L050	L070	L070	L075	L075	1/3	L050	L050	L070	L070	L075
1/2	L070	L075	L075	L075	L090	1/2	L070	L070	L070	L075	L075
3/4	L075	L075	L075	L090	L090	3/4	L070	L075	L075	L075	L090
1	L075	L090	L090	L095	L095	1	L075	L075	L075	L090	L090
1 1/2	L090	L090	L095	L099	L099	1 1/2	L075	L090	L090	L095	L099
2	L095	L095	L099	L099	L100	2	L090	L090	L095	L099	L099
3	L099	L099	L100	L110	L110	3	L095	L099	L099	L100	L100
5	L100	L110	L110	L110	L150	5	L099	L100	L100	L110	L110
7 1/2	L110	L110	L150	L150	L190	7 1/2	L100	L110	L110	L150	L150
10	L110	L150	L150	L190	L225	10	L110	L110	L150	L150	L190
15	L150	L190	L190	L225	-	15	L150	L150	L150	L190	L225
20	L190	L225	L225	-	-	20	L150	L190	L190	L225	-
25	L225	L225	-	-	-	25	L190	L190	L225	-	-
30	L225	-	-	-	-	30	L190	L225	-	-	-
40	-	-	-	-	-	40	L225	-	-	-	-
50	-	-	-	-	-	50	-	-	-	-	-
60	-	-	-	-	-	60	-	-	-	-	-
75	-	-	-	-	-	75	-	-	-	-	-





NBR - ELEMENT MATERIAL

1750 RPM MOTORS						3500 RPM MOTORS					
HP	Service Factors					HP	Service Factors				
	1.0	1.25	1.5	2.0	2.5		1.0	1.25	1.5	2.0	2.5
1/8	L050	L050	L050	L050	L050	1/8	L035	L035	L035	L050	L050
1/4	L050	L050	L050	L050	L050	1/4	L050	L050	L050	L050	L050
1/3	L050	L050	L050	L050	L070	1/3	L050	L050	L050	L050	L050
1/2	L050	L050	L070	L070	L075	1/2	L050	L050	L050	L050	L050
3/4	L070	L070	L070	L075	L075	3/4	L050	L050	L050	L070	L070
1	L070	L075	L075	L075	L075	1	L050	L050	L070	L070	L075
1 1/2	L075	L075	L075	L090	L090	1 1/2	L070	L070	L070	L075	L075
2	L075	L075	L090	L090	L095	2	L070	L075	L075	L075	L075
3	L090	L090	L095	L099	L099	3	L075	L075	L075	L090	L090
5	L095	L099	L099	L100	L110	5	L075	L090	L090	L095	L099
7 1/2	L099	L100	L100	L110	L110	7 1/2	L090	L095	L099	L099	L100
10	L100	L110	L110	L110	L150	10	L095	L099	L099	L100	L110
15	L110	L110	L150	L150	L190	15	L099	L100	L100	L110	L110
20	L110	L150	L150	L190	L225	20	L100	L110	L110	L110	L150
25	L150	L150	L190	L225	L225	25	L110	L110	L110	L150	L150
30	L150	L190	L190	L225	-	30	L110	L110	L150	L150	L190
40	L190	L225	L225	-	-	40	L110	L150	L150	L190	L225
50	L225	L225	-	-	-	50	L150	L150	L190	L225	L225
60	L225	-	-	-	-	60	L150	L190	L190	L225	-
75	-	-	-	-	-	75	L190	L190	L225	-	-

COUPLING SELECTION - SERVICE FACTORS FOR ELEMENT MATERIALS CONTINUED

URETHANE - ELEMENT MATERIAL

860 RPM MOTORS						1160 RPM MOTORS					
HP	Service Factors					HP	Service Factors				
	1.0	1.25	1.5	2.0	2.5		1.0	1.25	1.5	2.0	2.5
1/8	L050	L050	L050	L050	L050	1/8	L050	L050	L050	L050	L050
1/4	L050	L050	L050	L050	L070	1/4	L050	L050	L050	L050	L050
1/3	L050	L050	L050	L070	L070	1/3	L050	L050	L050	L050	L070
1/2	L050	L070	L070	L075	L075	1/2	L050	L050	L070	L070	L075
3/4	L070	L075	L075	L075	L090	3/4	L070	L070	L070	L075	L075
1	L075	L075	L075	L090	L090	1	L070	L075	L075	L075	L075
1 1/2	L075	L090	L090	L095	L095	1 1/2	L075	L075	L075	L090	L090
2	L090	L090	L095	L095	L099	2	L075	L075	L090	L090	L095
3	L095	L095	L099	L099	L100	3	L090	L090	L095	L099	L099
5	L099	L099	L100	L110	L110	5	L095	L099	L099	L100	L110
7 1/2	L100	L110	L110	L110	L150	7 1/2	L099	L100	L100	L110	L110
10	L110	L110	L110	L150	L150	10	L100	L110	L110	L110	L150
15	L110	L150	L150	L190	L225	15	L110	L110	L150	L150	L190
20	L150	L150	L190	L225	-	20	L110	L150	L150	L190	L225
25	L150	L190	L225	-	-	25	L150	L150	L190	L225	L225
30	L190	L225	L225	-	-	30	L150	L190	L190	L225	-
40	L225	-	-	-	-	40	L190	L225	L225	-	-
50	-	-	-	-	-	50	L225	L225	-	-	-
60	-	-	-	-	-	60	L225	-	-	-	-
75	-	-	-	-	-	75	-	-	-	-	-
100	-	-	-	-	-	100	-	-	-	-	-
125	-	-	-	-	-	125	-	-	-	-	-
150	-	-	-	-	-	150	-	-	-	-	-

COUPLINGS



URETHANE - ELEMENT MATERIAL

1750 RPM MOTORS						3500 RPM MOTORS					
HP	Service Factors					HP	Service Factors				
	1.0	1.25	1.5	2.0	2.5		1.0	1.25	1.5	2.0	2.5
1/8	L050	L050	L050	L050	L050	1/8	L050	L050	L050	L050	L050
1/4	L050	L050	L050	L050	L050	1/4	L050	L050	L050	L050	L050
1/3	L050	L050	L050	L050	L050	1/3	L050	L050	L050	L050	L050
1/2	L050	L050	L050	L050	L070	1/2	L050	L050	L050	L050	L050
3/4	L050	L050	L070	L070	L075	3/4	L050	L050	L050	L050	L050
1	L050	L070	L070	L075	L075	1	L050	L050	L050	L050	L070
1 1/2	L070	L075	L075	L075	L075	1 1/2	L050	L050	L070	L070	L075
2	L075	L075	L075	L090	L090	2	L050	L070	L070	L075	L075
3	L075	L075	L090	L090	L095	3	L070	L075	L075	L075	L075
5	L090	L095	L095	L099	L099	5	L075	L075	L075	L090	L095
7 1/2	L095	L099	L099	L100	L110	7 1/2	L075	L090	L090	L095	L099
10	L099	L099	L100	L110	L110	10	L090	L095	L095	L099	L099
15	L100	L110	L110	L110	L150	15	L095	L099	L099	L100	L110
20	L110	L110	L110	L150	L150	20	L099	L099	L100	L110	L110
25	L110	L110	L150	L150	L190	25	L099	L100	L110	L110	L110
30	L110	L150	L150	L190	L225	30	L100	L110	L110	L110	L150
40	L150	L150	L190	L225	-	40	L110	L110	L110	L150	L150
50	L150	L190	L225	-	-	50	L110	L110	L150	L150	L190
60	L190	L225	L225	-	-	60	L110	L150	L150	L190	L225
75	L225	L225	-	-	-	75	L150	L150	L190	L225	L225
100	-	-	-	-	-	100	L150	L190	L225	-	-
125	-	-	-	-	-	125	L190	L225	L225	-	-
150	-	-	-	-	-	150	L225	L225	-	-	-

COUPLINGS

COUPLING SELECTION - SERVICE FACTORS FOR ELEMENT MATERIALS

CONTINUED

HYTREL - ELEMENT MATERIAL

860 RPM MOTORS						1160 RPM MOTORS					
HP	Service Factors					HP	Service Factors				
	1.0	1.25	1.5	2.0	2.5		1.0	1.25	1.5	2.0	2.5
1/8	L050	L050	L050	L050	L050	1/8	L050	L050	L050	L050	L050
1/4	L050	L050	L050	L050	L050	1/4	L050	L050	L050	L050	L050
1/3	L050	L050	L050	L050	L070	1/3	L050	L050	L050	L050	L050
1/2	L050	L050	L070	L070	L070	1/2	L050	L050	L050	L070	L070
3/4	L070	L070	L070	L070	L075	3/4	L050	L070	L070	L070	L070
1	L070	L070	L070	L075	L075	1	L070	L070	L070	L070	L075
1 1/2	L070	L075	L075	L075	L090	1 1/2	L070	L070	L075	L075	L075
2	L075	L075	L075	L090	L090	2	L070	L075	L075	L075	L090
3	L075	L090	L090	L095	L095	3	L075	L075	L090	L090	L095
5	L090	L095	L095	L099	L100	5	L090	L090	L095	L095	L099
7 1/2	L095	L099	L100	L100	L110	7 1/2	L095	L095	L099	L100	L100
10	L099	L100	L100	L110	L110	10	L095	L099	L100	L100	L110
15	L100	L110	L110	L110	L150	15	L100	L100	L110	L110	L110
20	L110	L110	L110	L150	L150	20	L100	L110	L110	L110	L150
25	L110	L110	L150	L150	L190	25	L110	L110	L110	L150	L150
30	L110	L150	L150	L190	L225	30	L110	L110	L150	L150	L190
40	L150	L150	L190	L225	-	40	L110	L150	L150	L190	L225
50	L150	L190	L225	-	-	50	L150	L150	L190	L225	-
60	L190	L225	-	-	-	60	L150	L190	L225	-	-
75	L225	-	-	-	-	75	L190	L225	L225	-	-
100	-	-	-	-	-	100	L225	-	-	-	-
125	-	-	-	-	-	125	-	-	-	-	-
150	-	-	-	-	-	150	-	-	-	-	-
200	-	-	-	-	-	200	-	-	-	-	-
250	-	-	-	-	-	250	-	-	-	-	-
300	-	-	-	-	-	300	-	-	-	-	-

COUPLINGS



HYTREL - ELEMENT MATERIAL

1750 RPM MOTORS						3500 RPM MOTORS					
HP	Service Factors					HP	Service Factors				
	1.0	1.25	1.5	2.0	2.5		1.0	1.25	1.5	2.0	2.5
1/8	L050	L050	L050	L050	L050	1/8	L050	L050	L050	L050	L050
1/4	L050	L050	L050	L050	L050	1/4	L050	L050	L050	L050	L050
1/3	L050	L050	L050	L050	L050	1/3	L050	L050	L050	L050	L050
1/2	L050	L050	L050	L050	L050	1/2	L050	L050	L050	L050	L050
3/4	L050	L050	L050	L070	L070	3/4	L050	L050	L050	L050	L050
1	L050	L050	L070	L070	L070	1	L050	L050	L050	L050	L050
1 1/2	L070	L070	L070	L070	L075	1 1/2	L050	L050	L050	L070	L070
2	L070	L070	L070	L075	L075	2	L050	L050	L070	L070	L070
3	L070	L075	L075	L075	L090	3	L070	L070	L070	L070	L075
5	L075	L075	L090	L090	L095	5	L070	L070	L075	L075	L075
7 1/2	L090	L090	L095	L095	L099	7 1/2	L075	L075	L075	L090	L090
10	L090	L095	L095	L099	L100	10	L075	L075	L090	L090	L095
15	L095	L099	L100	L100	L110	15	L090	L090	L095	L095	L099
20	L099	L100	L100	L110	L110	20	L090	L095	L095	L099	L100
25	L100	L100	L110	L110	L110	25	L095	L095	L099	L100	L100
30	L100	L110	L110	L110	L150	30	L095	L099	L100	L100	L110
40	L110	L110	L110	L150	L150	40	L099	L100	L100	L110	L110
50	L110	L110	L150	L150	L190	50	L100	L100	L110	L110	L110
60	L110	L150	L150	L190	L225	60	L100	L110	L110	L110	L150
75	L150	L150	L190	L225	-	75	L110	L110	L110	L150	L150
100	L150	L190	L225	-	-	100	L110	L110	L150	L150	L190
125	L190	L225	-	-	-	125	L110	L150	L150	L190	L225
150	L225	-	-	-	-	150	L150	L150	L190	L225	-
200	-	-	-	-	-	200	L150	L190	L225	-	-
250	-	-	-	-	-	250	L190	L225	-	-	-
300	-	-	-	-	-	300	L225	-	-	-	-

COUPLINGS