

XT HUBS



Usage: XT hubs are for use with the XT Bushing.

DID YOU KNOW THAT...

- 2"/ft. taper for easy on, easy off
- Made of low carbon steel for its excellent welding properties

HOW TO ORDER

EXAMPLE: **XTH20**

XTH **20**

XTH: XT HUB

20: HUB SIZE
 Related to the XT bushing

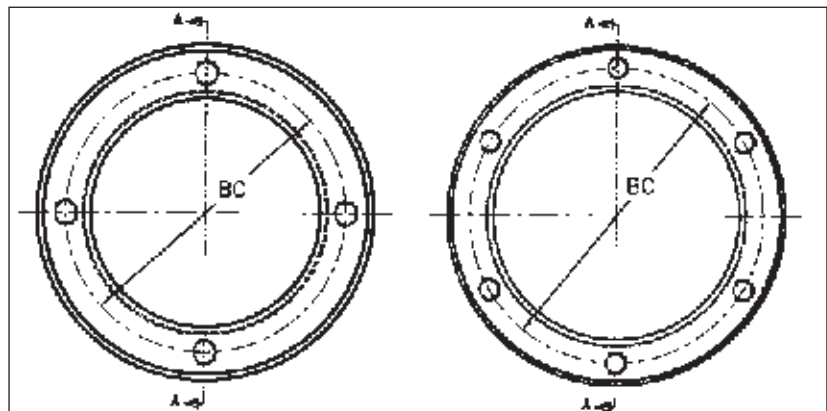

XTH15 to XTH80
Inclusive

XTH100

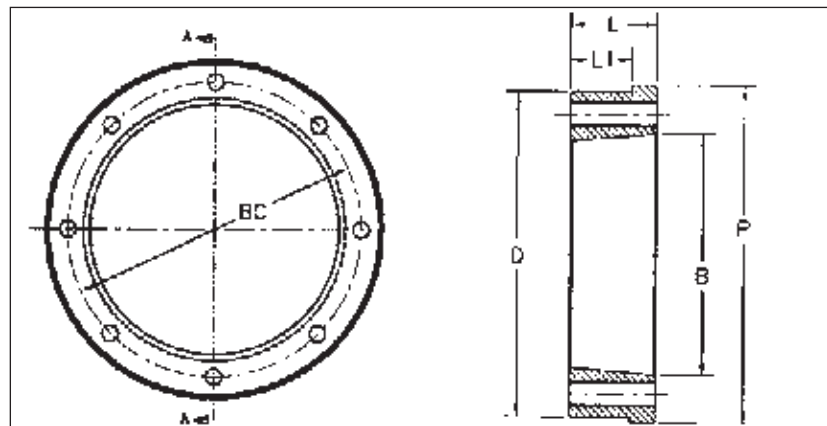

XTH120

Section A-A
Taper 2" per ft.
on Diameter -B-

DIMENSIONS

BUSHINGS & HUBS

Hub No.	List Price \$	Fits Bushing	Dimensions - Inches						Tapped Holes		Approx. Weight
			D*	L	B	P	L ₁	BC	No.	Size	
XTH15	8.00	XTB15	2.875	5/8	2.000	3.190	7/16	2 7/16	4	1/4-20NC	0.7
XTH20	15.00	XTB20	3.813	13/16	2.688	4.065	9/16	3 3/16	4	5/16-18NC	1.5
XTH25	25.00	XTB25	4.375	1 1/8	3.188	4.690	13/16	3 3/4	4	3/8-16NC	2.6
XTH30	43.00	XTB30	5.750	1 1/4	3.875	5.940	7/8	4 9/16	4	7/16-14NC	4.1
XTH35	55.00	XTB35	6.345	1 1/2	4.688	6.565	1 1/16	5 7/16	4	1/2-13NC	6.6
XTH40	85.00	XTB40	7.250	1 3/4	5.313	7.563	1 1/4	6 1/8	4	9/16-12NC	10.7
XTH45	109.00	XTB45	8.000	2 1/8	5.938	8.315	1 1/2	6 7/8	4	5/8-11NC	15.4
XTH50	173.00	XTB50	9.563	2 1/2	7.250	9.940	1 3/4	8 5/16	4	3/4-10NC	24.9
XTH60	267.00	XTB60	11.250	2 3/4	8.625	11.690	1 15/16	9 7/8	4	7/8-9NC	36.4
XTH70	334.00	XTB70	13.188	3 1/8	10.000	13.628	2 3/16	11 9/16	4	1-8NC	57.7
XTH80	425.00	XTB80	14.625	3 7/16	11.125	14.940	2 7/16	12 7/8	4	1 1/8-7NC	75.6
XTH100	699.00	XTB100	17.500	4 1/8	13.688	17.940	3	15 9/16	6	1 1/8-7NC	122
XTH120	1059.00	XTB120	20.500	4 13/16	16.188	20.940	3 1/2	18 3/16	8	1 1/8-7NC	189

* Tolerance: (+0.000"/-0.005")

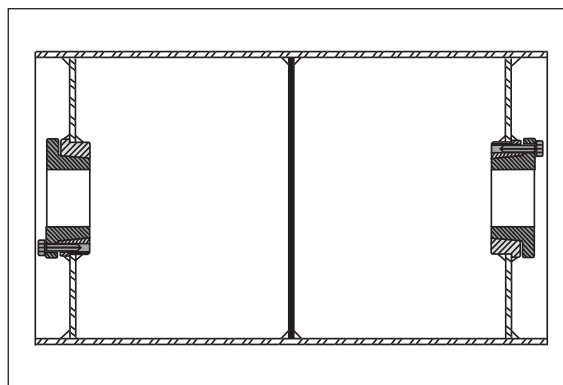

Conveyor Drum Application