

XT BUSHINGS

Usage: Bushing sizes 15-45 are made of steel. This product is specially designed for conveyor pulley applications.



DID YOU KNOW THAT...

- 2"/ft. taper for easy on, easy off
- In steel & gray cast iron

IMPORTANT REMINDER



For the first month of operation, inspect bushings and capscrews for proper seating at least once a week and thereafter during periodic shut down.

HOW TO ORDER

EXAMPLE: **XTB20X2**

XTB

20

X2

XTB: XT BUSHING

20: BUSHING SIZE

Means that the maximum bore for this bushing is 2.0"

X2: BORE SIZE (2")

Inch bore sizes are designated with the whole inch following by fraction. For example, a 1.5" diameter bore would be 1-1/2.

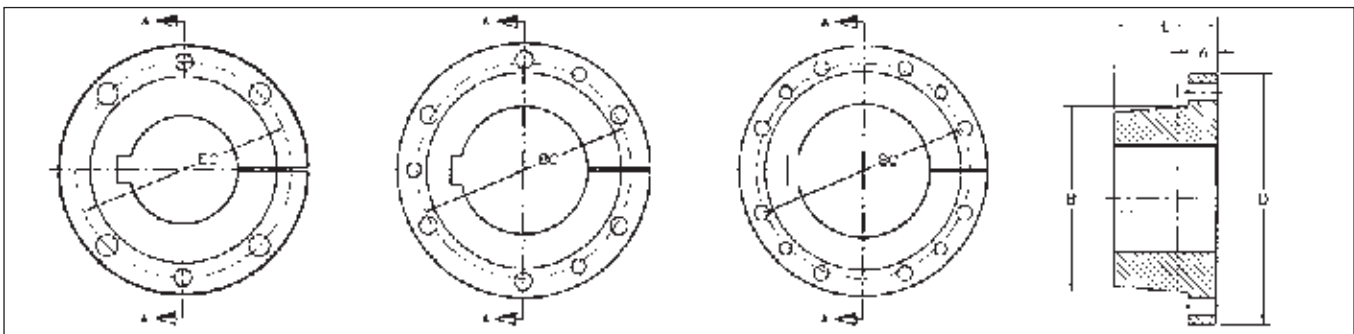

XTB15 TO XTB80
INCLUSIVE

XTB100

XTB120

SECTION A-A
Taper 2" per ft.
on diameter -B-

DIMENSIONS

Bushing Size	List Price \$	Dimensions - Inches					No.	Size	Recommended Wrench Torque (ft-lbs)	Approx. Weight
		A	B	D	L	BC				
XTB15	16.00	3/8	2.000	2 7/8	1 1/8	2 7/16	4	1/4-20NC x 1"	7.9	0.7
XTB20	33.00	15/32	2.688	3 3/4	1 13/32	3 3/16	4	5/16-18NC x 1-1/4"	16.7	1.5
XTB25	58.00	5/8	3.188	4 7/16	1 7/8	3 3/4	4	3/8-16NC x 1 3/4"	29.2	2.6
XTB30	87.00	11/16	3.875	5 5/16	2 1/16	4 9/16	4	7/16-14NC x 1 1/2"	45.8	4.2
XTB35	139.00	25/32	4.688	6 5/16	2 15/32	5 7/16	4	1/2-13NC x 1 3/4"	70	7.4
XTB40	190.00	7/8	5.313	7 1/8	2 13/16	6 1/8	4	9/16-12NC x 2"	100	10.5
XTB45	271.00	15/16	5.938	8	3 5/16	6 7/8	4	5/8-11NC x 2-1/4"	140	14.8
XTB50	490.00	1	7.250	10 1/8	3 3/4	8 5/16	4	3/4-10NC x 2 1/2"	250	27.8
XTB60	673.00	1 1/8	8.625	11 15/16	4 1/8	9 7/8	4	7/8-9NC x 2-1/2"	400	42.8
XTB70	887.00	1 5/16	10.000	13 15/16	4 11/16	11 9/16	4	1-8NC x 3"	600	66.3
XTB80	1719.00	1 3/8	11.125	15 5/8	5 1/8	12 7/8	4	1 1/8-7NC x 3 1/2"	750	85.7
XTB100	2243.00	1 9/16	13.688	17 15/16	6 3/16	15 9/16	6	1 1/8-7NC x 3 1/2"	750	146
XTB120	3194.00	1 3/4	16.188	20 5/8	7 1/16	18 3/16	8	1 1/8-7NC x 3 1/2"	750	216

BUSHINGS & HUBS

STANDARD STOCK BORES

Bushing	Stock Bore	Keyseat
XTB15	5/8 · 3/4 · 7/8 1 · 1 1/8 · 1 3/16 1 1/4 1 7/16 · 1 1/2	3/16 x 3/32 1/4 x 1/8 1/4 x 1/8 3/8 x 1/8*
XTB20	3/4 1 · 1 3/16 · 1 1/4 1 7/16 · 1 1/2 1 11/16 1 15/16 · 2	3/16 x 3/32 1/4 x 1/8 3/8 x 3/16 3/8 x 3/16 1/2 x 3/16*
XTB25	1 · 1 3/16 · 1 1/4 1 7/16 · 1 1/2 · 1 11/16 1 15/16 · 2 · 2 3/16 2 7/16	1/4 x 1/8 3/8 x 3/16 1/2 x 1/4 5/8 x 1/8*
XTB30	1 7/16 · 1 1/2 1 15/16 · 2 3/16 2 7/16 · 2 11/16 2 15/16	3/8 x 3/16 1/2 x 1/4 5/8 x 5/16 3/4 x 3/16*
XTB35	1 15/16 · 2 3/16 2 7/16 · 2 11/16 2 15/16 3 7/16	1/2 x 1/4 5/8 x 5/16 3/4 x 3/8 7/8 x 5/16*

Bushing	Stock Bore	Keyseat
XTB40	2 7/16 2 15/16 3 7/16 3 15/16	5/8 x 5/16 3/4 x 3/8 7/8 x 7/16 1 x 3/8*
XTB45	3 7/16 3 15/16 4 7/16	7/8 x 7/16 1 x 1/2 1 x 3/8*
XTB50	3 15/16 · 4 7/16 4 15/16	1 x 1/2 1 1/4 x 5/8
XTB60	5 7/16 · 5 1/2 5 15/16 · 6	1 1/4 x 5/8 1 1/2 x 3/4
XTB70	6 7/16 · 6 1/2 6 15/16 · 7	1 1/2 x 3/4 1 3/4 x 3/4
XTB80	7 1/2 7 15/16 · 8	1 3/4 x 3/4 2 x 3/4
XTB100	8 1/2 · 9 9 7/16 · 9 1/2 · 10	2 x 3/4 2 1/2 x 7/8
XTB120	10 1/2 · 11 11 1/2 · 12	2 1/2 x 7/8 3 x 1

* Key provided with these sizes only.
XTB50-XTB120 made from gray cast iron.