

**OPERATOR'S MANUAL
FOR YOUR**

BALDOR® GENERATORS

AUTOMATIC EMERGENCY MODEL AE8/10



BALDOR GENERATORS
3815 Oregon Street • Oshkosh WI 54902
Telephone 236-4200 • Fax 920-236-4219

FORM#: S-PSG-002-5
EFFECTIVE DATE: 4/2/97
AE8/10 COVER \MSW'00

REVISION DATE: 10/14/02

FORWARD

This manual contains the information you need to safely and efficiently operate your generator set. During the preparation of this manual every effort was made to ensure the accuracy of its contents.

Never operate this generator set without first carefully reading this manual and observing all the safety warnings it presents. While safety is built into every Baldor Pow'R Gard generator set, careless or improper operation could possibly result in mechanical failure, property damage, severe injury or death.

Note that this manual covers only very basic information in regards to the engine. A separate owner's manual for the engine is supplied with this unit for your use. Please refer to this manual for information relative to engine operation, maintenance, recommendations and additional safety warnings.

As soon as you receive your generator set, inspect it closely for shipping damage. If you find some damage, notify the transportation company immediately and file a freight damage claim.

Think of this manual as a tool to help you get the most out of your generator set. We strongly suggest that you keep this manual with your generator set and refer to it when questions arise in regards to its operation.

Baldor Generators, formerly Pow'R Gard Generator Corporation has been in business since 1965. The generator sets we manufacture have earned the reputation of being of high quality and a dependable product. We take pride in this fact and continue to keep our quality standards high on our list of priorities. We are also constantly researching new technological ideas to determine if they could be used to make our generator sets even better.

Thank you for purchasing your Baldor Pow'R Gard Generator Set.

**WARNING****IMPROPER MAINTENANCE OR REPAIR CAN RESULT IN PROPERTY DAMAGE, MECHANICAL FAILURE, SEVERE INJURY OR DEATH!**

Place protective covers and guards over the rotating parts, if rotating parts such as the drive shaft, pulley, belt, etc. are left exposed, they are potentially hazardous.



When cleaning, repairing or inspecting, make sure all moving parts have stopped.



Prior to working on the generator set, disconnect the spark plug and battery to prevent accidental starting.



Use only original equipment or authorized replacement parts. Use of correct parts will assure the operator of the safety integrity that was designed into the unit.



Unauthorized modifications to the generator set may impair the function and/or safety of the unit.



Do not operate the generator set without a muffler. Inspect periodically and replace if necessary.



Do not touch the hot exhaust components or the high voltage spark plug and coil terminals. While Spark Plug Voltages are not normally lethal, an involuntary jerk of the hand caused by a hot surface or by an electrical shock can result in injury.



Repair of electrical generating equipment requires specialized skills. Repair personnel must have a thorough understanding of generator and small engine repair procedures.

**WARNING****EXHAUST FUMES/GASES ARE EXTREMELY DANGEROUS AND CAN CAUSE ILLNESS OR DEATH.**

Never inhale exhaust gases. They contain carbon monoxide; a colorless, odorless and extremely dangerous gas that can cause unconsciousness or death!



Symptoms of carbon monoxide poisoning can include: dizziness, nausea, headaches, sleepiness, vomiting or incoherency. If you or anyone else experiences any of these symptoms, get out into the fresh air immediately. Shut the unit down and do not operate it until it has been inspected and, if necessary, repaired.



Never Operate the generator set indoors or in a poorly ventilated area such as a tunnel or cave.



CALIFORNIA PROPOSITION 65 WARNING: engine exhaust from this product contains chemicals known to the state of California to cause cancer, birth defects or other reproductive harm.



WARNING



IMPROPER OPERATION CAN RESULT IN PROPERTY DAMAGE, MECHANICAL FAILURE, SEVERE INJURY OR DEATH!



Know how to stop the engine quickly and understand the operation of all controls.



Never permit anyone to operate the generator set without proper instructions.



Never allow children to operate the generator set.



Children and pets must be kept away from the area of operation due to the possibility of burns from hot engine components or injury from any equipment the generator set is powering.



Always wear eye protection and Hearing protection when working near the generator set.



Operate the generator set only with the guards, shields and other safety items in place and working properly.



Do not put hands, feet, tools or other objects near rotating parts.



Use reasonable care when moving or lifting the unit. The generator set may move around inside the wrap frame creating "Pinch Points".



Do not run the generator set while it is being moved.



Do not support the generator set from the top of the wrap frame.



Do not operate the generator set while under the influence of alcohol, drugs or medication.



When transporting or using a generator set with optional Dolly Kit, secure the unit to prevent it from moving around.



Do not tamper with or change the engine speed as it has been preset at the factory for proper operation.



Keep hands and face away from the carburetor when the air cleaner is being moved. A sudden backfire can cause serious burns.



Be careful of hot parts. The muffler and other generator parts become very hot while the engine is running.



Do not "jump start" the generator set.



Sulfuric acid can cause severe injury and can give off gases, which are corrosive and potentially explosive. Avoid contact with skin, eyes, and clothing. In case of contact, flush area immediately with water.



When transporting a generator set, secure it to prevent it from moving or shifting.



WARNING



THIS GENERATOR SET PRODUCES ELECTRICITY AND WITH THAT THERE IS THE POTENTIAL DANGER FOR ELECTROCUTION.



Know how to stop the engine quickly and understand the operation of all controls.



Do not operate electrical equipment while standing in water, on wet ground or with wet hands or shoes.



Use extreme caution when working on electrical components. Potentially dangerous voltage is present when the engine is running.



Always treat the electrical circuits as if they were energized.



Disconnect all leads plugged into the unit Prior to working on it.



Have the electrical circuits serviced only by qualified technicians.



Inspect wiring frequently and replace frayed, broken or poor leads.



Do not connect this unit to any building's electrical system unless you utilize an approved transfer switch or the main service entrance switch has been disconnected and locked open.



Circuit overload protection must be provided in accordance with national electrical codes and local regulations.













Check GFCI Receptacles monthly by using the "Test" and "Reset" buttons designed into them.



Depending on your application it may be mandatory to ground or not ground this unit to earth ground. Comply with local electrical codes.



○ ○ ○ **FOR GASOLINE OR DIESEL POWERED GENERATOR SETS** ○ ○ ○



 WARNING 	GASOLINE AND DIESEL FUEL ARE FLAMMABLE AND CAN CAUSE EXPLOSIONS, FIRE, INJURY OR DEATH!
------------------------------------------------------------------------------------------------------------------------------------------------------------------------------------	------------------------------------------------------------------------------------------------

-  Operate the generator set on a level surface. If the generator set is tilted, fuel spillage may result.
-  Handle fuel with care. It is highly flammable. Use only clean, properly marked and approved safety containers for refueling and storing fuel.
-  Stop the engine and allow it to cool before refueling.
-  Do not overfill the fuel tank. Only fill the tank to within 1/2" of the top of the tank to allow space for fuel expansion.
-  If fuel is spilled, wipe it up carefully and wait until the fuel has dried before starting the engine.
-  Make sure the fuel cap is properly closed after refueling.
-  Never operate the generator set while smoking.
-  Never operate the generator set near an open flame.
-  When transporting over long distances or rough roads, drain the fuel tank to prevent leakage and spillage.
-  Never store the generator set with fuel in the tank indoors or in an enclosed, poorly ventilated enclosure where fuel fumes may reach an open flame, electrical spark or pilot light as on a furnace, water heater, clothes dryer, etc.

 WARNING 	GASEOUS FUELS ARE HIGHLY COMBUSTIBLE AND CAN CAUSE EXPLOSIONS, FIRE, INJURY OR DEATH!
----------------------------------------------------------------------------------------------------------------------------------------------------------------------------------------	----------------------------------------------------------------------------------------------

○ ○ ○ **FOR GASOLINE OR DIESEL POWERED GENERATOR SETS** ○ ○ ○

-  Check all fuel supply piping and their connections on a monthly basis for fuel leaks.
-  Use only approved piping and componentry in your fuel supply system.

-  A professional, experienced technician should only install the fuel supply system.
-  Do not run the fuel line up against any sharp objects.
-  Comply with NFPA regulations and your local codes in regard to shut-off valves, regulators, etc. and any other recommendations or requirements they may have.

 WARNING 	THIS GENERATOR SET CREATES A SIGNIFICANT AMOUNT OF HEAT AND IF NOT HANDLED PROPERLY CAN BECOME A SUBSTANTIAL FIRE HAZARD.
------------------------------------------------------------------------------------------------------------------------------------------------------------------------------------	----------------------------------------------------------------------------------------------------------------------------------









-  Keep the generator set at least three feet away from buildings or other structures.
-  Keep the generator set away from flammable and other hazardous materials (trash, rags, lubricants, explosives, paints, etc.)
-  Keep the generator set free of grass, leaves and excessive grease and oils.
-  Allow the generator set to cool before transporting it or storing it indoors.
-  Have fire extinguisher accessible and nearby while operating the generator set.
-  This generator set must not be used on or near any forest covered brush covered or grass covered land unless the engine's exhaust system is equipped with a spark arrester and it must be maintained in effective working order by the owner/operator.
-  Operation inside an enclosed compartment or building is a potential fire hazard and should not be done unless approval is obtained from Baldor Generators. Engine/Generator overheating can cause severe damage due to restricted, obstructed or improper air-flow that is necessary for the proper cooling of the unit.
-  Hot exhaust gases being discharged by the engine must never be directed toward anything that could catch fire or explode.

TABLE OF CONTENTS

<u>SECTION</u>	<u>PAGE</u>
Generator Specifications	10
Location Information	11
Connection Information	12
Engine Information	14
Basic Generator Maintenance	15
Basic Engine Maintenance	16
Storage or Long Term Non-Use Instructions	17
Parts & Service Information	18
General Installation & Site Selection Guidelines	19
Electric Installation Guidelines	21
AE8/10 Enclosed Assembly Diagram.....	24
AE8 / 10 Installation Diagram	25
Basic Gaseous Fuel Information.	26
Propane Gas Flow Chart	30
Natural Gas Flow Chart.	31
Operation	32
Simple Electrical Troubleshooting	34
Gaseous Fuel System Troubleshooting	36
Electrical System Troubleshooting	39
AE Series Interconnection	41
<u>Appendixes</u>	
Wiring Diagrams	
Parts Lists	
Baldor Warranty Information	

THIS PAGE INTENTIONALLY LEFT BLANK

SPECIFICATIONS FOR YOUR AE8 BALDOR GENERATOR SET

RATINGS: 8 KW FUEL TYPE: LP/Natural Gas ELECTRICAL CHARACTERISTICS: Voltage: 120/240 Phase: 1 Power Factor: 1 Amps: 66.7/33.4 Hertz: 60 Voltage Regulation (+/-): 5% Frequency Regulation: 5% Total Harmonic Distortion: C/F Motor Starting (HP): 3	ENGINE CHARACTERISTICS: Make: VANGARD Model: 303447 Cooling: Air No. Cylinders 2 H.P. 16.0 R.P.M.: 3600 FUEL CONSUMPTION (Full Load): LP Gas: 64 C.F.H Natural Gas: 160 C.F.H.
Dimensions w/ enclosure - IN. (LxWxH) : 28 x 21^{1/2} x 21 Weight: 232 Lbs. Dimensions w/o enclosure - IN. (LxWxH) : 44^{1/2} x 29 x 36^{3/4} Weight: 445 Lbs.	

SPECIFICATIONS FOR YOUR AE10 BALDOR GENERATOR SET

RATINGS: 10 KW FUEL TYPE: LP/Natural Gas ELECTRICAL CHARACTERISTICS: Voltage: 120/240 Phase: 1 Power Factor: 1 Amps: 83.3/41.7 Hertz: 60 Voltage Regulation (+/-): 1% Frequency Regulation: 5% Total Harmonic Distortion: <8% Motor Starting (HP): 4	ENGINE CHARACTERISTICS: Make: VANGARD Model: 350447 Cooling: Air No. Cylinders 2 H.P. 18.0 R.P.M.: 3600 FUEL CONSUMPTION (Full Load): LP Gas: 72 C.F.H Natural Gas: 200 C.F.H.
Dimensions w/ enclosure - IN. (LxWxH) : 30 x 23 x 22^{1/4} Weight: 276 Lbs. Dimensions w/o enclosure - IN. (LxWxH) : 44^{1/2} x 29 x 36^{3/4} Weight: 455 Lbs.	

NOTE: The enclosed information covers basic installation, operating and maintenance for this specific generator.

Installation of this generator is the sole responsibility of the owner.

Baldor provides an AE Installation manual with the shipment of your generator which contains more specific information regarding the installation of your AE Unit.

Any questions regarding this information may be directed to the service department at Baldor Generators.

This information is designed to be a guide for an experienced electrician. Those not qualified should not attempt installation.

LOCATION

The following information is provided to assure that you get the best service from your Automatic Emergency Generator. Several factors should be taken into consideration in choosing the best location in which to permanently mount this unit.

SURFACE: Baldor generators strongly recommends that your AE Unit be installed on a concrete or cement slab of appropriate size relative to the generator's base which is at least five (5) feet from any building, structure, shrubbery, or any other obstruction that could possibly catch fire due to the extreme heat output of this generator set.

MOISTURE: All electrical equipment should be protected from excessive moisture. Failure to do so will result in deterioration of the wiring insulation and may result in short circuits and a possible electrocution hazard.



OPERATING ELECTRICAL EQUIPMENT IN WET ENVIRONMENTAL CONDITIONS CREATES A POTENTIAL ELECTROCUTION HAZARD. DO NOT OPERATE ELECTRICAL EQUIPMENT WHILE STANDING IN WATER, ON WET GROUND, OR WITH WET HANDS OR SHOES.

DIRT: Foreign materials such as dust, sand, and other abrasive materials have a tendency to cause excessive wear to both engine and generator parts. It is important that the unit be permanently located and operated in a reasonable clean environment.

HEAT: All engines give off considerable heat when running. Since the engine and your generator set uses air to keep it cool it is important that the temperature of the area in which it is located does not exceed 100 degrees F (Even while it is running). Where natural ventilation is inadequate, a fan to boost circulation should be utilized.

EXHAUST: Exhaust gases from internal combustion engines are extremely poisonous. We recommend that this unit not be placed in an indoor environment. However, if this is the application you choose, the engine exhaust fumes must be vented to the outside.



EXHAUST FUMES CAN CAUSE SEVERE INJURY OR DEATH. ALWAYS OPERATE IN A WELL VENTILATED AREA.

CONFINED SPACE: This unit must not be operated in a confined space or an enclosed compartment/area. Running the generator set in this environment is a potential fire hazard and is not authorized. Engine and generator overheating damage could also occur due to restricted cooling air flow to and from the unit.



OPERATING THIS UNIT IN AN AREA WITHOUT ADEQUATE VENTILATION CREATES A POTENTIAL FIRE HAZARD. ALWAYS OPERATE THIS UNIT IN A WELL VENTILATED AREA.

CONNECTION INFORMATION

Your new Baldor Generator has all interconnecting wiring, which is terminated at a junction box. All wiring will be clearly labeled as being load, remote start contacts, and AC input terminals and are to be connected as described below:

LOAD - These connections are rated and sized according to the KW of the generator. Proper lead wire from these points to the automatic transfer switch (or load switching device) is mandatory. See enclosed transfer switch information for corresponding generator input terminals.

WIRING - Use sufficiently large insulated wire to connect the generator set to the load. The gauge of wire will depend largely on the distance, the permissible voltage drop, and the size and type of load. **If you are not sure of the gauge wire needed for your application, consult a competent electrician.**



FRAYED, CUT, BROKEN, LOOSELY CONNECTED, OR IMPROPERLY SIZED POWER CORDS OR WIRES CAN CAUSE EQUIPMENT DAMAGE, FIRE, SEVERE INJURY OR DEATH. INSPECT AND MAINTAIN ALL POWER CORDS ON A REGULAR BASIS.

REMOTE START CONTACTS - This two wire connection, once connected to an appropriate switch will start the generator and perform as described in the remote start/stop literature. These contacts are connected to the "Engine Start Contacts" of the automatic transfer switch.

A Two Pole normally open, closed to operate switch may also be used to start the generator.

AC INPUT - These connections are for units with float type battery chargers or engine block heater combinations. A constant supply of 120 volts AC (or as specified) is needed at these terminals to power these devices.

NOTE - Power is not required when the unit is in operation. Internal battery charging and radiant heat during operation eliminate the need for these devices.

NOTE - It is recommended that units utilizing an automatic transfer switch with adjustable time delay have the initial adjustments made prior to startup.

Factory recommendations are to allow a 2 second delay on startup, and a 15 second delay on emergency to normal (so if your public service power is interrupted, the automatic transfer switch will tell your generator to start after two seconds of power loss. Then, once Public Service Power is restored, the generator will continue to operate for an additional fifteen minutes just in case there is yet another outage of power).

GROUNDING: If grounding is necessary in your application according to National Electric Code and/or local codes, drive a 3/4" or 1" pipe into the ground as close to the Generator Set as is possible. This pipe must penetrate moist earth (minimum of 8 feet). Connect a ground clamp to this pipe and run a No. 10 wire or larger from it to the ground stud on the generator set.

Do not connect the ground wire from the generator set to a water pipe or a ground used by a radio system.



IMPROPER GROUNDING CAN CAUSE EQUIPMENT DAMAGE, SEVERE INJURY OR DEATH. INSPECT AND MAINTAIN THE GROUNDING SYSTEM IN ACCORDANCE WITH ALL APPLICABLE CODES.

CONNECTIONS TO HOUSE WIRING: Any electrical generator that is temporarily connected to a building or home (where the building is also supplied electricity by a local utility) shall be connected **only by a competent electrician and only after the main service entrance switch has been disconnected and locked open**. This will isolate the building's electrical system from the local utility's electrical transmission wires and prevent the hazard of electrical back-feed to utility service workers.

Any generator set that is permanently connected to a building or home (where the building is also supplied electricity by a local utility) shall be connected only by means of a double-throw transfer switch. This will isolate the building's electrical system from the local utility's electrical transmission wires and prevent the hazard of electrical back-feed to utility service workers.



DO NOT CONNECT THIS GENERATOR SET TO ANY BUILDING'S ELECTRICAL SYSTEM UNLESS YOU USE AN APPROVED TRANSFER SWITCH OR THE MAIN SERVICE ENTRANCE SWITCH HAS BEEN DISCONNECTED AND LOCKED OPEN.



ANY TEMPORARY OR PERMANENT WIRING CONNECTIONS MADE BETWEEN GENERATOR SET AND AN EXISTING ELECTRICAL SYSTEM MUST ONLY BE DONE BY A QUALIFIED COMPETENT ELECTRICIAN. IMPROPER WIRING/ CONNECTIONS COULD CAUSE EQUIPMENT DAMAGE, PROPERTY DAMAGE, INJURY OR DEATH.

CHECK ALL NATIONAL ELECTRIC CODES AND ALL LOCAL CODES IN REGARDS TO YOUR SPECIFIC APPLICATION. ANY NATIONAL ELECTRIC CODE OR LOCAL CODE WILL TAKE PRECEDENCE OVER ANY OF OUR GUIDELINES OR RECOMMENDATIONS.

ENGINE INFORMATION

This operator's manual only covers basic day -to -day engine operating instructions. However, the engine manufacturer's manual is included with your generator set and should be referred to for any additional information you may need. Become familiar with and follow all the engine manufacturer's operation, safety and maintenance guidelines.

OIL: Use a high quality oil of the type specified in the engine owner's manual for your specific operating conditions. Check the oil regularly, or at minimum every 5-8 hours of operation.



TO HELP PREVENT ENGINE DAMAGE, CHECK THE OIL LEVEL OF THE ENGINE REGULARLY AND MAKE SURE IT IS MAINTAINED AT THE PROPER LEVEL.

FUEL: (LP or Natural Gas): Make sure the gaseous fuel being supplied to the unit is in vapor form and that it is being delivered to the engine's gaseous fuel regulator at the pressure specified on it.

An engine needs 10,000 BTU's of fuel per each engine horsepower to operate properly.



GASEOUS FUEL IS EXTREMELY FLAMMABLE AND CAN CAUSE PROPERTY DAMAGE, SEVERE INJURY OR DEATH. CHECK THE GASEOUS FUEL SUPPLY SYSTEM ON A MONTHLY BASIS FOR LEAKS. HAVE ANY LEAKS REPAIRED BY AN EXPERIENCED PROFESSIONAL PRIOR TO STARTING YOUR GENERATOR SET.

OPERATING SPEED: This generator set must be run at it's proper designed speed in order to obtain the electrical power it was built to produce.

All engines have a tendency to slow down when a load is applied to it. The governor on the engine is designed to hold the operating speed as nearly constant as possible. When the load connected to the generator set is increased, the engine is more heavily loaded and as a result the engine speed drops slightly. This slight decrease in engine speed results in a slight decrease in generator voltage and frequency output. This voltage and frequency variation has no appreciable effect in the operation of motors, lights, and most appliances and tools. However, timing devices and clocks will not keep perfect time when used on this generator.

MAINTENANCE



MAINTENANCE SHOULD ONLY BE PERFORMED ON THE GENERATOR SET AFTER THE ENGINE HAS STOPPED AND THE GENERATOR SET HAS COOLED DOWN. THE BATTERY AND SPARK PLUG SHOULD ALSO BE DISCONNECTED PRIOR TO PERFORMING MAINTENANCE.

GENERATOR END MAINTENANCE

Generator end maintenance consists of cleaning the generator set, inspecting the wiring and fuel system, and making any necessary adjustments. Generator end maintenance should be performed on a monthly basis (or sooner if needed).

CLEANING:

- ✓ Clean the generator set and remove any and all dust, dirt, or other foreign material.
- ✓ Inspect and clean the cooling air intake and exhaust louvers of the generator end. Make sure they are free of 'caked -on' dirt or any other material that may restrict the cooling air flow through the generator windings.
- ✓ Clean the generator set and its components with a damp cloth or sponge.

Do not use sprayed water or compressed air to clean the generator set or it's components.

INSPECTING:

- ✓ Inspect the external wires of the generator set for cuts, fraying, or loose connections. Repair or replace any problems prior to using the unit.



CUT, FRAYED, BROKEN, OR LOOSELY CONNECTED WIRES CAN CAUSE EQUIPMENT DAMAGE, SEVERE INJURY, OR DEATH.

- ✓ Inspect and clean the battery posts and the associated battery cable terminals.
- ✓ Inspect and replace any control box components that are broken or not working properly (receptacles, circuit breakers, switches, etc...).
- ✓ Inspect the fuel system for leaks.
- ✓ Inspect and replace any fuel line that shows signs of deterioration.
- ✓ Make sure all the fuel clamps are tight.
- ✓ Make sure the fuel cap fits snugly on the fuel tank and that the fuel tank contains no leaks.



REPAIR ANY FUEL SYSTEM LEAKS PRIOR TO RUNNING THE UNIT.

ADJUSTMENTS:

- ✓ The engine should be checked for proper speed setting(s).
- ✓ Adjust the engine speed to 3720 RPM's (62 Hz) with no load applied to the generator set.

ENGINE MAINTENANCE



MAINTENANCE SHOULD ONLY BE PERFORMED ON THE GENERATOR SET AFTER THE ENGINE HAS STOPPED AND THE GENERATOR SET HAS COOLED DOWN. THE BATTERY AND SPARK PLUG SHOULD ALSO BE DISCONNECTED PRIOR TO PERFORMING MAINTENANCE.



REPAIRS AND/OR ANY ADJUSTMENTS MADE TO THE GENERATOR SET SHOULD ONLY BE PERFORMED BY A COMPETENT MECHANIC FAMILIAR WITH THE OPERATION, SERVICING, AND SAFETY PRECAUTIONS RELEVANT TO THE ENGINE BEING WORKED ON.

This manual contains only very minimal engine maintenance instructions. You should refer to the engine manufacturer's owner's manual for specific maintenance instructions for the engine on your generator set. Any maintenance instructions or recommendations in the engine owner's manual take precedence over any of the following general recommendations.

1. Clean and/or replace any fuel, oil, and/or air filters per the engine manufacturers' guidelines.
2. Check oil level regularly; at least every 5 to 8 hours of operation. Be sure the proper oil level is maintained.
3. Change the oil as is recommended in the engine manufacturer's owner's manual.
4. Replace the spark plug(s) as is recommended by the engine manufacturer (if applicable to the engine).
5. Clean the cooling fins on the engine to keep the engine's heat dissipation potential at it's maximum.
6. Inspect and clean all governor and carburetor linkages and make sure they operate properly.
7. Inspect the recoil rope for any damage and replace it if necessary (if applicable).
8. Clean the trash screen around the recoil or other cooling air intake.

STORAGE OR LONG TERM NON-USAGE

If you will not be using the generator set for a significant amount of time (3 months or longer) you should store the generator to prevent any problems that could arise from sitting idle. Please fully read the following guidelines prior to storing the unit.

1. Drain the used oil from the engine's crankcase and refill it with fresh, clean oil (if your engine is diesel proceed to step 4).
2. Remove the spark plug and pour 1 oz. of clean engine oil into the cylinder. Put a rag over the spark plug port and turn the engine over approximately 5 times to distribute the oil in the cylinder. Replace the spark plug but **do not** reconnect it. This will help prevent accidental or unauthorized starting.
4. Provide maintenance to the engine and generator set as described in the engine and generator maintenance sections of this manual.
5. Cover any bare metal spots with paint or another type of rust preventative.
6. Disconnect and remove the battery if your generator set is so equipped.

ORDERING PARTS

When Generator repair parts are needed, they may be obtained by calling the Parts Department at Baldor Generators or the nearest local office of Baldor Electric Motors and Drives. Accurate information such as the following will assure that you receive accurate parts for your particular generator:

1. Provide the model of the generator set.
2. Provide the serial number of the generator set.
3. A complete and accurate description of the part along with a part number (if known).
4. Quantity of parts.

NOTE: Engine parts can usually be obtained from a local representative of your engine manufacturer via the information in the engine manufacturer's owner's manual.

Baldor generator can obtain engine parts if necessary. However we do not stock engine parts nor are we a dealer in engine parts.

SERVICE

Service for your generator set can be obtained from the service department at Baldor Generators by calling (920)236-4200. Please have the following information available prior to contacting the factory:

1. The model of the generator set.
2. The serial number of the generator set.
3. A complete and accurate description of the problem.

GENERAL INSTALLATION & SITE SELECTION GUIDELINES



This information is for general reference only! It must not be used as the single source of information for installing the generator set. For more specific/detailed information read the installation manual that accompanied the generator set.



Incorrect installation of the generator set could result in property damage, injury, or death! Installation of this generator set must be performed by qualified / professional technicians or contractors.



The generator set installation along with its fuel supply piping should be inspected on a regular basis for potentially dangerous situations (i.e. fuel leaks, exhaust leaks, loose or broken wiring, etc.). Any potential problems should be corrected by a qualified technician as soon as possible.



Baldor Generators does NOT recommend and strongly discourages the operation of their generators inside residential or other occupied buildings due to the hazards associated with toxic fumes, hot operating conditions and combustible fuel

Prior to installing the generator set, an adequate operating site should be selected for it. When selecting a site for your generator set, take into account factors such as safety, noise, cooling and other miscellaneous considerations.



Only generator sets with the factory installed enclosure should be placed outdoors in constant, direct exposure to the elements. These enclosure- equipped units should be mounted outside in a fashion similar to home central air conditioners.

SAFETY CONSIDERATIONS

1. The generator set must not be located near any combustible material due to the substantial amount of heat generated by the unit while it is operating.
2. When the installation is in a confined area, the exhaust must be plumbed to the outside air. Care must be taken so that no re-circulation of exhaust fumes exists.
3. Adequate ventilation must be present whenever the generator set is running not only to evacuate the heated cooling air and exhaust fumes, but also to prevent the potential of an LP fume concentration.
4. The generator set should not be located in a spot that is prone to standing water

Baldor generator strongly recommends that your AE Unit be installed on a concrete or cement slab of appropriate size relative to the generator's base which is at least five (5) feet from any building, structure, shrubbery, or any other obstruction that could possibly catch fire due to the extreme heat output of this generator set.

COOLING CONSIDERATIONS

1. when installing the generator set, it should be mounted no closer than 5 feet away from any wall or object that would inhibit the cooling air flow that is necessary to operate the unit properly.
2. When installing the generator set inside a non-occupied building, an adequate supply of cooling air must be directed/ducted to the cooling air intake of the engine. The heated cooling air blowing off the back of the engine must be directed away from the unit so as not to be re-circulated with the cool intake air.
3. It is extremely important that the generator set be kept clear of snow, leaves, grass and other debris.

NOISE CONSIDERATIONS

1. This generator set will develop noise levels similar to that of common lawn and garden equipment.
2. Units supplied with enclosures will have their noise level significantly reduced.

MISCELLANEOUS CONSIDERATIONS

1. There should be adequate access to the generator set for maintenance/repair.

ELECTRICAL INSTALLATION GUIDELINES



Incorrect installation of the generator set could result in property damage, injury, or death! Installation of this generator set must be performed by qualified / professional technicians or contractors.



This information is for general reference only! It must not be used as the single source of information for installing the generator set. For more specific/detailed information read the installation manual that accompanied the generator set as well as the transfer switch manual.

There are two main wiring circuits that must be installed by a licensed electrician to properly interface your Baldor generator set with your transfer switch and the building/facility it will be providing power to. The connection on the generator set consists of two terminal blocks, which are located on the generator set.

On units with the factory-installed enclosure, the connection box is located in the engine enclosure bulkhead. Access to the customer connection box is achieved by removing the appropriate louvered enclosure end panel (See Drawing on following page).

On units without the factory-installed enclosure the customer connection box is located either above the generator windings or it is mounted on the generator frame next to the unit.

REMOTE START CONNECTIONS

These terminal block connecting points (See figure 1) are where you connect the two wires from the remote start contacts of the transfer switch. Once a connection is made across these connecting points (via the transfer switch or some other switch device), a circuit is completed to the control logic of the generator set causing the unit to start. The unit will remain running until this connection is opened. Once the remote start connection is opened, the logic circuitry allows the engine to run for approximately 60-90 seconds before it shuts off. This time delay is to allow the engine to run unloaded for a period of time to cool down.

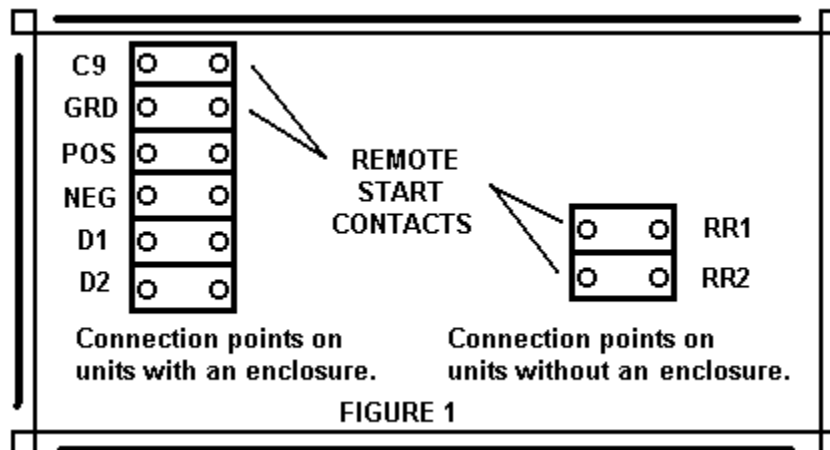

AC POWER CONNECTIONS

These terminal block connections are used to interface the wires/cables from the emergency power supply input terminals located inside the transfer switch.

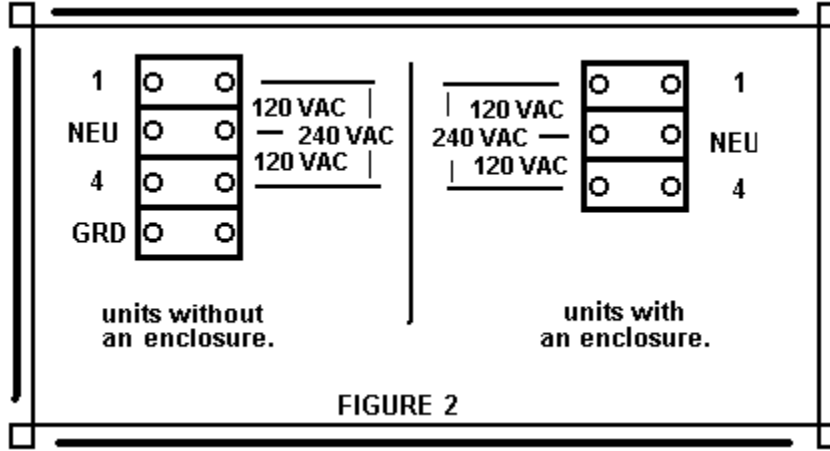

BATTERY CHARGER CONNECTIONS (OPTIONAL)

If you purchased a Master Control Systems Inc. Battery charger with your generator set you must run two sets of wires from the battery charger to the generator set.

UNITS WITH FACTORY INSTALLED ENCLOSURE

The terminal block that contains the connection points for the remote start on the enclosed units also contains the connection points for interfacing the battery charger to the generator set.

The wires from the terminals labeled DK1 and DK2 on the battery charger go to the D1 and D2 terminal connection points on the terminal block pictured in figure 3.

The wires from the terminals labeled B+ and B- on the battery charger go to the POS and NEG terminal connection points on the terminal block pictured in figure 3.

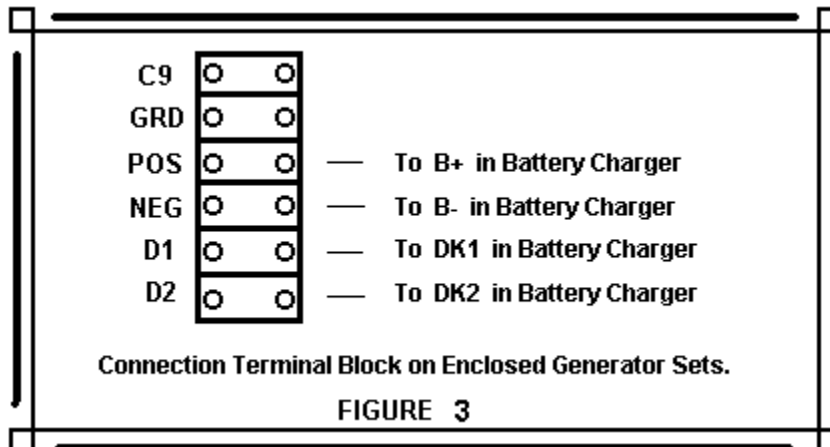

UNITS WITHOUT ENCLOSURE

The wires from the terminals labeled DK1 and DK2 on the battery charger must be connected across the starter motor. One lead must go to ground and the other must go to the starter motor (or the 'switched' B+ on the Starter Solenoid). DK1 and DK2 are not polarity sensitive and are therefore interchangeable with one another.

Wires from the terminals labeled B+ and B- on the Battery Charger go to the battery on the generator set. B+ goes to the positive post of the battery and B- goes to the negative post on the battery.

NOTICE

It is important, not only functionally, but also for safety reasons that the Generator set, transfer switch and battery charger share a common Ground and neutral.

NOTICE

To determine the proper type and gauge of wire to use for connecting the generator set, transfer switch, and battery charger together, you should consult a local licensed electrician.

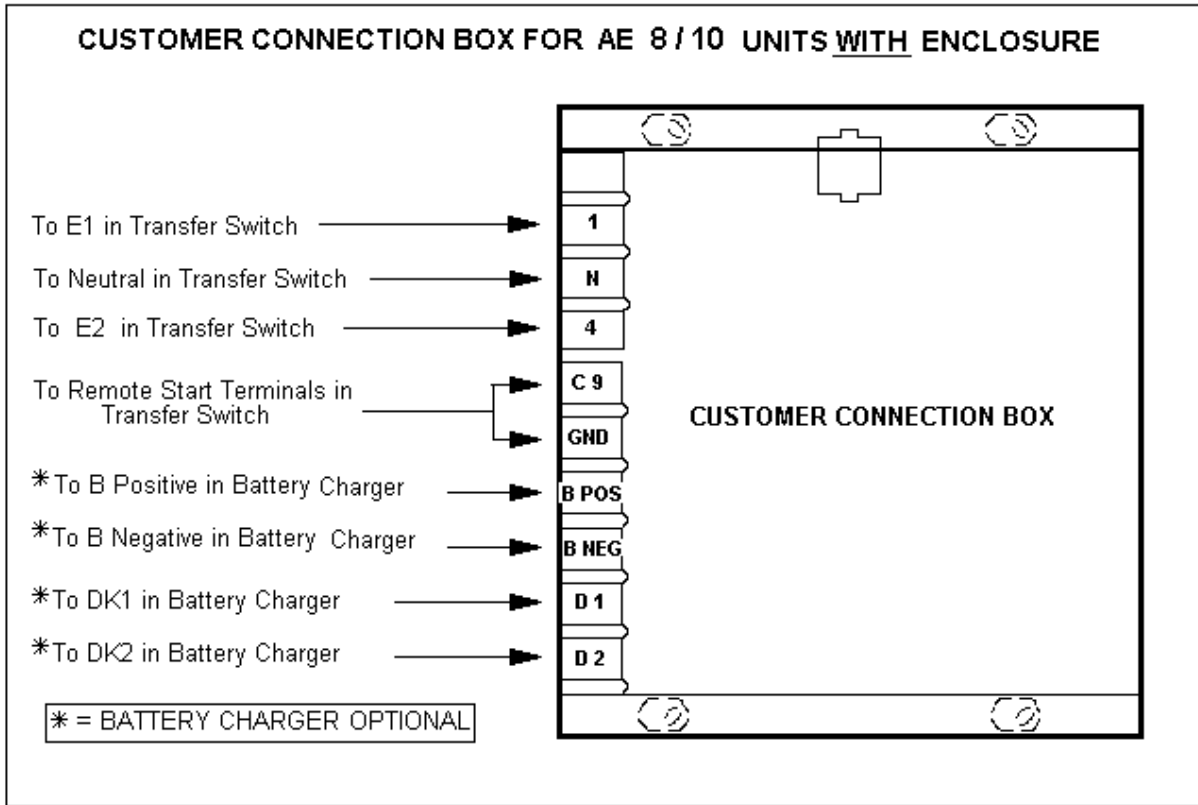

Baldor Generators strongly recommends that all electrical devices share a common ground (i.e. Generator Set, Transfer Switch, Battery Charger, Load Devices, etc.). The grounding stud for the generator set is located under customer connection box.

GASEOUS FUEL INFORMATION



INCORRECT INSTALLATION OF THIS GENERATOR SET COULD RESULT IN PROPERTY DAMAGE, INJURY, OR DEATH! INSTALLATION OF THIS GENERATOR SET MUST BE PERFORMED BY A QUALIFIED, PROFESSIONAL TECHNICIAN OR CONTRACTOR.



This information is for general reference only! It must not be used as the single source of information for installing the generator set. For more specific/detailed information read the installation manual that accompanied the generator set.

Before undertaking installation of gaseous fuel supply piping from a remote fuel source to the generator set, a check should be made concerning local and state regulations governing the use, application, and installation of gaseous fuel. These regulations along with the standards set forth by the NFPA (National Fire Protection Agency) should be followed for safe, dependable, and proper installation.

The applicable NFPA regulations are covered in the following NFPA Publications:

- No. 37 - Combustion Engines
- No. 54 - Gaseous Appliances and piping
- No. 58 - Storage and handling LPG

These publications are available at a nominal price from:
The National Fire Protection Agency P.O. Box 9101 Quincy, MA 02269

GASEOUS FUEL SUPPLY PIPING



GASEOUS FUELS ARE HIGHLY COMBUSTIBLE AND CAN CAUSE EXPLOSIONS, FIRE, INJURY, OR DEATH! THE FUEL SUPPLY SYSTEM MUST ONLY BE INSTALLED AND ADJUSTED BY AN EXPERIENCE, PROFESSIONAL TECHNICIAN USING APPROVED PIPING AND COMPONENTRY.

For the purpose of calculating piping size, the fuel consumption of an engine is figured at approximately 10,000 BTU's needed per horsepower per hour. For example, a 10 horsepower engine will require 100,000 BTU's of gaseous fuel per hour. Operating on natural gas which contains 1,000 BTU's per cubic foot, this engine would require 100 cubic feet of natural gas an hour to operate properly. In addition to fuel consumption, the following factors must be considered when installing the gaseous fuel supply piping:

1. Pressure loss due to the number of fittings (elbows, reducers, etc.).
2. Specific gravity of the gaseous fuel.
3. Pressure loss due to the length of the fuel supply piping.

The accompanying gas flow/pipe capacity charts list the capacity of various sizes and pipe run lengths. The capacity, which is given in cubic feet per hour, is calculated for both propane and natural gas. A pressure drop of 0.3' (water column) is used to account for a nominal number of fittings and metering equipment. Referring to the fuel consumption figures, we can use this chart to calculate proper sizing. For example, if the engine is located 30 feet from the main fuel source's primary regulator and the engine needs 100 cubic feet of natural gas per hour, you can easily determine that the pipe size must be at least 3/4 inch in order to deliver the volume of fuel necessary for the engine to operate properly.

PRIMARY REGULATOR (not supplied)

The function of the primary regulator is to provide initial control of the fuel under pressure as it comes off a transmission line, or in the case of LP gas, from a storage tank. The primary regulator distributes line pressures to more workable pressures ranging from 4 to 6 ounces (approximately 11" of water column).

A natural gas supplier may boost pressure somewhat to achieve even distribution. However these pressures are usually under 50 PSI. For this reason, the primary regulator used with natural gas systems does not have to regulate the high pressures normally associated with LP gas systems.

SECONDARY REGULATOR (supplied)

This regulator provides the final control of the gaseous fuel prior to it entering the carburetor.

This regulator is frequently referred to as the Low Pressure Demand Regulator. This regulator receives gas at a pressure of 4 to 6 ounces from the primary regulator, then reduces the pressure and delivers it to the engine's carburetor as the engine demands.

LP Tanks

The fuel vessel is usually the responsibility of the fuel supplier. The fuel supply must be adequate in order to meet the customer's needs. The fuel tanks / cylinders must meet all requirements set forth by local and state regulations.

LP Cylinder Tanks

This type of tank is commonly used on the smaller portable generator sets and is usually only equipped with a manual shut-off valve. Although this type of tank is of adequate strength to withstand the high fuel pressures, it has one drawback in that the tank is normally of such a small size that you can only achieve minimal run times off of the tank of fuel before it has to be refilled (4 to 7 hours).

LPG bulk tanks

The American Society of Mechanical Engineers has established certain requirements for the construction of LPG bulk tanks. These tanks range in size from 20 gallon capacity all the way up to 90,000 gallons in increments of 20 gallons. Although some of the smaller tank sizes are used in mobile applications, the ASME approved tank is generally used in stationary applications.

Because tank pressures range from 0 to 200 PSI in LPG tanks, these tanks cannot be filled to capacity. ASME tanks are filled to 90% capacity to allow for expansion of gases during increases in temperature.

The recommendation of the local certified professional fuel supplier should be followed when installing storage vessels and fuel piping.

Fuel valves

While the secondary demand regulator supplied with this generator set is designed to close and stop fuel when the engine is not running, it should not be relied upon to completely seal off the fuel system when the engine is stopped. A ruptured diaphragm or a piece of dirt in the regulator could prevent the regulator's valves from seating with a result that gas would continue flowing through the carburetor, into the engine and out into the surrounding air. Since gaseous fuels are heavier than air, they tend to settle in low areas, which could present a serious hazard.

Electric fuel shut-off valves

This type of fuel valve interfaces with the electronic control circuitry of the generator set and is automatically activated to seal off the fuel the instant the engine's ignition system is shut down.

This type of fuel valve is mandated by federal and state regulations in most generator set applications.

Manual Fuel Valves

In addition to the electrical fuel shut-off valve, a LPG system should include a manually operated safety shut-off valve located close to the fuel source. This valve may well be a valve located on the tank itself or it may be a valve installed in the fuel transmission line.

A manual shut-off valve is often required by existing regulations in many localities.

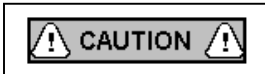

For indoor installations by NFPA definition, an automatic positive shut-off valve must be installed to assure that the flow of fuel will be stopped should the engine fail while it is unattended.

PROPANE GAS FLOW CHART

Pipe Capacity in Cubic Feet

		IRON PIPE SIZE										
		1/2"	3/4"	1"	1 1/4"	1 1/2"	2"	2 1/2"	3"	4"	6"	8"
LENGTH OF PIPE (FEET)	15	48	109	218	475	772	1570	2437	4115	8786	24497	50007
	30	33	76	153	339	538	1127	1741	2975	6140	17325	35353
	45	27	63	126	275	443	934	1456	2469	5001	14781	28865
	60	24	54	110	241	386	817	1266	2184	4304	12236	25004
	75		49	98	218	345	709	1108	1899	3798	10957	22345
	90		44	89	196	310	633	987	1709	3482	10001	20414
	105		41	83	180	285	582	905	1551	3228	9254	18895
	120			76	171	266	544	848	1456	3038	8659	17673
	150			69	153	241	494	772	1323	2754	7748	15825
	180			63	142	222	456	709	1234	2532	7064	14432
	210			58	130	202	418	652	1127	2342	6539	13356
	240				120	190	393	614	1063	2209	6077	12405
270				113	180	367	576	1000	2057	5697	11780	
300				108	171	345	544	943	1899	5381	11179	

An engine needs 10,000 BTU's / HP
 For Propane there are 91,547 BTU's /Gal
 For Propane there are 2,516 BTU's / Cubic Ft.

NATURAL GAS FLOW CHART

Pipe Capacity in Cubic Feet

		IRON PIPE SIZE										
		1/2"	3/4"	1"	1 1/4"	1 1/2"	2"	2 1/2"	3"	4"	6"	8"
LENGTH OF PIPE (FEET)	15	73	165	332	722	1174	2386	3704	6253	13352	37229	
	30	50	115	232	515	818	1712	2646	4521	9331	26330	53728
	45	41	95	191	418	673	1419	2213	3752	7600	22462	43867
	60	37	83	166	366	587	1241	1924	3319	6542	18595	37999
	75		74	149	332	524	1077	1684	2886	5772	16652	33959
	90		67	137	298	433	962	1501	2597	5291	15200	31025
	105		63	126	274	433	885	1376	2357	4906	14064	28715
	120			115	260	404	827	1289	2213	4618	13160	26859
	150			105	233	366	750	1174	2011	4185	11775	24050
	180			96	216	337	693	1077	1876	3848	10736	21934
	210			89	197	308	635	991	1712	3559	9937	20298
	240				183	289	596	933	1616	3357	9235	18990
	270				171	274	558	875	1520	3127	8658	17903
	300				164	260	524	827	1433	2886	8177	16998

An Engine needs 10,000 BTU's / HP
 For Natural Gas there are 1,000 BTU's / Cubic Ft.

OPERATION

PRIOR TO STARTING THE UNIT:

1. Locate and set up the generator set in an open, dry, well ventilated and reasonably level location.



OPERATING THIS UNIT IN AN AREA NOT SUITABLE FOR IT'S PROPER USE MAY CAUSE DAMAGE TO THE UNIT, SEVERE INJURY, OR DEATH. SEE "LOCATION INFORMATION" SECTION LOCATED ELSEWHERE IN THIS MANUAL.

2. If grounding is required for your application, check to make sure your unit is grounded properly.
3. Check the engine's oil level and add whatever amount of oil is necessary to bring it up to the level that is recommended by the engine manufacturer.
4. Check the fuel system for fuel leaks.
5. Make sure all circuit breakers are set (pushed In).

CONTROLS AND THEIR FUNCTIONS

Master Control Switch:

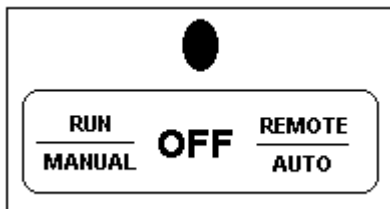

This switch is a three position toggle switch which allows the user to choose the automatic or manual mode of operation.

The center position is the off position.

By putting this switch in the OFF position the generator set will not start under any conditions.

To reset the control logic after a fault has occurred, this switch must be put into the Off position for a minimum of 10 seconds.

Run/Manual Mode: When the Master Control Switch is put into this position it immediately energizes the crank cycle to start the generator set. The generator set will continue to produce power until the Master Control Switch is put into the 'OFF' position or until a fault condition develops.

Remote/Auto Mode: When the Master Control Switch is put into this position the generator set can only be started by making a connection across the remote start connection points on the terminal block located in the control box.

This is the position you need to have the Master Control Switch set in when you wish to operate the Generator Set automatically in conjunction with a Transfer Switch.

Should this remote start connection be opened up while the engine is running the engine will shut down after a 60-90 second 'Cool Down' time delay.

The engine can be shut down immediately from this position by putting the Master Control Switch into the 'OFF' position.

A fault condition will also shut the engine down immediately.

Fault Indicator Light:

This circular Red indicator light will come on in conjunction with the engine shutting down whenever a fault condition develops.

One Fault Condition that will cause a shut down is if the engine's starter motor cranks for more than 30 seconds without the engine starting. This fault shutdown is to prevent damage to the starter motor.

Another Fault Condition will develop if the generator set stops producing power while the engine is running. This fault shutdown is to prevent further potential damage to the generator end itself.

Another Fault Condition will develop if the engine's Low Oil Pressure Protection System shuts the engine down.

To reset the Control Logic once a Fault Condition has occurred, you must put the Master Control Switch onto the 'OFF' position for a minimum of 10 seconds.

Fuse for the Control Logic Board:

This fuse is rated at 1 Amp. It's purpose is to prevent excessive and potentially damaging current from getting to the circuit board.

Circuit Breaker:

The Circuit Breakers on the generator set provide overload protection for the generator set. These Breakers protect the generator set against potential damage from excessive AC current.

SIMPLE TROUBLESHOOTING

Listed below are the more simple solutions to some of the more common problems that are reported to the Service Department at Baldor Generators. These troubleshooting solutions are meant to be an aid for a person who has minimal electrical knowledge and experience. More in-depth, detailed troubleshooting information for a person more knowledgeable and experienced in electricity can be obtained by contacting the Technical Service Department at Baldor Generators by calling (920) 236-4200.



BEFORE BEGINNING TO TROUBLESHOOT THE GENERATOR SET, DISCONNECT THE SPARK PLUG (IF APPLICABLE) AND THE BATTERY (IF APPLICABLE) AND ALLOW THE UNIT TO COOL DOWN.



EYE PROTECTION SHOULD BE WORN WHILE TROUBLESHOOTING THIS GENERATOR SET.



THE CAPACITOR USED IN THIS AE8 GENERATOR SET CAN STORE AND DISCHARGE A HIGH VOLTAGE CHARGE. BEFORE WORKING WITH, OR AROUND THE CAPACITOR YOU SHOULD DISCHARGE IT BY SHORTING THE CAPACITOR'S LEADS TOGETHER WITH A SCREWDRIVER THAT HAS AN INSULATED HANDLE YOU CAN HOLD ON TO.

NO OUTPUT

Possible Problems:

1. **The generator speed is too slow.** If the generator is turning too slow the generator set will produce low or no output voltage. Make sure the generator is turning at the speed on the nameplate.
2. **Broken wires or loose connections.** Broken wires or loose connections can cause the generator set to have low or no output voltage. Check all wiring for broken wires and bad/loose connections.
3. **Bad capacitor.** If the capacitor in your AE8 generator goes bad, your generator set will produce no power. To check the capacitor, usually located on the tail end of the generator) you should first discharge it as previously explained and then remove the wires that connect to it. Then put a 12 VDC charge into it by connecting the leads of a 12 VDC battery across the capacitor's terminals for one second. Then allow the capacitor to sit undisturbed and disconnected from everything for 30 minutes. After 30 minutes measure the DC voltage potential across the capacitor. If the capacitor is good, it will still have approximately 12 VDC charge in it. If the capacitor is bad, the voltage potential across the capacitor will be substantially less.
4. **Bad circuit breaker.** If a circuit breaker opens up and will not reset, or the reset button is not free-floating, your generator will not produce power out of all the receptacles. Check for continuity across each circuit breaker with a continuity tester or ohmmeter (The wires must be removed from the circuit breaker prior to checking it).
5. **Loss of residual magnetism.** Loss of residual magnetism will not allow the generator's excitation system to build up and thus the generator set will not produce any power. To 'Flash' the generator set, (restore residual magnetism) follow these steps:

Preferred Method

- A. With the generator set stopped, remove the generator's end cover and locate the set of three posts on the rotor plate at the tail end of the rotor (there will be a wire wrapped around the center post and the left hand post).
- B. Using a 12 VDC battery, touch the positive battery lead to the center post while touching the negative battery lead to the right hand post. Allow the battery to remain across these posts for 2 seconds.
- C. Replace the end cover and start the unit.

Alternate Method

With the generator running and the end cover removed, momentarily connect a 12 VDC battery across the capacitor's terminals for a fraction of a second. (Having the battery across the capacitor longer than a fraction of a second may damage the windings of the generator). Stop the unit after doing this and replace the end cover. If you still have no output, look for other reasons or contact the Technical Support Department at Pow'R Gard Generator Corporation (920) 236-4200.



BE EXTREMELY CAREFUL WHEN USING THE ALTERNATE METHOD FOR FLASHING THE GENERATOR AS YOU WILL BE WORKING AROUND FAST, ROTATING COMPONENTS ALONG WITH LIVE WIRES AND BARE CONNECTIONS.

LOW VOLTAGE OUTPUT

Possible Problems:

1. **Generator speed too slow.** If the generator is turning too slow, the generator set will produce low or no output voltage. Make sure the generator is turning at the speed specified on the nameplate.
2. **Broken wires or loose connections.** Broken wires or loose connections can cause the generator set to have low or no output voltage. Check all wiring for broken wires and bad/loose connections.

HIGH VOLTAGE OUTPUT

Possible Problems:

1. **Generator speed too fast.** If the generator is turning too fast the generator set will produce high output voltage. Make sure the generator is turning at the speed specified on the nameplate.

TROUBLESHOOTING FOR GASEOUS FUEL SYSTEM



GASEOUS FUELS ARE HIGHLY COMBUSTIBLE AND CAN CAUSE EXPLOSIONS, FIRE, INJURY, OR DEATH! THE FUEL SUPPLY SYSTEM MUST ONLY BE INSTALLED AND ADJUSTED BY AN EXPERIENCED, PROFESSIONAL TECHNICIAN USING APPROVED PIPING AND COMPONENTRY.



PRIOR TO MAKING ANY ADJUSTMENTS THAT WILL TAKE THE GENERATOR SET OUT OF IT'S FACTORY PRESET CONDITION, PLEASE NOTE THE CONDITION / SETTING OF THE ADJUSTING DEVICE. THIS WILL ALLOW YOU TO RETURN TO THE FACTORY PRESET CONDITIONS IF IN THE EVENT OF MAKING AN ADJUSTMENT THE GENERATOR SET'S PERFORMANCE GETS WORSE.

Prior to troubleshooting the gaseous fuel systems in regards to an engine not starting, make sure that the engine has ignition. If the engine does not have a 'spark', the problem is not due to a faulty fuel supply, but rather is due to a problem in the engine control circuitry or the engine itself.

BASIC DESCRIPTION

The gaseous fuel system on your generator operates on 6 ounces of pressure. If the fuel is liquid propane (LP), it must be first vaporized before being delivered to the generator. Once at the generator, an electric valve keeps fuel from flowing unless the engine is running. Inside the generator is a regulator (called the secondary regulator) that delivers fuel based on engine vacuum.

Proper maintenance is key to reliable performance. We recommend only those skilled and licensed for repair of gaseous fuel powered generating systems be enlisted to service this product. This basic guide is to assist those knowledgeable with generators in correction of fuel related operation and starting problems.

INITIAL CHECKS

- ✓ Fuel supply is on and available at the fuel valve.
- ✓ Engine has spark and rotates at normal speed (if not, consult the engine operating guide for assistance in your area).
- ✓ Battery is charged and connected properly
- ✓ Assume nothing. If you have not checked it, consider it not checked.

PROBLEMS AND POSSIBLE SOLUTIONS **In Order of Occurrence**

Inadequate Fuel Supply

- ✓ Undersized piping - check pressure at secondary regulator, 6 oz. Minimum.
- ✓ Condensation in line - check for flow potential, water traps and lines that run in and out of buildings.

Improper Fuel Mixture

- ✓ Check main adjustment - see adjustment section (below).
- ✓ Check auto prime adjustment - see adjustment section (below).

Inoperative Fuel Valve

- ✓ Check function by connecting leads to generator battery. If click is heard, valve is working.

Engine Out of Tune

- ✓ Check condition AND function of spark plugs, generators running on gaseous fuel leave the plugs very clean. It is important not to go by looks alone. If in doubt, change.

NOTE

Some Multi-cylinder engines will appear to run well without load but stumble with load, a bad plug is most often the problem.

- ✓ Check condition of air filter - replace if dirty- if pre-cleaner is saturated with oil, the fuel system will be thrown out of balance and not operate properly.
- ✓ Oil Level - All Baldor engines have Low Oil Shutdown of varying types. To be sure, check the oil level and, if no spark, the oil pressure switch function.

ADJUSTMENTS

Auto Prime

Baldor® models from 5 to 12KW can come equipped with an electric solenoid operator 'Auto Prime' device. The device is electrically connected to the starter system on the generator and supplies an initial feed of fuel for quicker engine starting. Once started, the engine's vacuum keeps the fuel flowing.

On generators not so equipped, the engine vacuum is used exclusively to begin and maintain the flow of fuel.

In almost all hard starting or intermittent starting situations, the auto prime is adjusted to rich. Please note this while making this adjustment. You would need to adjust it to be less rich. Begin by locating the auto prime adjustment wheel. It protrudes from the secondary regulator mounted on the generator and is often covered by a red vinyl cap. The adjustment knob is orange and just below the knob is a gold colored washer. To adjust, hold the washer and rotate the orange knob counterclockwise to lean the adjustment. Try this adjustment hot and cold.

In all multi-cylinder engines, the device may be disabled in lieu of adjustment.

Main Mixture

The main mixture is located on the secondary regulator and is a very large brass screw and lock nut.

Begin by loosening the lock nut and counting the turns until the screw just seats. Record this number so that you may return to it later. REMEMBER, the generator DID run previously either at the factory or at the site.

Proceed by disconnecting the generator set's Auto Prime (if so equipped) by unplugging the terminal on the orange wire.

Check that all fuel supply lines are turned on (where applicable).

Check that the generator's main line output breaker is turned OFF (where applicable).



The next step is to start the generator. Voltage will be available at the output terminals and anywhere the generator is connected. Think ahead and warn others of your intentions.

Operate the generator with the operation switch in the "Manual-Run" mode. The engine should begin cranking.

While the engine is cranking, turn the main adjustment screw counterclockwise until the engine starts. Continue to rotate back and forth until smooth operation is obtained. [Adjustments that are too rich (too far counterclockwise) or too lean (too far clockwise) will result in the same rough sound. Use slow, rotating motion to find the smoothest spot.]



Once set, energize the AC breaker and apply available load. Readjust main mixture screw until generator (with or without applied load) is smooth. This will most likely be a slight rotation richer than initial setting at no load.

Shut off engine by placing the Operation Switch into the "OFF" position.

If operation problems persist, contact your dealer or the Baldor Technical Support Staff at (920) 236-4200.

GENERATOR RUNS CONTINUOUSLY OR FAILS TO STOP AFTER RETRANSFER

Basic Theory –

Public Service power energizes ATS

ATS holds "R" terminals open

Generator test switch or exerciser can start generator, as programmed.

Public Service power drops, ATS closes "R" terminals, generator starts.

Ground fault problems in the conduit lead to the majority of continued run problems.

1. Disconnect both the "R" wires at the generator. Put generator control switch into "AUTO".
 - A. Generator should start.
 - B. Generator should only run for 90 seconds. If so, GO TO STEP #3.
 - C. If the generator continues to run, allow 15 minutes.
If the generator shuts down, but not at 90 seconds, record time and contact factory.
2. Jump momentarily the "R" terminals.
 - A. Generator should start.
 - B. Generator should only run for 90 seconds. If so, GO TO STEP #3.
 - C. If the generator continues to run, allow 15 minutes.
If the generator shuts down, but not at 90 seconds, record time and contact factory.
3. Place generator control switch to "OFF"
 - A. Reconnect the "R" terminals at generator. Now, remove the ATS connections.
 - B. Place generator into "AUTO" setting.
 - C. With the "R" wires apart, the generator should not start.
If generator starts, but did not in step 1A, bad wiring exists in conduit.
 - D. Momentarily hold the "R" wires together. Generator should start.
 - E. Open connection from step "D".
Generator should only run for 90 seconds. If so, GO TO STEP #4.
If the generator continues to run, allow 15 minutes.
If the generator shuts down, but not at 90 seconds, record time and contact factory.
4. Check ATS "R" terminals.
 - A. If red light (or other indicator) is on at ATS, public service power is on. Terminals should be open.
 - B. Check manual controls of ATS (generator test, exerciser).
 - C. Replace control logic of ATS.

AE SERIES

INTERCONNECTION

THE FOLLOWING ARE PRINCIPLES OF INSTALLATION.
PLEASE NOTE: LOCAL, FEDERAL, OR NEC CODES PREVAIL OVER THESE SUGGESTIONS.

Abbreviations:

GEN	=	Generator Assembly
ATS	=	Automatic Transfer Switch
Load Center	=	Customer's Normal Panel
Emergency Load Center	=	Those circuits in a separate load box that will be powered by the generator.
Public Service	=	Normal Power Supplier

GEN to ATS Wiring:

- ◇ 3 wires for AC load (4 if three phase) sized for the generator's load amperage.
- ◇ A Ground wire is to connect all circuits (GEN, ATS, Load Centers) to the building's ground system.
- ◇ 2 wires, 14 gauge twisted pair for GEN remote start signal.

GEN to ATS Optional:

- ◇ 120 -volt feed for GEN mounted battery charger.
- ◇ 12 -volt wires (4) for building mounted battery charger.

Load center to ATS:

- ◇ 3 wires for AC feed (four for three phase), sized for ATS rating.
- ◇ A ground wire is connected to all circuits (GEN, ATS, Load Centers) to the building's ground system.

ATS to emergency Load Center:

- ◇ 3 wires for AC feed (four for three phase), sized for ATS rating.
- ◇ A ground wire is to connect all circuits (GEN, ATS, Load Centers) to the building's ground system.

Normal Operation:

- ◇ Public Service power feeds the ATS which connects to the Emergency Load Center.
- ◇ When Public Service power fails, the ATS closes a contact causing GEN to start. Once AC power from generator is observed at the ATS, the ATS will switch the Emergency Load Center over to the GEN.
- ◇ When Public Service power returns, the ATS will switch the Emergency Load Center back to Public Service power and open engine start to contact (telling GEN to shut off).

CAUTIONS:

- ◇ Emergency load center loads must not exceed GEN's capacity.
- ◇ The ATS shall be protected by a circuit breaker appropriate for the ATS rating in the Customer Primary Load Center.

If you have any questions, contact the Product Support Group at (920)236-4200

APPENDIXES

CUSTOMER CONNECTION WIRING DIAGRAM

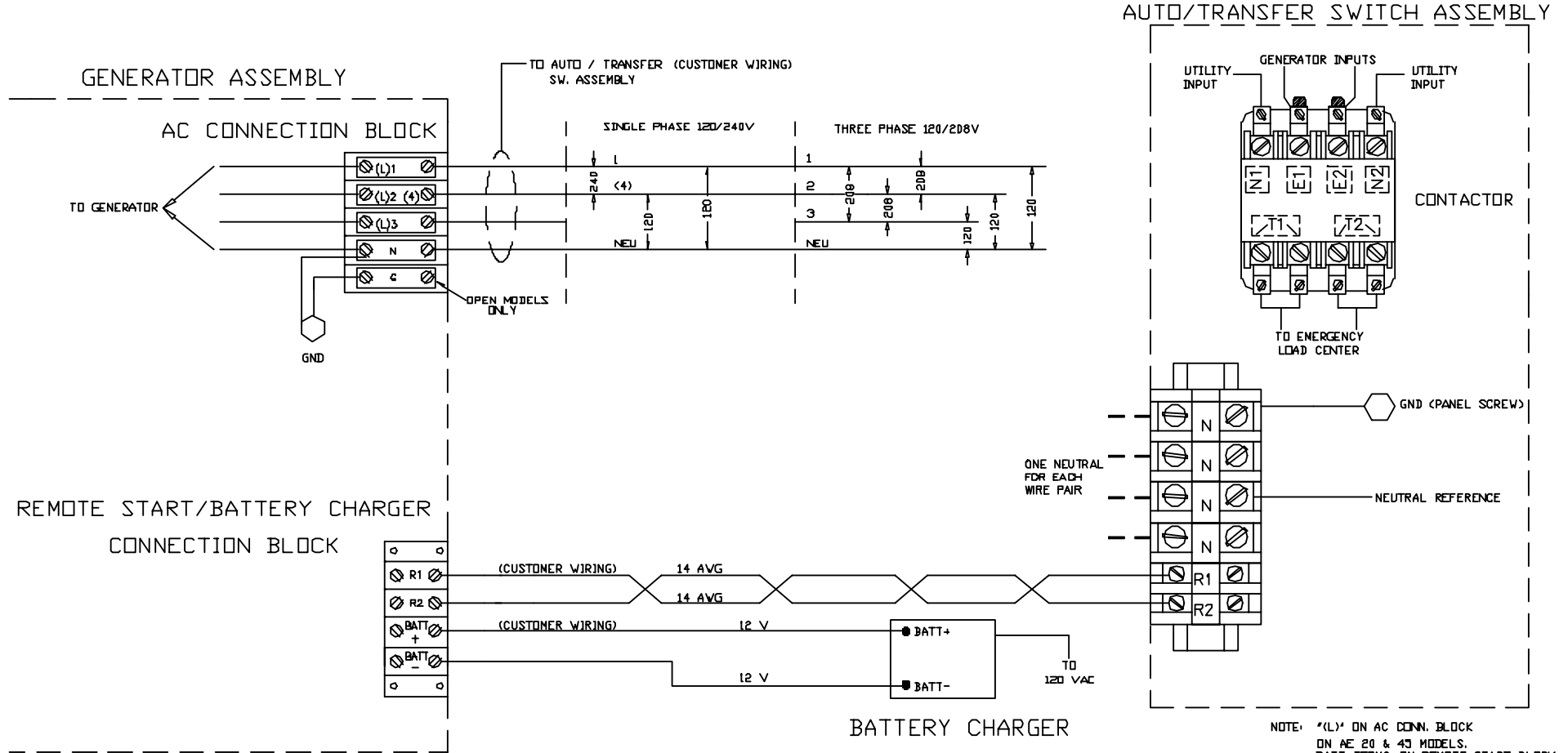

G	-	-	-	-	-	UNLESS OTHERWISE SPECIFIED TOLERANCES: ALL DIMENSIONS IN INCHES. DECIMALS .XXX ±.005 FRACTIONS ±1/64 .XX ±.01 ANGLES ±1° PAINT SPECIFICATIONS, TO FOLLOW DRAWING: 930.18600	CH. BY/DATE:	T & J MANUFACTURING, INC. OSHKOSH, WI. 54901				ELECTRIC P/W R PRD. CT'S
F	-	-	-	-	APP. FOR ONE PIECE QTY./DATE:		SURFACE CLASS:	DESCRIPTION CUSTOMER CONNECTION WIRING DIAGRAM AE SERIES			DWG. NO. 915.24B	
E	-	-	-	-	APP. BY/DATE:		COLOR:	MATERIAL: _				
D	-	-	-	-	RELEASE DATE		SCALE	DATE 12/28/98	DR. BY: BJB	SHEET 1 OF 1	PART NO.	SIZE B
C	-	-	-	-	THIS DOCUMENT IS STRICTLY CONFIDENTIAL AND MAY NOT BE REPRODUCED OR UTILIZED IN ANY WAY WITHOUT PRIOR WRITTEN PERMISSION OF T&J MANUFACTURING, INC.							
B	1/14/99	REMOVED HIDDEN LABELS FROM CONTACTOR.	12	114995	BJB							
A	1/5/99	CHNGD AC CONN LABELS, ADDED NOTE.	ALL	1599	BJB							
LTR	DATE	DESCRIPTION	LOC	ECN#	BY							
REVISIONS												

NOTE: CRANKING SELECT - TO CONVERT TO CYCLE CRANKING CUT J1 & J2
 TIME DELAY - TO ADD 10 SEC. TO START UP CUT J3
 J1, J2, & J3 LABELED ONLY ON THIS DIAGRAM

← MATE 'N' LOCK CONNECTOR
 ▽ FEMALE/MALE BULLET

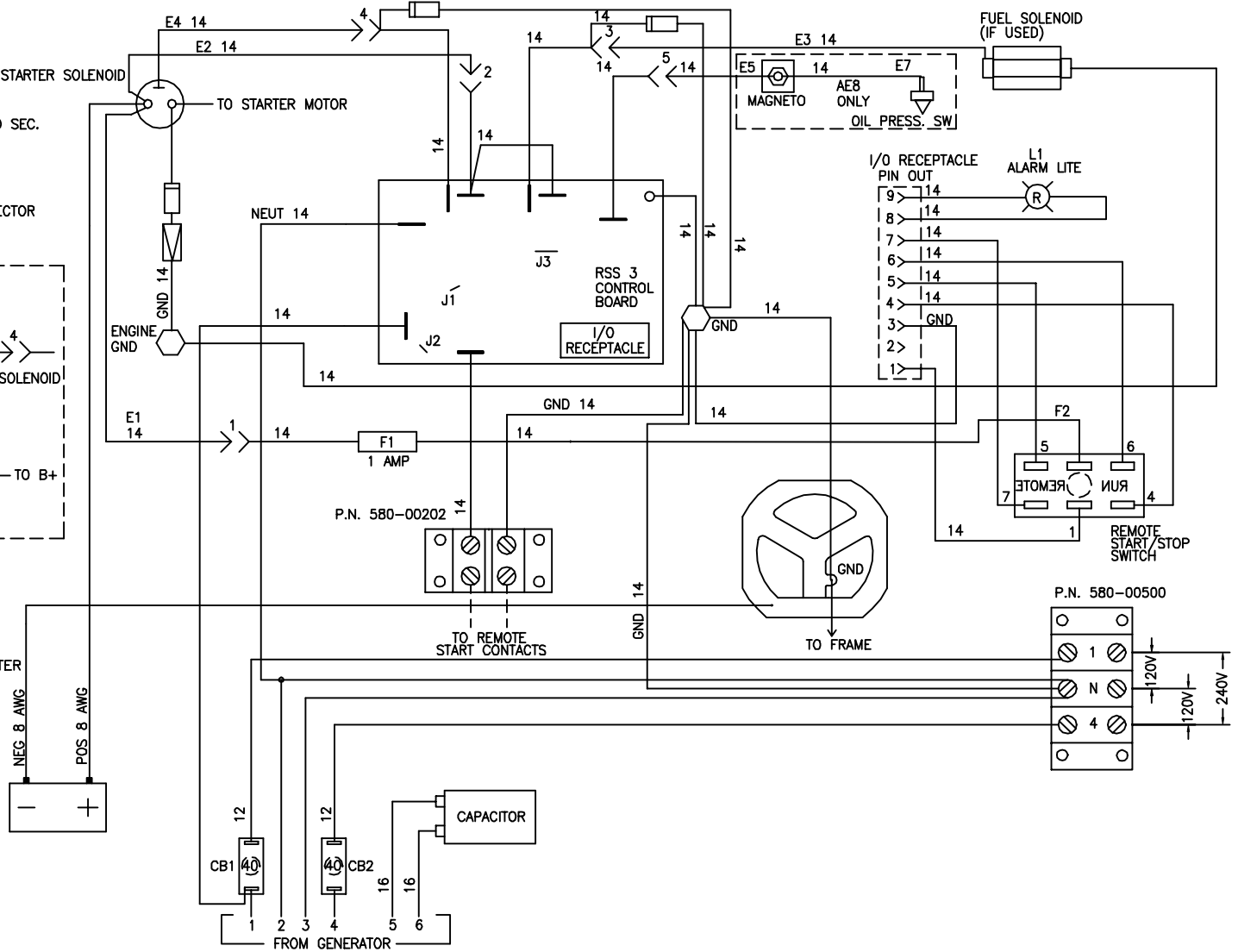
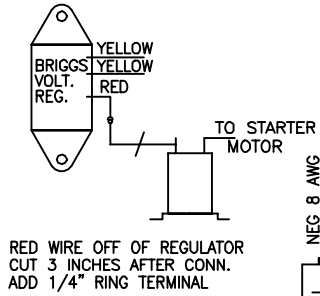
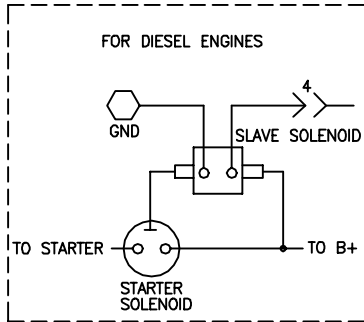

REV. DESC:	BALDOR FORMAT, WAS POWRGARD 910.731 REV E.
REV. LTR:	F BY: MRM REVISED: 14:24:57 02/22/2002 TDR: 251318
FILE:	PGA00002169
MTL:	-
REF:	BW0183D

BALDOR ELECTRIC Co.

CONNECTION DIAGRAM, AE8 OPEN

AE8 OPEN

BW0120D

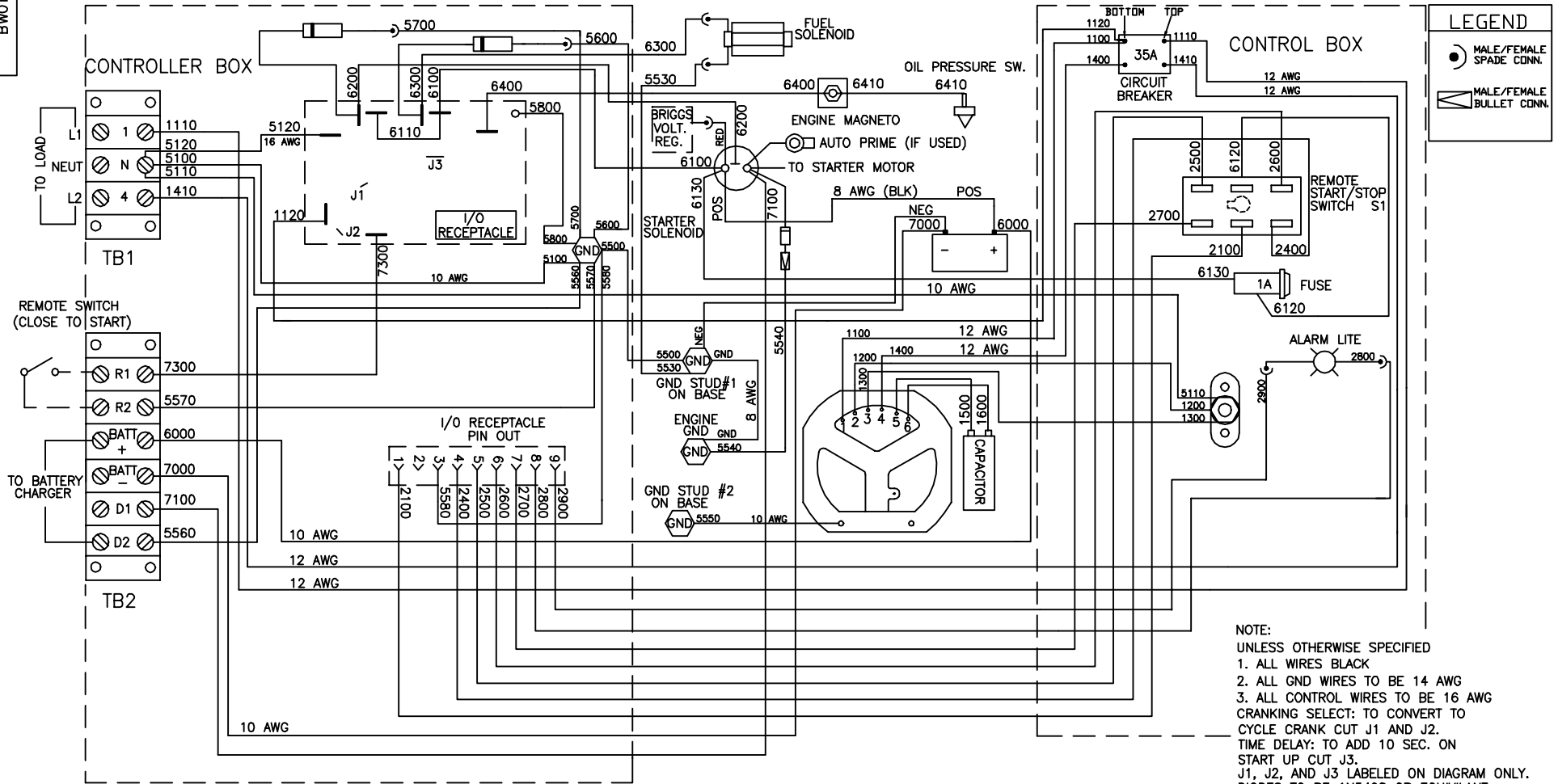

LEGEND

- MALE/FEMALE SPADE CONN.
- ◁ MALE/FEMALE BULLET CONN.

NOTE:
 UNLESS OTHERWISE SPECIFIED
 1. ALL WIRES BLACK
 2. ALL GND WIRES TO BE 14 AWG
 3. ALL CONTROL WIRES TO BE 16 AWG
 CRANKING SELECT: TO CONVERT TO
 CYCLE CRANK CUT J1 AND J2.
 TIME DELAY: TO ADD 10 SEC. ON
 START UP CUT J3.
 J1, J2, AND J3 LABELED ON DIAGRAM ONLY.
 DIODES TO BE 1N5408 OR EQUIVILANT.

REV. DESC: BALDOR FORMAT, WAS POWRGARD 910.00821 REV G			
REV. LTR: H	BY: MRM	REVISED: 07:26:10 02/05/2002	TDR: 251318
FILE: PGA00002008		REF: BW0120D	
MTL: -			

BALDOR ELECTRIC Co.

AEB ENCLOSED 120/240 1PH, CONNECTION DIAGRAM

AE8 ENCLOSED

BW0120D

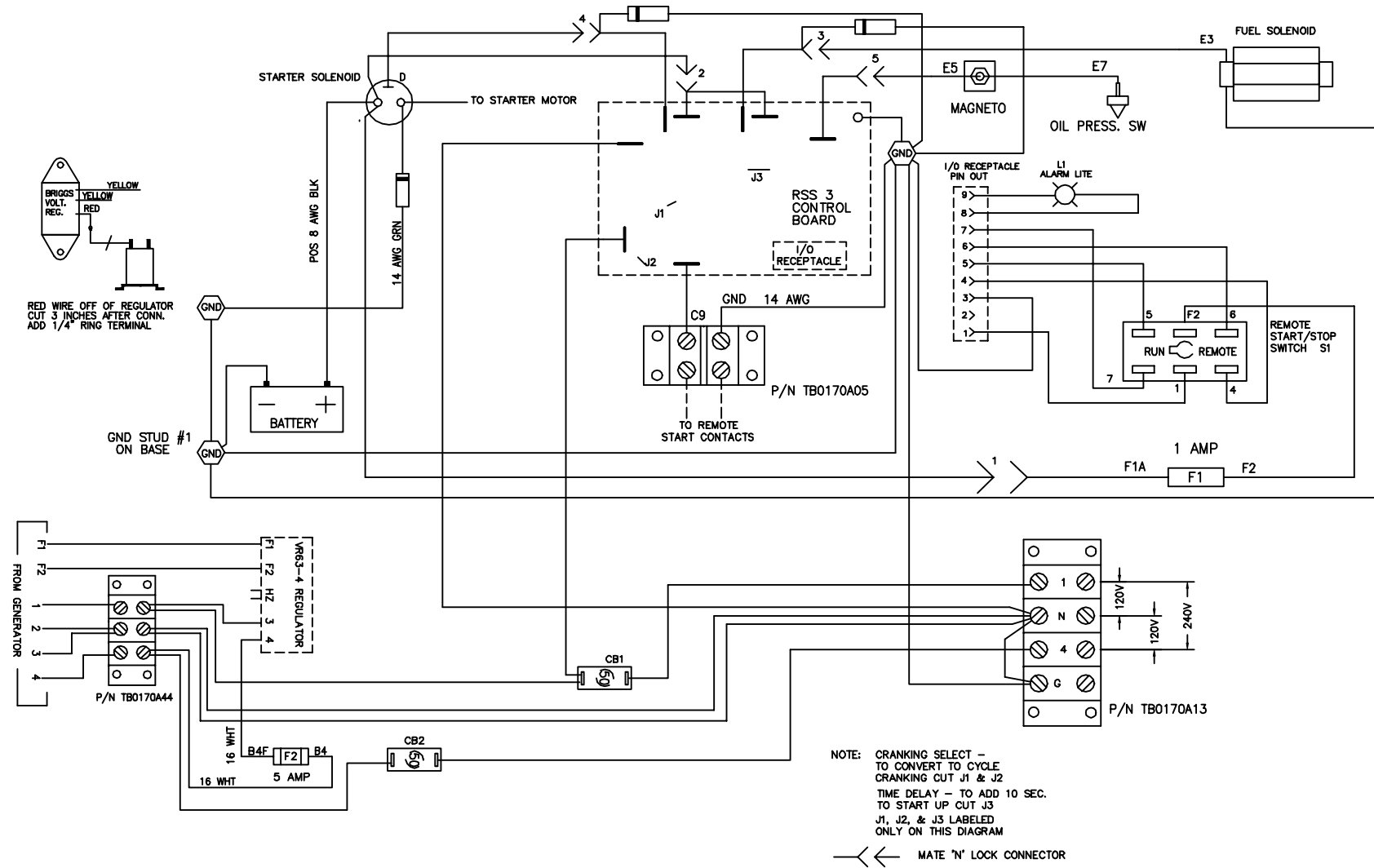

REV. DESC: BALDOR FORMAT, WAS POWRGARD 910.827 REV E.			
REV. LTR: F	BY: MRM	REVISED: 11:16:35 02/27/2002	TDR: 251318
FILE: PGA00002219		REF: BW0201D	
MTL: -			

BALDOR ELECTRIC Co.

CONNECTION DIAGRAM, AE10 OPEN

AE10 OPEN

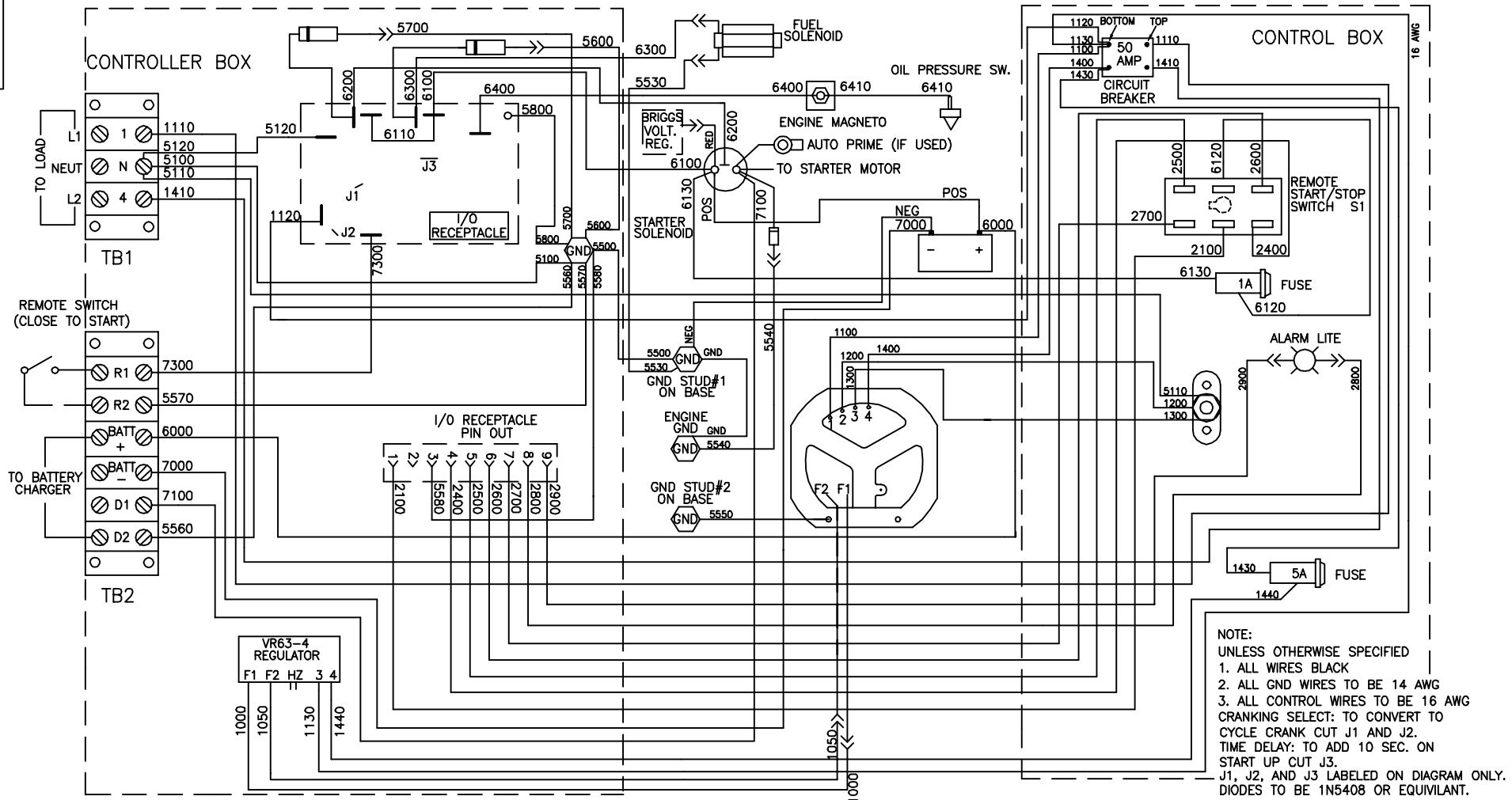

REV. DESC:	BALDOR FORMAT, WAS PG #910.00B23 REV H SHT 1 OF 3
REV. LTR:	-
BY:	HJD
REVISED:	10:37:28 02/07/2003
TDR:	286031
FILE:	PGA00003541
REF:	BW0333D
MTL:	-

BALDOR ELECTRIC Co.

CONNECTION DIAGRAM, AE 10 ENCLOSED 120/240 V(1) PHASE

AE10 ENCLOSED

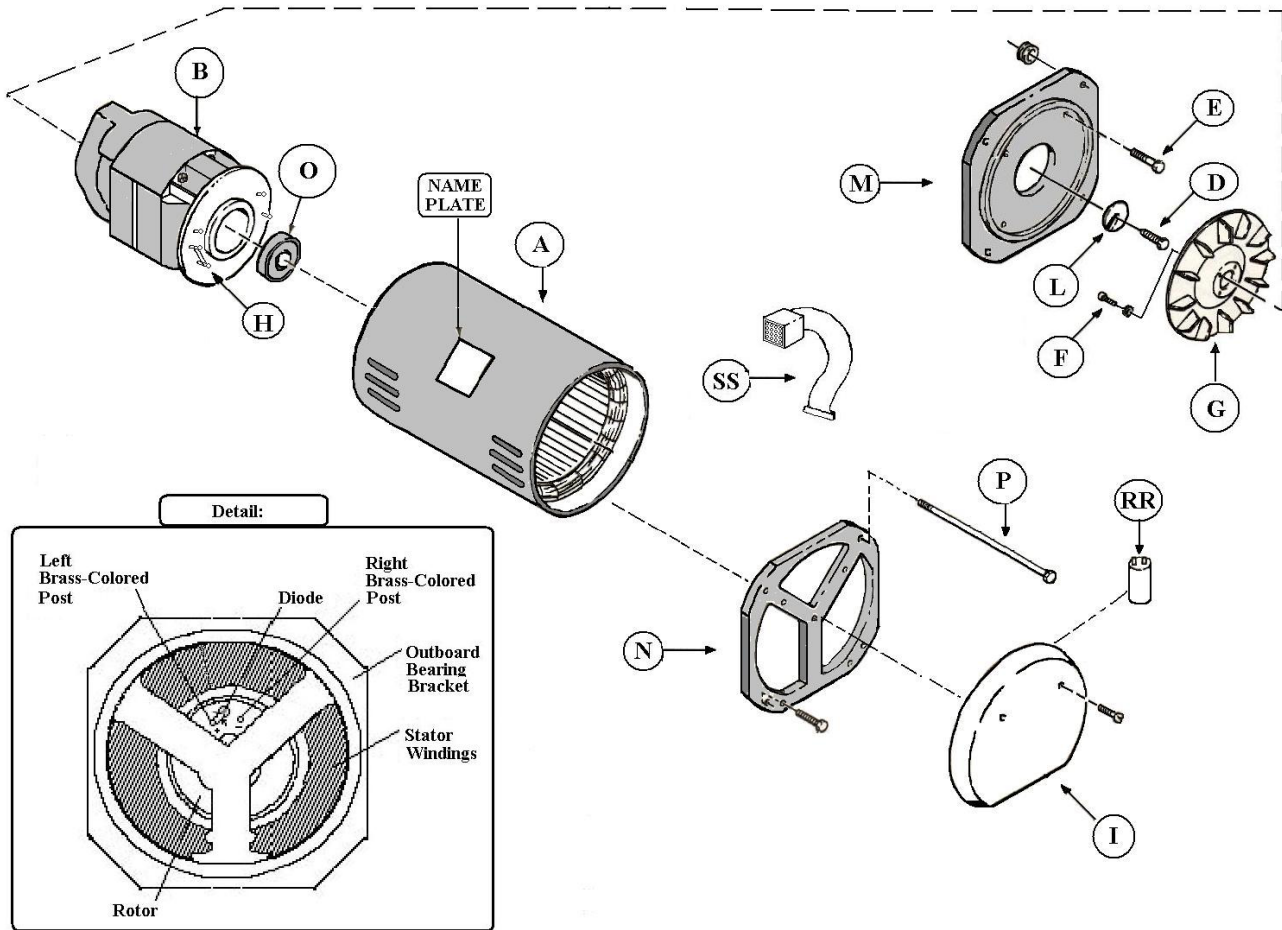

GENERATOR END COMPONENTRY / PARTS LIST AE8 OPEN AND ENCLOSED

	OLD PART#	NEW PART#	DESCRIPTION	OPEN	ENCL
A	46.00075D	61SA0015A03	STATOR ASSEMBLY AE8 OPEN 1 PH	O	
A	46.00075E	61SA0015A04	STATOR ASSY AE8 ENCL 1 PH		E
B	66.00075	61RA0016A00	ROTOR ASSEMBLY	O	E
D	230.04040	Consult Factory	ROTOR ATTACHING BOLT	O	E
E	230.06040	10XN3816K20 *	ENGINE ADAPTOR MOUNTING BOLT	O	E
F	230.12010	84XN1032L10SP	COOLING FAN ATTACHING BOLT	O	E
G	340.00000	61FN3000SP	COOLING FAN	O	E
H	500.16000	DI0176A01SP	ROTOR DIODE	O	E
I	370.03601	EH0321A00*	BLANK END COVER	O	
L	390.00000	HA1037A00SP	'C' WASHER	O	E
M	400.20100A	61EP3204A01*	ENGINE ADAPTOR CASTING	O	E
N	400.20100A	61EP3204A01*	BEARING BRACKET, BRUSHLESS, 8"	O	
N	400.20100K	61EP3204A07*	BEARING BRACKET CASTING		E
O	410.00600	BG6204H03	ROTOR BEARING	O	E
NOT SHOWN	120.00500	EA0000A00SP	KN GASEOUS FUEL REGULATOR	O	E
NOT SHOWN	380.51200	BA0191A00L*	BASE	O	
NOT SHOWN	380.56302	BA0200A00*	BASE, AE8 ENCL, NEW		E
NOT SHOWN	440.62700	HB6022A04SP	HEAT SHIELD	O	
NOT SHOWN	450.05100	HB7025A00 *	MNTING TABS, ATTACHED TO BASE	O	
NOT SHOWN	450.05900	HB6150A01	SUPPORTING CROSS MEMBER, GEN END	O	
NOT SHOWN	450.06200	HB7002A08L*	SUPPORTING CROSS MEMBER, ENGINE	O	E
P	480.00090	HA3187A08SP	STATOR BOLT	O	E
NOT SHOWN	590.40005	WD1036A03 *	GROUND LUG	O	

RR	600.00030C	OC6030F11*	CAPACITOR, 30 MFD	O	
NOT SHOWN	700.00511	RM1088A06SP	VIBRATION ISOLATOR, GEN END	O	E
NOT SHOWN	700.00512	RM1088A07SP	VIBRATION ISOLATOR, ENGINE END	O	E
NOT SHOWN	361.00010	EH0296A00D	CONTROL BOX, EMPTY	O	
NOT SHOWN	520.01100	SP9094	TOGGLE SWITCH, MASTER CONTROL	O	E
NOT SHOWN	550.00435	DI0181A00SP	GLO LITE	O	E
NOT SHOWN	580.00202	TB0171A03*	2 PLACE TERMINAL BLOCK	O	
NOT SHOWN	580.00500	TB0170A11*	3 PLACE TERMINAL BLOCK	O	
NOT SHOWN	580.00300	TB0170A08*	6 PLACE TERMINAL BLOCK		E
NOT SHOWN	610.00040	CK0070A04SP	CIRCUIT BREAKER, 40 AMP	O	
NOT SHOWN	670.00007	FU0066A02*	FUSE, AGC1	O	E
NOT SHOWN	671.00200	FU0064A00SP	FUSE HOLDER	O	E
NOT SHOWN	700.00400	RM1088A01SP	CONTROL BOX ISOLATOR	O	
NOT SHOWN	950.01700	EB1243A00SP	CIRCUIT BOARD, ARSS-3		E
NOT SHOWN	440.98300	EH0278B53L*	AIR INTAKE DUCT, ENGINE END		E
NOT SHOWN	440.98700	EH0278B54L*	AIR INTAKE DUCT, GEN END		E
NOT SHOWN	440.99800	HB6064A07*	MUFFLER SUPPORT BRACKET		E
NOT SHOWN	710.40388	EA0008A08*	MUFFLER		E
NOT SHOWN	710.40955	EA0039A00*	MUFFLER HEAT BLANKET		E
NOT SHOWN	360.09300	EH0309A00*	CIRCUIT BREAKER CONTROL BOX EMPTY		E
NOT SHOWN	370.17100	EH0343A00	CONTROL PANEL FOR CIRC BREAKER CNTRL BOX		E
NOT SHOWN	610.10035	CK0070A27*	CIRCUIT BREAKER, 35 AMP		E
NOT SHOWN	360.09400	EH0308A00*	CUSTOMER CONNECTION CONTROL BOX		E
NOT SHOWN	370.15700	EH0339A00*	CUSTOMER CONN. CNTRL BOX COVER		E

AE10 OPEN AND ENCLOSED

PARTS LIST

	OLD PART#	NEW PART#	DESCRIPTION	OPEN	ENCL
A	47.00101A	62SA0006A00*	STATOR ASSEMBLY	O	E
B	67.00100	62RA0014A00*	ROTOR ASSEMBLY (For 1 Phase gens)	O	E
	67.00122	62RA0016A00*	ROTOR ASSEMBLY (For 3 Phase gens)	O	E
C	400.23500B	61EP3202A02*	BEARING BRACKET	O	E
D	930.21100	Consult Factory	EXCITER FIELD	O	E
E	340.01100	62FN4002*	COOLING FAN	O	E
G	410.00200	BG6207H03	ROTOR BEARING	O	E
H	440.14900	HB7023A00*	RECTIFIER HEAT SINK (END PLATE)	O	E
I	500.20000	DI0177A00SP	RECTIFIERS, 4 terminal	O	E
J	360.06100	EH0302A00*	END BOX (Listed on ly in 1 ph encl)		E
L	370.07900	EH0324A00*	LOUVERED END COVER (Lstd in 1 ph encl)		E
NOT SHOWN	120.00500	EA0000A00SP	KN GASEOUS FUEL REGULATOR	O	E
NOT SHOWN	230.80020	HA3188A00*	ROTOR ATTACHING BOLT	O	E
NOT SHOWN	261.00010	HB6155A00*	'O' RING FOR ROTOR BEARING	O	
NOT SHOWN	400.21300B	HB6177A01*	ENGINE ADAPTOR CASTING	O	E
NOT SHOWN	441.05300	HB6001A00*	MUFFLER BRACKET		E
NOT SHOWN	441.35000	HB6021A00*	EXHAUST OUTLET GUARD (1 PH ONLY)		E
NOT SHOWN	450.05100	HB7025A00	MNTING FEET, ATTACHED TO BASE	O	E
NOT SHOWN	450.06200	HB7002A08L *	ENGINE SUPPORT CROSS MEMBER	O	E
NOT SHOWN	480.10000	10XN3118K176*	STATOR BOLT	O	E
NOT SHOWN	700.00512	RM1088A07SP	VIBRATION ISLOATORS BOTH ENDS	O	E
NOT SHOWN	710.40520	EA0008A09*	MUFFLER	O	
NOT SHOWN	710.40388	EA0008A09*	MUFFLER		E
NOT SHOWN	710.40955	EA0039A00*	MUFFLER BLANKET		E
NOT SHOWN	360.09300	EH0309A00*	CIRCUIT BREAKER BOX (EMPTY)		E
NOT SHOWN	370.17100	EH0343A00	CIRCUIT BREAKER BOX COVER (1 ph)		E
NOT SHOWN	361.00010	EH0296A00D*	SIDE CONTROL BOX WITH COVER	O	
NOT SHOWN	520.01100	SP9094	MASTER CONTROL TOGGLE SWITCH	O	E
NOT SHOWN	550.00435	DI0181A00SP	RED INDICATOR GLO-LITE	O	E
NOT SHOWN	580.00202	TB0170A03*	2 PLACE TERMINAL BLOCK (1 PH)	O	
NOT SHOWN	580.00510	TB0170A13*	3 PLACE TERMINAL BLOCK (1 PH)	O	
NOT SHOWN	610.00050	CK0070A05SP	CIRCUIT BREAKER, 50 AMP (1 ph only)	O	
NOT SHOWN	610.10045	CK0070A29*	CIRCUIT BREAKER, 50 AMP (1 ph only)		E
NOT SHOWN	670.00007	FU0066A02*	FUSE, AGC 1	O	E
NOT SHOWN	671.00200	FU0064A00SP	FUSE HOLDER	O	E
NOT SHOWN	950.01700	EB1243A00SP	CONTROL CIRCUIT BOARD	O	E
NOT SHOWN	120.00110	EM0027A01SP	VOLT REGULATOR, BASLER VR63-4	O	E
NOT SHOWN	670.00005	FU0066A00	FUSE, MTH-5	O	E
NOT SHOWN	671.00200	FU0064A00SP	FUSE HOLDER	O	E

Limited Warranty

Unless otherwise provided, Baldor generators are warranted against defects in Baldor workmanship and materials for a period of time as set forth in the Warranty Period chart below. If a Baldor product is defective due to Baldor workmanship or materials and the defect occurs during the warranty period, then Baldor will either repair the product or replace it with a new one, whichever Baldor believes to be appropriate under the circumstances. Service for warranty issues regarding any Baldor Generators Products Warranty is available by contacting Baldor Generators' Customer Service Department in Oshkosh, Wisconsin. A list of Baldor's generator repair facilities may be obtained by contacting Baldor Generators at: Customer Service, Baldor Generators, 3815 Oregon Street, Oshkosh, Wisconsin 54902, 920-236-4200 (telephone), 920-236-4219 (facsimile). All Baldor products requiring warranty service shall be transported or shipped freight pre-paid, at the risk of the party requiring warranty service, to a Baldor Generator repair facility, or to Baldor Generators' Customer Service Department in Oshkosh, Wisconsin. Written notification of the alleged defect in addition to a description of the manner in which the Baldor generator is used, and the name, address and telephone number of the party requiring warranty service must be included. Baldor is not responsible for removal and shipment of the Baldor product to the service center or for the reinstallation of the Baldor product upon its return to the party requiring warranty service. Customers who are unable to take or ship the Baldor product to a Baldor Generator repair facility, or who desire a repair to be made by other than a Baldor Generator repair facility, should contact Baldor Generators' Customer Service Department at 920-236-4200. Baldor, in advance of such service, must approve a repair by anyone other than a Baldor Generator repair facility in writing. Problems with Baldor products can be due to improper maintenance, faulty installation, non-Baldor additions or modifications, or other problems not due to defects in Baldor workmanship or materials. If a Baldor Generator repair facility determines that the problem with a Baldor product is not due to defects in Baldor workmanship or materials, then the party requesting warranty service will be responsible for the cost of any necessary repairs. Parties requiring warranty service not satisfied with a determination that a problem is outside of warranty coverage should contact Baldor Generators' Customer Service Department at 920-236-4200 for further consideration. EXCEPT FOR THE EXPRESSED WARRANTY SET FORTH ABOVE, BALDOR GENERATORS DISCLAIMS ALL OTHER EXPRESSED AND IMPLIED WARRANTIES INCLUDING THE IMPLIED WARRANTIES OF FITNESS FOR A PARTICULAR PURPOSE AND MERCHANTABILITY. NO OTHER WARRANTY, EXPRESSED OR IMPLIED, WHETHER OR NOT SIMILAR IN NATURE TO ANY OTHER WARRANTY PROVIDED HEREIN, SHALL EXIST WITH RESPECT TO THE GOODS SOLD UNDER THE PROVISIONS OF THESE TERMS AND CONDITIONS. ALL OTHER SUCH WARRANTIES ARE HEREBY EXPRESSLY WAIVED BY THE BUYER. UNDER NO CIRCUMSTANCES SHALL BALDOR GENERATORS BE LIABLE OR RESPONSIBLE IN ANY MANNER WHATSOEVER FOR ANY INCIDENTAL, CONSEQUENTIAL OR PUNITIVE DAMAGES, OR ANTICIPATED PROFITS RESULTING FROM THE DEFECT, REMOVAL, REINSTALLATION, SHIPMENT OR OTHERWISE. This is the sole warranty of Baldor Generators and no other affirmations or promises made by Baldor Generators shall be deemed to create an expressed or implied warranty. Baldor Generators has not authorized anyone to make any representations or warranties other than the warranty contained herein.

Warranty Period

Generator Series	Labor*	Parts
Portable Products (Premier, Powerchief, DG Series, K Series)	1 Year	3 Years
Towable Products (TS)	1 Year or 3,000 Hours Whichever comes first	3 Years or 3,000 Hours Whichever comes first
3600 RPM Standby Systems (Some AE Models)	1 Year or 1,000 Hours Whichever comes first	3 Years or 1,000 Hours Whichever comes first
1800 RPM Standby Systems (Some AE Models, DLC, GLC)	1 Year or 3,000 Hours Whichever comes first	3 Years or 3,000 Hours Whichever comes first
Industrial Standby Systems	1 Year or 1,000 Hours Whichever comes first	2 Years or 1,000 Hours Whichever comes first
Industrial Prime Power Systems	1 Year or 1,000 Hours Whichever comes first	1 Year or 1,000 Hours Whichever comes first
International	1 Year or 1,000 Hours Whichever comes first	1 Year or 1,000 Hours Whichever comes first

Limited Warranty Continued

Notes for Warranty Period:

1. Labor coverage for warrantable repairs is provided for the applicable period not to exceed published rates as contained in the Baldor Generators Warranty Policy. Mileage is allowed only for permanent installations not to exceed published rates as contained in the Baldor Generators Warranty Policy.
2. Proof of purchase date is required for all Portable and Towable products to qualify for any warranty consideration. Serial number and model number will be required for all warranty work.
3. For all other products, a Start-up Inspection Form / Warranty Registration must be completed in its entirety and submitted to Baldor Generators within 30 days of start-up to qualify for any warranty consideration.

Owner's Responsibilities:

The owner is obligated to operate and maintain the generator in accordance with the recommendations published by Baldor Generators in the Operator's Manual for the generator. The owner is responsible for the costs associated with maintenance and any adjustments that may be required.

The owner is responsible for payment of any of the following expenses that might be incurred as a result of a failure under the terms of this warranty:

1. Rental equipment used to replace the equipment being repaired.
2. Telephone or other communication expenses.
3. Living and travel expenses of persons performing service, except as specifically included within the terms of specific warranty.
4. The premium costs for overtime labor requested by the owner.
5. All parts transportation costs.

All warranty claims must be submitted to a Baldor Generator repair facility prior to the expiration of the warranty period. Baldor Generators shall have no responsibility or liability for any defect, latent or otherwise, discovered after the expiration of the warranty period provided herein. Extended warranties are available for certain Baldor products. These warranties are described in Baldor's catalog and other sales literature. Extended warranties are subject to the terms and conditions of this Limited Warranty as modified by the additional terms of the extended warranty.

Limitations:

Baldor Generators is not responsible for the repair of generators required because of normal wear, accident, misuse, abuse, improper installation, lack of maintenance, unauthorized modifications or improper storage.

Normal Wear: This warranty will not cover repair where normal use has exhausted the life of a part or generator. It should be remembered that the service life of any generator is dependent on the care it receives and the conditions under which it has to operate. Some applications are very often used in dusty or dirty conditions, which can cause what appears to be excessive wear. Such wear, when caused by dirt, dust, grit or other abrasive material, which has entered the generator because of improper maintenance, is not covered by Warranty.

For all product lines, the engine manufacturer warrants engine systems. Contact Baldor Generators for current engine warranties.

Owner's Responsibilities:

The owner is obligated to operate and maintain the generator in accordance with the recommendations published by Baldor Generators in the Operator's Manual for the generator. The owner is responsible for the costs associated with maintenance and any adjustments that may be required.

The owner is responsible for payment of any of the following expenses that might be incurred as a result of a failure under the terms of this warranty:

1. Rental equipment used to replace the equipment being repaired.
2. Telephone or other communication expenses.
3. Living and travel expenses of persons performing service, except as specifically included within the terms of specific warranty.
4. The premium costs for overtime labor requested by the owner.
5. All parts transportation costs.

Limitations:

Baldor Generators is not responsible for the repair of generators required because of normal wear, accident, misuse, abuse, improper installation, lack of maintenance, unauthorized modifications or improper storage.

Normal Wear: This warranty will not cover repair where normal use has exhausted the life of a part or generator. It should be remembered that the service life of any generator is dependent on the care it receives and the conditions under which it has to operate. Some applications are very often used in dusty or dirty conditions, which can cause what appears to be excessive wear. Such wear, when caused by dirt, dust, grit or other abrasive material, which has entered the generator because of improper maintenance, is not covered by Warranty.

No person is authorized to give any other warranties or to assume any other liabilities on Baldor Generators' behalf unless made or assumed in writing by an officer of Baldor Generators and no person is authorized to give any warranties or assume any other liability on behalf of the seller unless made or assumed in writing by the seller.

Major components, such as engines, used in Baldor Generators' generator sets that are not manufactured by Baldor Generators are specifically excluded from Baldor Generators coverage and are covered separately by their respective manufacturers. Warranty terms and policies of excluded products are included with their owners information package supplied with each product.

WARNING:
CALIFORNIA PROPOSITION 65 WARNING:
Engine exhaust from this product contains chemicals known to the state of California to cause cancer, birth defects and other reproductive harm.

WARNING:
CALIFORNIA PROPOSITION 65 WARNING:
Diesel engine exhaust and some constituents are known to the state of California to cause cancer, birth defects and other reproductive harm.

WARNING:
CALIFORNIA PROPOSITION 65 WARNING:
Battery posts, terminals and related accessories are known to the state of California to cause cancer, birth defects and other reproductive harm.