











DEEP SEA ELECTRONICS

Model 5210 Installation and Configuration Instructions



Accessing the front panel config' editor

Press the configure/log  and Stop/Reset  buttons simultaneously. The LCD configure indicator  will flash to indicate that the module is in 'configuration mode'.

Release the Stop/Reset  button and the configure/log  button. The first configurable parameter is now displayed. Pressing the + or - buttons will cycle through the parameters.

 **NOTE:-** To exit the front panel configuration editor at any time, press the Stop/Reset  button. Ensure you have saved any changes you have made by pressing the  button first.



Editing an analogue value

Access the front panel config editor as detailed above. Press the +/- buttons to view the parameter you wish to change (see parameter table overleaf). Press the  button to enter adjust mode. The value to be adjusted will flash. Press the +/- buttons to adjust the parameter to the desired value. Press the  button to 'save' the value. The value will stop flashing to confirm that it has been saved. To select another value to edit, press the + button. Continuing to press the +/- buttons will cycle through the available parameters.



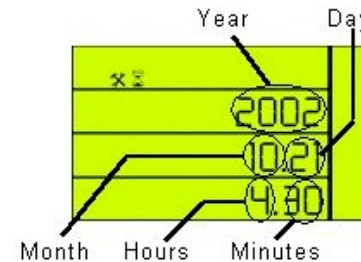



























































Editing the time

The date/time should initially be set using the 5200 series configuration software. However there may be certain circumstances where a minor change to the module's time is required. One such instance is correction for daylight saving. Access the front panel config editor as detailed above. Press the + button until the calendar is shown :



To edit the time, press the  button. The time, 4:30 in this example, will begin flashing. Press the + or - buttons to adjust the time in one minute steps until the desired time is shown. Press the  button to save the change. The time stops flashing to confirm that it has been successfully stored.

Example : This display is showing a time of 4:30 on 21st October 2002.

Config' Section	Parameter	Type	Icons displayed	
Analogue senders	Low Pressure	Pre Alarm	 	
	Low Pressure	Trip	 	
	High Temperature	Pre Alarm	 	
	High Temperature	Trip	 	
	Low Fuel Level %	Pre Alarm	 	
Calendar	Date/time	Date/time		
Timers	Start delay	Timer (secs)	2 	
	Preheat	Timer (secs)	3 	
	Crank attempt	Timer (secs)	4 	
	Crank rest	Timer (secs)	5 	
	Safety delay	Timer (secs)	6 	
	Overspeed overshoot	Timer (secs)	7 	
	Warming up	Timer (secs)	8 	
	Return delay	Timer (secs)	10 	
	Cooling run	Timer (secs)	11 	
	E.T.S.(Energise to stop) solenoid hold	Timer (secs)	12 	
	Generator output	Generator Under Voltage L1-N	Trip	  
		Generator Under Voltage L1-N	Pre Alarm	  
Generator Over Voltage		Pre Alarm	  	
Generator Over Voltage		Trip	  	
Generator Under Frequency		Trip	  	
Generator Under Frequency		Pre Alarm	  	
Generator Over Frequency		Pre Alarm	  	
Generator Over Frequency		Trip	  	
Delayed Overcurrent %		Trip	  	
Engine speed	Under Speed (RPM)	Trip	 	
	Under Speed (RPM)	Pre Alarm	 	
	Over Speed (RPM)	Pre Alarm	 	
	Over Speed (RPM)	Trip	 	
DC Voltages	Low DC Voltage	Warning	 	
	High DC Voltage	Warning	 	
	Charge Alternator Failure	Warning	 	

Deep Sea Electronics Plc.
 Highfield House, Hunmanby
 Industrial Estate, North Yorkshire.
 YO14 0PH. ENGLAND
 Tel:+44 (0)1723 890099.
 Fax: +44 (0)1723 893303.
 Email: sales@deepseapl.com

Deep Sea Electronics inc.
 5301 E. State St. – Suite 202
 Rockford, Illinois 61108
 U.S.A.
 Phone: +1 (815) 316-8706
 Fax: +1 (815) 316-8708
 Email: dsesales@deepseausa.com

NOTE: Full configuration of the 5210 module is possible using the 5200 series configuration software for PC in conjunction with the P810 interface.

Typical wiring diagram

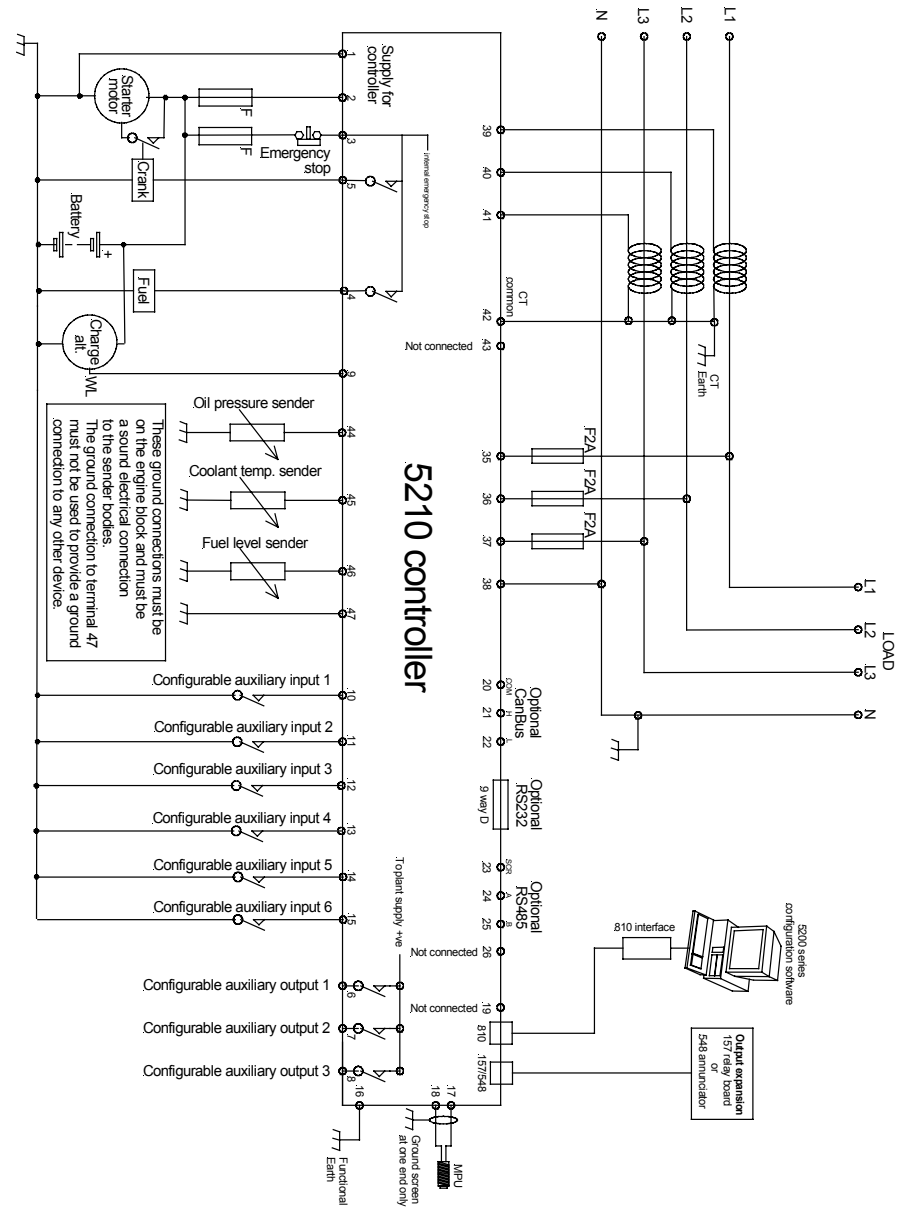

Dimensions

Module Dimensions - 240mm x 172mm x 57mm (9.45" x 6.77" x 2¼")
Panel cutout - 220mm x 160mm (8.7" x 6.3")

Alternative AC wiring

2 phase, 3 wire (2 phase centre tap neutral)

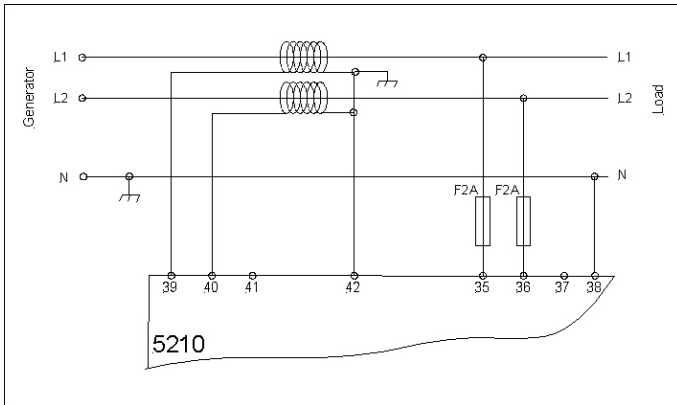

3 phase, 3 wire

