

**For 15H and 15V Controls** (Software versions S15H-5.10.AB1 and S15V-5.10.AB1)

Allows By-Pass operation of Inverter control (15H or 15V). The information provided in this document shows how to connect customer provided interface circuits to the inverter control to fully use the hardware and software capabilities of this custom feature.

**Figure 1 Three Phase AC Power and Motor Connections**

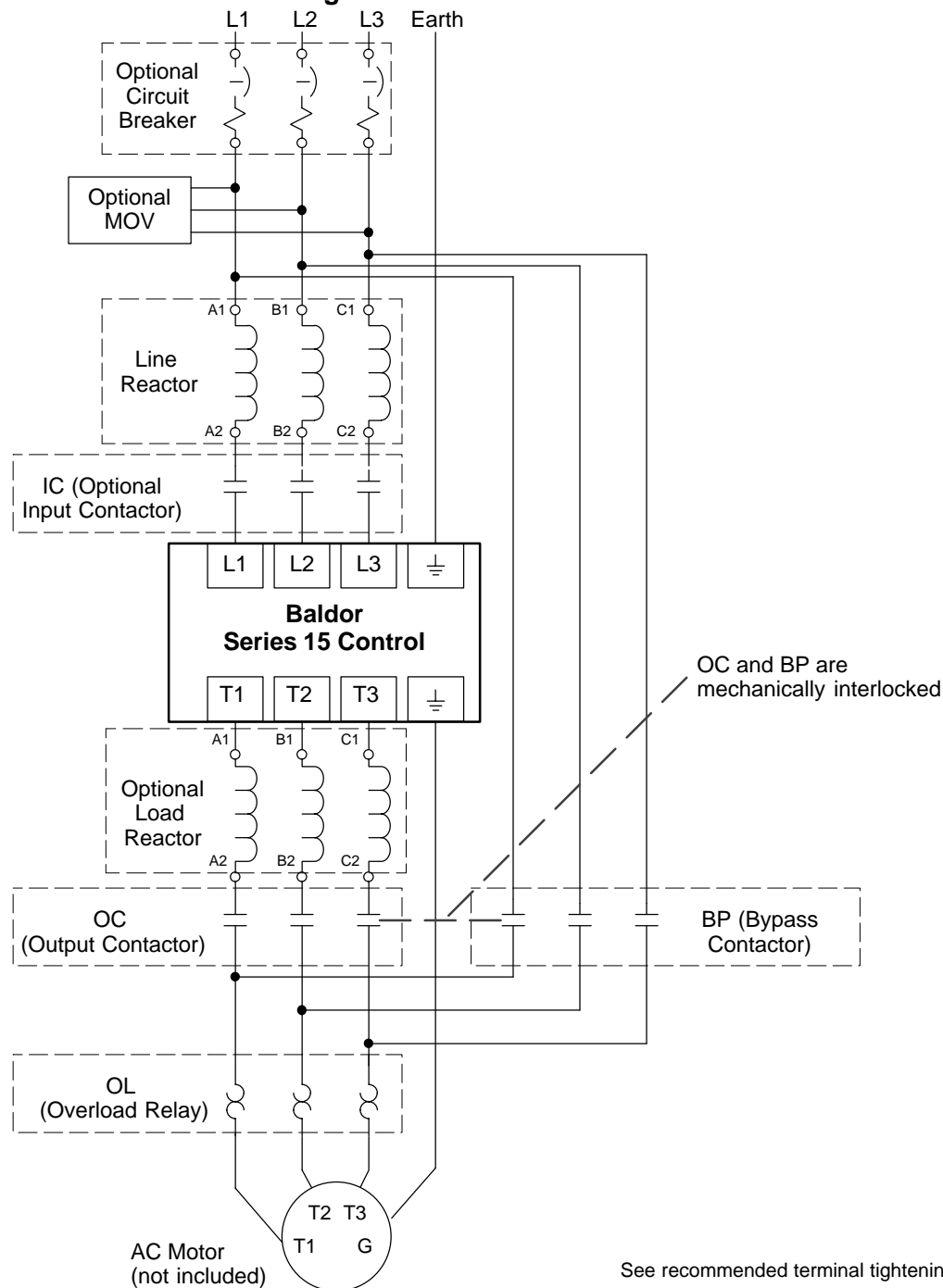

**Figure 2 J4 Connection Diagram**

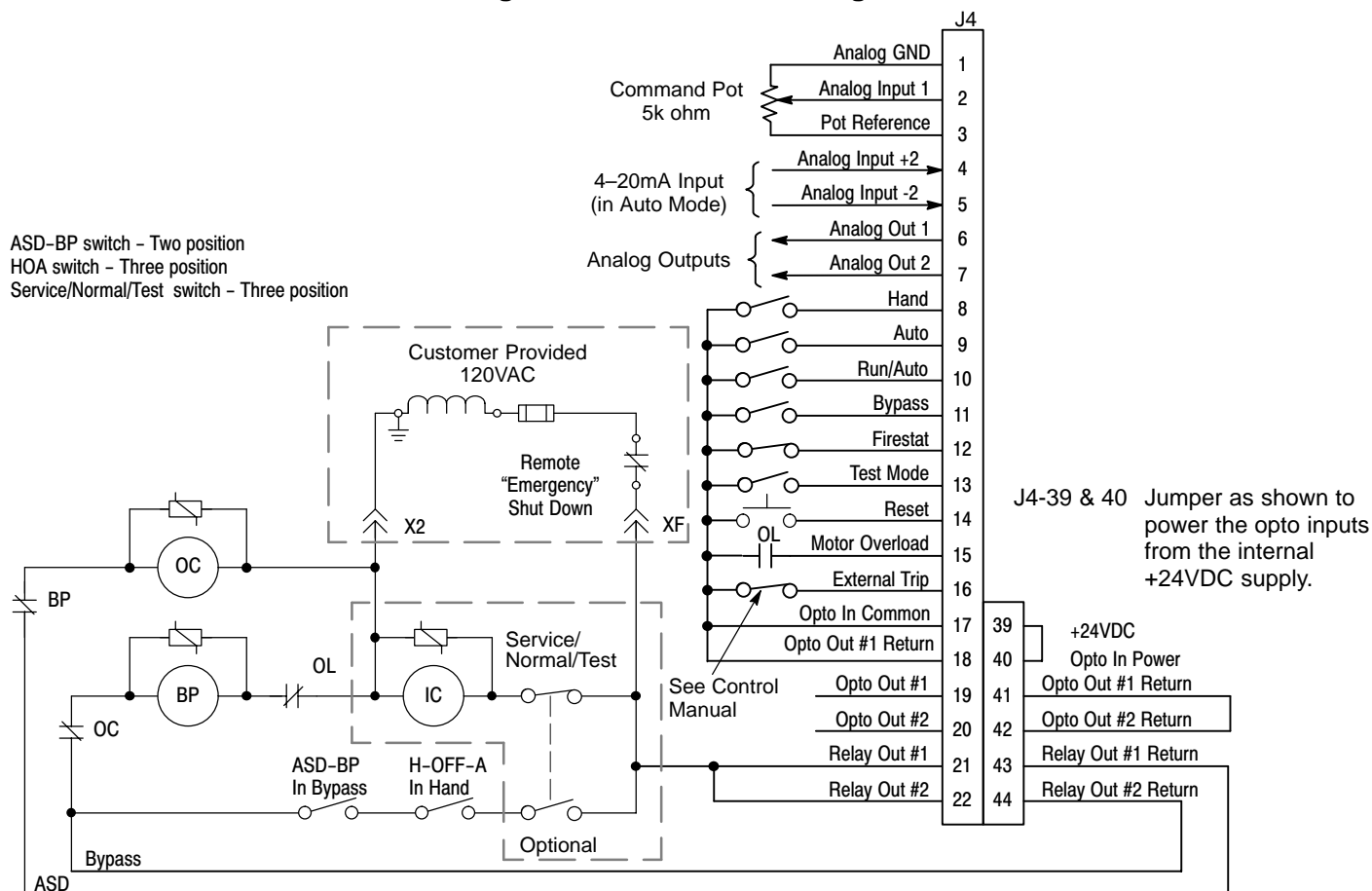

See recommended terminal tightening torques in Section 6 of control manual.

Note: J4-18 and J4-41 are connected together on the control circuit board.

- J4-8      CLOSED starts forward motor operation as described in Table 1.  
OPEN motor decels to stop depending on Keypad Stop Mode.
- J4-9      CLOSED enables automatic start (if J4-10 closed) as described in Table 1.  
OPEN motor decels to stop depending on Keypad Stop Mode.
- J4-10     CLOSED starts forward motor operation in Bypass or Inverter mode (if J4-9 closed).  
OPEN motor decels to stop depending on Keypad Stop Mode.
- J4-11     CLOSED opens output contactor (OC), closes bypass contactor (BP). Time delay and transfer sequence is not programmable.  
OPEN opens bypass contactor (BP), closes output contactor (OC). Stop and transfer sequence is not programmable.
- J4-12     CLOSED allows normal operation.  
OPEN Firestat, selects Level 1, Preset Speed #1.
- J4-13     CLOSED enables test mode.  
OPEN allows normal operation.
- J4-14     CLOSED to reset a fault condition.  
OPEN allows normal operation.
- J4-15     CLOSED disables the control and motor coasts to a stop.  
OPEN allows normal operation.
- J4-16     If J4-16 is connected, you must set Level 2 Protection block, External Trip to "ON" to activate the opto input.  
CLOSED allows normal control operation.  
OPEN causes an external trip fault. The control will disable and the motor coasts to a stop. An external trip fault is displayed (also logged in the fault log).

**Table 1 Hand – Off – Auto Switch Operation**

J4-8	J4-9	Function
Open	Open	Control disabled and motor coasts to a stop.
Open	Closed	Controlled starting is enabled. Automatic start occurs when J4-10 input is closed.
Closed	Open	Controlled starts and if not in bypass mode, motor speed is controlled by Command Pot (Analog 1 input).
Closed	Closed	Invalid condition (not allowed)

**Parameter Values** (Software versions S15H-5.10.AB1 and S15V-5.10.AB1)

**Table 2 Parameter Block Values Level 1**

Level 1 Blocks					
Block Title	Parameter	P#	Adjustable Range	Factory Setting	User Setting
INPUT	Operating Mode	1401	HOA 2-W BYPASS	HOA 2-W BYPASS	
OUTPUT	Digital Output #3	1503	ASD	ASD	
	Digital Output #4	1504	BYP	BYP	

