



**Isolated Input/Output
Relay Board**

Catalog No. ACB003A01

Installation and Operating Manual

4/01

MN1325

Table of Contents

Section 1	
General Information	1-1
Limited Warranty	1-1
Safety Notice	1-2
Section 2	
Expansion Board Description	2-1
Introduction	2-1
Description	2-1
Section 3	
Installation	3-1
Section 4	
Hardware Setup	4-1
Appendix A	
Relay Only Board	A-1



Section 1

General Information

Limited Warranty

For a period of two (2) years from the date of original purchase, BALDOR will repair or replace without charge controls and accessories which our examination proves to be defective in material or workmanship. This warranty is valid if the unit has not been tampered with by unauthorized persons, misused, abused, or improperly installed and has been used in accordance with the instructions and/or ratings supplied. This warranty is in lieu of any other warranty or guarantee expressed or implied. BALDOR shall not be held responsible for any expense (including installation and removal), inconvenience, or consequential damage, including injury to any person or property caused by items of our manufacture or sale. (Some states do not allow exclusion or limitation of incidental or consequential damages, so the above exclusion may not apply.) In any event, BALDOR's total liability, under all circumstances, shall not exceed the full purchase price of the control. Claims for purchase price refunds, repairs, or replacements must be referred to BALDOR with all pertinent data as to the defect, the date purchased, the task performed by the control, and the problem encountered. No liability is assumed for expendable items such as fuses.

Goods may be returned only with written notification including a BALDOR Return Authorization Number and any return shipments must be prepaid.

Safety Notice

This equipment contains voltages that may be as great as 1000 volts! Electrical shock can cause serious or fatal injury. Only qualified personnel should attempt the start-up procedure or troubleshoot this equipment.

This equipment may be connected to other machines that have rotating parts or parts that are driven by this equipment. Improper use can cause serious or fatal injury. Only qualified personnel should attempt the start-up procedure or troubleshoot this equipment.

PRECAUTIONS

⚠ WARNING: Do not touch any circuit board, power device or electrical connection before you first ensure that power has been disconnected and there is no high voltage present from this equipment or other equipment to which it is connected. Electrical shock can cause serious or fatal injury. Only qualified personnel should attempt the start-up procedure or troubleshoot this equipment.

⚠ WARNING: Be sure that you are completely familiar with the safe operation of this equipment. This equipment may be connected to other machines that have rotating parts or parts that are controlled by this equipment. Improper use can cause serious or fatal injury. Only qualified personnel should attempt the start-up procedure or troubleshoot this equipment.

⚠ WARNING: Do not remove cover for at least five (5) minutes after AC power is disconnected to allow capacitors to discharge. Dangerous voltages are present inside the equipment. Electrical shock can cause serious or fatal injury.

⚠ WARNING: Improper operation of control may cause violent motion of the motor shaft and driven equipment. Be certain that unexpected motor shaft movement will not cause injury to personnel or damage to equipment. Peak torque of several times the rated motor torque can occur during control failure.

Section 2

Accessory Board Description

Introduction

The Isolated Input/Output Board converts high level AC or DC input voltage levels to the proper range for the motor control board. The inputs are used to command the ON and OFF states of the digital command inputs of the Motor Control Board.

This board has no group1 or group2 expansion board connectors. There are no connectors other than a prewired harness for connections to the motor control board.

Catalog No. ACB003A01
9 Optically Isolated Inputs
2 Relay Outputs

Note: This accessory board is compatible with 17H, 18H, 21H, 22H and 23H controls. It is compatible with 15H controls that have terminals J4–39 to J4–44 (internal 24VDC logic supply).

Description

OPTO – INPUTS (9 each), terminals 1–5 & 9–13 (9 is common)

Input voltage:	40 – 100 VDC, 90 – 125VAC
Input Impedance:	20kohm
Leakage Current (All Opto Inputs OFF):	50 μ A, Max
Response time	70msec, Max
Wire Gauge	26 – 16 AWG

RELAY–OUTPUTS (2 each), terminals 6–8 & 14–16

Contact Type (each relay):	Form C (N.O.) & (N.C.) with common
Contact Rating:	5A at 230VAC (non–inductive)
Operating Time:	10 msec, Max
Release Time:	5 msec, Max
Wire Gauge	26 – 16 AWG

Section 3 Installation

Compatibility

Table 3-1 defines the H Series expansion boards that are compatible with and can be installed with this board (indicated by Yes). The EXB's that are not compatible with this board (indicated by No) have a conflict of operation or mechanical or other interference.

Table 3-1 EXB's Compatible with ACB003

Expansion Board	Enclosure Size			
	A	B	B2	C2 *
Isolated Input	No	No	No	No
Master Pulse Reference	No	No	No	No
DC Tach	Yes	Yes	Yes	No
Isolated Encoder	Yes	Yes	Yes	No
Resolver to Digital	Yes	Yes	Yes	No
RS232	Yes	Yes	Yes	No
RS422/485	Yes	Yes	Yes	No
Pneumatic Input/Relay Output	No	No	No	No
High Resolution Analog	Yes	Yes	Yes	No
3 Relay/2 Analog Out	Yes	Yes	Yes	No
RS232/485 High Speed	Yes	Yes	Yes	No

* For a C2 size enclosure only the ACB003 board can be installed. If the ACB003 board is installed, no other EXB's are compatible.

Board Installation

⚠ Caution: Before you proceed, be sure to read and become familiar with the safety precautions at the beginning of this manual. Do not proceed if you are unsure of the safety precautions described. If you have any questions, contact BALDOR before you proceed.

1. Remove the board from the shipping container.
2. Remove all packing material from the board.

⚠ Caution: Be sure all packing materials are removed from the board. Conductive foam may be present on the connectors to prevent static build up during shipping. This can prevent proper circuit operation.

Single Board Installation

Procedure:

1. Be sure drive operation is terminated and secured.
2. Remove all power sources from the control.
3. Wait at least 5 minutes for internal capacitors to discharge.
4. Remove or open the control cover.
5. Place the board on the sheet metal mounting plate as shown in Figures 3-1 and 3-2.
6. Secure the board to the mounting plate using steel and plastic screws in the correct locations indicated in Figure 3-1.
7. The mechanical installation of the board is now complete. Refer to Section 4 of this manual and complete the wiring before you proceed to step 8.
8. When complete, install or close the control cover.
9. Restore all power sources to the control.
10. Restore drive operation.

Single Board Installation (Continued)

Figure 3-1 Single Board Installation

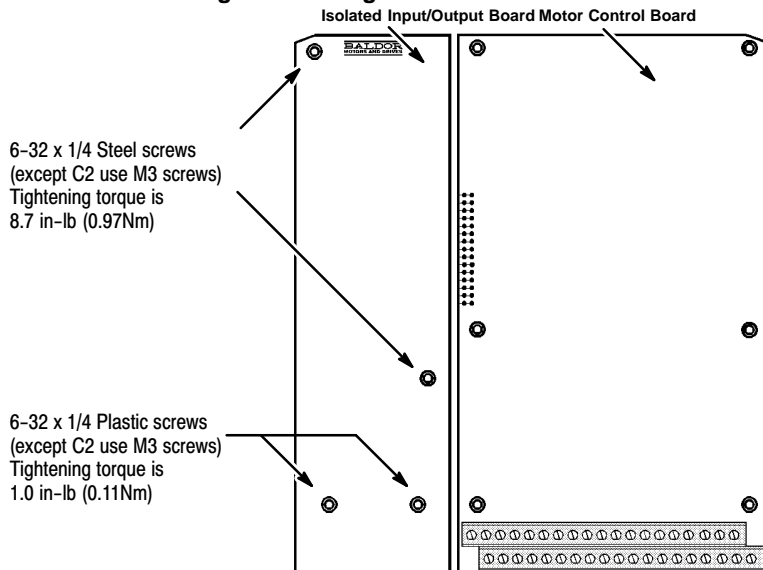

Terminal tightening torque is 7 lb-in (0.8 Nm) maximum.

Figure 3-2 Single Board Installation

6-32 x 1/4 (except for
C2 use M3 screws)

Tighten Steel screws to
8.7 in-lb (0.97Nm)
plastic screws to
1.0 in-lb (0.11Nm)

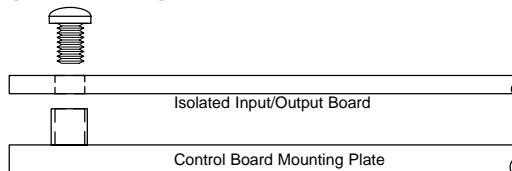

Two Board Installation

Procedure:

1. Be sure drive operation is terminated and secured.
2. Remove all power sources from the control.
3. Wait at least 5 minutes for internal capacitors to discharge.
4. Remove or open the control cover.
5. Place the group 1 or 2 expansion board on the sheet metal mounting plate as shown in Figure 3-1 and 3-3.
6. Secure the board to the mounting plate using short standoffs provided as indicated in Figure 3-3.
7. The mechanical installation of the expansion board is now complete. Refer to the manual for the Group 1 board and configure the jumpers as desired. Also complete the wiring for this board before you proceed to step 8.
8. Place the Isolated Input/Output board on top of the previously installed Group 1 or 2 board and align its mounting holes with the standoffs.
9. Secure the board to the standoffs using steel and plastic screws in the correct locations indicated in Figure 3-1 and 3-3.
10. The mechanical installation of the board is now complete. Refer to Section 4 of this manual and complete the wiring for this board before you install or close the cover.
11. When complete, install or close the control cover.
12. Restore all power sources to the control.
13. Restore drive operation.

Figure 3-3 Two Board Installation

6-32 x 1/4 (except for
C2 use M3 screws)

Short Plastic
Standoff

Tighten Steel screws to
8.7 in-lb (0.97Nm)
plastic screws to
1.0 in-lb (0.11Nm)

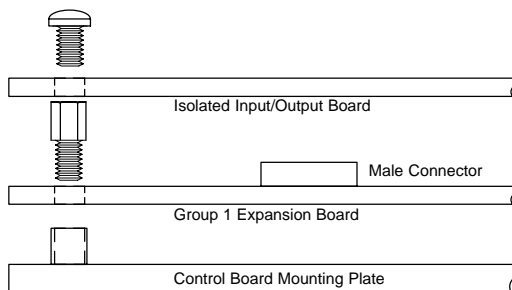

Section 4 Hardware Setup

Isolated Input/Output Relay Board

Figure 4-1 illustrates the external connections for operation. No jumpers are required on this board.

Note: This accessory board is compatible with 17H, 18H, 21H, 22H and 23H controls. It is compatible with 15H controls that have terminals J4–39 to J4–44.

Inputs 1 – 9 at connector J1 allow 115VAC connections to external systems. J1 shown in Figure 4-1 is the only terminal strip for making opto input connections to external wiring. A wiring harness attached to the board connects to the opto inputs of the motor control board. After installation, all digital inputs, Digital Output #3 and Digital Output #4 are made at the J1 connector of the accessory board.

Figure 4-1 External Connections

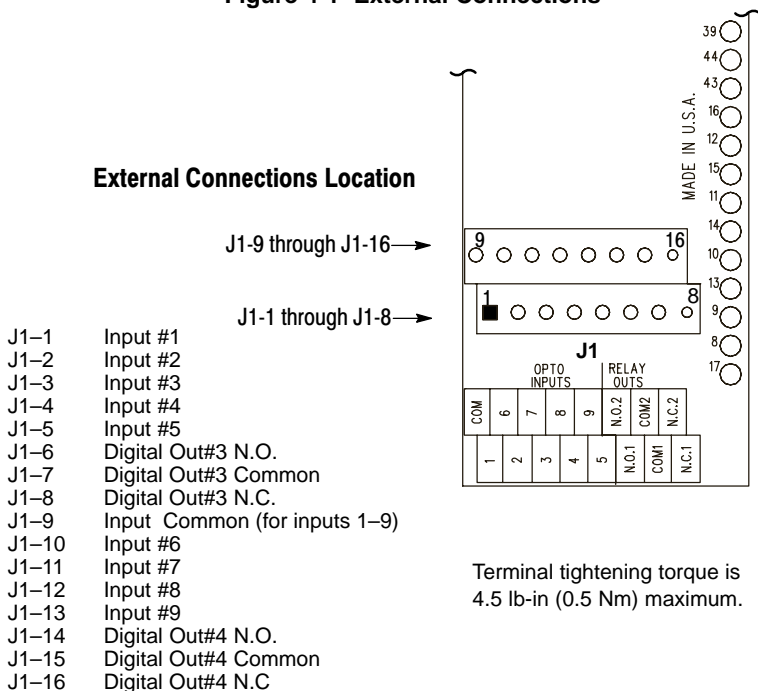

Figure 4-2 illustrates the connections between the accessory board and the control board (J1 or J4 terminal strip).

A wire harness is soldered onto each of the connections on the accessory board. The other end of each wire is dressed into a harness and terminated with a crimp on connector. Each wire is labeled with the terminal number of the motor control (J1 or J4) connector that it is to be connected to. These connections are shown in Table 4-1. After these connections are made, verify that both jumpers (included with the harness) shown in Figure 4-2 are connected.

Note: The diagnostic screens (Digital I/O) can be used to verify proper operation of the inputs. Refer to the motor control manual.

Figure 4-2 Control Internal Connections

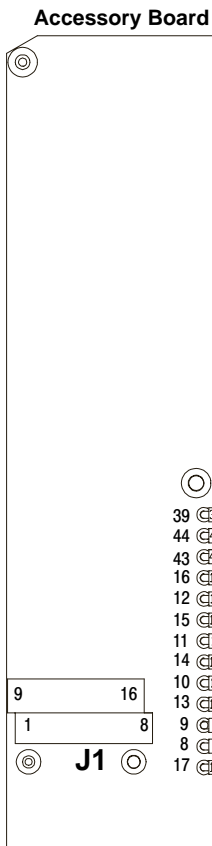
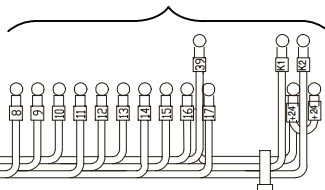

Table 4-1 Interconnections

Accessory Board	Control Board (J1 or J4)
39	39
44	44 (K2)
43	43 (K1)
17	17
16	16
15	15
14	14
13	13
12	12
11	11
10	10
9	9
8	8

Note: Two jumpers are installed at the J1 or J4 terminal strip as shown here. They are:
 J4-21 to J4-22 (+24 to +24)
 J4-39 to J4-21 (39 to +24)

To J1 or J4 Control Terminal Strip



Terminal tightening torque is 4.5 lb-in (0.5 Nm) maximum.

CD1456



Appendix A

Relay Only Board

Output Relay Only Board

The special relay only configuration of this board is shown in Figures A-1 and A-2. No jumpers are required on this board.

Note: This accessory board is compatible with 17H, 18H, 21H, 22H and 23H controls. It is compatible with 15H controls that have terminals J4–39 to J4–44 (internal 24VDC logic supply).

External wiring connections are made only at J1 shown in Figure A-1. A wiring harness attached to the board connects to the motor control board. After installation, Digital Output #3 and Digital Output #4 are made at the J1 connector of the accessory board.

Figure A-1 External Connections

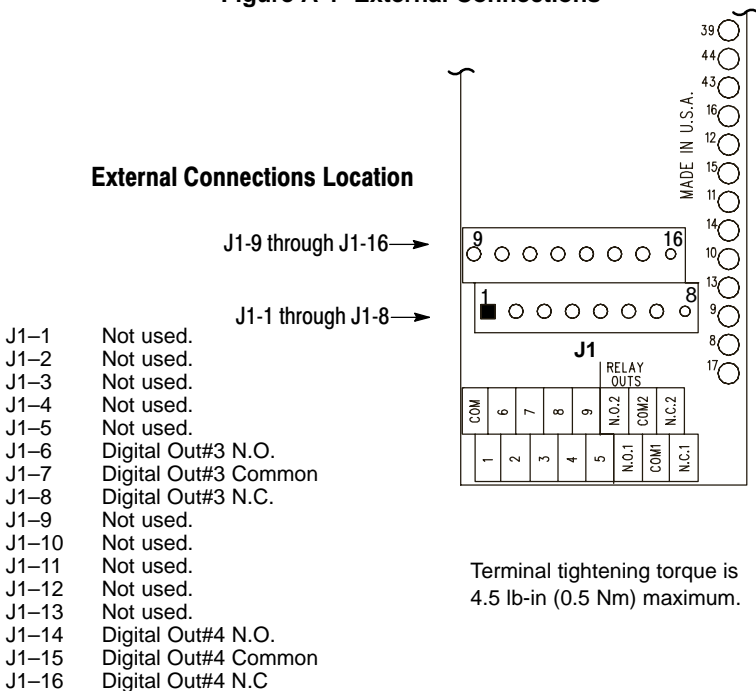

Figure A-2 shows the connections between the accessory board and the control board (J1 or J4 terminal strip). A wire harness is soldered onto each of the connections on the accessory board. The other end of each wire is dressed into a harness and terminated with a crimp on connector. Each wire is labeled with the terminal number of the motor control (J1 or J4) connector that it is to be connected to. These connections are shown in Table A-1. After these connections are made, verify that both jumpers (included with the harness) shown in Figure A-2 are connected.

Note: The diagnostic screens (Digital I/O) can be used to verify proper operation of the inputs. Refer to the motor control manual.

Figure A-2 Control Internal Connections

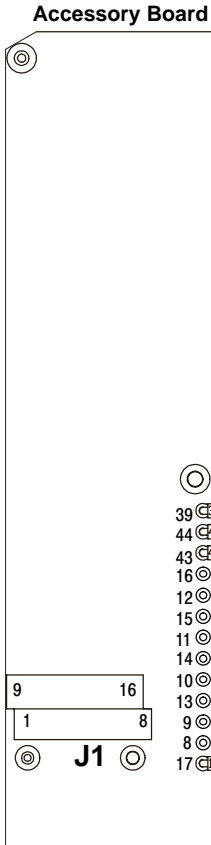
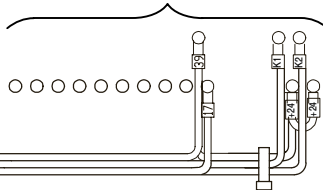

Table A-1 Interconnections

Accessory Board	Control Board (J1 or J4)
39	39
44	44 (K2)
43	43 (K1)
17	17

Note: Two jumpers are installed at the J1 or J4 terminal strip as shown here. They are:
 J4-21 to J4-22 (+24 to +24)
 J4-39 to J4-21 (39 to +24)

To J1 or J4 Control Terminal Strip



CD1456

Terminal tightening torque is 4.5 lb-in (0.5 Nm) maximum.

Figure A-3 Relay Output Connections

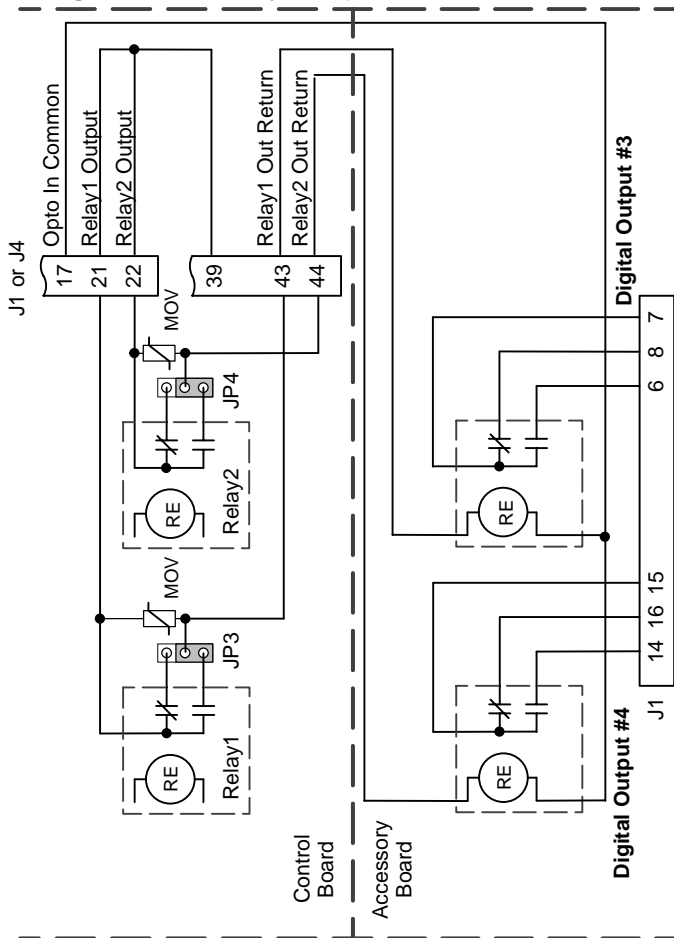

BALDOR[®]
MOTORS AND DRIVES

BALDOR ELECTRIC COMPANY
P.O. Box 2400
Fort Smith, AR 72902-2400
(501) 646-4711
Fax (501) 648-5792

© Baldor Electric Company
MN1325

Printed in USA
4/01 C&J1000