

The logo for BALDOR, featuring the word "BALDOR" in a bold, sans-serif font with a registered trademark symbol (®) at the end. The text is centered between two thick horizontal bars.

**BALDOR®**



**Profibus DP  
Expansion Board**

Catalog No. EXB014A01

**Installation and Operating Manual**

8/03

MN1323

# Table of Contents

---

<b>Section 1</b>	
<b>General Information</b> .....	1-1
Introduction .....	1-1
Limited Warranty .....	1-2
Safety Notice .....	1-3
Precautions .....	1-3
<b>Section 2</b>	
<b>Expansion Board Description</b> .....	2-1
Introduction .....	2-1
<b>Section 3</b>	
<b>Installation</b> .....	3-1
Board Installation .....	3-1
AC Controls .....	3-2
Single Expansion Board Installation .....	3-2
Dual Expansion Board Installation .....	3-4
<b>Section 4</b>	
<b>Hardware Setup</b> .....	4-1
Connection .....	4-1
Powerup .....	4-1
LED Indicators .....	4-4
Control Terminal Strip Connections .....	4-5
<b>Section 5</b>	
<b>Data I/O Map</b> .....	5-1
Configure Control Software for Profibus Mode .....	5-1
Setting the Series H Control .....	5-2
Profibus Configuration (GSD File) .....	5-3
Data Exchange with the Profibus Expansion Board .....	5-4
Command Mode .....	5-7
Reading Drive Parameters .....	5-9
Writing Drive Parameters .....	5-10



# Section 1

## General Information

---

### Introduction

The Baldor controls represent the latest technology in microprocessor based motor controls. In addition to the user programmable parameters available in every control, many different expansion boards are available from Baldor to further customize the control to most any application.

Expansion boards are categorized by compatibility into two groups: Group 1 and Group 2, see Table 1-1. A board from either group may be used alone in a control. If two boards are to be used, one board must be from Group 1 and the other from Group 2.

Note: Using two Group 1 or two Group 2 boards in the same control is not allowed.

**Table 1-1 Group 1 and Group 2 Board Categories**

<b>Group 1 Board Name</b>	<b>Catalog No.</b>	<b>Manual No.</b>
Isolated Input	EXB003A0X	MN1314
Master Pulse Reference/ Isolated Pulse Follower	EXB005A0X	MN1312
DC Tachometer Interface	EXB006A0X	MN1311
Isolated Encoder	EXB008A0X	MN1317
Resolver to Digital Interface	EXB009A0X	MN1313
<b>Group 2 Board Name</b>		
RS-232 Serial	EXB001A0X	MN1310
RS-422/RS-485 Serial	EXB002A0X	MN1310
RS-232/485 Serial	EXB012A0X	MN1310
Four Output Relays/3-15 PSI Pneumatic	EXB004A0X	MN1315
High Resolution Analog I/O	EXB007A0X	MN1316
2 Isolated Analog Output/ 3 Relay Output	EXB010A0X	MN1319
Device Net	EXB013A0X	MN1320
Profibus	EXB014A0X	MN1323
Modbus Plus	EXB015A0X	MN1322

---

## **Limited Warranty**

For a period of two (2) years from the date of original purchase, BALDOR will repair or replace without charge controls and accessories which our examination proves to be defective in material or workmanship. This warranty is valid if the unit has not been tampered with by unauthorized persons, misused, abused, or improperly installed and has been used in accordance with the instructions and/or ratings supplied. This warranty is in lieu of any other warranty or guarantee expressed or implied. BALDOR shall not be held responsible for any expense (including installation and removal), inconvenience, or consequential damage, including injury to any person or property caused by items of our manufacture or sale. (Some states do not allow exclusion or limitation of incidental or consequential damages, so the above exclusion may not apply.) In any event, BALDOR's total liability, under all circumstances, shall not exceed the full purchase price of the control. Claims for purchase price refunds, repairs, or replacements must be referred to BALDOR with all pertinent data as to the defect, the date purchased, the task performed by the control, and the problem encountered. No liability is assumed for expendable items such as fuses.

Goods may be returned only with written notification including a BALDOR Return Authorization Number and any return shipments must be prepaid.

---

## **Safety Notice**

This equipment contains voltages that may be as great as 1000 volts! Electrical shock can cause serious or fatal injury. Only qualified personnel should attempt the start-up procedure or troubleshoot this equipment.

This equipment may be connected to other machines that have rotating parts or parts that are driven by this equipment. Improper use can cause serious or fatal injury. Only qualified personnel should attempt the start-up procedure or troubleshoot this equipment.

## PRECAUTIONS

- ⚠ WARNING: Do not touch any circuit board, power device or electrical connection before you first ensure that power has been disconnected and there is no high voltage present from this equipment or other equipment to which it is connected. Electrical shock can cause serious or fatal injury. Only qualified personnel should attempt the start-up procedure or troubleshoot this equipment.**
- ⚠ WARNING: Be sure that you are completely familiar with the safe operation of this equipment. This equipment may be connected to other machines that have rotating parts or parts that are controlled by this equipment. Improper use can cause serious or fatal injury. Only qualified personnel should attempt the start-up procedure or troubleshoot this equipment.**

- 
- ⚠ WARNING:** Be sure the system is properly grounded before applying power. Do not apply AC power before you ensure that all grounding instructions have been followed. Electrical shock can cause serious or fatal injury.
- ⚠ WARNING:** Do not remove cover for at least five (5) minutes after AC power is disconnected to allow capacitors to discharge. Dangerous voltages are present inside the equipment. Electrical shock can cause serious or fatal injury.
- ⚠ WARNING:** Improper operation of control may cause violent motion of the motor shaft and driven equipment. Be certain that unexpected motor shaft movement will not cause injury to personnel or damage to equipment. Peak torque of several times the rated motor torque can occur during control failure.
- ⚠ WARNING:** Motor circuit may have high voltage present whenever AC power is applied, even when motor is not rotating. Electrical shock can cause serious or fatal injury.
- ⚠ Caution:** To prevent equipment damage, be certain that the electrical service is not capable of delivering more than the maximum line short circuit current amperes listed in the appropriate control manual, 230 VAC, 460 VAC or 575 VAC maximum per control rating.

## **Section 2**

# **Expansion Board Description**

---

### **Introduction**

The Profibus expansion board is a Group 2 expansion board. It allows a Series H control to communicate as a node on the Profibus network. It has a DB9 connector to make connection to the network simple.

Group 2 board  
Profibus Expansion Board  
Catalog No. EXB014A01



## Section 3

# Installation

---

### Board Installation

This section describes the Expansion Board installation procedure.

**⚠ Caution:** Before you proceed, be sure to read and become familiar with the safety precautions at the beginning of this manual. Do not proceed if you are unsure of the safety precautions described. If you have any questions, contact BALDOR before you proceed.

1. Remove the expansion board from the shipping container.
2. Remove all packing material from the board.

**⚠ Caution:** Be sure all packing materials are removed from the board. Conductive foam may be present on the connectors to prevent static build up during shipping. This can prevent proper circuit operation.

If you are installing only one board, refer to the “Single Expansion Board Installation” procedure. If you are installing two expansion boards (or a second board) refer to the “Dual Expansion Board Installation” procedure.

---

## AC Controls

(For all 15H Inverter, 21H Line Regen Inverter, 18H Vector, 22H Line Regen Vector and 23H Servo).

### **Single Expansion Board Installation**

Procedure:

1. Be sure drive operation is terminated and secured.
2. Remove all power sources from the control.
3. Wait at least 5 minutes for internal capacitors to discharge.
4. Remove the four (4) Phillips head screws ( $1/4$  turn) that secure the control cover. (For A & B size, remove four screws that secure the cover. On floor mounted G size enclosures, open the enclosure door).
5. Remove the control cover.
6. Slide the expansion board male connector into the female connector of the control board. See Figure 3-1.
7. Securely mount the expansion board to the sheet metal mounting plate using the #6 screws provided in the installation hardware. See Figure 3-2.
8. The mechanical installation of the expansion board is now complete. Refer to Section 4 of this manual and configure the jumpers as desired. Also complete the wiring before you proceed to step 9.
9. When complete, install the control cover using the four (4) Phillips head screws ( $1/4$  turn). (For A & B size, install four screws that secure the cover. On floor mounted G size enclosures, close the enclosure door).
10. Restore all power sources to the control.
11. Restore drive operation.

---

## AC Controls

### Single Expansion Board Installation (Continued)

**Figure 3-1 Single Expansion Board Installation**

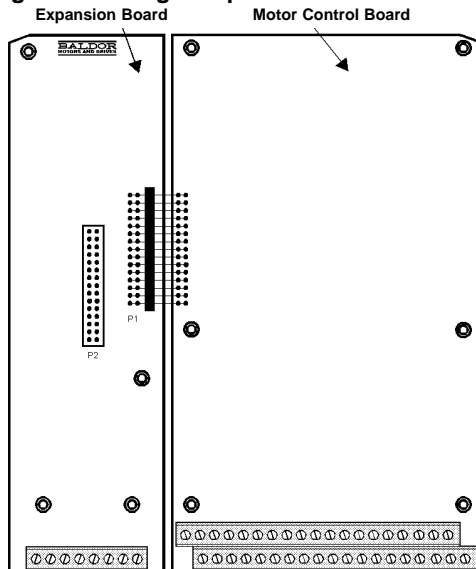

Terminal tightening torque is 7 lb-in (0.8 Nm) maximum.

**Figure 3-2 Single Expansion Board Installation**

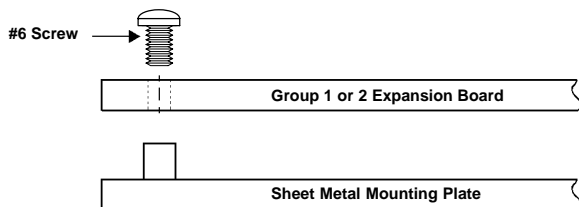

---

## **AC Controls (Continued)**

### ***Dual Expansion Board Installation***

Procedure:

1. Be sure drive operation is terminated and secured.
2. Remove all power sources from the control.
3. Wait at least 5 minutes for internal capacitors to discharge.
4. Remove the four (4) Phillips head screws ( $\frac{1}{4}$  turn) that secure the control cover. (For A & B size, remove four screws that secure the cover. On floor mounted G size enclosures, open the enclosure door).
5. Remove the control cover.
6. Slide the Group 1 expansion board male connector into the female connector of the control board. See Figure 3-1.
7. Securely mount the Group 1 expansion board to the sheet metal mounting plate using the short standoffs provided in the installation hardware. See Figure 3-3.
8. The mechanical installation of the expansion board is now complete. Refer to the manual for the Group 1 board and configure the jumpers as desired. Also complete the wiring before you proceed to step 9.
9. Install the Group 2 board on top of the previously installed Group 1 board by plugging the female connector onto the male connector of the Group 1 board as shown in Figure 3-3.
10. Secure this Group 2 board to the Group 1 board using the #6 screws provided. See Figure 3-3.
11. The mechanical installation of the expansion board is now complete. Refer to the manual for the Group 2 board and configure any jumpers and switches as desired. Also complete the wiring for this board before you install or close the cover.

---

## AC Controls

### *Dual Expansion Board Installation (Continued)*

- When complete, install the control cover using the four (4) Phillips head screws ( $\frac{1}{4}$  turn). (For A & B size, install four screws that secure the cover. On floor mounted G size enclosures, close the enclosure door).
- Restore all power sources to the control.
- Restore drive operation.

**Figure 3-3 Dual Expansion Board Installation**

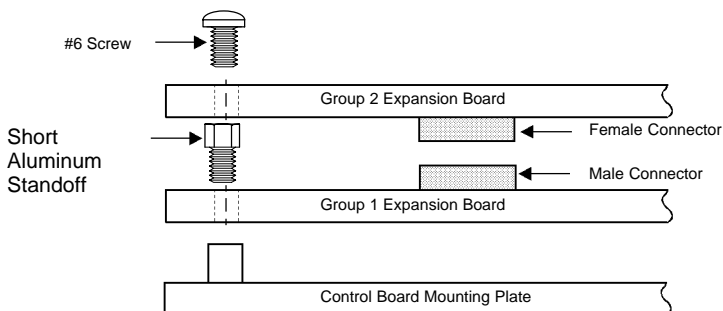



## Section 4 Hardware Setup

---

### **Connection**

1. Install the Profibus circuit board as instructed in Section 3 of this manual.
2. The H Series control software must be updated to allow Profibus operation. For 15H controls, the software must be S15–4.03 or higher. For 18H controls, the software must be S18–3.12 or higher.
3. Connect the Profibus cable to the DB 9 connector on the expansion board (shown in Figure 4-1).
4. Set the S1 switches on the Profibus board for the correct Profibus address (0–125). See Table 4-1. Note that the “0” switch position is toward the circuit board.

### **Powerup**

When the Profibus expansion board is powered up it will do the following:

1. Perform a self test.
2. Check the switch settings for configuration information.
3. Verify communications with the Series H control board.
4. Check for power from the Series H control.
5. Perform a duplicate ID (address) check to determine if any other devices on the network have the same ID number.
6. Go online.

Refer to the LED description in this section of the manual.

---

## Figure 4-1 Board Configuration

Profibus Expansion Board Catalog No. EXB014A01

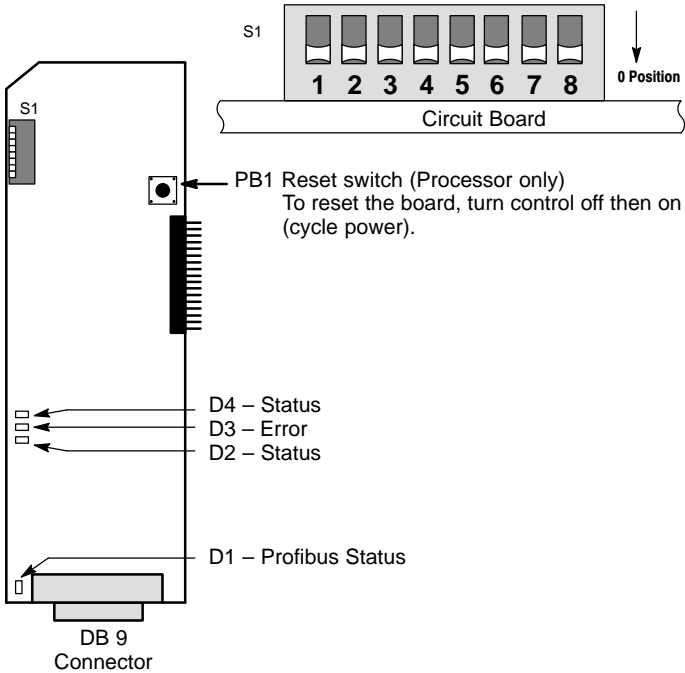

**Table 4-1 Switch Settings**

Profibus Address	S1 Switch Position						
	1	2	3	4	5	6	7
0	0	0	0	0	0	0	0
1	1	0	0	0	0	0	0
2	0	1	0	0	0	0	0
3	1	1	0	0	0	0	0
4	0	0	1	0	0	0	0
5	1	0	1	0	0	0	0
6	0	1	1	0	0	0	0
7	1	1	1	0	0	0	0
8	0	0	0	1	0	0	0
9	1	0	0	1	0	0	0
10	0	1	0	1	0	0	0
11	1	1	0	1	0	0	0
12	0	0	1	1	0	0	0
13	1	0	1	1	0	0	0
14	0	1	1	1	0	0	0
15	1	1	1	1	0	0	0
16	0	0	0	0	1	0	0
17	1	0	0	0	1	0	0
18	0	1	0	0	1	0	0
19	1	1	0	0	1	0	0
20	0	0	1	0	1	0	0
21	1	0	1	0	1	0	0
22	0	1	1	0	1	0	0
23	1	1	1	0	1	0	0
24	0	0	0	1	1	0	0
25	1	0	0	1	1	0	0
26	0	1	0	1	1	0	0
27	1	1	0	1	1	0	0
28	0	0	1	1	1	0	0
29	1	0	1	1	1	0	0
30	0	1	1	1	1	0	0
31	1	1	1	1	1	0	0
32	0	0	0	0	0	1	0
...	...	...	...	...	...	...	...
63	1	1	1	1	1	1	0
64	0	0	0	0	0	0	1
...	...	...	...	...	...	...	...
124	0	0	1	1	1	1	1
125	1	0	1	1	1	1	1

---

## LED Indicators

Four LED's are located on the Profibus expansion board (see Figure 4-1 for their locations).

### D1 Profibus Status LED

D1 displays the operating status of the Profibus connection. When power is first applied, the LED will be off. When a Profibus Host establishes communications with the Profibus EXB, the LED will go ON and will remain ON for as long as it detects Profibus host communications.

### D3 Error LED

If any errors are encountered that would prevent correct operation of the board, D3 will flash an error code. If an error occurs, turn the control off, then on (cycle power). If the error continues, contact Baldor. The error codes are shown in Table 4-2.

**Table 4-2 D3 Error Codes**

LED State	Status Description
OFF	No power is applied to the EXB.
2 Flashes then pause	The processor failed its' power-up RAM test.
3 flashes then pause	The processor failed its' power-up ROM checksum test.
4 flashes then pause	The processor is unable to communicate with the Baldor Drive.
5 flashes then pause	The processor is unable to communicate with Profibus interface chip on the EXB.

### D2 and D4 Status LED

D2 will flash to indicate that the hardware is working.

D4 will flash at a slower rate to indicate that the firmware is working.

---

## Control Terminal Strip Connections

For Serial Mode operation, the Input/Output terminal strip of the control (J1 of the Vector and DC controls and J4 of the Inverters) is wired as shown in Figure 4-2. Connect the Enable, Forward Enable Switch, Reverse Enable Switch, External Trip and Opto Common connections as shown.

Note: All opto-isolated outputs and analog outputs remain active while operating in the Serial Mode.

When these connections are complete, refer to Section 5 of this manual and set the software for Serial Mode.

**Figure 4-2 Serial Opto Input Connections**

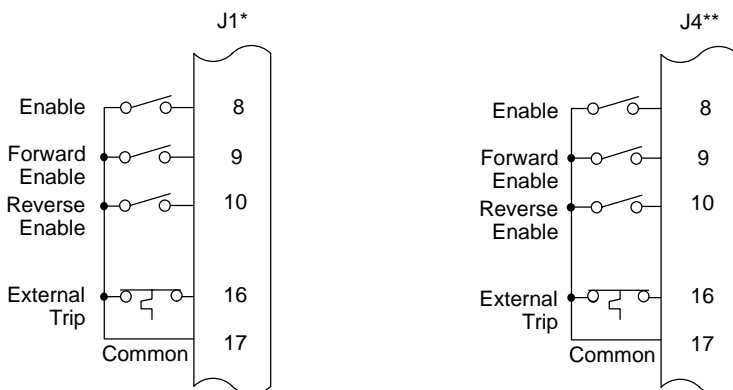

\* Series 18H, 22H and 23H controls.

\*\* Series 15H and 21H controls.



## Section 5

### Data I/O Map

---

#### **Configure Control Software for Profibus Mode**

Many commands in the Command Language can be used regardless of the setting of the control's Operating Mode parameter (such as changing and viewing parameters). However, commands intended to control the motor shaft require the Level 1 Input block Operating Mode parameter be set to Serial (Profibus) Mode and the Level 2 Communications block be set to RS485BBP.

The Series H control Operating Mode must be set to Serial to use the Profibus expansion board. There is no selection for Profibus on the Level 1 Input block Operating Mode parameter list.

**Note:** The firmware version of the Series H control must support the Baldor Binary Protocol (BBP). To confirm that BBP is supported, perform the following:

Scroll to the Level 2 Communications block, and view the selections. If RS485BBP is available, the software version is compatible with the Profibus expansion board. Otherwise, contact Baldor to obtain a software update.

During power up, the control checks if the communication board is installed. The RS485BBP protocol is automatically selected during power up.

## Setting the Series H Control

Action	Description	Display	Comments
Apply Power	Display illuminates	BALDOR MOTORS & DRIVES	Logo is displayed for 5 seconds.
	If no fault is found and control is programmed for local mode,OR,	STP MOTOR SPEED LOCAL 0RPM	Display mode.
	If no fault is found and control is programmed for remote mode	STP MOTOR SPEED REMOTE 0RPM	Display mode.
Press PROG key	Access programming mode.	PRESS ENTER FOR PRESET SPEEDS	First screen in programming mode
Press ▲ or ▼ key	Scroll to Level 1 Input block	PRESS ENTER FOR INPUT	Input Block.
Press Enter key	First selection choice	OPERATING MODE P: KEYPAD	Now in keypad mode.
Press Enter key	Flashing cursor indicates mode can be changed	OPERATING MODE ◄ □ KEYPAD	
Press ▲ or ▼ key	Scroll to Serial mode	OPERATING MODE ◄ □ SERIAL	Change to Serial mode.
Press Enter key	Saves mode change value	OPERATING MODE P: SERIAL	
Press ▲ key *	Scroll to Command Select parameter	COMMAND SELECT P: +/-10VOLTS	Now in ±10 Volt input mode.
Press * Enter key	Flashing cursor indicates mode can be changed	COMMAND SELECT ◄ □ +/-10VOLTS	
Press ▲ or ▼ key *	Scroll to Serial mode	COMMAND SELECT ◄ □ SERIAL	Change to Serial mode.
Press * Enter key	Saves change to serial command select	COMMAND SELECT P: SERIAL	Control is now in Serial mode.

\* Note: The 15H control does not have a command select "Serial", this is not needed for this control. For the 18H/23H control, the Command Select parameter need only be changed to Serial if the Profibus will send commands intended to control the motor shaft.

Action	Description	Display	Comments
Press ▲ or ▼ key	Scroll to Level 2 blocks	PRESS ENTER FOR LEVEL 2 BLOCKS	
Press ENTER key	Select Level 2 blocks.	PRESS ENTER FOR OUTPUT LIMITS	First screen in Level 2 block
Press ▲ or ▼ key	Scroll to Communications block	PRESS ENTER FOR COMMUNICATIONS	
Press ENTER key	Select Level 2 Communications block.	PROTOCOL p: RS232 ASCII	
Press Enter key	Flashing cursor indicates mode can be changed	PROTOCOL ◊ □ RS232ASCII	
Press ▲ or ▼ key	Scroll to RS 485 BBP (Baldor Binary Protocol)	PROTOCOL ◊ □ RS485BBP	
Press ENTER key	Select RS 485 BBP mode.	PROTOCOL p: RS485BBP	
Press ▲ or ▼ key	Scroll to Exit Menu	PRESS ENTER FOR MENU EXIT	

The control is now configured for Profibus mode and the Host software can now be setup.

## **Profibus Configuration**

The GSD file is used by Profibus to communicate with the BBP of the Baldor Profibus expansion board. The Baldor GSD file is provided on a diskette that is shipped with the expansion board. A Profibus configuration tool should be used to configure the expansion board.

## Data Exchange with the Profibus Expansion Board

This section describes how data is mapped for data exchange between the Profibus Host and the Series H control. Data mapping allows the Profibus Host to control the drive and monitor drive status as well as read and write drive configuration parameters.

Information from the Series H control is mapped directly to Profibus Output words. Status information is mapped directly to Profibus Input data.

Three Profibus Output data words can be used to specify drive configuration parameters to be written or read. The results of these requests are reflected in the Profibus Input data. The format of the Profibus Input / Output data is as follows:

**Table 5-1 Input Data (Series H to Profibus)**

Location		Bit 15	Bit 14	Bit 13	Bit 12	Bit 11	Bit 10	Bit 9	Bit 8	Bit 7	Bit 6	Bit 5	Bit 4	Bit 3	Bit 2	Bit 1	Bit 0
Word	Byte																
0	0-1	T 27	T 29	T 45	T 30	Command Mode (T5)				Ctrl Src (T3)		Run (T1)		T 28	T 26	T 25	T 24
1	2-3	Parameter Number Read															
2	4-5	Parameter Value Read															
3	6-7	Parameter Number Written															
4	8-9	Speed Actual (RPM) (T18)															
5	10- 11	Frequency Actual (0.1Hz) (T19)															
6	12- 13	Torque Reference (Current) [Scaling: ± 15bit] (T9)															
7	14- 15	Position Counter [quadrature counts] (T15 Low Word)															
8	16- 17	Position Counter [quadrature counts] (T15 High Word)															
9	18- 19	Positioning Speed Reference (RPM) (T13)															
10	20- 21	Raw Value of A/D Converter for Analog 1 (T71)															
11	22- 23	Raw Value of A/D Converter for Analog 2 (T72)															
12	24- 25	Digital I/O Status Status (T31)															
13	26- 27	Actual Motor Phase Current (100mA) T17)															
14	28- 29	Input Line Voltage ( $V_{RMS}$ ) T21)															
15	30- 31	Fault Status [0=No Fault] (T45) see H Series - Fault Message Description table later in this section.															

- 
- T1 Run Command (0=Stop, 1=FWD, 2=REV, 3=Bipolar)
  - T3 Control Source (0=Keypad, 1=Terminal Strip, 2=Control from network)
  - T5 Command Mode
  - T24 Motor Direction (0=FWD, 1=REV)
  - T25 Zero Speed (0=Not at Zero, 1=At Zero)
  - T26 At Speed (0=Not at Speed, 1=At Speed)
  - T27 Warning (0=No Warning Present, 1=Warning)
  - T28 At Position (0=Not at Position, 1=At Position)
  - T29 At Setpoint (0=Not at Setpoint, 1=At Setpoint)
  - T30 At Set Speed (0=Not at Set Speed, 1=At Set Speed)
  - T45 Fault Status (0=No Fault Condition, 1=Fault Present)

**Table 5-2 Output Data (Profibus to Series H)**

Location		Bit 15	Bit 14	Bit 13	Bit 12	Bit 11	Bit 10	Bit 9	Bit 8	Bit 7	Bit 6	Bit 5	Bit 4	Bit 3	Bit 2	Bit 1	Bit 0
Word	Byte																
0	0-1		T 49	T 46	T 2	Command Mode (T5)			Ctrl Src (T3)		Run (T1)		Digital Outputs (T75)				
1	2-3	Parameter Number To Read															
2	4-5	Parameter Value To Write															
3	6-7	Parameter Number To Write															
4	8-9	Speed Reference (RPM) (T7)															
5	10-11	Hertz Speed Reference (0.1Hz) (T6)															
6	12-13	Torque Reference (Current) [Scaling: ± 15bit] (T9)															
7	14-15	Position Counter [quadrature counts] (T15 Low Word)															
8	16-17	Position Counter [quadrature counts] (T15 High Word)															
9	18-19	Positioning Speed Reference (RPM) (T13)															
10	20-21	Raw Value of A/D Converter for Analog 1 (T73)															
11	22-23	Raw Value of A/D Converter for Analog 2 (T74)															
12	24-25	High Resolution Speed Reference[1/256 RPM] (T8 Low Word)															
13	26-27	High Resolution Speed Reference[1/256 RPM] (T8 High Word)															
14	28-29	Position Reference [Quadrature counts] ( T12 Low Word)															
15	30-31	Position Reference [Quadrature counts] ( T12 High Word)															

T1 Run Command (0=Stop, 1=FWD, 2=REV, 3=Bipolar)

T2 Run Inhibit (1=Set Run Inhibit)

T3 Control Source (0=Keypad, 1=Terminal Strip, 2=Control from network)

T5 Command Mode

T46 Fault Reset (0=No action, 1=Execute fault reset)

T49 Force Fault (0=No action, 0→1=Force Network Fault)

T75 Digital Outputs (Bit0, LSB)=Output #4, Bit 1=Output #3, Bit 2=Output #2, Bit 3=Output #1

Note: For Table 5-2, use Word 5 (T6) for 15H and 21H controls (speed is sent in Hertz), use Word 4 (T7) for 18H, 22H and 23H (speed is sent in RPM).

---

## Command Mode

**Table 5-3 Command Mode Description**

Cmd	Mode	Class	Description
0	None	All	No mode selected. Control is disabled (no voltage or current to motor) regardless of Run CMD.
1	Torque CMD Selected Source	S, V	Closes the current loop. Uses the command input specified by the Level 1, Input block, Command Select parameter.
2	Torque CMD Network	S, V	Closes the current loop. Uses the command input specified by the Torque Reference Register.
3	Speed CMD Selected Source	All	Closes the velocity loop. Uses the command input specified by the Level 1, Input block, Command Select parameter.
4	Speed CMD Network	All	Closes the velocity loop. Uses the command input specified by Speed Reference Register.
5	Orient	S, V *	Homing. The motor is commanded to move in the forward direction at the homing speed until the index pulse is detected and continues for the home offset value. The motor will then hold this home position.
6	Position CMD ABS	S, V *	Closes the position loop with an absolute position command from the Position Reference Register.
7	Position CMD INC	S, V *	Closes the position loop with an incremental position command from the Position Reference Register.
9	Position CMD External	S, V *	Closes the position loop with a command input from an external source (such as EXB005 MPR/PF board).
11	Process Torque	All	Closes the torque process control loop. Uses the specified command input.
12	Process Velocity	All	Closes the velocity process control loop. Uses the specified command input.
13	Auto Tune	E, S, V	Initiates autotune.

### Class

The class field indicates the product classes that support the transaction. The product codes are as follows:

- E = Encoderless Vector
- I = Inverter
- S = Servo
- V = Vector
- \* = with custom software for positioning

---

**Table 5-4 Terminal Strip Table**

Bit	Series 18H, 22H and 23H Controls		Series 15H and 21H Controls	
	Name	Terminal Number	Name	Terminal Number
15		Not Used		Not Used
14		Not Used		Not Used
13		Not Used		Not Used
12	Input 1	J1-8	Input 1	J4-8
11	Input 2	J1-9	Input 2	J4-9
10	Input 3	J1-10	Input 3	J4-10
9	Input 4	J1-11	Input 4	J4-11
8	Input 5	J1-12	Input 5	J4-12
7	Input 6	J1-13	Input 6	J4-13
6	Input 7	J1-14	Input 7	J4-14
5	Input 8	J1-15	Input 8	J4-15
4	Input 9	J1-16	Input 9	J4-16
3	Output 1	J1-19	Output 1	J4-19
2	Output 2	J1-20	Output 2	J4-20
1	Output 3	J1-21	Output 3	J4-21
0	Output 4	J1-22	Output 4	J4-22

---

## Reading Drive Parameters

To read a parameter from the Series H control, set the “Parameter Number to Read” in the output data and the “Parameter Value Read” will be loaded and sent in the input data. When the “Parameter Number Read” in the input data contains the correct parameter number, the “Parameter Value Read” is valid and has the corresponding parameter value from the control. The Profibus card will, always update the “Parameter Number Read” and the “Parameter Value Read” at the exact same time so they will never be out of sync in the input data. If the Profibus card is unable to obtain the value from the drive, it will send 0FFFFh in the Parameter Number Read field in the input data. If a value of 0 is sent in the “Parameter Number to Read” in the output data, then the Profibus card will simply echo this value of 0 back as the “Parameter Number Read” in the input data without actually reading any values from the drive.

The following steps are recommended to ensure proper synchronization between the Profibus host and the Profibus card when reading a parameter from the drive:

- 1) Set the “Parameter Number to Read” to 0 in the output data.
- 2) Wait for 0 to be echoed back as the “Parameter Number Read” in the input data.
- 3) Set the “Parameter Number to Read” to the desired parameter number in the output data.
- 4) Wait until the “Parameter Number Read” in the input data contains either the desired parameter number or a value of 0FFFFh if an error is encountered.

Note: Once set in the output data, as long as the “Parameter Number to Read” remains the same, the Profibus card will continue to read and update the “Parameter Value Read” in the input data.

---

## Writing Drive Parameters

To write a parameter to the drive, set the “Parameter Value to Write” and “Parameter Number to Write” in the output data and the value will be written to the drive. When the write is complete, the “Parameter Number Written” in the input data will contain the correct parameter number (or 0FFFFh if an error occurred writing the parameter to the drive). If a value of 0 is sent in the “Parameter Number to Write” in the output data, then the Profibus card will simply echo this value of 0 back as the “Parameter Number Written” in the input data without actually writing anything to the drive. The following steps are recommended to ensure proper synchronization between the Profibus host and the Profibus card when writing a parameter to the drive:

- 1 ) Set the “Parameter Number to Write” to 0 in the output data.
- 2) Set the “Parameter Value to Write” to the desired value in the output data.
- 3) Set the “Parameter Number to Write” to the desired parameter number.
- 4) Wait until the “Parameter Number Written” in the input data contains either the desired parameter number or a value of 0FFFFh if an error occurred writing the desired parameter.

**Note:** The Profibus card will only write the requested value to the drive one time after it sees a change in the “Parameter Number to Write” or “Parameter Value to Write”, even if these values are continually sent in the output data.

## H Series – Fault Message Description

Fault Message	Fault Code		Fault Description
	15H	18H	
Line Regen	1	1	Fault in Line REGEN converter unit - Series 21H Line REGEN Inverter control.
Feedback Fault		2	Loss of encoder feedback.
Invalid Base ID	3	3	Failed to read configuration from the Power Base ID value in software.
Low INIT Bus V	4	4	Low bus voltage detected on start-up.
Regen Res Power	5	5	Excessive power dissipation required by Dynamic Brake Hardware.
Current SENS FLT	6	6	Failure to sense phase current.
HW Desaturation	7	7	High output current condition detected (greater than 400% of rated output current).
HW Ground Fault	8	8	Ground Fault detected (output current leakage to ground).
Resolver Fault		9	Loss of resolver feedback.
HW Power Supply	10	10	Control Board power supply failure detected.
Overcurrent	11	11	Continuous current limit exceeded.
Bus Overvoltage	12	12	High DC Bus voltage.
Following ERR		13	Motor speed/position does not follow command.
Torque Prove		14	Unbalanced current between all 3 phases.
Bus Undervoltage	15	15	Low DC Bus voltage condition detected.
3 Sec Overload	16	16	Peak output current exceeded the 3 second rating value.
Over Speed		17	Motor RPM exceeded 110% of MAX Speed.
Motor Temp		18	Motor over temperature
Heatsink Temp	19	19	Control heatsink exceeded temperature limit.
External Trip	18	20	Connection at J1/J4 pin 16 and 17 is open.
Param Checksum	51	21	Parameter checksum error.

## H Series – Fault Message Description Continued

Fault Message	Fault Code		Fault Description
	15H	18H	
µp Reset	22	22	A software watchdog timer has reset the processor because a process has timed out.
ROM Fault		23	ROM checksum error.
1 Min Overload	24	24	Peak output current exceeded the 1 minute rating value.
No I Feedback		25	Loss of current feedback
New Base ID	26	26	Control board detected a change in the Power Base ID value in software.
EXB Selection	27	27	Expansion board not installed to support the Level 1 Input Block, Command Select parameter.
Power module		28	Power module failure.
Co-processor		29	Co-processor error (i.e. DSP board).
Software Version		30	Wrong control software version detected.
Feedback Module		31	Feedback HW module failure.
Serial watchdog		32	Serial port transmit/receive error
FLT Network	33	33	Lost network communications.
Hardware Protect	54		A general hardware fault was detected but cannot be isolated.
Unknown FLT Code	55	34	Microprocessor detected a fault that is not identified in the fault code table.
Bus Current SENS	56		Failure to sense bus current.

Note These faults may be different for custom software.

Column labeled 15H means inverter controls (15H, 21H).

Column labeled 18H means vector controls (18H, 22H, 23H).

**BALDOR®**

**BALDOR ELECTRIC COMPANY  
P.O. Box 2400  
Fort Smith, AR 72902-2400  
(479) 646-4711  
Fax (479) 648-5792**

© Baldor Electric Company  
MN1323

Printed in USA  
8/03 C&J500