



**High Resolution  
Analog Input / Output  
Expansion Board**

Catalog No. EXB007A02

Catalog No. EXB007A01

**Installation and Operating Manual**

12/97

MN1316

# Table of Contents

---

## Section 1

<b>General Information</b> .....	1-1
Introduction .....	1-1
Limited Warranty .....	1-2
Safety Notice .....	1-3
Precautions .....	1-3

## Section 2

<b>General Information</b> .....	2-1
Introduction .....	2-1

## Section 3

<b>Installation</b> .....	3-1
Board Installation .....	3-1
1-15HP Size A and B Controls .....	3-2
Single Expansion Board Installation .....	3-2
Dual Expansion Board Installation .....	3-4
15HP Size C and Larger AC Controls .....	3-6
Single Expansion Board Installation .....	3-6
Dual Expansion Board Installation .....	3-8
SCR DC Controls .....	3-10
Single Expansion Board Installation .....	3-10
Dual Expansion Board Installation .....	3-11

## Section 4

<b>Hardware Setup</b> .....	4-1
Jumper Definitions .....	4-2



# Section 1

## General Information

---

### Introduction

The Baldor controls represent the latest technology in microprocessor based motor controls. In addition to the user programmable parameters available in every control, many different expansion boards are available from Baldor to further customize the control to most any application.

Expansion boards are categorized by compatibility into two groups: Group 1 and Group 2, see Table 1-1. A board from either group may be used alone in a control. If two boards are to be used, one board must be from Group 1 and the other from Group 2.

Note: Using two Group 1 or two Group 2 boards in the same control is not allowed.

**Table 1-1 Group 1 and Group 2 Board Categories**

<b>Group 1 Board Name</b>	<b>Catalog No.</b>	<b>Baldor Manual No.</b>
Isolated Input Expansion Board	EXB003A01	MN1314
Master Pulse Reference/ Isolated Pulse Follower	EXB005A01	MN1312
DC Tachometer Interface	EXB006A01	MN1311
Isolated Encoder Expansion Board	EXB008A01	MN1317
Resolver to Digital Interface	EXB009A01	MN1313
<b>Group 2 Board Name</b>		
RS-232 Serial Communication	EXB001A01	MN1310
RS-422/RS-485 High Speed Serial Communication	EXB002A01	MN1310
Four Output Relays/3-15 PSI Pneumatic Expansion Board	EXB004A01	MN1315
High Resolution Analog I/O Expansion Board	EXB007A01	MN1316
2 Isolated Analog Output/ 3 Relay Output Expansion Board	EXB010A01	MN1319

---

## **Limited Warranty**

For a period of two (2) years from the date of original purchase, BALDOR will repair or replace without charge controls and accessories which our examination proves to be defective in material or workmanship. This warranty is valid if the unit has not been tampered with by unauthorized persons, misused, abused, or improperly installed and has been used in accordance with the instructions and/or ratings supplied. This warranty is in lieu of any other warranty or guarantee expressed or implied. BALDOR shall not be held responsible for any expense (including installation and removal), inconvenience, or consequential damage, including injury to any person or property caused by items of our manufacture or sale. (Some states do not allow exclusion or limitation of incidental or consequential damages, so the above exclusion may not apply.) In any event, BALDOR's total liability, under all circumstances, shall not exceed the full purchase price of the control. Claims for purchase price refunds, repairs, or replacements must be referred to BALDOR with all pertinent data as to the defect, the date purchased, the task performed by the control, and the problem encountered. No liability is assumed for expendable items such as fuses.

Goods may be returned only with written notification including a BALDOR Return Authorization Number and any return shipments must be prepaid.

---

## **Safety Notice**

This equipment contains voltages that may be as great as 1000 volts! Electrical shock can cause serious or fatal injury. Only qualified personnel should attempt the start-up procedure or troubleshoot this equipment.

This equipment may be connected to other machines that have rotating parts or parts that are driven by this equipment. Improper use can cause serious or fatal injury. Only qualified personnel should attempt the start-up procedure or troubleshoot this equipment.

### PRECAUTIONS

 **WARNING:** Do not touch any circuit board, power device or electrical connection before you first ensure that power has been disconnected and there is no high voltage present from this equipment or other equipment to which it is connected. Electrical shock can cause serious or fatal injury. Only qualified personnel should attempt the start-up procedure or troubleshoot this equipment.

 **WARNING:** Be sure that you are completely familiar with the safe operation of this equipment. This equipment may be connected to other machines that have rotating parts or parts that are controlled by this equipment. Improper use can cause serious or fatal injury. Only qualified personnel should attempt the start-up procedure or troubleshoot this equipment.

- 
- ⚠ WARNING:** Be sure the system is properly grounded before applying power. Do not apply AC power before you ensure that all grounding instructions have been followed. Electrical shock can cause serious or fatal injury.
- ⚠ WARNING:** Do not remove cover for at least five (5) minutes after AC power is disconnected to allow capacitors to discharge. Dangerous voltages are present inside the equipment. Electrical shock can cause serious or fatal injury.
- ⚠ WARNING:** Improper operation of control may cause violent motion of the motor shaft and driven equipment. Be certain that unexpected motor shaft movement will not cause injury to personnel or damage to equipment. Peak torque of several times the rated motor torque can occur during control failure.
- ⚠ WARNING:** Motor circuit may have high voltage present whenever AC power is applied, even when motor is not rotating. Electrical shock can cause serious or fatal injury.
- ⚠ Caution:** To prevent equipment damage, be certain that the electrical service is not capable of delivering more than the maximum line short circuit current amperes listed in the appropriate control manual, 230 VAC, 460 VAC or 575 VAC maximum per control rating.

## Section 2

### Expansion Board Description

---

#### Introduction

High Resolution Analog Input/Output Expansion Board  
Catalog No. EXB007A01 and EXB007A02.

Features:

Mounting Group 2

One (1) Analog Input

Two (2) Analog Outputs\*

16 Bit\*\* Digital Resolution Maximum

\*Note: These outputs are high resolution. The standard outputs from the control board are disabled.

\*\* Note: Resolution is a minimum of 12 bits during the initial 110 second warm up period. After 110 seconds, the full 16 bit maximum resolution applies.

The Analog I/O expansion board provides one high resolution analog input to the motor control board and two high resolution outputs from the motor control board. Both outputs are configured by jumper selection for 0–10VDC,  $\pm 10$ VDC or 4–20 mA.

Each analog output may be configured to a different voltage or current range, independent of the other output.

Table 2-1 identifies the characteristics of the High Resolution Analog Input/Output Expansion Board.

Table 2–2 specifies the signal resolutions for each type of input and output signal.

Figure 2-1 and 2-2 identify the internal configuration and external connections for the analog input and output signals.

---

**Table 2-1 Characteristics**

High Resolution Input	Number of Inputs	One
	Input Signal Levels	0–5VDC, ±5VDC, 0–10VDC, ±10VDC, or 4–20mA
	Maximum Digital Resolution	14 to 16 bits – Depending on Input Signal Type
High Resolution Outputs	Number of Outputs	Two
	Output Signal Levels	0–10VDC, ±10VDC, or 4–20mA
	Maximum Digital Resolution	15 to 16 bits – Depending on Output Signal Type

**Table 2-2 Signal Resolution**

Input Signal	Signal Type	Digital Resolution	Analog Resolution
<b>High Resolution Input</b>			
±10VDC	Voltage	16 Bits (65636 Parts)	305 µVDC (0.000305 VDC)
0-10VDC	Voltage	15 Bits (32768 Parts)	305 µVDC (0.000305 VDC)
±5VDC	Voltage	15 Bits (32768 Parts)	305 µVDC (0.000305 VDC)
0-5VDC	Voltage	14 Bits (16384 Parts)	305 µVDC (0.000305 VDC)
4-20mA	Current	15 Bits (32768 Parts)	0.488 µA (0.000000488 AMP)
<b>High Resolution Output</b>			
±10VDC	Voltage	16 Bits (65636 Parts)	305 µVDC (0.000305 VDC)
0-10VDC	Voltage	15 Bits (32768 Parts)	305 µVDC (0.000305 VDC)
4-20mA	Current	15 Bits (32768 Parts)	0.488 µA (0.000000488 AMP)

Note: Resolution is a minimum of 12 bits during the initial 110 second warm up period. After 110 seconds, the full 16 bit maximum resolution applies.

**Figure 2-1 High Resolution Input Configuration**

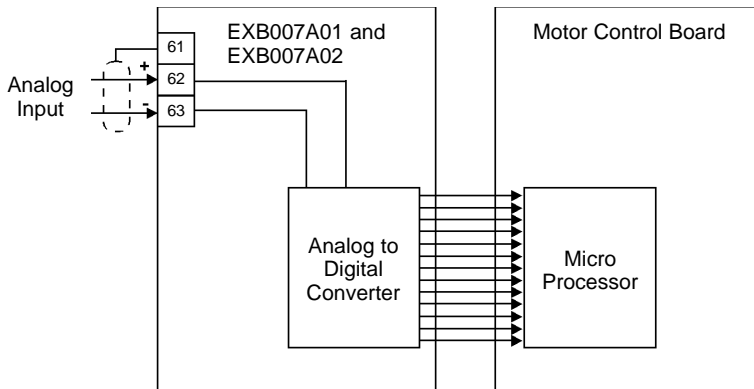

**Figure 2-2 High Resolution Output Configuration**

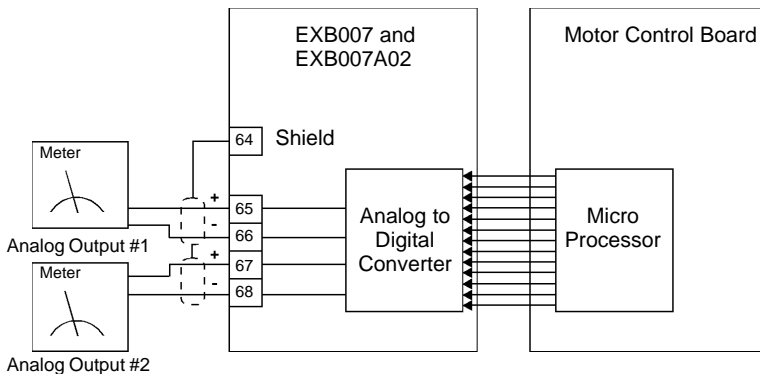

---

## Section 3 Installation

---

### Board Installation

This section describes the Expansion Board installation procedure.

**Caution:**        **Before you proceed, be sure to read and become familiar with the safety precautions at the beginning of this manual. Do not proceed if you are unsure of the safety precautions described. If you have any questions, contact BALDOR before you proceed.**

1. Remove the expansion board from the shipping container.
2. Remove all packing material from the board.

**Caution:**        **Be sure all packing materials are removed from the board. Conductive foam may be present on the connectors to prevent static build up during shipping. This can prevent proper circuit operation.**

Installation differs between the 1-15 HP Size A and B controls and the 15HP Size C and larger AC controls and the SCR DC controls. If you are installing only one board, refer to the "Single Expansion Board Installation" procedure. If you are installing two expansion boards (or a second board) refer to the "Dual Expansion Board Installation" procedure.

---

## **1-15HP Size A and B Controls**

(For all 15H Inverter, 18H Vector, and 23H Servo).

### *Single Expansion Board Installation*

Procedure:

1. Be sure drive operation is terminated and secured.
2. Remove all power sources from the control.
3. Wait at least 5 minutes for internal capacitors to discharge.
4. Remove the four (4) Phillips head screws that secure the control cover.
5. Remove the control cover.
6. Remove the #6 screw at position MH1 (upper left on the main circuit board. See Figure 3-1.
7. Install the long standoffs provided in the installation hardware as shown in Figure 3-1. (Be sure the Male/Female standoff is at position MH1. The other three are Female/Female.)
8. Slide the expansion board male connector into the female connector of the control board.
9. Securely mount the expansion board to the standoffs installed in step 7 using #6 screws provided in the installation hardware. See Figure 3-2.
10. The mechanical installation of the expansion board is now complete. Refer to Section 4 of this manual and configure the jumpers as desired. Also complete the wiring before you proceed to step 11.
11. When complete, install the control cover using the four (4) Phillips head screws.
12. Restore all power sources to the control.
13. Restore drive operation.

**Figure 3-1 Single Expansion Board Installation**

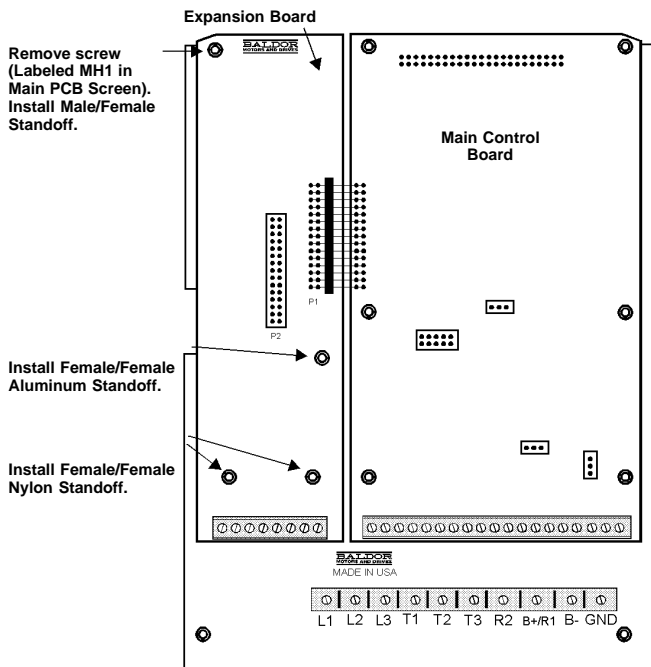

Terminal tightening torque is 7 lb-in (0.8 Nm) maximum.

**Figure 3-2 Single Expansion Board Installation**

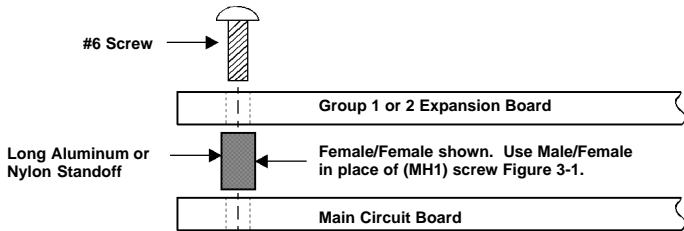

---

## **1-15HP Size A and B Controls** (Continued)

### *Dual Expansion Board Installation*

#### Procedure:

1. Be sure drive operation is terminated and secured.
2. Remove all power sources from the control.
3. Wait at least 5 minutes for internal capacitors to discharge.
4. Remove the four (4) Phillips head screws that secure the control cover.
5. Remove the control cover.
6. Remove the #6 screw at position MH1 (upper left on the main circuit board. See Figure 3-1.
7. Install the long standoffs provided in the installation hardware as shown in Figure 3-1. (Be sure the Male/Female standoff is at position MH1. The other three are Female/Female.)
8. Slide the Group 1 board male connector into the female connector of the control board. See Figure 3-3.
9. Securely mount the Group 1 expansion board to the standoffs installed in step 7 using the 4 short aluminum standoffs provided in the installation hardware. See Figure 3-3.
10. The mechanical installation of the Group 1 expansion board is now complete. Refer to the manual for the Group 1 board and configure the jumpers as desired. Also complete the wiring before you proceed to step 11.
11. Install the Group 2 board on top of the previously installed Group 1 board by plugging the female connector onto the male connector of the Group 1 board as shown in Figure 3-3.
12. Secure this Group 2 board to the Group 1 board using the #6 screws provided.

---

## 1-15HP Size A and B Controls

### Dual Expansion Board Installation (Continued)

- The mechanical installation of the first expansion board is now complete. Refer to the manual for the Group 2 board and configure any jumpers and switches as desired. Also complete the wiring for this board before you install the cover.
- When complete, install the control cover using the four (4) Phillips head screws.
- Restore all power sources to the control.
- Restore drive operation.

**Figure 3-3 Dual Expansion Board Installation**

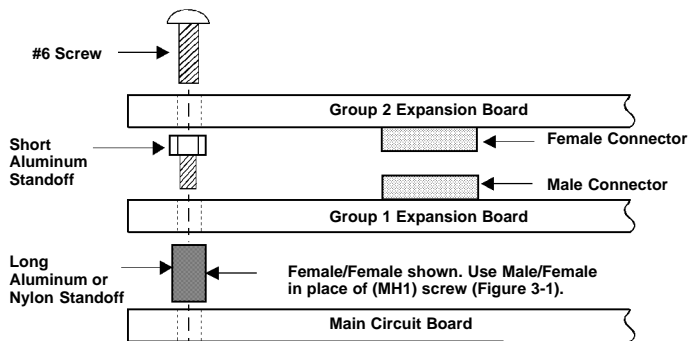

---

## **15HP Size C and Larger AC Controls**

(For all 15H Inverter, 21H Line Regen Inverter, 18H Vector, 22H Line Regen Vector and 23H Servo).

### *Single Expansion Board Installation*

Procedure:

1. Be sure drive operation is terminated and secured.
2. Remove all power sources from the control.
3. Wait at least 5 minutes for internal capacitors to discharge.
4. Remove the four (4) Phillips head screws ( $1/4$  turn) that secure the control cover. (On floor mounted G size enclosures, open the enclosure door).
5. Remove the control cover.
6. Slide the expansion board male connector into the female connector of the control board. See Figure 3-4.
7. Securely mount the expansion board to the sheet metal mounting plate using the #6 screws provided in the installation hardware. See Figure 3-5.
8. The mechanical installation of the expansion board is now complete. Refer to Section 4 of this manual and configure the jumpers as desired. Also complete the wiring before you proceed to step 9.
9. When complete, install the control cover using the four (4) Phillips head screws ( $1/4$  turn). (On floor mounted G size enclosures, close the enclosure door).
10. Restore all power sources to the control.
11. Restore drive operation.

---

## 15HP Size C and Larger AC Controls Single Expansion Board Installation (Continued)

### Figure 3-4 Single Expansion Board Installation

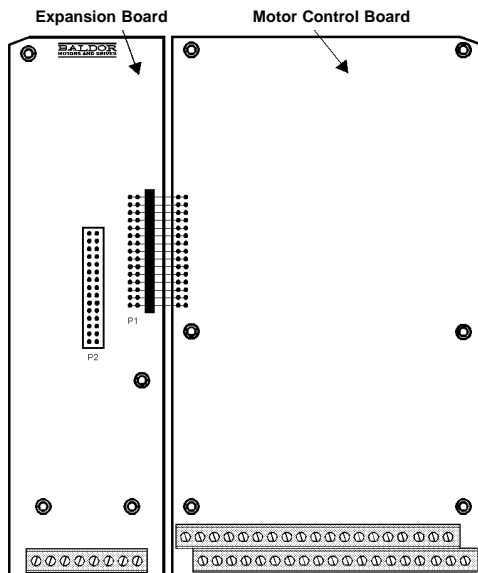

Terminal tightening torque is 7 lb-in (0.8 Nm) maximum.

### Figure 3-5 Single Expansion Board Installation

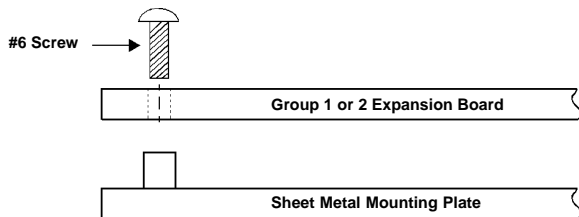

---

## **15HP Size C and Larger AC Controls** (Continued)

### *Dual Expansion Board Installation*

#### Procedure:

1. Be sure drive operation is terminated and secured.
2. Remove all power sources from the control.
3. Wait at least 5 minutes for internal capacitors to discharge.
4. Remove the four (4) Phillips head screws ( $1/4$  turn) that secure the control cover. (On floor mounted G size enclosures, open the enclosure door).
5. Remove the control cover.
6. Slide the Group 1 expansion board male connector into the female connector of the control board. See Figure 3-4.
7. Securely mount the Group 1 expansion board to the sheet metal mounting plate using the short standoffs provided in the installation hardware. See Figure 3-6.
8. The mechanical installation of the expansion board is now complete. Refer to the manual for the Group 1 board and configure the jumpers as desired. Also complete the wiring before you proceed to step 9.
9. Install the Group 2 board on top of the previously installed Group 1 board by plugging the female connector onto the male connector of the Group 1 board as shown in Figure 3-6.
10. Secure this Group 2 board to the Group 1 board using the #6 screws provided. See Figure 3-6.
11. The mechanical installation of the expansion board is now complete. Refer to the manual for the Group 2 board and configure any jumpers and switches as desired. Also complete the wiring for this board before you install the cover.

---

## **15HP Size C and Larger AC Controls**

### *Dual Expansion Board Installation (Continued)*

12. When complete, install the control cover using the four (4) Phillips head screws ( $1/4$  turn). (On floor mounted G size enclosures, close the enclosure door).
13. Restore all power sources to the control.
14. Restore drive operation.

**Figure 3-6 Dual Expansion Board Installation**

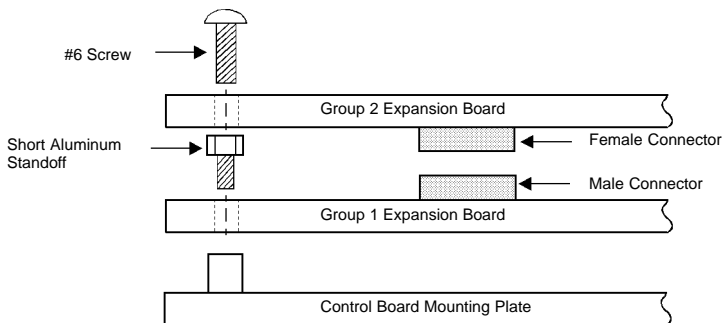

---

## **SCR DC Controls**

(For 19H and 20H SCR DC Controls).

### *Single Expansion Board Installation*

Procedure:

1. Be sure drive operation is terminated and secured.
2. Remove all power sources from the control.
3. Wait at least 5 minutes for internal capacitors to discharge.
4. Slide the expansion board male connector into the female connector of the control board. See Figure 3-4.
5. Securely mount the expansion board to the sheet metal mounting plate using the #6 screws provided in the installation hardware. See Figure 3-5.
6. The mechanical installation of the expansion board is now complete. Refer to the Group 1 manual and configure the jumpers as desired. Also complete the wiring before you proceed to step 7.
7. Restore all power sources to the control.
8. Restore drive operation.

---

## **SCR DC Controls** (Continued)

### *Dual Expansion Board Installation*

#### Procedure:

1. Be sure drive operation is terminated and secured.
2. Remove all power sources from the control.
3. Wait at least 5 minutes for internal capacitors to discharge.
4. Slide the Group 1 board male connector into the female connector of the control board. See Figure 3-4.
5. Securely mount the Group 1 expansion board to the sheet metal mounting plate using the short standoffs provided in the installation hardware. See Figure 3-6.
6. The mechanical installation of the expansion board is now complete. Refer to the Group 1 manual and configure the jumpers as desired. Also complete the wiring before you proceed to step 7.
7. Install the Group 2 board on top of the previously installed Group 1 board by plugging the female connector onto the male connector of the Group 1 board as shown in Figure 3-6.
8. Secure this Group 2 board to the Group 1 board using the #6 screws provided. See Figure 3-6.
9. The mechanical installation of the expansion board is now complete. Refer to the manual for the Group 2 board and configure any jumpers and switches as desired. Also complete the wiring for this board before you proceed to step 10.
10. Restore all power sources to the control.
11. Restore drive operation.



## Section 4

### Hardware Setup

---

High Resolution Analog Input/Output Expansion Board  
Catalog Number: EXB007A01 and EXB007A02.

Features:

- Mounting Group 2
- One (1) Analog Input
- Two (2) Analog Outputs
- 16 Bit Digital Resolution Maximum

The Analog I/O expansion board provides one high resolution analog input to the motor control board and two high resolution outputs from the motor control board. Each output is independent of the other and both may be configured by jumper selection for 0–10VDC,  $\pm 10$ VDC or 4–20 mA.

The high resolution input A/D converter converts a source current or voltage into a digital signal for the motor control.

---

## **Jumper Definitions**

Table 4-1 defines the jumper position settings for jumpers JMP1 to JMP9. Jumper locations on the board are shown in Figure 4-1.

**Table 4-1 Jumper Position Settings**

<b>High Resolution Analog Input</b>		
<b>Function</b>	<b>Jumper Number</b>	<b>Jumper Position</b>
Input Current	JMP 9	I
Input Voltage		V

<b>High Resolution Analog Output #1</b>		
<b>Function</b>	<b>Jumper Number</b>	<b>Jumper Position</b>
Output Current	JMP 1	I
	JMP 2	I
	JMP 3	I
Output Voltage	JMP 1	V
	JMP 2	V
	JMP 3	V
Inverted Signal	JMP 4	$\overline{\text{DA1}}$
Non-Inverted Signal (Direct Acting)	JMP 4	<b>DA1</b>

<b>High Resolution Analog Output #2</b>		
<b>Function</b>	<b>Jumper Number</b>	<b>Jumper Position</b>
Output Current	JMP 5	I
	JMP 6	I
	JMP 7	I
Output Voltage	JMP 5	V
	JMP 6	V
	JMP 7	V
Inverted Signal	JMP 8	$\overline{\text{DA2}}$
Non-Inverted Signal (Direct Acting)	JMP 8	<b>DA2</b>

**Figure 4-1 Jumper and Terminal Locations (Top View)**

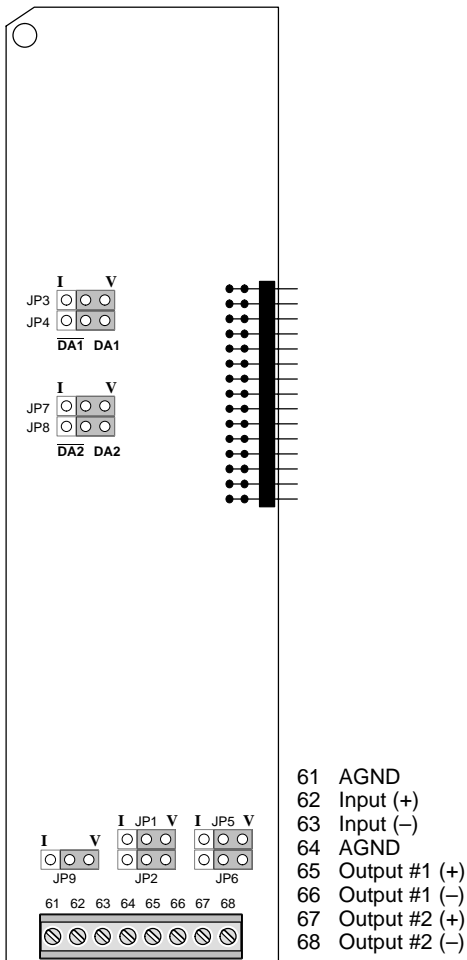

Terminal tightening torque is 7 lb-in (0.8 Nm) maximum.



**BALDOR<sup>®</sup>**  
**MOTORS AND DRIVES**

**BALDOR ELECTRIC COMPANY**

**P.O. Box 2400**

**Fort Smith, AR 72902-2400**

**(501) 646-4711**

**Fax (501) 648-5792**

© Baldor Electric Company  
MN1316

Printed in USA  
12/97 C&J 2500