



**Isolated Input
Expansion Board**

Catalog No. EXB003A02

Catalog No. EXB003A03

Catalog No. EXB003A04

Catalog No. EXB003A05

Installation and Operating Manual

Table of Contents

Section 1	
General Information	1-1
Introduction	1-1
Limited Warranty	1-2
Safety Notice	1-3
Precautions	1-3
Section 2	
Expansion Board Description	2-1
Section 3	
Installation	3-1
Board Installation	3-1
AC Controls	3-2
Single Expansion Board Installation	3-2
Dual Expansion Board Installation	3-4
SCR DC Controls	3-6
Single Expansion Board Installation	3-6
Dual Expansion Board Installation	3-7
Section 4	
Hardware Setup	4-1



Section 1

General Information

Introduction

The Baldor controls represent the latest technology in microprocessor based motor controls. In addition to the user programmable parameters available in every control, many different expansion boards are available from Baldor to further customize the control to most any application.

Expansion boards are categorized by compatibility into two groups: Group 1 and Group 2, see Table 1-1. A board from either group may be used alone in a control. If two boards are to be used, one board must be from Group 1 and the other from Group 2.

Note: Using two Group 1 or two Group 2 boards in the same control is not allowed.

Table 1-1 Group 1 and Group 2 Board Categories

Group 1 Board Name	Catalog No.	Manual No.
Isolated Input	EXB003A0X	MN1314
Master Pulse Reference/ Isolated Pulse Follower	EXB005A0X	MN1312
DC Tachometer Interface	EXB006A0X	MN1311
Isolated Encoder	EXB008A0X	MN1317
Resolver to Digital Interface	EXB009A0X	MN1313
Group 2 Board Name		
RS-232 Serial	EXB001A0X	MN1310
RS-422/RS-485 Serial	EXB002A0X	MN1310
RS-232/485 Serial	EXB012A0X	MN1310
Four Output Relays/3-15 PSI Pneumatic	EXB004A0X	MN1315
High Resolution Analog I/O	EXB007A0X	MN1316
2 Isolated Analog Output/ 3 Relay Output	EXB010A0X	MN1319
Device Net	EXB013A0X	MN1320
Modbus Plus	EXB015A0X	MN1322
Profibus DP	EXB014A0X	MN1323

Limited Warranty

For a period of two (2) years from the date of original purchase, BALDOR will repair or replace without charge controls and accessories which our examination proves to be defective in material or workmanship. This warranty is valid if the unit has not been tampered with by unauthorized persons, misused, abused, or improperly installed and has been used in accordance with the instructions and/or ratings supplied. This warranty is in lieu of any other warranty or guarantee expressed or implied. BALDOR shall not be held responsible for any expense (including installation and removal), inconvenience, or consequential damage, including injury to any person or property caused by items of our manufacture or sale. (Some states do not allow exclusion or limitation of incidental or consequential damages, so the above exclusion may not apply.) In any event, BALDOR's total liability, under all circumstances, shall not exceed the full purchase price of the control. Claims for purchase price refunds, repairs, or replacements must be referred to BALDOR with all pertinent data as to the defect, the date purchased, the task performed by the control, and the problem encountered. No liability is assumed for expendable items such as fuses.



Goods may be returned only with written notification including a BALDOR Return Authorization Number and any return shipments must be prepaid.

Safety Notice

This equipment contains voltages that may be as great as 1000 volts! Electrical shock can cause serious or fatal injury. Only qualified personnel should attempt the start-up procedure or troubleshoot this equipment.

This equipment may be connected to other machines that have rotating parts or parts that are driven by this equipment. Improper use can cause serious or fatal injury. Only qualified personnel should attempt the start-up procedure or troubleshoot this equipment.

PRECAUTIONS

-  **WARNING:** Do not touch any circuit board, power device or electrical connection before you first ensure that power has been disconnected and there is no high voltage present from this equipment or other equipment to which it is connected. Electrical shock can cause serious or fatal injury. Only qualified personnel should attempt the start-up procedure or troubleshoot this equipment.
-  **WARNING:** Be sure that you are completely familiar with the safe operation of this equipment. This equipment may be connected to other machines that have rotating parts or parts that are controlled by this equipment. Improper use can cause serious or fatal injury. Only qualified personnel should attempt the start-up procedure or troubleshoot this equipment.

-
- ⚠ WARNING:** Be sure the system is properly grounded before applying power. Do not apply AC power before you ensure that all grounding instructions have been followed. Electrical shock can cause serious or fatal injury.
- ⚠ WARNING:** Do not remove cover for at least five (5) minutes after AC power is disconnected to allow capacitors to discharge. Dangerous voltages are present inside the equipment. Electrical shock can cause serious or fatal injury.
- ⚠ WARNING:** Improper operation of control may cause violent motion of the motor shaft and driven equipment. Be certain that unexpected motor shaft movement will not cause injury to personnel or damage to equipment. Peak torque of several times the rated motor torque can occur during control failure.
- ⚠ WARNING:** Motor circuit may have high voltage present whenever AC power is applied, even when motor is not rotating. Electrical shock can cause serious or fatal injury.
- ⚠ Caution:** To prevent equipment damage, be certain that the electrical service is not capable of delivering more than the maximum line short circuit current amperes listed in the appropriate control manual, 230 VAC, 460 VAC or 575 VAC maximum per control rating.

Section 2

Expansion Board Description

Isolated Input Expansion Board

Catalog No. EXB003A02

Catalog No. EXB003A03

Catalog No. EXB003A04 – Not compatible with 19H and 20H.

Catalog No. EXB003A05 – Not compatible with 19H and 20H.

Features:

Mounting Group 1

Optically Isolated Inputs

Table 2-1 defines the specifications of the Isolated Input Expansion Board.

Table 2-1 Specifications

Catalog No.	No. of Inputs	Input Voltage	Input Freq.	Input Impedance
EXB003A02	8	10–30 VDC	N.A.	10 K Ω
EXB003A03	8	70–130 VAC	48 - 62 Hz	10 K Ω
EXB003A04	9	10–30 VDC	N.A.	10 K Ω
EXB003A05	9	70–130 VAC	48 - 62 Hz	10 K Ω

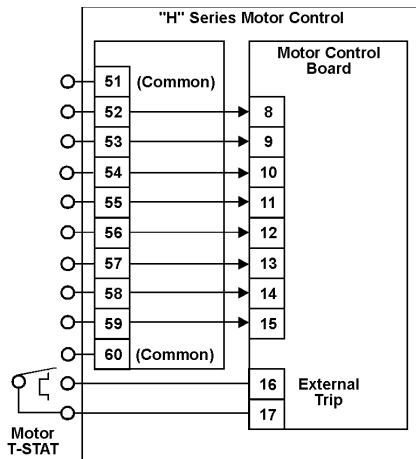
The Isolated Input Expansion Board converts high level AC or DC input voltage levels to the proper range for the Motor Control Board. The inputs are used to command the ON and OFF states of the digital command inputs of the Motor Control Board.

The isolated inputs terminals automatically perform the programmed function of the respective Motor Control Board inputs. See Figures 2-1 and 2-2. This means that when the Isolated Input Expansion Board is installed, external connections to those Motor Control Board terminals is not allowed.

Figure 2-1 Expansion Board/Motor Control Board Relation

EXB003A02
EXB003A03

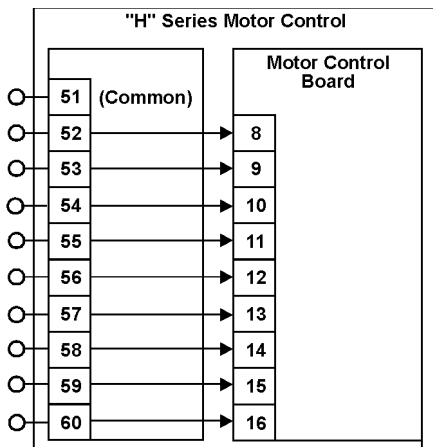
The external trip (Motor T-Stat) on terminals 16 & 17 of the motor control board is still available with the expansion board installed.



Terminal tightening torque is 7 lb-in (0.8 Nm) maximum.

Figure 2-2 Expansion Board/Motor Control Board Relation

EXB003A04
EXB003A05




Terminal tightening torque is 7 lb-in (0.8 Nm) maximum.

Section 3


Installation

Board Installation

This section describes the Expansion Board installation procedure.

 **Caution:** Before you proceed, be sure to read and become familiar with the safety precautions at the beginning of this manual. Do not proceed if you are unsure of the safety precautions described. If you have any questions, contact BALDOR before you proceed.

1. Remove the expansion board from the shipping container.
2. Remove all packing material from the board.

 **Caution:** Be sure all packing materials are removed from the board. Conductive foam may be present on the connectors to prevent static build up during shipping. This can prevent proper circuit operation.

If you are installing only one board, refer to the “Single Expansion Board Installation” procedure. If you are installing two expansion boards (or a second board) refer to the “Dual Expansion Board Installation” procedure.

AC Controls

(For all 15H Inverter, 21H Line Regen Inverter, 18H Vector, 22H Line Regen Vector and 23H Servo).

Single Expansion Board Installation

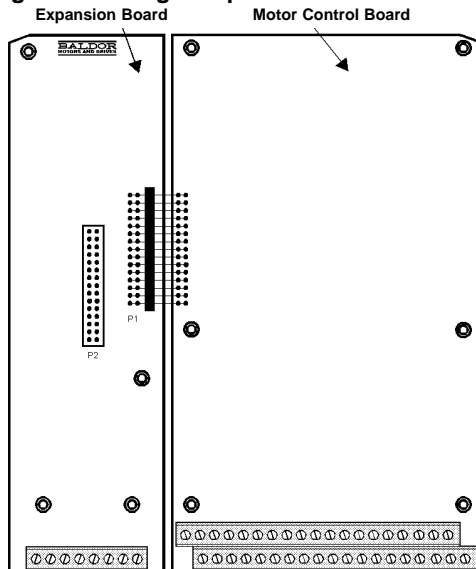
Procedure:

1. Be sure drive operation is terminated and secured.
2. Remove all power sources from the control.
3. Wait at least 5 minutes for internal capacitors to discharge.
4. Remove the four (4) Phillips head screws ($1/4$ turn) that secure the control cover. (For A & B size, remove four screws that secure the cover. On floor mounted G size enclosures, open the enclosure door).
5. Remove the control cover.
6. Slide the expansion board male connector into the female connector of the control board. See Figure 3-1.
7. Securely mount the expansion board to the sheet metal mounting plate using the #6 screws provided in the installation hardware. See Figure 3-2.
8. The mechanical installation of the expansion board is now complete. Refer to Section 4 of this manual and configure the jumpers as desired. Also complete the wiring before you proceed to step 9.
9. When complete, install the control cover using the four (4) Phillips head screws ($1/4$ turn). (For A & B size, install four screws that secure the cover. On floor mounted G size enclosures, close the enclosure door).
10. Restore all power sources to the control.
11. Restore drive operation.

AC Controls

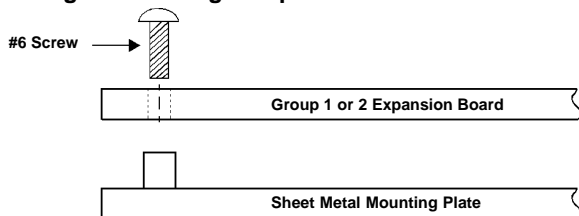
Single Expansion Board Installation (Continued)

Figure 3-1 Single Expansion Board Installation



Terminal tightening torque is 7 lb-in (0.8 Nm) maximum.

Figure 3-2 Single Expansion Board Installation



AC Controls (Continued)

Dual Expansion Board Installation

Procedure:

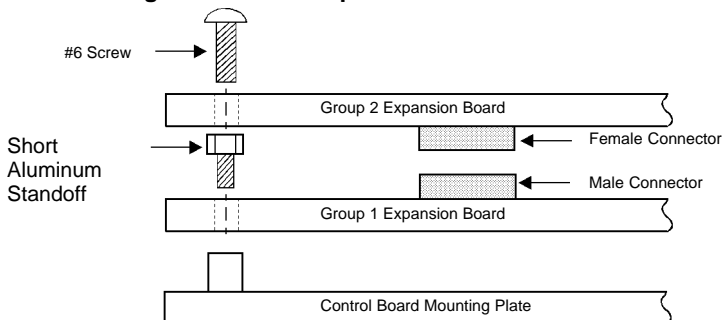
1. Be sure drive operation is terminated and secured.
2. Remove all power sources from the control.
3. Wait at least 5 minutes for internal capacitors to discharge.
4. Remove the four (4) Phillips head screws ($\frac{1}{4}$ turn) that secure the control cover. (For A & B size, remove four screws that secure the cover. On floor mounted G size enclosures, open the enclosure door).
5. Remove the control cover.
6. Slide the Group 1 expansion board male connector into the female connector of the control board. See Figure 3-1.
7. Securely mount the Group 1 expansion board to the sheet metal mounting plate using the short standoffs provided in the installation hardware. See Figure 3-3.
8. The mechanical installation of the expansion board is now complete. Refer to the manual for the Group 1 board and configure the jumpers as desired. Also complete the wiring before you proceed to step 9.
9. Install the Group 2 board on top of the previously installed Group 1 board by plugging the female connector onto the male connector of the Group 1 board as shown in Figure 3-3.
10. Secure this Group 2 board to the Group 1 board using the #6 screws provided. See Figure 3-3.
11. The mechanical installation of the expansion board is now complete. Refer to the manual for the Group 2 board and configure any jumpers and switches as desired. Also complete the wiring for this board before you install or close the cover.

AC Controls

Dual Expansion Board Installation (Continued)

- When complete, install the control cover using the four (4) Phillips head screws ($\frac{1}{4}$ turn). (For A & B size, install four screws that secure the cover. On floor mounted G size enclosures, close the enclosure door).
- Restore all power sources to the control.
- Restore drive operation.

Figure 3-3 Dual Expansion Board Installation



SCR DC Controls

(For 19H and 20H SCR DC Controls).

Single Expansion Board Installation

Procedure:

1. Be sure drive operation is terminated and secured.
2. Remove all power sources from the control.
3. Wait at least 5 minutes for internal capacitors to discharge.
4. Slide the expansion board male connector into the female connector of the control board. See Figure 3-1.
5. Securely mount the expansion board to the sheet metal mounting plate using the #6 screws provided in the installation hardware. See Figure 3-2.
6. The mechanical installation of the expansion board is now complete. Refer to the Group 1 manual and configure the jumpers as desired. Also complete the wiring before you proceed to step 7.
7. Restore all power sources to the control.
8. Restore drive operation.

SCR DC Controls (Continued)

Dual Expansion Board Installation

Procedure:

1. Be sure drive operation is terminated and secured.
2. Remove all power sources from the control.
3. Wait at least 5 minutes for internal capacitors to discharge.
4. Slide the Group 1 board male connector into the female connector of the control board. See Figure 3-1.
5. Securely mount the Group 1 expansion board to the sheet metal mounting plate using the short standoffs provided in the installation hardware. See Figure 3-3.
6. The mechanical installation of the expansion board is now complete. Refer to the Group 1 manual and configure the jumpers as desired. Also complete the wiring before you proceed to step 7.
7. Install the Group 2 board on top of the previously installed Group 1 board by plugging the female connector onto the male connector of the Group 1 board as shown in Figure 3-3.
8. Secure this Group 2 board to the Group 1 board using the #6 screws provided. See Figure 3-3.
9. The mechanical installation of the expansion board is now complete. Refer to the manual for the Group 2 board and configure any jumpers and switches as desired. Also complete the wiring for this board before you proceed to step 10.
10. Restore all power sources to the control.
11. Restore drive operation.



Section 4 Hardware Setup

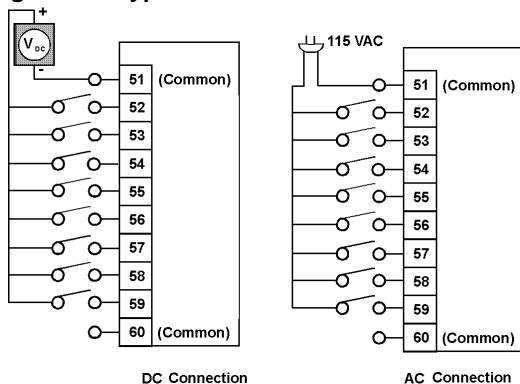
Isolated Input Expansion Board

Figures 4-1 and 4-2 illustrates the external connections for DC or AC voltage operation. No jumpers are required on this board.

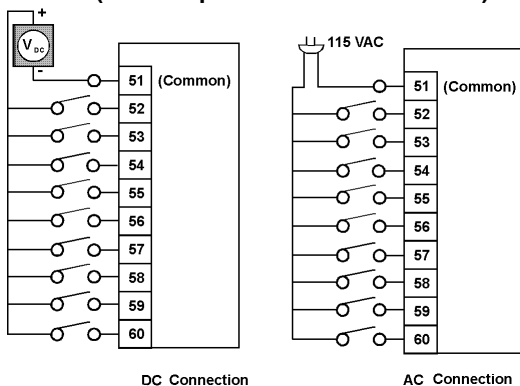
Figure 4-3 illustrates the physical location of the terminals on the expansion board.

Note: The diagnostic screens (Digital I/O) can be used to verify proper operation of the inputs. Refer to the motor control manual.

Figure 4-1 Typical Connections EXB003A02 and A03

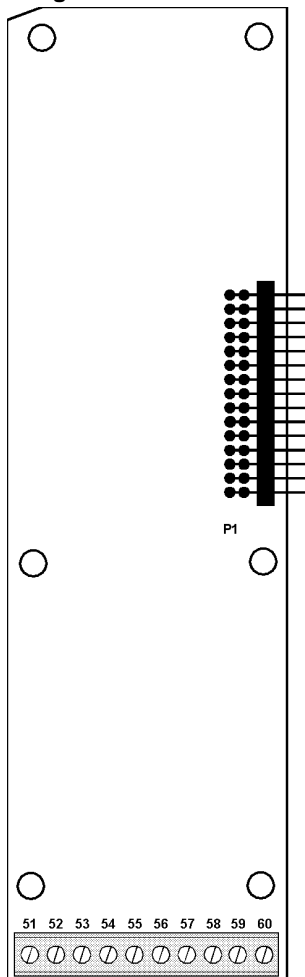


**Figure 4-2 Typical Connections EXB003A04 and A05
(Not compatible with 19H and 20H)**



Terminal tightening torque is 7 lb-in (0.8 Nm) maximum.

Figure 4-3 Terminal Locations



Terminal tightening torque is 7 lb-in (0.8 Nm) maximum.

BALDOR[®]
MOTORS AND DRIVES

BALDOR ELECTRIC COMPANY
P.O. Box 2400
Fort Smith, AR 72902-2400
(501) 646-4711
Fax (501) 648-5792

© Baldor Electric Company
MN1314

Printed in USA
4/99 C&J2500