

Standby or Prime Power Features

- Heavy-duty industrial diesel engine
- Brushless synchronous alternators: four-pole construction, dynamically balanced
- Full featured microprocessor based controller: fully programmable for maximum flexibility
- Prototype tested and production tested
- Gen-set accepts rated load in one step
- UL2200 available – consult factory
- Optional weather-proof and sound attenuated enclosures available
- Full range of accessories and options available
- Heavy-duty construction for use in prime or standby application
- Manufactured in an ISO-9001 certified facility
- Backed by a world wide network of parts and service center

Gen Set Ratings

Baldor Genset Model	kW Rating Standby	kW Rating Prime	Voltage Hi-Wye	Voltage Low-Wye	Voltage Delta	Number of Leads	Phase	Hz	Power Factor
IDLC400-VA	400	360	480/277	240/139	N/A	12	3	60	0.8
IDLC400-VA	400	360	440/254	220/127	N/A	12	3	60	0.8
IDLC400-VA	400	360	416/240	208/120	240/120	12	3	60	0.8
IDLC400-VB	400	360	380/220	N/A	N/A	12	3	60	0.8
IDLC400-VH	400	360	600/347	N/A	N/A	12	3	60	0.8
Consult Baldor			380/220	N/A	N/A	12	3	50	0.8

NOTES: For ratings and voltages not listed above refer to the Gen-Set Selector or consult factory
 Standby ratings do not have an overload capability but can be used for the duration of the utility failure per ISO-3046, DIN6271 and BS5514
 Prime (Unlimited Running Time) ratings are continuous per DIN 6271 and ISO-3046 with 10% overload capacity
 Base Load (Continuous) ratings are continuous per DIN 6271, BS5514 and ISO-8528 with no sustained overload capacity
 Consult factory for Base Load ratings
 Altitude derate is 4% for each 1000 feet over 5000
 Temperature derate is 1% for 10°F over 100°F ambient
 Fuel consumption will vary, values are estimates

Controls Digital Control Module

DCM Features

- Large Backlit LCD
- Microprocessor Based Design
- Displays Eight Engine/Generator Parameters Simultaneously
- Individual Parameters Through Scroll Down Menu
- Front Panel Programmable
- Monitors Six Engine Parameters
- Monitors 3-Phase and 1-Phase Voltage and Current
- Displays KW, KVA, KVAR, Kilowatt Hours and Power Factor
- Programmable Digital Inputs
- Programmable Digital Outputs
- Fault Logging for Last Five Faults
- Resettable Kilowatt Hour Meter

Engine Monitoring Channels

- Battery Voltage (9-36VDC)
- Oil Temperature (100-300 Deg.)
- Coolant Temperature (60-300 Deg.)
- Oil Pressure (1-150 PSI)
- Fuel Level (0-100 Percent)
- Engine RPM (0-4000)

Designed To Meet/Exceed the Standards Below:

- UL 508
- UL 2200
- NFPA 70
- NFPA 110

Engine Technical Data

Manufacturer	Volvo
Engine Model	TAD1242GEP
Engine Type	4 cycle, 6 cylinders
Aspiration	Turbocharged and Water-to-Air Intercooled
No. of Cylinders & Configuration	In-line
Displacement - cu. in. (liters)	740.2 (12.13)
Bore and Stroke - in. (mm)	5.16 x 5.91 (131 x 150)
Compression Ratio	17.5:1
Air Filter Type	Dry
Governor Type	Electronic
Governor Make	EDCIII
Injection Pump Type/Model	Bosch
Frequency Regulation, steady state	+/- 0.5%
Frequency Regulation, no load to full load	Isochronous
Battery Voltage	24 V
Water Pump Type	Centrifugal
Coolant Cap. - radiator cooled - qts - liters	6.34 24
Coolant Capacity - engine only - gals - liters	5.28 20
Oil Pan Capacity - gals - liters	9.2
Rec'd Oil Type - SF/CC/CD-10°F to 90°F	10W-40

Engine Operational Values	English 50 Hz	Metric 50 Hz	English 60 Hz	Metric 60 Hz
Maximum ambient temperature - F° - C°	N/A	N/A	104/122	40/50
Heat rejected to coolant - Btu/min - kWm	8019	141	9838	173
Max. power at rated rpm - bhp - kWm	526	387	585	430.00
Coolant flow - gpm - lpm	76.2	4.8	95.4	6
Exhaust temperature - F° - C°	977	525	1049	565
Exhaust flow - cfm - m ³ /min	2419	1142	3002	1417
Normal oil press. range idle/run - PSI - kgf/cm ²	36.5/58-80	250/400-550	36.5/58-80	250/400-550
Max fuel flow to injection pump - gph - Lph	132	500	145	550

Gen Set Technical Data

Alternator Technical Data

Generator Frame	544	Voltage Regulation NL - FL	+/- 1.0%
Exciter	Brushless	Underspeed Protection	Standard
Cooling Fan	Cast alloy aluminum	Overexcitation Protection	Optional
Bearing	Single, double shielded	Overvoltage Protection	Optional
Connection Type	Reconnectable	Loss of Sensing Protection	Standard
Insulation Type	Class H	Overspeed	2250 RPM
Windings	100% copper	Standards	NEMA, IEC, IEEE, CSA, BS
Pitch	2/3	Phase Sequence	A(U),B(V),C(W)
Amortisseur Winding	Full	TIF (1960 Weightings)	<50
Voltage Regulator	SX440	Excitation System	PMG - Optional

Alternator Performance Data

	Model IDLC400-VA	Model IDLC400-VB	Model IDLC400-VH
Temperature rise by resistance - °C (Stand-By)	125/40	125/40	125/40
Generator model number	HC544C	HC544D	HC544C
Generator kW at 125/105/80°C over 40°C ambient (480 Volt , 60Hz)	475/430/376	515/470/412	475/430/376
SkVA output with 30% voltage dip max. 100% recovery at 60 Hz	1200	1300	1200
Maximum skva at 90% sustained voltage dip	Consult Factory	Consult Factory	Consult Factory
Subtransient reactance at voltage listed	11.00%	10.00%	11.00%
Line - line harmonic maximum total	5.00%	5.00%	5.00%

Installation/Application Data

	English 50 Hz	Metric 50 Hz	English 60 Hz	Metric 60 Hz
Ventilation requirements				
a. Cooling airflow required - cfm - m ³ /min (unit mounted radiator)	13349	6301	17375	8201
b. Combustion air required - cfm - m ³ /min	953	450	1095	517
Total ventilation requirements - cfm - m³/min (a. + b.)	14302	6751	18470	8718
Maximum cooling air restriction - in.H ₂ O - in.hg	0.5	12.75	0.5	12.75
Recommended minimum intake louver size (based on "free area")	14.30	1.33	18.47	1.72
a. Heat rejected to ambient, engine - Btu/min - kWm	1024	18	1137	20
b. Heat rejected to ambient, generator - Btu/min - kWm	949	17	1138	20
Total heat rejection to ambient - Btu/min (a. + b.)	1973	35	2275	40
Exhaust system requirements				
Exhaust gas flow - cfm - m ³ /min	2225	1050	2543	1200
Exhaust temperature (dry manifold) - °F - °C	977	525	1049	565
Maximum back pressure - in.H ₂ O - mm H ₂ O (inclusive of silencer)	40.2	10	40.2	10
Exhaust outlet size - in. - mm	3.86	98	3.86	98
Emissions - NO _x - g/BHP-hr - g/kW-hr	Not Regulated		Meets EPA Tier Two Consult Factory for Actual Values	
Emissions - HC - g/BHP-hr - g/kW-hr				
Emissions - CO - g/BHP-hr - g/kW-hr				
Emissions - PM - g/BHP-hr - g/kW-hr				
Fuel system requirements				
Fuel consumption - 1/4 load - gph - Lph	6.06	22.93	7.18	27.16
Fuel consumption - 1/2 load - gph - Lph	12.12	45.87	14.35	54.33
Fuel consumption - 3/4 load - gph - Lph	18.18	68.80	21.53	81.49
Fuel consumption - Full load - gph - Lph	24.24	91.74	28.71	108.66
Heat Exchanger Cooling system requirements				
Minimum raw water (city water) flow - gpm - lps	Consult Factory	Consult Factory	Consult Factory	Consult Factory
Maximum supply water temperature - °F - °C	80°F	12.44°C	80°F	12.44°C
Remote Cooling system requirements				
Maximum coolant static head - ft. - m	17	5	17	5
Ventilation required (based on 25°F temp rise) - cfm - lps	4384	77	5056	89

Accessories and Options

Control Panel

- Louver Relay – 10 Amp
- Run Relay – 10 Amp
- Dry Contacts For Alarms
- Remote E-Stop
- Control Panel Heater
- Tachometer
- Remote Annunciator
- Remote Communication
- Panel Lights w/Switch
- Generator Voltage Adjust
- Modem For Remote Communication

Engine Exhaust System

- Industrial Silencer
- Residential Silencer
- Critical Silencer
- Exhaust Flex
- Exhaust Extension
- Rain Cap
- _____

Generator Accessories

- Main Line Circuit Breaker
- Exciter Field Circuit Breaker
- Ground Fault Module w/Breaker Shunt Trip
- Ground Fault Module w/o Breaker Shunt Trip
- Reconnectable Link Bars
- Drip Cover IP22
- Manual Voltage Control
- Space Heater
- RTD's Stator Windings
- RTD's Bearing (Rear)
- PMG
- MVC300 Manual Voltage Control

Engine Electrical System

- Batteries
- Battery Rack
- Battery Cables
- Battery Charger - Automatic
- Battery Charger - Trickle
- _____

Engine Fuel System

- Day Tank
- Sub-Base Fuel Tank
- Storage Tank
- Flexible Fuel Lines
- _____

Miscellaneous

- Weather Proof Enclosure
- Sound Attenuated Enclosure
- Trailer Mounted
- Vibration Isolators
- Coolant Heater
- Oil Heater
- Bypass Oil Filter
- Export Crating

- _____
- _____
- _____
- _____

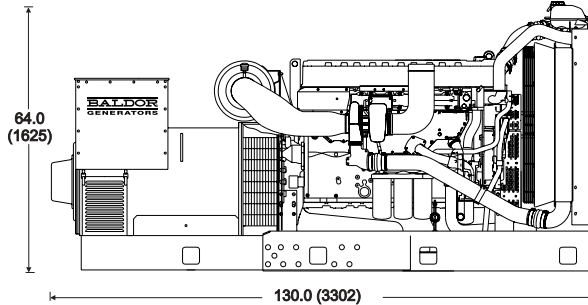
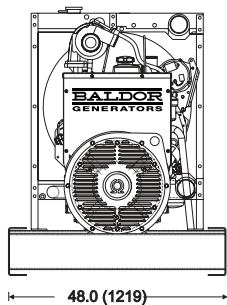

Dimensions – in (mm)

Weight – lbs. (Kg)
8384 (3802)

Cubes (Approximate)
210 ft

*Open unit configuration,
accessories not included

Distributed by:



3815 Oregon Street • Oshkosh, WI 54902 • 1-800-872-7697 • Phone (920) 236-4200 • Fax (920) 236-4219
909 Perkins Drive • Mukwonago, WI 53149 • Phone (262) 363-1555 • Fax (262) 363-1556

World Headquarters

Baldor Electric Company • P.O. Box 2400 • Fort Smith, AR 72902-2400 U.S.A.
Phone (479) 646-4711 • Fax (479) 648-5792 • International Fax (479) 648-5895

www.baldor.com