

Immersible Motors



PROVEN PERFORMANCE — EVEN UNDER THIRTY FEET.

The Baldor•Reliance® immersible motor is designed for use where the possibility of flooding exists. The motor features totally enclosed, blower-cooled enclosures and are designed with a unique sealing system. This system allows reliable operation for a period of two weeks while submerged under a maximum depth of thirty feet of water.

A diverse product line is offered to satisfy most demanding requirements:

- Horsepower range 5 to 250 Hp
- Frame range 210 to 449
- 3600, 1800, 1200, and 900 rpm
- 50 or 60 Hz

The immersible design has been proven by conducting extensive tests and inspections. The only way to claim that our motors will run underwater for two weeks is to imitate these same field conditions. At the conclusion of the testing, the motors are disassembled and inspected by engineers to assess dryness and structural integrity.

PREMIUM FEATURES:

- Premium efficient designs
- Variable frequency operation on variable torque applications
- Winding temperature detectors (thermostats)
- Space heater
- P-Base or C-face mounting
- Vertical or horizontal mounting available
- 25 foot power cable, other lengths available
- Patented immersible motor sealing system

Immersible motors are ideal for dry pit applications in flood plains. The motor exceeds the IP67 requirements of two weeks submersion at a depth of thirty feet.

IMMERSIBLE MOTOR RATINGS CAPABILITIES CHART - 460 VOLT, 3 PHASE

HP	3600RPM	1800 RPM	1200 RPM	900 RPM
	Frame	Frame	Frame	Frame
5	210	210	210	250
7.5	210	210	210	250
10	210	250	250	320
15	250	250	250	320
20	250	250	250	320
25	280	280	320	320
30	280	280	320	360
40	320	320	320	360
50	320	320	320	400
60	360	360	360	400
75	360	360	360	440
100	400	400	400	440
125	400	440	400	440
150	440	440	440	440
200	440	440	440	440
250	440	440	440	-

NOTES: 210 frame are TENV
 250 and above are TEBC



The totally enclosed blower-cooled immersible motor is equipped with a Baldor•Reliance ½ Hp motor for cooling. Once the motor is submerged, a float switch* disengages the blower motor. The blower motor must be inspected and replaced if necessary before re-starting the motor dry.

*Baldor does not provide the float switch.

This cutaway shows the typical construction for a vertical mount immersible motor. The unique sealing arrangement makes the immersible motor the ideal choice for applications where the possibility of flooding exists.

- | | |
|---|---|
| <ul style="list-style-type: none"> 1. Frame 2. Stator 3. "O" ring, seal carrier 4. Seal carriage 5. Seals 6. Shaft 7. Back end bracket 8. Conduit box, cable cap assembly | <ul style="list-style-type: none"> 9. Lifting Plates 10. Drip cover 11. Blower motor cable entry 12. Blower motor 13. Outer Fan 14. Front end ball bearing 15. Fan cover 16. Front end bracket 17. Rotor |
|---|---|

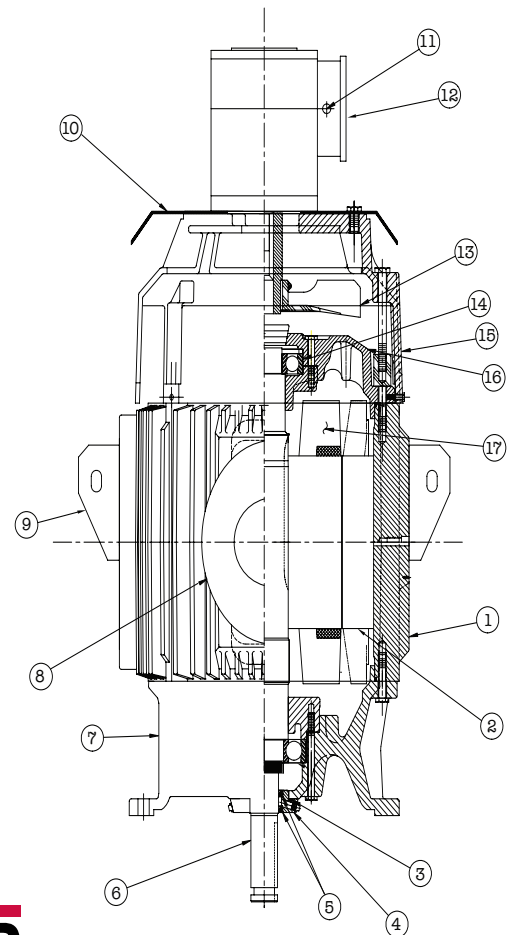

BALDOR

Baldor Electric Company

P.O. Box 2400 • Fort Smith, AR 72902-2400 U.S.A.

Phone (479) 646-4711 • Fax (479) 648-5792 • International Fax (479) 648-5895 • www.baldor.com