

QUANTIS®

GEARING

DODGE® QUANTIS® ILH IN-LINE HELICAL SINGLE REDUCTION

DODGE QUANTIS now offers Single Reduction as an option to complement our existing double and triple reduction In-Line Helical (ILH) gearing products. This gearbox can also be used in combination with ILH or Right Angle Helical Bevel (RHB) gearboxes to make a tandem QUANTIS gearbox achieving ratios greater than 300 to 1.

The QUANTIS Single Reduction ILH greatly extends DODGE's product offering in helical gearing solutions.



- ILH Sizes 38 – 88
- Output Shafts – Inch and Metric
- Output Flanges – B14, B5, and Nema
- Input HP Ratings up to 41hp
- Output Torque Ratings up to 3826 in-lbs
- 98% Efficiency
- Ratings for Single Reduction are in the Product Configurator

ILH Single Reduction - Size 38

All ratings at 1750 rpm input, output torque (in-lbs)

Ratio	Output RPM	56C 71D 71		80D 80		140TC 90D 90		180TC 100D 100	
		Input HP	Output Torque	Input HP	Output Torque	Input HP	Output Torque	Input HP	Output Torque
1.59	1101	2.02	116	2.46	141	4.84	277	8.87	508
1.85	946	2.02	134	2.46	164	4.60	306	8.37	557
2.05	854	2.02	149	2.46	182	4.42	327	8.01	592
2.24	781	2.02	163	2.46	198	4.27	343	7.73	622
2.50	700	2.02	182	2.46	221	4.06	366	7.18	646
2.73	641	1.99	196	2.46	242	3.90	384	7.06	695
3.00	583	1.91	206	2.46	266	3.73	403	6.55	708
3.31	529	1.82	217	2.46	293	3.55	423	4.83	575
3.67	477	1.73	228	2.34	309	3.37	445	4.69	620
4.15	422	1.61	241	2.18	326	3.16	473	3.67	549
4.58	362	1.53	252	2.06	340	3.01	497	4.18	690
5.18	338	1.41	262	1.92	359	2.81	523	3.32	620
5.92	296	1.26	269	1.77	377	2.20	469		–
6.73	260	1.13	275	1.62	394	1.75	425		–
7.20	243	1.07	278	1.30	336	1.30	336		–
8.30	211	0.95	283	0.95	283				–
9.33	188	0.84	283						–

ILH Single Reduction - Size 48

All ratings at 1750 rpm input, output torque (in-lbs)

Ratio	Output RPM	56C 71D 71		80D 80		140TC 90D 90		180TC 100D 100		112D 112	
		Input HP	Output Torque	Input HP	Output Torque	Input HP	Output Torque	Input HP	Output Torque	Input HP	Output Torque
1.52	1151	–	–	2.46	135	5.00	274	10.40	567	12.60	692
1.83	956	–	–	2.46	162	5.00	329	10.20	673	11.90	780
2.15	814	–	–	2.46	190	5.00	387	9.67	749	11.10	861
2.41	726	2.02	175	2.46	213	5.00	434	9.25	803	10.60	917
2.70	648	2.02	196	2.46	239	4.86	473	8.82	857	10.00	976
2.95	593	2.02	214	2.46	261	4.70	499	8.48	900	9.63	1022
3.24	540	2.02	235	2.46	286	4.51	526	8.13	947	9.22	1075
3.56	492	2.02	259	2.46	315	4.32	554	7.77	996	8.81	1130
3.87	452	2.02	281	2.46	342	4.15	579	7.47	1040	8.48	1181
4.21	416	2.02	306	2.46	373	3.98	604	7.17	1089	8.18	1241
4.62	379	1.96	325	2.46	408	3.80	632	6.89	1145	6.92	1151
5.08	344	1.82	334	2.46	450	3.61	662	5.80	1062	5.80	1062
5.85	299	1.63	343	2.31	487	3.36	706	5.04	1062	5.04	1062
6.33	276	1.53	348	2.21	504	3.23	736	4.46	1018	4.46	1018
7.00	250	1.40	354	2.09	526	3.05	768	3.41	859	–	–
8.17	214	1.23	363	1.89	557	2.56	752	–	–	–	–
9.09	193	1.12	368	1.73	566	1.73	566	–	–	–	–
10.00	175	1.03	372	1.66	598	1.97	708	–	–	–	–
11.30	155	0.93	377	1.20	487	–	–	–	–	–	–

ILH Single Reduction - Size 68

All ratings at 1750 rpm input, output torque (in-lbs)

Ratio	Output RPM	56C 71D 71		80D 80		140TC 90D 90		180TC 100D 100		112D 112		210TC 132D 132	
		Input HP	Output Torque	Input HP	Output Torque	Input HP	Output Torque	Input HP	Output Torque	Input HP	Output Torque	Input HP	Output Torque
1.41	1241	–	–	–	–	–	–	10.36	526	13.87	704	22.38	1136
1.70	1029	–	–	–	–	–	–	10.36	634	13.83	847	21.10	1292
2.04	858	–	–	2.46	181	5.00	368	10.36	761	13.07	961	19.74	1450
2.39	732	–	–	2.46	212	5.00	431	9.90	852	12.33	1062	18.46	1590
2.85	614	–	–	2.46	252	5.00	514	9.24	948	11.46	1177	17.04	1749
3.09	566	2.02	225	2.46	274	4.86	541	8.92	993	11.05	1230	16.41	1827
3.45	507	2.02	251	2.46	305	4.65	577	8.47	1053	10.49	1303	15.60	1938
3.74	468	2.02	272	2.46	331	4.48	604	8.15	1096	10.09	1358	15.05	2026
4.24	413	2.02	308	2.46	375	4.22	644	7.64	1166	9.47	1445	13.35	2036
4.56	384	2.02	332	2.46	404	4.07	668	7.36	1209	9.15	1503	11.85	1947
4.93	355	2.02	359	2.46	437	3.90	693	7.06	1255	8.81	1566	11.21	1991
5.36	326	2.02	389	2.46	474	3.73	720	6.78	1308	8.50	1641	10.09	1947
5.92	296	1.93	413	2.46	524	3.53	752	6.44	1375	7.88	1682	7.88	1682
6.42	273	1.85	428	2.46	568	3.37	779	6.22	1438	6.51	1505	6.51	1505
7.23	242	1.73	451	2.32	604	3.16	822	5.10	1328	5.10	1328	–	–
7.92	221	1.65	469	2.19	625	3.00	856	5.28	1505	5.28	1505	–	–
8.82	198	1.55	491	2.06	653	2.81	892	4.18	1328	–	–	–	–
10.08	174	1.43	518	1.88	684	2.32	841	–	–	–	–	–	–
11.18	157	1.33	536	1.75	706	2.02	814	–	–	–	–	–	–
12.40	141	1.24	553	1.53	684	1.61	717	–	–	–	–	–	–

ILH Single Reduction - Size 88

All ratings at 1750 rpm input, output torque (in-lbs)

Ratio	Output RPM	140TC 90D 90		180TC 100D 100		112D 112		210TC 132D 132		250TC 160D 160	
		Input HP	Output Torque	Input HP	Output Torque	Input HP	Output Torque	Input HP	Output Torque	Input HP	Output Torque
1.71	1023	-		-		13.87	856	25.09	1549	41.56	2566
2.09	837	-		10.36	780	13.87	1044	23.80	1792	38.91	2930
2.45	714	-		10.36	914	13.87	1224	22.58	1993	36.58	3228
2.88	608	5.00	519	10.36	1074	13.87	1438	21.24	2203	34.17	3544
3.30	530	5.00	595	10.36	1233	13.53	1610	20.02	2383	32.15	3826
3.90	449	5.00	703	10.22	1436	12.65	1777	18.53	2603	24.26	3408
4.23	414	5.00	762	9.88	1504	12.21	1858	17.84	2716	23.25	3540
4.70	372	4.85	822	9.43	1595	11.62	1967	16.97	2873	20.13	3408
5.11	342	4.68	860	9.06	1666	11.17	2054	16.34	3004	17.81	3275
5.65	310	4.46	906	8.63	1755	10.64	2164	13.93	2832	13.93	2832
6.06	289	4.30	939	8.34	1820	10.30	2249	11.35	2478	11.35	2478
6.53	268	4.13	972	8.03	1890	9.96	2343	11.28	2655	-	
7.07	248	3.96	1008	7.74	1970	9.64	2454	10.08	2567	-	
7.69	228	3.78	1047	7.45	2063	7.83	2168	7.83	2168	-	
8.42	208	3.59	1089	7.15	2168	7.15	2168	7.15	2168	-	
9.46	185	3.37	1147	5.45	1859	5.45	1859	-		-	
10.33	169	3.21	1195	5.47	2036	5.47	2036	-		-	



DODGE®
Quantis®
 MODULAR GEARING SOLUTIONS

IN-LINE HELICAL GEAR REDUCER (ILH) - SINGLE REDUCTION

NEMA C-FACE - FOOT MOUNTED - CLAMP COLLAR / 3 PIECE COUPLED

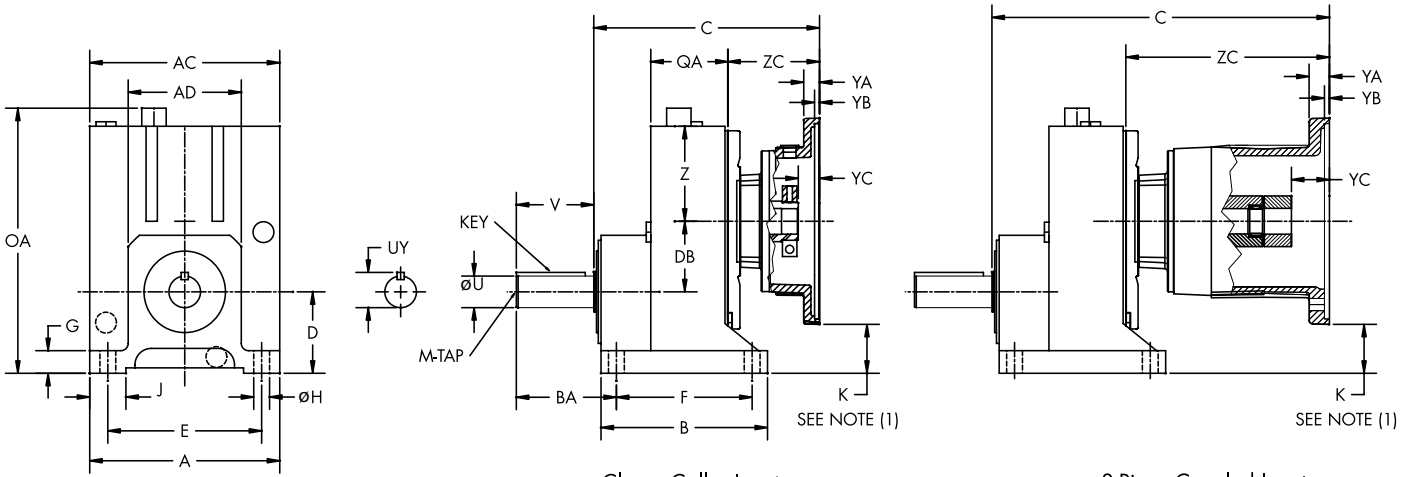

STANDARD OUTPUT SHAFT

Size	ØU	tol.	UY	V	Key	M-Tap
38	0.875	+0.000 -0.001	0.95	2.24	3/16 x 3/16 x 1.50	5/16-18 UNC
48	1.125	+0.000 -0.001	1.23	2.74	1/4 x 1/4 x 2.35	3/8-16 UNC
68	1.375	+0.000 -0.001	1.51	3.37	5/16 x 5/16 x 3.00	3/8-16 UNC
88	1.625	+0.000 -0.001	1.79	3.15	3/8 x 3/8 x 2.75	5/8-11 UNC

GEARCASE

Size	A	AC	AD	B	BA	D	E	F	G	ØH	J	OA	DB	Z	QA
38	6.1	5.1	3.6	5.4	2.9	2.2	4.92	4.33	0.7	0.43	1.4	7.5	1.93	2.6	2.34
48	6.7	6.7	3.8	6.0	3.8	3.2	5.31	4.72	0.8	0.53	1.5	9.9	2.54	3.4	2.60
68	8.3	8.3	5.0	7.3	4.4	3.6	6.69	5.91	1.0	0.69	1.6	11.6	3.07	4.2	3.35
88	10.3	10.3	6.3	8.1	4.4	4.0	8.46	6.30	1.2	0.69	2.4	13.8	3.90	5.2	3.86

NEMA MOTOR ADAPTER - CLAMP COLLAR

	38			48			68			88			YA	YB	YC
	C	ZC	K (1)	C	ZC	K	C	ZC	K	C	ZC	K			
56C	7.8	3.5	0.9	7.6	3.3	2.4	8.9	3.1	3.4	-	-	-	0.47	0.20	0.67
140TC	8.5	4.2	0.9	8.3	4.0	2.4	9.6	3.7	3.4	9.5	3.1	4.6	0.47	0.20	0.67
180TC	8.8	4.5	-0.4	9.9	5.5	1.2	11.0	5.2	2.2	10.9	4.5	3.4	0.69	0.22	0.93
210TC	-	-	-	-	-	-	12.9	7.1	2.1	12.8	6.4	3.4	0.69	0.22	0.89
250TC	-	-	-	-	-	-	-	-	-	12.7	6.3	2.8	0.94	0.20	1.13

NEMA MOTOR ADAPTER - 3 PIECE COUPLED

	38			48			68			88			YA	YB	YC
	C	ZC	K	C	ZC	K	C	ZC	K	C	ZC	K			
56C	11.0	6.6	0.9	10.8	6.4	2.4	12.0	6.2	3.4	-	-	-	0.55	0.20	1.08
140TC	12.4	8.1	0.9	12.2	7.8	2.4	13.4	7.6	3.4	13.4	7.0	4.6	0.55	0.20	1.10
180TC	-	-	-	13.4	9.1	1.2	14.6	8.8	2.2	14.5	8.1	3.4	0.73	0.22	1.65
210TC	-	-	-	-	-	-	16.8	11.0	2.2	16.6	10.2	3.4	0.87	0.22	2.01
250TC	-	-	-	-	-	-	-	-	-	18.5	12.2	2.8	0.94	0.20	2.17

(1) A negative number indicates the flange extends below the reducer feet. Depending on the motor, portions of the motor may extend further below the feet and require spacer blocks to avoid clearance problems.

IN-LINE HELICAL GEAR REDUCER (ILH) - SINGLE REDUCTION

NEMA C-FACE - FLANGE MOUNTED - CLAMP COLLAR / 3 PIECE COUPLED - B14 Flange

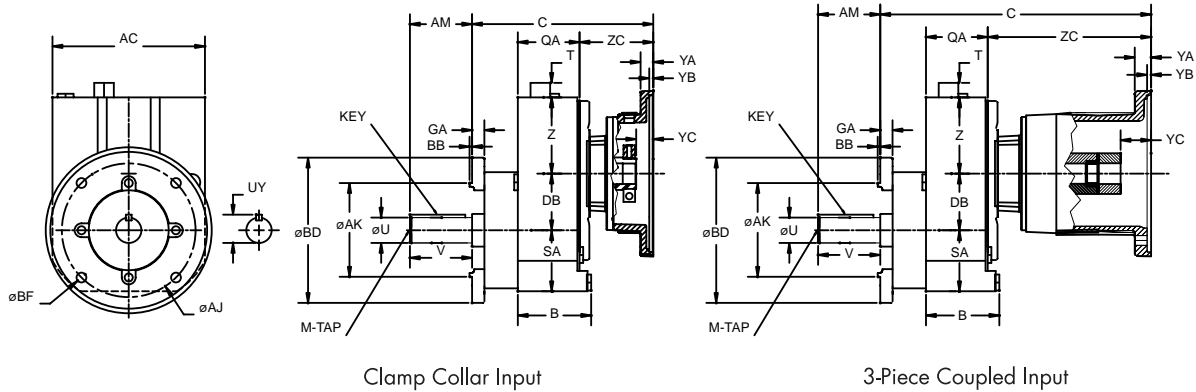

Clamp Collar Input

3-Piece Coupled Input

STANDARD OUTPUT SHAFT

Size	øU	tol.	UY	V	Key	M-Tap
38	0.875	+0.000 -0.001	0.95	2.24	3/16 x 3/16 x 1.50	5/16-18 UNC
48	1.125	+0.000 -0.001	1.23	2.74	1/4 x 1/4 x 2.35	3/8-16 UNC
68	1.375	+0.000 -0.001	1.51	3.37	5/16 x 5/16 x 3.00	3/8-16 UNC
88	1.625	+0.000 -0.001	1.79	3.15	3/8 x 3/8 x 2.75	5/8-11 UNC

GEARCASE / FLANGE

Size	Output Flange	øAJ	øAK	tol.	BB	AM	BD	øBF	AC	B	QA	SA	DB	Z	T
38	B14 120MM	3.937	3.1496	+0.0005 -0.0003	0.35	2.75	4.8	M8 x 1.25	5.1	2.3	2.4	2.4	1.93	2.6	0.9
48	B14 120MM	3.937	3.1496	+0.0005 -0.0003	0.35	3.25	4.8	M8 x 1.25	6.7	3.2	2.6	3.0	2.54	3.4	0.9
68	B14 160MM	5.118	4.3307	+0.0005 -0.0004	0.45	4.04	6.3	M10 x 1.5	8.3	4.0	3.4	3.4	3.07	4.2	0.9
88	B14 190MM	6.496	5.1181	+0.0006 -0.0004	0.41	3.86	7.5	M12 x 1.75	10.3	4.4	3.9	4.2	3.90	5.2	0.9

NEMA MOTOR ADAPTER - CLAMP COLLAR

	38		48		68		88		YA	YB	YC
	C	ZC	C	ZC	C	ZC	C	ZC			
56C	7.3	3.5	7.1	3.3	8.2	3.1	-	-	0.47	0.20	0.67
140TC	8.0	4.2	7.8	4.0	8.9	3.7	8.8	3.1	0.47	0.20	0.67
180TC	8.3	4.5	9.4	5.5	10.4	5.2	10.2	4.5	0.69	0.22	0.93
210TC	-	-	-	-	12.3	7.1	12.0	6.4	0.69	0.22	0.89
250TC	-	-	-	-	-	-	12.0	6.3	0.94	0.20	1.13

NEMA MOTOR ADAPTER - 3 PIECE COUPLED

	38		48		68		88		YA	YB	YC
	C	ZC	C	ZC	C	ZC	C	ZC			
56C	10.5	6.6	10.2	6.4	11.3	6.2	-	-	0.55	0.20	1.08
140TC	11.9	8.1	11.7	7.8	12.8	7.6	12.7	7.0	0.55	0.20	1.10
180TC	-	-	12.9	9.1	14.0	8.8	13.7	8.1	0.73	0.22	1.65
210TC	-	-	-	-	16.1	11.0	15.9	10.2	0.87	0.22	2.01
250TC	-	-	-	-	-	-	17.8	12.2	0.94	0.20	2.17

IN-LINE HELICAL GEAR REDUCER (ILH) - SINGLE REDUCTION

NEMA C-FACE - FLANGE MOUNTED - CLAMP COLLAR / 3 PIECE COUPLED - B5 and NEMA Flange

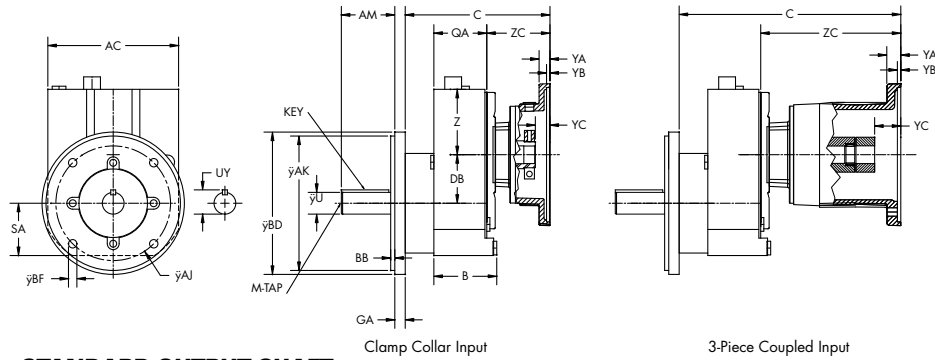

STANDARD OUTPUT SHAFT

Size	øU	tol.	UY	V	Key	M-Tap
38	0.875	+0.000 -0.001	0.95	2.24	3/16 x 3/16 x 1.50	5/16-18 UNC
48	1.125	+0.000 -0.001	1.23	2.74	1/4 x 1/4 x 2.35	3/8-16 UNC
68	1.375	+0.000 -0.001	1.51	3.37	5/16 x 5/16 x 3.00	3/8-16 UNC
88	1.625	+0.000 -0.001	1.79	3.15	3/8 x 3/8 x 2.75	5/8-11 UNC

GEARCASE / FLANGE

Size	Output Flange	øAJ	øAK	tol.	BB	GA	AM	øBD	øBF	AC	B	QA	SA	DB	Z	T
38	NEMA 140TC	5.875	4.5000	+0.0000 -0.0030	0.15	0.7	2.12	6.5	0.41	5.1	2.3	2.4	2.4	1.93	2.6	0.9
	B5 160MM	5.118	4.3307	+0.0005 -0.0004	0.14	0.4	2.24	6.3	0.35	5.1	2.3	2.4	2.4	1.93	2.6	0.9
	B5 200MM	6.496	5.1181	+0.0006 -0.0004	0.14	0.5	2.24	7.9	0.43	5.1	2.3	2.4	2.4	1.93	2.6	0.9
48	NEMA 180TC	7.250	8.5000	+0.0000 -0.0030	0.26	0.4	2.88	9.0	0.53	6.7	3.2	2.6	3.0	2.54	3.4	0.9
	B5 160MM	5.118	4.3307	+0.0005 -0.0004	0.14	0.4	2.74	6.3	0.35	6.7	3.2	2.6	3.0	2.54	3.4	0.9
	B5 200MM	6.496	5.1181	+0.0006 -0.0004	0.14	0.5	2.74	7.9	0.43	6.7	3.2	2.6	3.0	2.54	3.4	0.9
68	NEMA 210TC	7.250	8.5000	+0.0000 -0.0030	0.26	0.7	3.38	9.0	0.53	8.3	4.0	3.4	3.4	3.07	4.2	0.9
	B5 200MM	6.496	5.1181	+0.0006 -0.0004	0.14	0.5	3.37	7.9	0.43	8.3	4.0	3.4	3.4	3.07	4.2	0.9
	B5 250MM	8.465	7.0866	+0.0006 -0.0004	0.16	0.6	3.37	9.9	0.53	8.3	4.0	3.4	3.4	3.07	4.2	0.9
88	B5 250MM	8.465	7.0866	+0.0006 -0.0004	0.16	0.6	3.15	9.9	0.53	10.3	4.4	3.9	4.2	3.90	5.2	0.9
	B5 300MM	10.433	9.0551	+0.0006 -0.0005	0.16	0.7	3.15	11.9	0.53	10.3	4.4	3.9	4.2	3.90	5.2	0.9

NEMA MOTOR ADAPTER - CLAMP COLLAR

	38		48		68		88		YA	YB	YC
	C	ZC	C	ZC	C	ZC	C	ZC			
56C	7.3	3.5	7.1	3.3	8.2	3.1	-	-	0.47	0.20	0.67
140TC	8.0	4.2	7.8	4.0	8.9	3.7	8.8	3.1	0.47	0.20	0.67
180TC	8.3	4.5	9.4	5.5	10.4	5.2	10.2	4.5	0.69	0.22	0.93
210TC	-	-	-	-	12.3	7.1	12.0	6.4	0.69	0.22	0.89
250TC	-	-	-	-	-	-	12.0	6.3	0.94	0.20	1.13

NEMA MOTOR ADAPTER - 3 PIECE COUPLED

	38		48		68		88		YA	YB	YC
	C	ZC	C	ZC	C	ZC	C	ZC			
56C	10.5	6.6	10.2	6.4	11.3	6.2	-	-	0.55	0.20	1.08
140TC	11.9	8.1	11.7	7.8	12.8	7.6	12.7	7.0	0.55	0.20	1.10
180TC	-	-	12.9	9.1	14.0	8.8	13.7	8.1	0.73	0.22	1.65
210TC	-	-	-	-	16.1	11.0	15.9	10.2	0.87	0.22	2.01
250TC	-	-	-	-	-	-	17.8	12.2	0.94	0.20	2.17

Note: C dimension gives length from input flange to output shaft shoulder. Overall length of unit is equal to C + V.

ILH SINGLE REDUCTION OIL FILL LEVELS & FILL VOLUMES FLANGED AND FOOT MOUNTED – SIZES 38-88

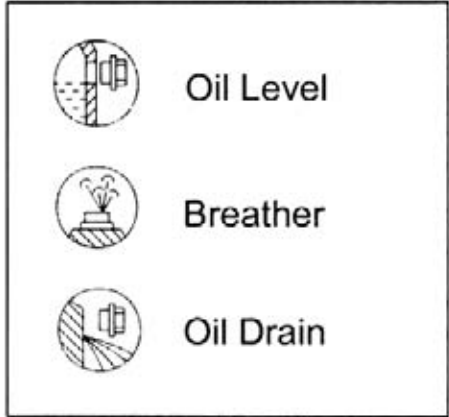
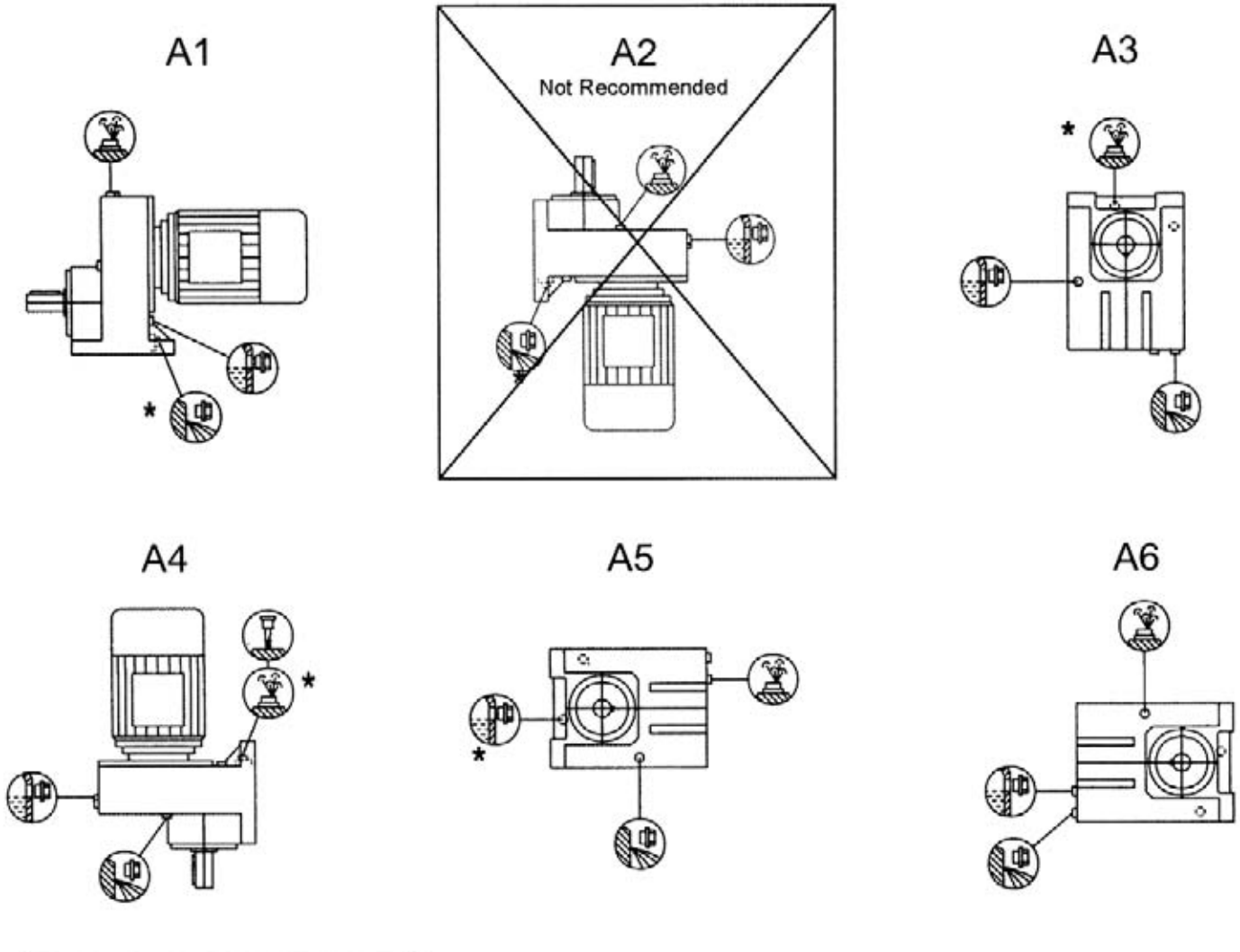

ESTIMATED** OIL FILL VOLUME REQUIREMENTS (PINTS)

Position	38	48	68	88
A1	0.3	0.5	1.1	1.6
A2	1.2	2.2	3.9	8
A3	0.8	1.5	3.1	5.3
A4	1	1.5	3.7	4.9
A5	0.5	1.2	2.1	3.3
A6	0.5	1	2.2	3.4

*On opposite side.
**These volumes are approximated. Fill bottom of hole marked 'Oil Level'.

Note: Factory fill levels are based on product ordering information. If the actual mounting position differs from the ordered fill, adjust volumes accordingly.



World Headquarters

P.O. Box 2400, Fort Smith, AR 72902-2400 U.S.A., Ph: (1) 479.646.4711, Fax (1) 479.648.5792, International Fax (1) 479.648.5895

Baldor - Dodge

6040 Ponders Court, Greenville, SC 29615-4617 U.S.A., Ph: (1) 864.297.4800, Fax: (1) 864.281.2433

www.baldor.com