

# Baldor Severe Duty Motors



**BALDOR**<sup>®</sup>  
MOTORS • DRIVES • GENERATORS

## Why Baldor?

For over 80 years, Baldor has strived to provide customers with the best value and reliability in industrial electric motors. That dedication shows in customer preference for Baldor motors. To be considered as the most preferred...

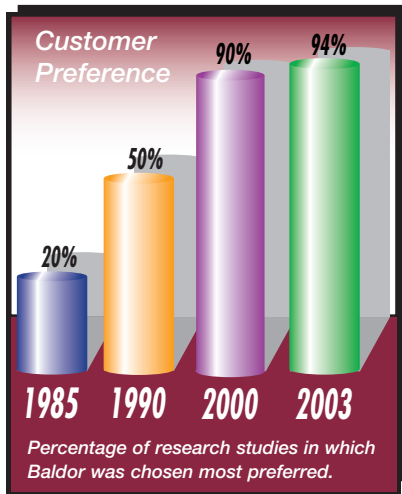

**Baldor offers the industry's broadest line of stock products.** Save valuable time with just one call to Baldor. We offer more than 6,000 stock motors, drives and gearboxes.

**Energy-efficiency leader.** We began lowering the energy consumption of our motors in the 1920s, long before others were even talking about it. Today, our expansive line of Super-E® premium-efficient motors ranges from 1 through 1500 hp. Baldor's Super-E® line offers customers the highest overall efficiency levels in the industry.

**Baldor products are available at more locations than any other brand.**



Our 40 district offices across North America offer immediate availability of Baldor products to thousands of distributors.

**Continuous innovation to improve reliability.**

Baldor leads the motor industry in applying new technologies and materials to improve motor reliability. Baldor was the first to introduce ISR® (Inverter Spike Resistant®) magnet wire, which is up to 100 times more resistant to voltage spikes. Baldor was first to use Exxon's new Polyrex® EM grease, which protects motor bearings better, providing improved lubrication life, greater shear stability, and superior resistance to washout, rust and corrosion.

**Industry's shortest lead times/Flexible manufacturing.**

Baldor has the industry's shortest lead times on custom motors – just ten working days. Our unique FLEX FLOW™ manufacturing process lets us produce any order in any quantity, quickly and efficiently.



**Industry's best information.** Only Baldor offers customers so many choices for product information with a wide variety of catalogs and product brochures, a CD-ROM electronic catalog, the Baldor Web site ([www.baldor.com](http://www.baldor.com)), or you may talk to a Baldor customer service person at one of our sales offices.

## Table of Contents

	<u>Page</u>
<b>Specifications and Features</b>	
• Design Features	4
• ISR® Wire / POLYREX®EM Grease	6
• Energy Savings	7
• Severe Duty Motor Construction	8
• Conduit Box Volumes	23
• Inverter and Vector Controls	24
• Matched Performance	25
<b>Stock and Custom HP/Frame Size Capabilities</b>	9
<b>Motor Performance Data</b>	
• IEEE 841 Premium Efficient Severe Duty	10
• Premium Efficient Severe Duty	13
• Standard Efficient Severe Duty	17
• Dirty Duty	19
• Quarry Duty	20
• Crusher Duty	20
• Explosion-Proof	21
• P-Base Vertical Pump	22
<b>Motor Dimensions</b>	26-32
<b>Connection Diagrams</b>	33

## Baldor Severe Duty Motors

When Baldor introduced its first Chemical Processing motor nearly forty years ago, the mission was clear: Provide a reliable and efficient motor, built rugged enough for a wide range of processing applications. Customer response was good, but many customers then came to Baldor for help in meeting the very specific challenges of their industry.

With that first Chemical Processing motor – and a long-standing commitment to listening to customers – Baldor's Severe Duty family has grown to include motors designed for a variety of processing industries worldwide.

### Over 400 Stock Motor Ratings

Today, Baldor offers customers a wide range of Severe Duty motors directly from stock, including your choice of premium efficient or standard efficient motors, in ratings from 1/2 to 1500 horsepower. Non-stock motors are delivered in just ten working days. All Baldor Severe Duty motors (except Explosion-Proof) are "Inverter-Ready."

### The Right Severe Duty Motor for your Application

Whether it's a standard efficient motor operating at a rock crusher in a quarry, or an IIEEE 841 motor operating continually in paper mill, Baldor offers customers a variety of choices.

Standard Efficient Chemical Processing motors are designed for general processing industry applications requiring protection from severe environmental operating conditions. In applications where the motor works continually and energy efficiency is a consideration, Baldor Super-E Chemical Processing motors are available in TEFC ratings from 1 through 900 hp. Cast-iron construction, two-part epoxy zinc chromate primer inside and out, and gaskets on all joints are some of the features of Baldor's Chemical Processing motors.

For the ultimate in protection from severe environments – where you need added insurance against downtime – Baldor offers IIEEE 841 motors. Delivering reliable, rugged performance with the industry's highest energy efficiencies, these motors exceed IIEEE 841 – 2001 standards for severe duty TEFC induction motors.

Baldor also offers a variety of special-purpose severe duty motors, including Dirty Duty™, Quarry Duty, Crusher Duty, Explosion-Proof and Vertical Shaft Pump motors.

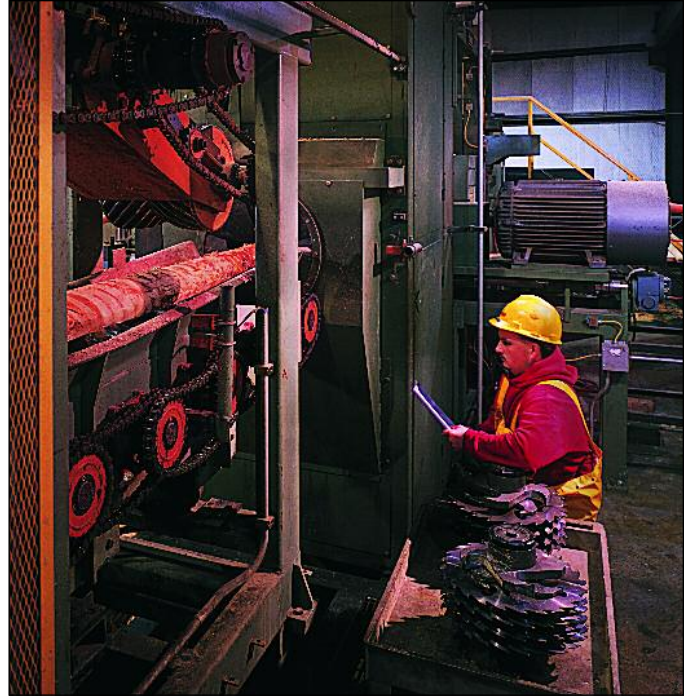

A Baldor 500 hp, medium voltage Chemical Processing Motor (pictured at the back end of the machine) and Series 22H Line Regen Vector Control run this chipping machine at a North Carolina lumber mill. High performance and reliability are the hallmarks of this Baldor motor, running in multiple shifts, under high-torque demands, exposed to sawdust and other airborne contaminants.

### Leadership in Premium Efficiency

The Consortium for Energy Efficiency (CEE) is a non-profit organization whose mission is to increase the use of energy-efficient products and services. In 1998, the CEE recognized Baldor's Super-E as the first premium efficient motor line to meet their stringent efficiency criteria, citing "For the first time, one manufacturer will carry all qualifying products."

As countries and regions across the world establish minimum efficiency levels for motors, more companies are turning to the Baldor Super-E. This includes plant and processing applications, as well as OEM products for shipment overseas. Super-E motors exceed the efficiency levels defined by EPA in the U.S., NRC in Canada, and CEMEP eff1 in Europe.

A wide selection of premium efficient motors, available from stock, manufactured and sold by a company committed to building better products for industries worldwide. No wonder, since the 1920s, Baldor is recognized as the leader in energy efficient motors and drives.

## Severe Duty Motors: Built for Reliable Performance

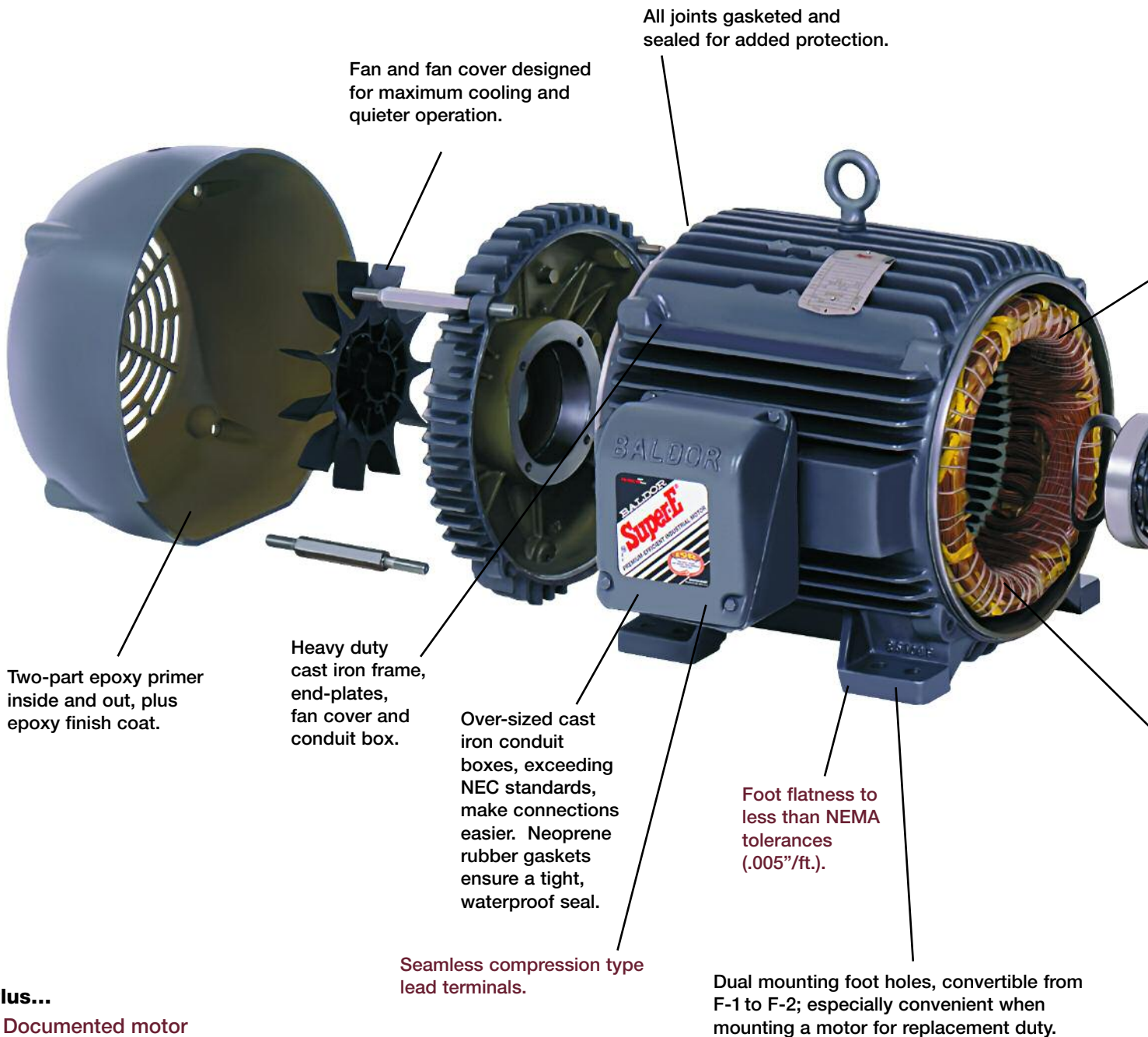

### Plus...

- Documented motor performance and vibration test date shipped with motor
- Shaft run-out less than NEMA
- Sound power level less than 90 dBA
- Five-year warranty

- Features found in Chemical Processing and IEEE 841 motors.
- Features found only in IEEE 841 motors.

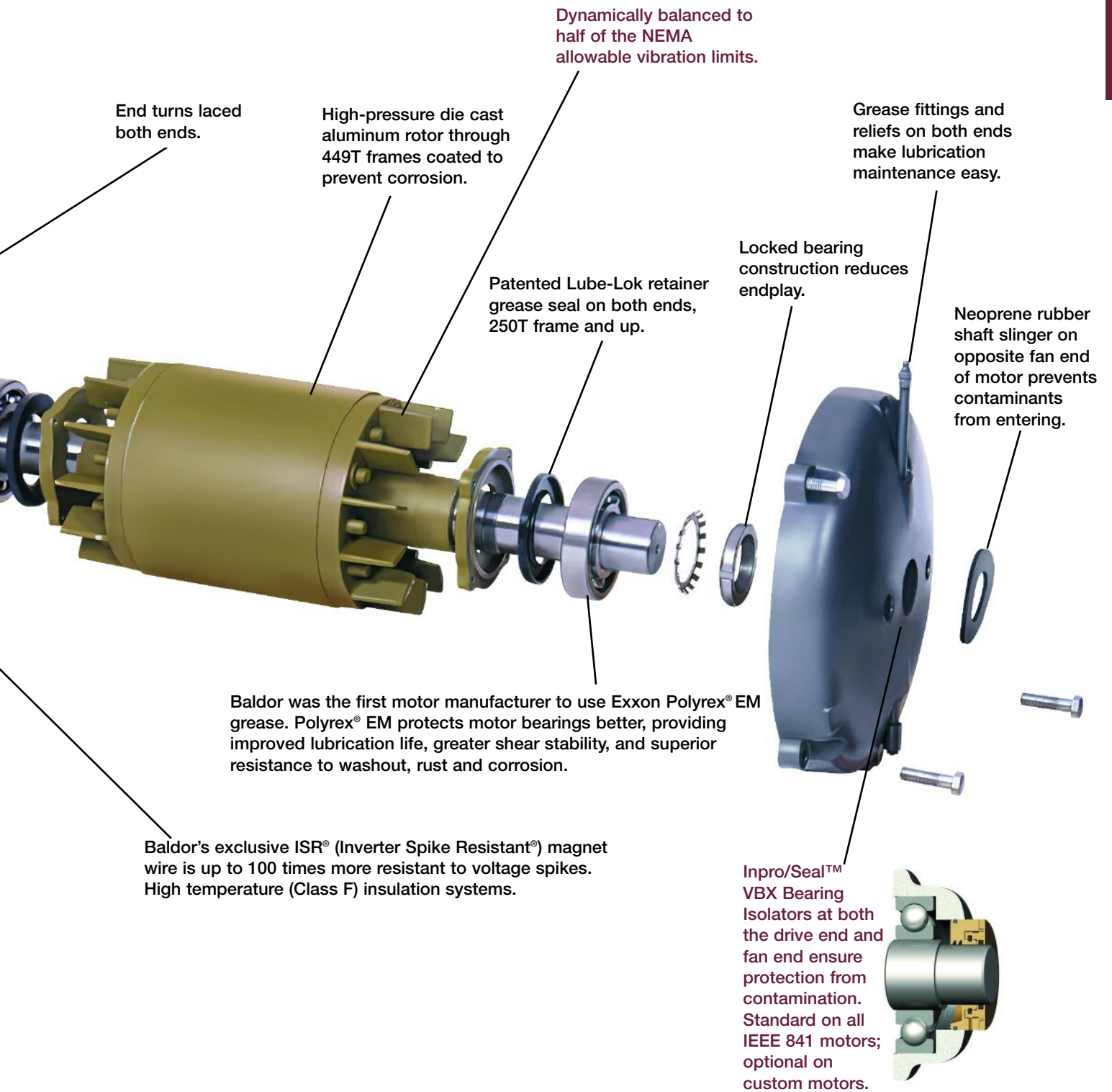

## Going Beyond the Industry Standard in Severe Duty Motors

Baldor's Severe Duty motors are another example of our commitment to provide reliable performance, while exceeding customer expectations.



### Wound with ISR® (Inverter Spike Resistant®) Magnet Wire

Recognized as "Product of the Year" by *Plant Engineering* magazine in 1996, Baldor's ISR wire is a standard feature in Baldor AC motors, 575 volt and under, 1 hp and up.

Motors wound with ISR wire are up to 100 times more resistant to transient voltage spikes, high frequencies and short rise time pulse frequently produced by inverters and vector drives. The result is a better motor with longer life, reduced downtime and better overall value.

#### ISR® Wire is Superior in Pulse Endurance Test

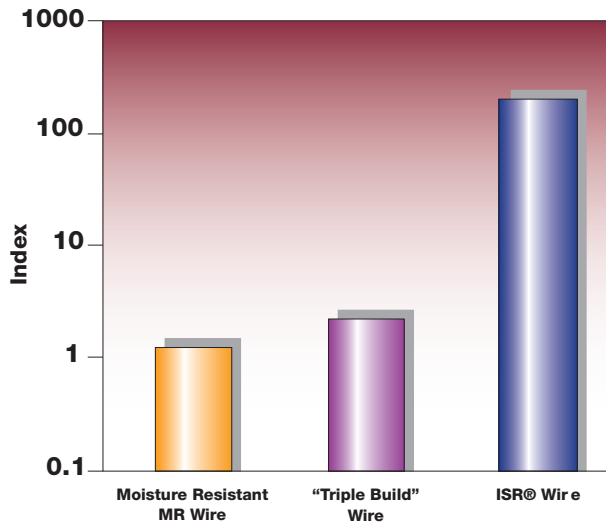

**Technical Specifications:**  
NEMA MW-35

**Pulse Endurance Test Conditions:**  
Twisted pairs @ 20,000 Hz, 2 kV, 0.025 microsecond risetime, 50% duty cycle, 90°C

**Pulse Endurance Index =**  
Life of Product/Life of 18 H MW-35 (Reference)

**Thermal Properties, Chemical Resistance and Dielectric Strength:**  
ISR® Wire is equal to or better than MR wire.

**Thermal Rating:** 200°C

**Source:**  
Phelps Dodge Magnet Wire Company (Used with permission)

### Standard on All Baldor Motors: Exxon Polyrex® EM Polyurea Grease

It's a fact: Bearing failure is the #1 mechanical reason for motor failure. So the better the grease protecting those bearings, the better and longer the motor performs.

Today, that better grease is Exxon's new Polyrex® EM polyurea grease – now standard on all Baldor motors. It provides lubrication life of more than four times greater than other polyurea greases in tests up to 350°F. It exhibits greater durability when subjected to mechanical shearing forces. Furthermore, a specially formulated additive in the grease resists washout, rust and corrosion even when subjected to salt water conditions.



#### Excellent Shear Stability

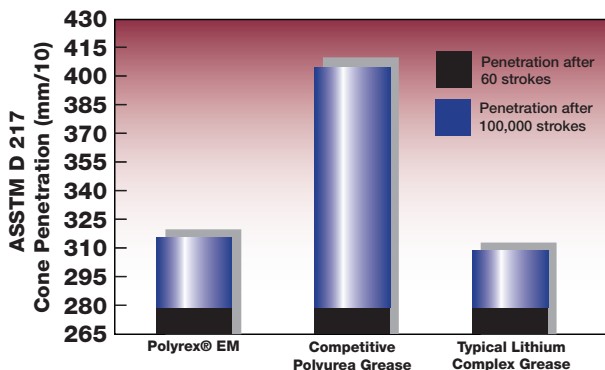

As illustrated here, the proprietary polyurea thickener system in Polyrex EM exhibits excellent durability and stability when subjected to a mechanical shearing force. Mechanical shear stability is a measurement of the greases thickener system. Good mechanical shear stability is important in roller bearing applications where excessive grease softening may lead to grease leakage or purging from the bearing.

Source: Exxon Mobil Product Data Sheet DG-3C, 6/15/99.

#### Outstanding High-Temperature Lubrication Life

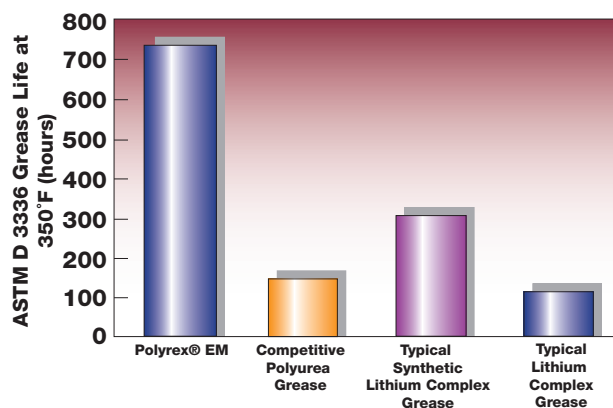

In the severe ASTM D 3336 High-Temperature Grease Life Test, Polyrex EM dramatically out performed a competitive polyurea grease and conventional lithium-complex greases.

Source: Exxon Mobil Product Data Sheet DG-3C, 6/15/99.

## Making Energy Efficiency Work For You

### Why is Energy Efficiency Important?

Electric motor-driven systems used in industrial processes consumed 679 billion kWh, or 63% of all electricity used in U.S. industrial sector, according to a U.S. Department of Energy report published in 1998. The report goes on to reveal that industrial motor energy could be reduced by up to 18 percent if companies were to apply motor and motor system efficiency upgrades, including the use of adjustable speed drives. The potential positive impacts on companies' bottom lines and the environment are significant.

### Purchase Price is Only a Small Piece of the Pie

The pie chart to the right shows the typical life cycle cost of a 100 hp motor operating in continuous duty over a 20-year life. As you can see, the original purchase price is almost insignificant compared to what it will cost to power the motor during its useful life.

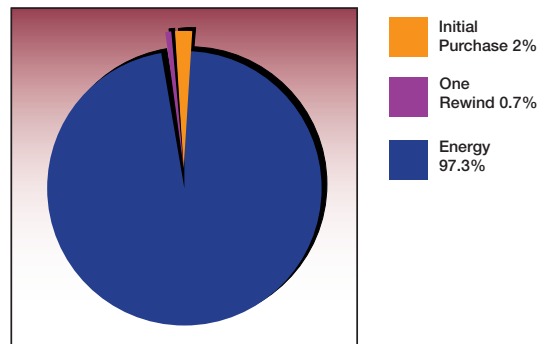

### How Baldor Super-E® Efficiencies Compare to Industry Standards

Baldor's line of Super-E motors offers customers the highest level of overall efficiencies available from any motor manufacturer.

### BE\$T™ Baldor Energy Savings Tool Makes Calculating Payback Easy

In order to make payback calculations easier for customers, Baldor developed BE\$T, Baldor Energy Savings Tool. The software helps calculate energy cost and energy savings for motors, as well as payback timeframes. A popular feature of BE\$T is that it allows users to make head-to-head comparisons of up to three motors, giving customers the information to make an informed decision through comparative analysis.

BE\$T, Baldor Energy Savings Tool is available as a download through Baldor's award-winning Web site ([www.baldor.com/support/index.asp](http://www.baldor.com/support/index.asp)), as well as a stand-alone 3.5" diskette or on Baldor's popular CD-ROM, both available from the Baldor Literature Hotline (1-800-828-4920).

### Electric Motor Efficiency Ratings

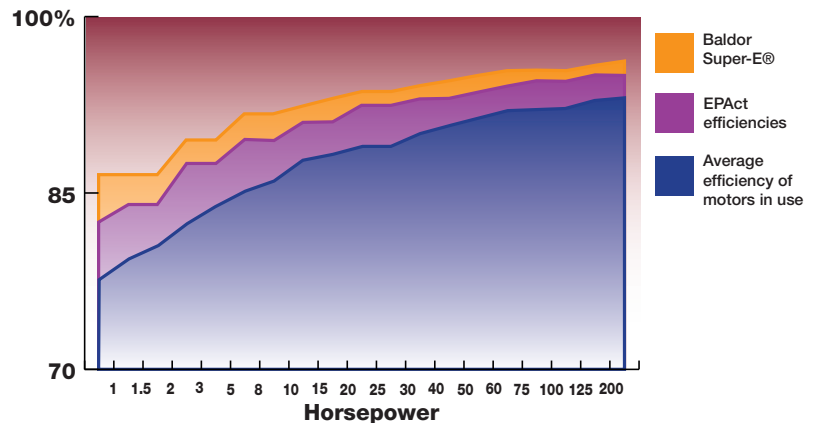

### What is Higher Efficiency Worth?

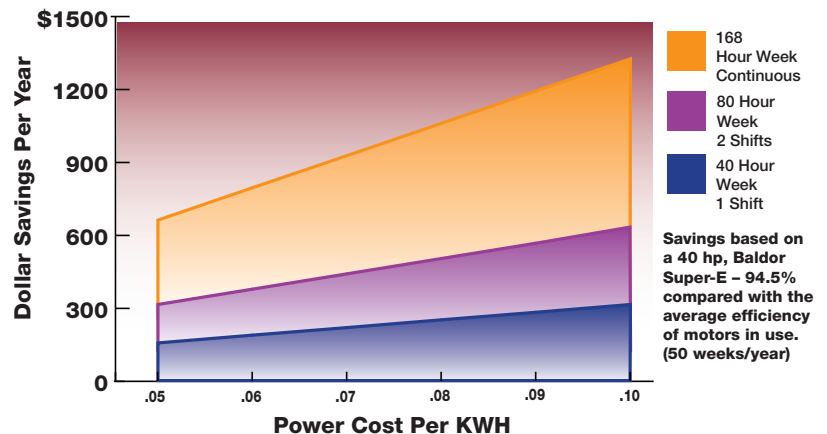

## Severe Duty Motor Construction

Baldor Severe Duty motors share a number of electrical and mechanical features that add up to outstanding value. "ECP" Chemical Processing motors provide an extra measure of weather and chemical protection in a premium energy efficient design. For the most extreme applications, where downtime is critical, Baldor "ECP-841" motors are ideal. These are premium efficient motors that exceed IEEE 841-2001 specifications. Standard efficient Severe Duty motors include "CP" Chemical Processing motors, and Dirty Duty™ motors. The chart below lists standard features ("S") in Baldor Severe Duty motors. Horsepower ranges indicate where certain features are standard in stock products. Additional features are optional ("O") on built-to-order motors.

### TEFC Severe Duty Motor Family

Electrical Features	Premium Efficiency		Standard Efficiency	
	ECP	ECP - 841	CP	Dirty Duty
HP Range - Stock	1 - 500	1 - 250	1 - 100	1/2 - 10
HP Range - Custom	1/2 - 1500	1/2 - 1500	1 - 1500	1/2 - 10
NEMA Premium™ Efficiency	S	S		
Class F insulation with Class B rise	S	S		
1.15 Service factor	S	S	S	S
200°C Inverter Spike Resistant magnet wire	S	S	S	S
Phase insulation	S	S	S	S
Seamless compression type lead terminals		S		
Corona inception testing - meets NEMA Part 31.4.4.2	S	S	S	S
Double dip & bake with 100% solids	S	S	S	S
Document final motor tests - ship sheet with motor		S		
<b>Mechanical Features</b>				
NEMA Frame sizes	143T - 5812	143T - 5812	143T - 5812	56 - 447T
Steel Band - Cast Iron endplates, steel fan cover				S
Cast iron frame - cast iron endplates & fan cover	S	S	S	
Cast Iron conduit box	S	S	S	S
Threaded inlet hole in conduit box	S	S	S	S
Neoprene conduit box lid gasket & lead separator gasket	S	S	S	S
Seal endplate to frame joints	S	S	S	S
V-ring shaft seals - DE & ODE	S		S	S
Inpro/Seal VBX bearing isolators - DE & ODE		S		
Hardware - cad plated	S	S	S	S
Motor unfiltered vibration at rated voltage & frequency < 0.15 in/sec velocity	S		S	S
Motor unfiltered vibration at rated voltage & frequency < 0.08 in/sec velocity		S		
Test vibration on DE & ODE and document - ship with motor		S		
Low bearing temperature specs (IEEE 841)		S		
.005" Foot flatness; Shaft runout < NEMA		S		
Sound power level < 90 dBA		S		
Grease inlet fitting - grease fitting				S
Grease inlet with tube extension & grease fitting	S	S	S	
Grease outlet with screw-in plug				S
Grease outlet with tube extension & pressure relief	S	S	S	
Non-metallic external cooling fan	S	S	S	S
Painted with 2-part epoxy primer; dark grey epoxy finish coat	S	S	S	S
ASTM B117-90 96 hour salt spray tests	S	S	S	S
Embossed Stainless steel nameplate with NEMA data	S	S	S	S
2nd stainless steel nameplate with bearing and grease data	S	S	S	
416 Stainless steel material on shaft				S
Complies with IEEE 45 standards for Marine Duty			S	
Warranty	3 Years	5 years	18 Months	18 Months

**Note:** Contact your Baldor District Office for certified data, dimensions and features of a specific motor.

s = standard, o = optional

## TEFC - Severe Duty Stock and Custom HP/Frame Size Capabilities

### Three Phase - Typical Frame Size / Speed - RPM

Hp	3600	1800	1200	900
1	56	56, 143T or 182	56 or 145T	182T
1 1/2	143T	56, 145T or 184	145T or 182T	184T
2	145T	56, 145T or 184	184T	213T
3	145T, 182T or 184	182T or 213	213T	215T
5	184T	184T or 215	215T	254T
7 1/2	184T or 213T	213T	254T	256T
10	215T	215T	256T	284T
15	254T	254T	284T	286T
20	256T	256T	286T	324T
25	284TS	284T	324T	326T
30	286TS	286T	326T	364T
40	324TS	324T	364T	365T
50	326TS	326T	365T	404T
60	365TS	364T	404T	405T
75	365TS	365T	405T	444T
100	405TS	405T	444T	445T
125	444TS	444T	445T	447T
150	447TS or 5007SY	445T	447T	449T or 5007L
200	447TS or 5007SY	447T, 449T or 5007L	449T or 5007L	5007L or 5009L
250	449TS or 5007SY	449T or 5007L	449TY or 5009L	5009L, 5011LY or 5810
300	449TS or 5007SY	449TY or 5007L	449TY, 5009L or 5810	5011LY or 5810
350	449TS or 5007SY	449TY, 5007LY or 5011LY	5009L, 5011LY or 5810	5011LY or 5810
400	449TS or 5007SY	5007L, 5011LY or 5810	5011LY or 5810	5810
450	5007SY	5007L, 5011LY or 5810	5011LY or 5810	5810
500	5009SY	5009L, 5011LY or 5810	5011LY or 5810	5810 or 5812
600	5009SY	5011LY or 5810	5810	5812
700	5009SY	5810	5812	
800		5810		
900		5812		

**NOTE:** Shaded area denotes Stock motors. See Performance Data for voltage and frame availability.

Motors listed with catalog numbers in this brochure are available from stock. Baldor lead times on non-stock motors are 10 working days, providing a spec already exists.

Performance data is subject to change. Drawings shown are for reference only. Please contact Baldor for current performance data or a detailed drawing on the specific motor you require. Data and drawings may be available from our CD-ROM or website at [www.baldor.com](http://www.baldor.com)

### Metric Frame Severe Duty Motors

Baldor Severe Duty motors are available in IEC frames 63 through 400 with base, B5 flange or B14 C-face. Motors can be supplied for 50 or 60 Hz operation. Contact your Baldor District Office for more information.

## IEEE 841 NEMA Premium™ Efficient Motors

Baldor IEEE 841 motors deliver reliable, rugged performance with the industry's highest energy efficiencies. These motors exceed IEEE 841 – 2001 standards for severe duty TEFC induction motors. These motors contain all the standard features of our Chemical Processing motor, plus: Inpro/Seal® bearing isolators at both the drive end and fan end to ensure protection from contaminants; tighter dimensional tolerances for foot flatness and shaft diameter; certified performance and balance tests shipped with each motor; and a 5-year warranty.



### Performance Data: TEFC - Totally Enclosed Fan Cooled, Rigid Base 460 Volts, Three Phase, 1 through 75 Hp

Hp	kW	RPM	Frame	Catalog No.	Amps @ 460 V*		F.L. Torque Lb. Ft.	Efficiency %			Power Factor %			Bearings		"C" Dim.	Conn. Diag. No.
					F.L.	L.R.		1/2	3/4	F.L.	1/2	3/4	F.L.	DE	ODE		
1	0.75	3450	143T	ECP83580T-4	1.4	12.1	1.5	80.5	83.6	84.5	65	77	82	6205	6203	12.75	CD0006
1	0.75	1750	143T	ECP83581T-4	1.4	12.4	3.0	83.8	85.9	85.5	57	69	77	6205	6203	12.75	CD0006
1	0.75	1150	145T	ECP83582T-4	1.8	9.6	4.5	82.3	84.0	82.5	42	55	63	6205	6203	12.75	CD0006
1 1/2	1.1	3450	143T	ECP83583T-4	2.0	20.1	2.3	81.3	84.3	85.5	68	78	83	6205	6203	12.75	CD0006
1 1/2	1.1	1740	145T	ECP83584T-4	2.0	16.8	4.5	86.4	87.6	86.5	61	73	80	6205	6203	12.75	CD0006
1 1/2	1.1	1170	182T	ECP83667T-4	2.6	14.7	6.8	86.0	88.3	87.5	41	53	61	6206	6205	15.93	CD0006
2	1.5	3450	145T	ECP83586T-4	2.5	30.0	3.0	83.8	86.2	86.5	70	80	85	6205	6203	12.75	CD0006
2	1.5	1725	145T	ECP83587T-4	2.7	19.6	6.0	88.1	88.1	86.5	66	77	82	6205	6203	12.75	CD0006
2	1.5	1170	184T	ECP83664T-4	3.5	20.9	9.0	86.7	88.6	88.5	41	52	61	6206	6205	15.93	CD0006
3	2.2	3500	182T	ECP83660T-4	3.4	34.5	4.5	87.5	89.1	88.5	83	89	92	6206	6205	15.93	CD0006
3	2.2	1760	182T	ECP83661T-4	4.0	32.0	9.0	89.1	90.0	89.5	58	71	80	6206	6205	15.93	CD0006
3	2.2	1160	213T	ECP83764T-4	5.0	32.0	13.5	88.3	89.9	89.5	45	57	64	6307	6206	19.32	CD0006
5	3.7	3500	184T	ECP83663T-4	5.7	62.0	7.5	88.2	89.8	89.5	77	86	90	6206	6205	15.93	CD0006
5	3.7	1160	215T	ECP83768T-4	8.0	54.0	22.5	86.7	88.6	89.5	46	58	64	6307	6206	19.32	CD0006
5	3.7	1750	184T	ECP83665T-4	6.5	54.0	15.0	89.7	90.7	90.2	62	74	80	6206	6205	15.93	CD0006
7 1/2	5.6	3525	213T	ECP83769T-4	8.6	75.0	11.2	90.0	91.4	91.0	79	87	90	6307	6206	19.32	CD0006
7 1/2	5.6	1770	213T	ECP83770T-4	9.8	67.0	22.2	90.7	91.9	91.7	56	68	76	6307	6206	19.32	CD0006
7 1/2	5.6	1180	254T	ECP82276T-4	10.7	70.1	33.3	90.6	91.8	91.7	53	65	71	6309	6208	25.50	CD0006
10	7.5	3500	215T	ECP83771T-4	11.2	120	15.0	92.7	92.9	91.7	82	89	92	6307	6206	19.32	CD0006
10	7.5	1760	215T	ECP83774T-4	12.6	83.5	30.0	91.7	92.4	91.7	62	75	81	6307	6206	19.32	CD0006
10	7.5	1180	256T	ECP82332T-4	14.2	93	44.4	90.2	91.6	91.7	55	66	72	6309	6208	25.50	CD0006
15	11.2	3525	254T	ECP82394T-4	17.2	128	22.2	90.8	91.9	91.7	78	86	88	6309	6208	25.50	CD0006
15	11.2	1765	254T	ECP82333T-4	18.5	122.9	44.6	91.9	92.6	92.4	66	77	82	6309	6208	25.50	CD0006
15	11.2	1180	284T	ECP84100T-4	18.7	132	66.7	92.3	92.8	92.4	65	76	81	6311	6309	28.61	CD0006
20	14.9	3540	256T	ECP84106T-4	23.0	201	29.7	91.1	92.3	92.4	74	84	89	6309	6208	25.50	CD0006
20	14.9	1765	256T	ECP82334T-4	24.0	175.0	59.0	92.8	93.1	93.0	69	80	84	6309	6208	25.50	CD0006
20	14.9	1180	286T	ECP84102T-4	25.0	178.0	89.0	92.3	92.9	92.4	65	75	81	6311	6309	28.61	CD0006
25	18.7	3530	284TS	ECP84107T-4	28.0	196	37.0	92.4	93.2	93.0	82	89	91	6311	6309	27.24	CD0006
25	18.7	1770	284T	ECP84103T-4	30.0	188	74.2	92.4	93.6	93.6	72	81	84	6311	6309	28.61	CD0006
25	18.7	1180	324T	ECP84111T-4	32.0	228	112	92.3	93.1	93.0	65	75	80	6312	6311	30.16	CD0006
30	22.4	3530	286TS	ECP84108T-4	33.0	225	44.6	93.0	93.5	93.0	82	88	90	6311	6309	27.24	CD0006
30	22.4	1770	286T	ECP84104T-4	36.0	246	89.0	93.8	94.4	94.1	66	75	83	6311	6309	28.61	CD0006
30	22.4	1180	326T	ECP84117T-4	39.0	285	134	92.4	93.2	93.0	61	72	79	6312	6311	30.16	CD0006
40	30	3540	324TS	ECP84109T-4	45.0	286	59.5	93.9	94.4	93.6	82	88	90	6312	6311	30.50	CD0006
40	30	1775	324T	ECP84110T-4	46.0	320	118	93.9	94.6	94.5	73	81	86	6312	6311	30.16	CD0006
40	30	1185	364T	ECP84308T-4	50.5	355	177	93.3	94.3	94.1	62	73	79	6313	6312	32.84	CD0006
50	37	3540	326TS	ECP84114T-4	54.2	422	74.0	93.8	94.4	94.1	85	90	92	6312	6311	30.50	CD0006
50	37	1775	326T	ECP84115T-4	57.0	392	149	94.4	94.9	94.5	73	82	87	6312	6311	30.16	CD0006
50	37	1185	365T	ECP84312T-4	61.0	409	221	93.8	94.3	94.1	67	77	81	6313	6312	32.84	CD0006
60	45	3560	364TS	ECP84310T-4	67.0	580	88.5	92.6	94.0	94.1	78	86	90	6313	6312	30.13	CD0006
60	45	1780	364T	ECP84314T-4	69.0	447	177	94.7	95.2	95.0	74	82	86	6313	6312	32.84	CD0006
60	45	1185	404T	ECP84403T-4	72.5	455	265	94.0	94.7	94.5	69	78	83	6316	6313	38.03	CD0006
75	56	3565	365TS	ECP84313T-4	83.0	740	111	93.4	94.6	94.5	81	87	90	6313	6312	31.13	CD0006
75	56	1780	365T	ECP84316T-4	86.5	649	222	94.9	95.5	95.4	73	81	85	6313	6312	32.84	CD0006
75	56	1185	405T	ECP84404T-4	88.0	579	331	94.3	95.1	95.0	72	80	84	6316	6313	38.03	CD0006

**NOTE:** See page 26 for Layout drawing. See page 37 for Connection Diagrams.

Efficiencies shown are nominal.

Data subject to change without notice. Contact Baldor for certified data.

Shaded ratings are cast iron frames.

**IEEE 841 NEMA Premium™ Efficient Motors**



**Performance Data: TEFC - Totally Enclosed Fan Cooled, Rigid Base  
460 Volts, Three Phase, 100 through 250 Hp**

Hp	kW	RPM	Frame	Catalog No.	Amps		F.L. Torque Lb. Ft.	Efficiency %			Power Factor %			Bearings		"C" Dim.	Conn. Diag. No.
					F.L.	L.R.		1/2	3/4	F.L.	1/2	3/4	F.L.	DE	ODE		
100	74.6	1780	405T	ECP84400T-4	109	790	295	95.2	95.6	95.4	83	89	90	6316	6313	38.03	CD0006
100	74.6	3560	405TS	ECP84402T-4	110	777	148	93.9	94.9	95.0	81	87	89	6313	6313	35.75	CD0006
100	74.6	1180	444T	ECP84409T-4	120	738	445	94.3	95.1	95.4	72	80	82	6319	6314	44.25	CD0006
125	93.2	3570	444TS	ECP84412T-4	136	974	184	94.6	95.5	95.4	81	88	90	6314	6314	40.50	CD0006
125	93.2	1780	444T	ECP84410T-4	139	960	369	94.7	95.4	95.4	78	85	88	6319	6314	44.25	CD0006
125	93.2	1190	445T	ECP84411T-4	150	1007	552	94.6	95.4	95.4	68	78	82	6319	6314	44.25	CD0006
150	112	3570	445TS	ECP84413T-4	165	1210	221	94.8	95.7	95.8	81	87	80	6314	6314	40.50	CD0006
150	112	1785	445T	ECP84406T-4	173	1070	442	95.6	96.0	95.8	71	80	85	6319	6314	44.24	CD0006
150	112	1190	447T	ECP844156T-4	173	1123	662	95.5	96.0	95.8	75	82	85	6319	6314	47.74	CD0006
200	149.2	3570	447TS	ECP84416T-4	220	1565	294	94.8	95.7	95.8	82	87	89	6314	6314	49.00	CD0006
200	149.2	1785	447T	ECP84407T-4	224	1595	588	95.8	96.3	96.2	77	84	87	6319	6314	47.74	CD0006
200	149.2	1180	449T	ECP844206T-4	242	1647	890	94.5	95.2	95.8	70	80	81	6319	6314	52.65	CD0006
250	186.5	3570	449TS	ECP844252T-4	272	2165	370	95.6	96.2	95.8	81	87	90	6314	6314	49.00	CD0006
250	186.5	1785	449T	ECP84408T-4	275	1867	735	95.9	96.2	95.8	83	88	90	6319	6314	52.65	CD0006
250	186.5	1180	449T	ECP844256T-4	294	1690	1105	95.0	95.6	95.8	73	80	83	6319	6314	54.37	CD0006

**NOTE:** See page 26 for Layout drawing. See page 37 for Connection Diagrams.

Shaded ratings are cast iron frames.

**Performance Data: TEFC - Totally Enclosed Fan Cooled, Rigid Base  
575 Volts, Three Phase, 1 through 250 Hp**

Hp	kW	RPM	Frame	Catalog No.	Amps		F.L. Torque Lb. Ft.	Efficiency %			Power Factor %			Bearings		"C" Dim.	Conn. Diag. No.
					F.L.	L.R.		1/2	3/4	F.L.	1/2	3/4	F.L.	DE	ODE		
1	0.75	1750	143T	ECP83581T-5	1.1	9.8	3.0	83.8	85.9	85.5	57	69	77	6205	6203	12.75	CD0006
1 1/2	1.1	1740	145T	ECP83584T-5	1.6	12.5	4.5	86.6	87.4	86.5	65	76	82	6205	6203	12.75	CD0006
2	1.5	1725	145T	ECP83587T-5	2.2	15.7	6.0	88.1	88.1	86.5	66	77	82	6205	6203	12.75	CD0006
3	2.2	1760	182T	ECP83661T-5	3.2	26.0	9.0	89.1	90.0	89.5	58	71	77	6206	6205	15.93	CD0006
5	3.7	1750	184T	ECP83665T-5	5.2	44	15.0	89.7	90.7	90.2	62	74	80	6206	6205	15.93	CD0006
7 1/2	5.6	1770	213T	ECP83770T-5	8	53.6	22.2	90.7	91.9	91.7	56	68	76	6307	6206	19.32	CD0006
10	7.5	1760	215T	ECP83774T-5	10	66.8	30.0	91.7	92.4	91.7	62	75	81	6307	6206	19.32	CD0006
15	11.2	1765	254T	ECP82333T-5	14.8	99	44.5	91.3	92.5	92.4	67	78	82	6309	6208	25.50	CD0006
20	14.9	1765	256T	ECP82334T-5	19.2	140	59	92.8	93.1	93.0	69	80	84	6309	6208	25.50	CD0006
25	18.7	1770	284T	ECP84103T-5	23.9	188	74.2	92.4	93.6	93.6	72	81	84	6311	6309	28.61	CD0006
30	22.4	1770	286T	ECP84104T-5	29	197	89	93.8	94.4	94.1	66	75	83	6311	6309	28.61	CD0006
40	30	1775	324T	ECP84110T-5	36.8	259	118	93.9	94.6	94.5	70	79	86	6312	6311	30.16	CD0006
50	37	1775	326T	ECP84115T-5	45.6	318	149	94.4	94.9	94.5	81	80	87	6312	6311	30.16	CD0006
60	45	1780	364T	ECP84314T-5	55	375	177	93.6	94.8	95.0	73	81	86	6313	6312	32.84	CD0006
75	56	1780	365T	ECP84316T-5	68	519	222	94.9	95.5	95.4	73	81	85	6313	6312	32.84	CD0006
100	74.6	1780	405T	ECP84400T-5	87	634	295	95.2	95.6	95.4	84	89	90	6316	6313	38.03	CD0006
125	93.2	1780	444T	ECP84410T-5	112	768	369	94.7	95.4	95.4	78	85	88	6319	6314	44.24	CD0006
150	111.9	1785	445T	ECP84406T-5	141	892	442	95.6	96.0	95.8	70	79	85	6319	6314	44.24	CD0006
200	149.2	1785	447T	ECP84407T-5	179	1340	587	94.9	95.8	96.2	75	83	87	6319	6314	47.74	CD0006
250	186.5	1785	449T	ECP84408T-5	220	1496	735	95.6	95.8	95.8	83	88	90	6319	6314	52.65	CD0006

**NOTE:** See page 26 for Layout drawing. See page 37 for Connection Diagrams.

Shaded ratings are cast iron frames.

## IEEE 841 NEMA Premium™ Efficient Motors

Performance Data: TEFC - Totally Enclosed Fan Cooled, C-Face, Rigid Base, 460 Volts, Three Phase, 1 through 75 Hp

Hp	kW	RPM	Frame	Catalog No.	Amps		F.L. Torque Lb. Ft.	Efficiency %			Power Factor %			Bearings		"C" Dim.	Conn. Diag. No.
					F.L.	L.R.		1/2	3/4	F.L.	1/2	3/4	F.L.	DE	ODE		
1	0.75	3450	143TC	CECP83580T-4	1.4	12.1	1.5	80.5	83.6	84.5	65	77	82	6205	6203	13.25	CD0006
1	0.75	1750	143TC	CECP83581T-4	1.4	14.0	3.0	83.8	86.2	86.5	54	72	78	6205	6203	13.25	CD0006
1 1/2	1.1	3450	143TC	CECP83583T-4	2.0	20.1	2.3	81.3	84.3	85.5	68	78	83	6205	6203	13.25	CD0006
1 1/2	1.1	1740	145TC	CECP83584T-4	2.0	16.8	4.5	86.4	87.6	86.5	61	73	80	6205	6203	13.25	CD0006
2	1.5	3450	145TC	CECP83586T-4	2.5	30.0	3.0	83.8	86.2	86.5	70	80	85	6205	6203	13.25	CD0006
2	1.5	1725	145TC	CECP83587T-4	2.7	19.6	6.0	88.1	88.1	86.5	66	77	82	6205	6203	13.25	CD0006
3	2.2	3500	182TC	CECP83660T-4	3.4	34.5	4.5	87.5	89.1	88.5	83	89	92	6206	6205	16.69	CD0006
3	2.2	1760	182TC	CECP83661T-4	4.0	32.0	9.0	89.1	90.0	89.5	58	71	80	6206	6205	16.69	CD0006
5	3.7	3500	184TC	CECP83663T-4	5.7	62.0	7.5	88.2	89.8	89.5	77	86	90	6206	6205	16.69	CD0006
5	3.7	1750	184TC	CECP83665T-4	6.5	54.0	15.0	89.7	90.7	90.2	62	74	80	6206	6205	16.69	CD0006
7 1/2	5.6	3525	213TC	CECP83769T-4	8.6	75.0	11.2	90.0	91.4	91.0	79	87	90	6307	6206	20.06	CD0006
7 1/2	5.6	1770	213TC	CECP83770T-4	9.5	77.0	22.2	90.0	91.6	91.7	63	75	80	6307	6206	20.06	CD0006
10	7.5	3500	215TC	CECP83771T-4	11.2	120	15.0	92.7	92.9	91.0	82	89	92	6307	6206	20.06	CD0006
10	7.5	1760	215TC	CECP83774T-4	12.6	89.5	30.0	91.2	92.4	91.7	62	75	81	6307	6206	20.06	CD0006
15	11.2	3525	254TC	CECP82394T-4	17.2	128	22.2	90.8	91.9	91.7	78	86	88	6309	6208	26	CD0006
15	11.2	1765	254TC	CECP82333T-4	18.5	122.9	44.6	91.9	92.6	92.4	66	77	82	6309	6208	26	CD0006
20	14.9	3540	256TC	CECP84106T-4	23	201	29.7	91.1	92.3	92.4	74	84	89	6309	6208	26	CD0006
20	14.9	1765	256TC	CECP82334T-4	24.0	175.0	59.0	92.8	93.1	93.0	69	80	84	6309	6208	26	CD0006
25	18.7	3530	284TSC	CECP84107T-4	28.0	196	37.2	92.4	93.2	93.0	82	89	91	6311	6309	27.24	CD0006
25	18.7	1790	284TC	CECP84103T-4	30.0	189.6	74.2	92.4	93.6	93.6	72	81	84	6311	6309	28.61	CD0006
30	22.4	3530	284TSC	CECP84108T-4	33	237	44.6	93.0	93.5	93.0	82	88	90	6311	6309	27.24	CD0006
30	22.4	1770	286TC	CECP84104T-4	36.0	246	89.0	93.8	94.4	94.1	66	75	83	6311	6309	28.61	CD0006
40	30	3540	324TSC	CECP84109T-4	45.0	286	59.5	93.9	94.4	93.6	82	88	90	6312	6311	30.50	CD0006
40	30	1775	324TC	CECP84110T-4	46.0	320	118	93.9	94.6	94.5	73	81	86	6312	6311	30.16	CD0006
50	37	3540	326TSC	CECP84114T-4	54.2	422	74.0	93.8	94.4	94.1	85	90	92	6312	6311	30.50	CD0006
50	37	1775	326TC	CECP84115T-4	57.0	392	149	94.4	94.9	94.5	73	82	87	6312	6311	30.16	CD0006
60	45	3560	364TSC	CECP84310T-4	67.0	580	88.5	92.6	94.0	94.1	78	86	90	6313	6312	31.13	CD0006
60	45	1780	364TC	CECP84314T-4	69.0	441	177	94.7	95.2	95.0	74	82	86	6313	6312	32.84	CD0006
75	56	3565	365TSC	CECP84313T-4	83.0	740	111	93.4	94.6	94.5	81	87	90	6313	6312	31.13	CD0006
75	56	1780	365TC	CECP84316T-4	86.5	649	222	94.9	95.5	95.4	73	81	85	6313	6312	32.84	CD0006

**NOTE:** See page 27 for Layout drawing. See page 37 for Connection Diagrams.

Efficiencies shown are nominal.

Data subject to change without notice. Contact Baldor for certified data.

Shaded ratings are cast iron frames.

# Chemical Processing NEMA Premium™ Efficient Motors

Designed to meet the demanding application requirements typically found in severe duty processing environments, Baldor Super-E Chemical Processing motors feature cast-iron frames, endplates and conduit boxes, regreasable ball bearings, oversized rotatable cast iron conduit box, Forsheda® shaft seal, Class F insulation, 2-part zinc-chromate primer inside and outside the motor with a corrosion resistant epoxy finish. These motors are tropicalized.



## Performance Data: TEFC - Totally Enclosed Fan Cooled, Rigid Base 230/460 and 460 Volts only, Three Phase, 1 through 200 Hp

Hp	kW	RPM	Frame	Catalog No. ①	Amps		F.L. Torque Lb. Ft.	Efficiency %			Power Factor %			Bearings		"C" Dim.	Conn. Diag. No.
					F.L.	L.R.		1/2	3/4	F.L.	1/2	3/4	F.L.	DE	ODE		
1	0.746	1750	143T	ECP3581T-4	1.38	14	3	83.8	86.2	86.6	58	72	79	6205	6203	12.75	CD0006
1.5	1.119	1740	145T	ECP3584T-4	2	16.8	4.5	86.4	87.6	87.4	61	73	80	6205	6203	12.75	CD0006
2	1.492	1725	145T	ECP3587T-4	2.6	19.6	6	88.1	88.1	86.8	66	77	82	6205	6203	12.75	CD0006
3	2.238	3500	182T	ECP3660T-4	3.4	34.5	4.5	87.5	89.1	89.3	83	89	92	6206	6205	15.93	CD0006
3	2.238	1760	182T	ECP3661T-4	4.1	32	9	89.1	90	89.7	58	71	77	6206	6205	15.93	CD0006
3	2.238	1160	213T	ECP3764T-4	4.9	32	13.5	88.3	89.9	90.1	45	57	64	6307	6206	19.32	CD0006
5	3.73	3500	184T	ECP3663T-4	5.8	62	7.5	88.2	89.8	90	77	86	90	6206	6205	15.93	CD0006
5	3.73	1750	184T	ECP3665T-4	6.5	54	15	89.7	90.7	90.4	62	74	80	6206	6205	15.93	CD0006
5	3.73	1160	215T	ECP3768T-4	8	54	22.5	86.7	88.6	88.8	46	58	66	6307	6206	19.32	CD0006
7.5	5.595	3525	213T	ECP3769T-4	8.6	75	11.2	90	91.4	91.4	79	87	90	6307	6206	19.32	CD0006
7.5	5.595	1770	213T	ECP3770T-4	9.8	67	22.2	90.7	91.9	92	56	68	75	6307	6206	19.32	CD0006
7.5	5.595	1180	254T	ECP2276T-4	10.72	70.1	33.3	90.6	91.8	91.9	53	65	71	6309	6208	23.25	CD0006
10	7.46	3500	215T	ECP3771T-4	11.1	120	15	92.7	92.9	92.3	82	89	92	6307	6206	19.32	CD0006
10	7.46	1760	256T	ECP3774T-4	12.6	83.5	30	91.7	92.4	91.8	62	75	81	6307	6206	19.32	CD0006
10	7.46	1180	256T	ECP2332T-4	14.2	93	44.4	90.2	91.6	91.7	55	66	72	6309	6208	23.25	CD0006
15	11.19	3525	254T	ECP2394T-4	17.2	128	22.2	90.8	91.9	91.9	78	86	88	6309	6208	23.25	CD0006
15	11.19	1765	254T	ECP2333T-4	18.54	122.9	44.6	91.9	92.6	92.4	66	77	82	6309	6208	23.25	CD0006
15	11.19	1180	284T	ECP4100T-4	18.7	132	66.7	92.3	92.8	92.6	65	76	81	6311	6309	27.56	CD0006
20	14.92	3540	256T	ECP4106T-4	22.9	201	29.7	91.1	92.3	92.4	74	84	89	6309	6208	23.25	CD0006
20	14.92	1765	256T	ECP2334T-4	23.7	175	59	92.8	93.1	93	69	80	84	6309	6208	23.25	CD0006
20	14.92	1180	286T	ECP4102T-4	25	178	89	92.3	92.9	92.8	65	75	81	6311	6309	27.56	CD0006
25	18.65	3530	284TS	ECP4107T-4	27.5	236	37.2	93	93.5	93.2	82	89	91	6311	6309	24.66	CD0006
25	18.65	1770	284T	ECP4103T-4	29.63	187.6	74.2	92.4	93.6	93.6	72	81	84	6311	6309	27.56	CD0006
25	18.65	1180	324T	ECP4111T-4	32.2	228	112	92.3	93.1	93	65	75	80	6312	6311	30.16	CD0006
30	22.38	3520	286TS	ECP4108T-4	32.9	281	44.7	93.2	93.5	93.1	83	89	92	6311	6309	24.66	CD0006
30	22.38	1770	286T	ECP4104T-4	36	246	89	93.8	94.4	94.3	66	75	83	6311	6309	27.56	CD0006
30	22.38	1180	326T	ECP4117T-4	39.3	285	134	92.4	93.2	93	61	72	78	6312	6311	30.16	CD0006
40	29.84	3540	324TS	ECP4109T-4	44.9	286	59.5	93.9	94.4	94.1	82	88	90	6312	6311	28.66	CD0006
40	29.84	1775	324T	ECP4110T-4	46.9	320	118	93.9	94.6	94.6	73	81	84	6312	6311	30.16	CD0006
40	29.84	1185	364T	ECP4308T-4	50.7	355	177	93.3	94.3	94.3	62	73	79	6313	6312	32.84	CD0006
50	37.3	3540	326TS	ECP4114T-4	54.2	422	74	93.8	94.4	94.3	85	90	92	6312	6311	28.66	CD0006
50	37.3	1775	326T	ECP4115T-4	58.3	392	149	94.4	94.9	94.7	73	82	85	6312	6311	30.16	CD0006
50	37.3	1185	365T	ECP4312T-4	61.2	409	221	93.8	94.3	94.2	67	77	81	6313	6312	32.84	CD0006
60	44.76	3565	364TS	ECP4310T-4	66.4	580	88.5	92.6	94	94.5	78	86	90	6313	6312	30.72	CD0006
60	44.76	1780	364T	ECP4314T-4	69	447	177	94.7	95.2	95	74	82	86	6313	6312	32.84	CD0006
60	44.76	1185	404T	ECP4403T-4	72.5	455	265	94	94.7	94.5	69	78	83	6316	6313	38.03	CD0006
75	55.95	3565	365TS	ECP4313T-4	82.8	740	111	93.4	94.6	95	81	87	90	6313	6312	30.72	CD0006
75	55.95	1780	365T	ECP4316T-4	86.5	649	222	94.9	95.5	95.5	73	81	85	6313	6312	32.84	CD0006
75	55.95	1185	405T	ECP4404T-4	87.8	579	331	94.3	95.1	95	72	80	84	6316	6313	38.03	CD0006
100	74.6	3560	405TS	ECP4402T-4	109.4	810	150	94.4	95.2	95.3	81	87	89	6313	6313	35.06	CD0006
100	74.6	1780	405T	ECP4400T-4	108.6	790	295	95.2	95.6	95.4	83	89	90	6316	6313	38.03	CD0006
100	74.6	1180	444T	ECP4409T-4	120	738	445	94.3	95.1	95.4	72	80	84	6319	6314	44.24	CD0006
125	93.25	3570	444TS	ECP4412T-4	136	974	184	94.6	95.5	95.4	81	88	90	6313	6313	40.50	CD0006
125	93.25	1780	444T	ECP4410T-4	139	960	368	95.1	95.5	95.4	80	86	88	6319	6314	44.24	CD0006
125	93.25	1190	445T	ECP4411T-4	150	1007	552	94.6	95.4	95.4	68	78	82	6319	6314	44.24	CD0006
150	111.9	3570	445TS	ECP4413T-4	164	1144	221	94.6	95.4	95.4	82	88	90	6313	6313	40.50	CD0006
150	111.9	1785	445T	ECP4406T-4	173	1070	442	95.6	96.0	95.8	71	80	85	6319	6314	44.24	CD0006
150	111.9	1190	445T	ECP44156T-4	173	1123	662	95.5	96.0	95.8	75	82	85	6319	6314	47.74	CD0006
200	149.2	3570	447TS	ECP4416T-4	220	1565	294	94.8	95.7	95.8	82	87	89	6313	6313	43.99	CD0006
200	149.2	1785	447T	ECP4407T-4	224	1595	588	95.8	96.3	96.2	77	84	87	6319	6314	47.74	CD0006
200	149.2	1180	449T	ECP44206T-4	242	1647	890	94.5	95.2	95.8	70	80	81	6319	6314	52.65	CD0006

**NOTE:** \* For 230 volt amps, double 460 volt amps. See page 24 for Layout drawing.

Shaded ratings are cast iron frames.

① 1-75 Hp, 3500 and 1760 rpm available as 230/460. Catalog number is the same as shown except omit "-4".

See page 31 for Connection Diagrams. Efficiencies shown are nominal. Data subject to change without notice. Contact Baldor for certified data.

## Chemical Processing NEMA Premium™ Efficient Motors

**Performance Data: TEFC - Totally Enclosed Fan Cooled,  
Rigid Base, 460 Volts, Three Phase, 250 through 400 Hp**

Hp	kW	RPM	Frame	Catalog No.	Amps		F.L. Torque Lb. Ft.	Efficiency %			Power Factor %			Bearings		"C" Dim.	Conn. Diag. No.
					F.L.	L.R.		1/2	3/4	F.L.	1/2	3/4	F.L.	DE	ODE		
250	186.5	3545	449TS	ECP44252T-4	262	1920	370	95.0	95.3	95.4	92	93	93	6314	6314	48.90	CD0006
250	186.5	1780	449T	ECP4408T-4	276	1720	740	93.9	94.9	95.8	79	86	89	6319	6314	52.65	CD0006
250	186.5	1180	449TY	ECP44256T-4	294	1690	1105	95.0	95.6	95.8	73	80	83	6319	6314	54.37	CD0006
300	223.8	3560	449TS	ECP44302T-4	320	2204	444	95.1	95.4	95.4	92	93	93	6314	6314	48.90	CD0006
300	223.8	1785	449TY	ECP44304T-4	333	2500	883	95.1	95.8	95.8	81	86	88	6319	6314	54.35	CD0006
300	223.8	1185	449T	ECP44306T-4	355	2370	1328	94.3	95.0	95.0	71	80	83	6319	6314	54.35	CD0006
350	261	3560	449TS	ECP44352T-4	372	2550	518	95.3	95.6	95.4	92	93	93	6314	6314	48.90	CD0006
350	261	1785	449TY	ECP44354T-4	388	2750	1032	95.3	95.6	95.8	83	87	89	6319	6314	54.35	CD0006
350	261	1190	5011L	ECP50356L-4	386	2759	1545	95.8	96.2	95.8	80	86	88	6324	6222	72.05	CD0006
400	298.4	3545	449TS	ECP44402T-4	422	3155	593	95.4	95.8	95.8	89	92	93	6314	6314	48.90	CD0006
400	298.4	1780	449TY	ECP44404T-4	440	3150	1179	95.6	95.9	95.8	83	88	89	6319	6314	54.35	CD0006

**Stock Ratings with Roller Bearings**

150	112	1190	447T	ECP44156TR-4	173	1123	662	95.5	96.0	95.8	75	82	85	NU319	6314	47.74	CD0006
200	268	1785	447T	ECP4407TR-4	224	1595	588	95.8	96.3	96.2	77	84	87	NU319	6314	47.74	CD0006
200	268	1180	449TY	ECP44206TR-4	242	1647	890	94.5	95.2	95.8	70	80	81	N319	6314	54.35	CD0006
250	186.5	1780	449TY	ECP4408TR-4	276	1720	740	93.9	94.9	95.8	79	86	89	N319	6314	54.35	CD0006
250	186.5	1180	449TY	ECP44256TR-4	294	1690	1105	95.0	95.6	95.8	73	80	83	N319	6314	54.35	CD0006
300	223.8	1785	449TY	ECP44304TR-4	333	2500	883	95.1	95.8	95.8	81	86	88	N319	6314	54.35	CD0006
300	223.8	1185	449TY	ECP44306TR-4	355	2370	1328	94.3	95.0	95.0	71	80	83	N319	6314	54.35	CD0006
350	261	1785	449TY	ECP44354TR-4	388	2750	1032	95.3	95.6	95.8	83	87	89	N319	6314	54.35	CD0006
400	298.4	1780	449TY	ECP44404TR-4	440	3150	1179	95.6	95.9	95.8	83	88	89	N319	6314	54.35	CD0006

## Performance Data: TEFC - Totally Enclosed Fan Cooled, Rigid Base 230/460 Volts, Three Phase, 1 through 75 Hp

Hp	kW	RPM	Frame	Catalog No.	Amps		F.L. Torque Lb. Ft.	Efficiency %			Power Factor %			Bearings		"C" Dim.	Conn. Diag. No.
					F.L.	L.R.		1/2	3/4	F.L.	1/2	3/4	F.L.	DE	ODE		
1	0.75	1750	143T	ECP3581T	1.38	14	3	83.8	86.2	86.6	58	72	79	6205	6203	12.75	CD0005
1	0.75	1150	145T	ECP3582T	1.8	9.6	4.5	82.3	84	83.5	42	55	63	6205	6203	12.75	CD0005
1.5	1.1	1740	145T	ECP3584T	2	16.8	4.5	86.4	87.6	87.4	61	73	80	6205	6203	12.75	CD0005
1.5	1.1	1170	182T	ECP3667T	2.6	14.7	6.8	86	88.3	88.7	41	53	61	6206	6205	15.93	CD0005
2	1.5	1725	145T	ECP3587T	2.59	20.8	6	87.3	88.2	87.5	65	77	82	6205	6203	12.75	CD0005
2	1.5	1170	184T	ECP3664T	3.5	20.9	9	86.7	88.6	88.9	41	52	61	6206	6205	15.93	CD0005
3	2.2	1760	182T	ECP3661T	4.1	32	9	89.1	90	89.7	58	71	77	6206	6205	15.93	CD0005
3	2.2	1160	213T	ECP3764T	4.9	32	13.5	88.3	89.9	90.1	45	57	64	6307	6206	19.32	CD0005
5	3.7	1750	184T	ECP3665T	6.5	54	15	89.7	90.7	90.4	62	74	80	6206	6205	15.93	CD0005
5	3.7	1160	215T	ECP3768T	7.7	54	22.7	89.2	90.2	90	48	60	68	6307	6206	19.32	CD0005
7.5	5.6	1770	213T	ECP3770T	9.8	67	22.2	90.7	91.9	92	56	68	75	6307	6206	19.32	CD0005
7.5	5.6	1180	254T	ECP2276T	10.72	70.1	33.3	90.6	91.8	91.9	53	65	71	6309	6208	23.25	CD0005
10	7.5	1760	215T	ECP3774T	12.6	83.5	30	91.7	92.4	91.8	62	75	81	6307	6206	19.32	CD0005
10	7.5	1180	256T	ECP2332T	14.2	93	44.4	90.2	91.6	91.7	55	66	72	6309	6208	23.25	CD0180
15	11.2	1765	254T	ECP2333T	18.54	122.9	44.6	91.9	92.6	92.4	66	77	82	6309	6208	23.25	CD0005
15	11.2	1180	284T	ECP4100T	18.7	132	66.7	92.3	92.8	92.6	65	76	81	6311	6309	27.56	CD0180
20	14.9	1765	256T	ECP2334T	23.7	175	59	92.8	93.1	93	69	80	84	6309	6208	23.25	CD0005
20	14.9	1175	286T	ECP4102T	25.08	173.4	89.3	92.2	92.7	92.4	67	77	81	6311	6309	27.56	CD0005
25	18.7	1770	284T	ECP4103T	29.63	187.6	74.2	92.4	93.6	93.6	72	81	84	6312	6311	27.56	CD0005
25	18.7	1180	324T	ECP4111T	32.2	228	112	92.3	93.1	93	65	75	80	6311	6309	30.16	CD0005
30	22.4	1770	286T	ECP4104T	36	246	89	93.8	94.4	94.3	66	75	83	6312	6311	27.56	CD0005
30	22.4	1180	326T	ECP4117T	39.3	285	134	92.4	93.2	93	61	72	78	6312	6311	30.16	CD0005
40	29.8	1775	324T	ECP4110T	46.9	320	118	93.9	94.6	94.6	73	81	84	6312	6311	30.16	CD0180
40	29.8	1185	364T	ECP4308T	49.33	327	177	93.7	94.3	94.1	67	77	81	6313	6312	32.84	CD0005
50	37.3	1775	326T	ECP4115T	58.3	392	149	94.4	94.9	94.7	73	82	85	6312	6311	30.16	CD0180
50	37.3	1185	365T	ECP4312T	61.2	409	221	93.8	94.3	94.2	67	77	81	6313	6312	32.84	CD0005
60	44.8	1780	364T	ECP4314T	69	447	177	94.7	95.2	95	74	82	86	6313	6312	32.84	CD0180
60	44.8	1185	404T	ECP4403T	72.3	452	265	93.8	94.7	94.5	69	78	82	6316	6313	38.03	CD0180
75	56.0	1780	365T	ECP4316T	87.3	610	221	94.7	95.4	95.5	73	81	84	6313	6312	32.84	CD0005
75	56.0	1185	405T	ECP4404T	87.8	579	331	94.3	95.1	95	72	80	84	6316	6313	38.03	CD0180

**NOTE:** See page 24 and 25 for Layout drawing. See page 37 for Connection Diagrams.

Shaded ratings are cast iron frames.

## Chemical Processing NEMA Premium™ Efficient Motors

Performance Data: TEFC - Totally Enclosed Fan Cooled, Rigid Base,  
575 Volts, Three Phase, 1 through 200 Hp

Hp	kW	RPM	Frame	Catalog No.	Amps		F.L. Torque Lb. Ft.	Efficiency %			Power Factor %			Bearings		"C" Dim.	Conn. Diag. No.
					F.L.	L.R.		1/2	3/4	F.L.	1/2	3/4	F.L.	DE	ODE		
1	0.75	1750	143T	ECP3581T-5	1.1	11.0	3.0	84.0	85.8	85.5	56	70	78	6205	6203	12.75	CD0006
1 1/2	1.1	1740	145T	ECP3584T-5	1.6	12.5	4.5	86.6	87.4	86.5	65	76	82	6205	6203	12.75	CD0006
2	1.5	1740	145T	ECP3587T-5	2.2	19.2	6.0	85.2	87.0	86.5	62	74	80	6205	6203	12.75	CD0006
3	2.2	1760	182T	ECP3661T-5	3.2	26.0	9.0	89.1	90.0	89.5	58	71	80	6206	6205	15.93	CD0006
3	2.2	1160	213T	ECP3764T-5	4.0	26.0	13.5	88.3	89.9	89.5	45	57	64	6307	6206	19.32	CD0006
5	3.7	1750	184T	ECP3665T-5	5.2	44.0	15.0	89.7	90.7	90.2	62	74	80	6206	6205	15.93	CD0006
5	3.7	1160	215T	ECP3768T-5	6.4	43.2	22.7	89.2	90.2	89.5	48	60	64	6307	6206	19.32	CD0006
7 1/2	5.6	1770	213T	ECP3770T-5	8.0	61.6	22.2	90.0	91.6	91.7	63	75	82	6307	6206	19.32	CD0006
7 1/2	5.6	1180	254T	ECP2276T-5	8.4	58.0	33.4	90.3	91.6	91.7	54	66	73	6309	6208	23.25	CD0006
10	7.5	1760	215T	ECP3774T-5	10.0	72.8	30.0	91.0	91.9	91.7	67	78	83	6307	6206	19.32	CD0006
10	7.5	1180	256T	ECP2332T-5	11.2	73.0	44.5	90.7	91.7	91.7	54	66	73	6309	6208	23.25	CD0006
15	11.2	1765	254T	ECP2333T-5	14.8	99.0	44.5	91.3	92.5	92.4	67	78	82	6309	6208	23.25	CD0006
15	11.2	1180	284T	ECP4100T-5	15.0	106	66.7	92.3	92.8	92.4	64	75	81	6311	6309	27.56	CD0006
20	14.9	1765	256T	ECP2334T-5	19.0	138	59.0	92.0	93.0	93.0	67	77	85	6309	6208	23.25	CD0006
20	14.9	1175	286T	ECP4102T-5	20.0	136	89.3	92.2	92.7	92.4	66	77	81	6311	6309	27.56	CD0006
25	18.7	1770	284T	ECP4103T-5	23.9	187.6	74.2	92.4	93.6	93.6	72	81	84	6311	6309	27.56	CD0006
25	18.7	1180	324T	ECP4111T-5	25.3	217	111	92.5	93.2	93.0	66	76	80	6312	6311	30.16	CD0006
30	22.4	1770	286T	ECP4104T-5	29.0	197	89.0	93.8	94.4	94.1	66	75	83	6311	6309	27.56	CD0006
40	30	1775	324T	ECP4110T-5	36.8	259	118	93.9	94.6	94.5	70	79	86	6312	6311	30.16	CD0006
50	37	1775	326T	ECP4115T-5	45.6	318	149	94.4	94.9	94.5	81	80	87	6312	6311	30.16	CD0006
60	45	1780	364T	ECP4314T-5	55.0	362	177	94.7	95.2	95.0	71	81	86	6313	6312	32.84	CD0006
75	56	1780	365T	ECP4316T-5	68.0	488	221	94.7	95.4	95.4	73	81	87	6313	6312	32.84	CD0006
100	74.6	1780	405T	ECP4400T-5	89.0	601	294	94.1	95.1	95.4	77	85	88	6316	6313	38.03	CD0006
125	93.25	1780	444T	ECP4410T-5	112	768	368	95.1	95.5	95.4	80	86	88	6319	6314	44.24	CD0006
150	111.9	1785	445T	ECP4406T-5	141	892	442	95.6	96.0	95.8	70	79	85	6319	6314	44.24	CD0006
200	149.2	1785	445T	ECP4407T-5	179	1340	587	94.9	95.8	96.2	75	83	87	6319	6314	47.74	CD0006

NOTE: See page 24 for Layout drawing. See page 37 for Connection Diagrams.

Shaded ratings are cast iron frames.



## Performance Data: TEFC - Totally Enclosed Fan Cooled, Rigid Base, 2300/4160 Volts, Three Phase, 200 through 500 Hp

Hp	kW	RPM	Frame	Catalog No.	Amps		F.L. Torque Lb. Ft.	Efficiency %			Power Factor %			Bearings		"C" Dim.	Conn. Diag. No.
					F.L.	L.R.		1/2	3/4	F.L.	1/2	3/4	F.L.	DE	ODE		
200	150	3560	449TS	ECP44202T-2341	25	159	295	93.5	94.2	94.1	87	90	91	6314	6314	49.00	CD0022
200	150	1780	449T	ECP44204T-2341	26	164	590	92.9	93.9	93.8	79	85	87	6319	6314	52.65	CD0022
250	187	3580	5007S	ECP50252S-2341	31	407	367	94.4	95.1	95.0	86	90	91	6314	6314	53.66	CD0022
250	187	1790	5007L	ECP50254L-2341	31	214	734	92.7	94.3	95.0	81	87	89	6322	6222	56.62	CD0022
250	187	1185	5009L	ECP50256L-2341	33	214	1104	93.3	94.2	94.5	74	82	86	6324	6222	62.56	CD0022
300	224	3578	5007S	ECP50302S-2341	36	260	440	94.7	95.3	95.4	85	90	91	6314	6314	53.66	CD0022
300	224	1790	5009L	ECP50304L-2341	37	239	880	93.4	94.9	95.4	83	88	90	6322	6222	62.50	CD0022
300	224	1185	5011L	ECP50306L-2341	40	240	1325	93.7	94.5	94.1	76	84	85	6324	6222	70.56	CD0022
350	261	1790	5011L	ECP50354L-2341	43	232	514	93.7	94.9	95.4	82	88	89	6322	6222	70.50	CD0022
350	261	1185	5011L	ECP50356L-2341	46	300	1545	93.9	94.8	95.0	75	83	85	6324	6222	70.56	CD0022
400	298	3580	5007S	ECP50402S-2341	48	332	587	94.8	95.5	95.4	86	91	91	6314	6314	53.66	CD0022
400	298	1790	5011L	ECP50404L-2341	50	323	1174	93.8	95.0	95.4	82	87	89	6322	6222	70.50	CD0022
400	298	1185	5011L	ECP50406L-2341	52	369	1765	93.9	94.8	95.0	74	82	86	6324	6222	70.50	CD0022
450	336	1790	5011L	ECP50454L-2341	56	331	1320	94.1	95.2	95.4	83	88	89	6322	6222	70.50	CD0022
450	336	1190	5011L	ECP50456L-2341	68	283	1985	93.7	95.0	95.4	60	70	75	6324	6222	70.56	CD0022
500	373	3580	5009S	ECP50502S-2341	60	401	734	95.4	96.0	95.8	87	90	92	6314	6314	58.80	CD0022
500	373	1790	5011L	ECP50504L-2341	60	386	1467	96.1	96.2	95.8	85	89	90	6322	6222	70.50	CD0022
500	373	1190	5011L	ECP50506L-2341	72	314	2204	93.9	95.2	95.4	59	69	75	6324	6222	70.56	CD0022

NOTE: See pages 24-25 for Layout drawing. See page 37 for Connection Diagrams.

Shaded ratings are cast iron frames.

Efficiencies shown are nominal.

Data subject to change without notice. Contact Baldor for certified data.

## Chemical Processing NEMA Premium™ Efficient Motors

### Performance Data: TEFC - Totally Enclosed Fan Cooled, C-Face, No Base 460 Volts, Three Phase, 1 through 10 Hp

Hp	kW	RPM	Frame	Catalog No.	Amps		F.L. Torque Lb. Ft.	Efficiency %			Power Factor %			Bearings		"C" Dim.	Conn. Diag. No.
					F.L.	L.R.		1/2	3/4	F.L.	1/2	3/4	F.L.	DE	ODE		
1	0.75	3450	56C	VECP3580-4	1.4	12.1	1.5	80.5	83.6	84.5	65	77	82	6205	6203	12.69	CD0006
1	0.75	1750	56C	VECP3581-4	1.4	14	3	83.8	86.2	86.5	58	72	78	6205	6203	12.69	CD0006
1	0.75	1750	143TC	VECP3681T-4	1.4	14	3	84	85.8	85.5	56	70	78	6205	6203	12.75	CD0006
1 1/2	1.1	3450	143TC	VECP3583T-4	2	20.1	2.3	81.3	84.3	85.5	68	78	83	6205	6203	12.75	CD0006
1 1/2	1.1	1740	145TC	VECP3584T-4	2	15.6	4.5	86.6	87.4	86.5	65	76	82	6205	6203	12.75	CD0006
2	1.5	3450	145TC	VECP3586T-4	2.5	30	3	83.8	86.2	86.5	70	80	85	6205	6203	12.75	CD0006
2	1.5	1740	145TC	VECP3587T-4	2.7	24	6	85.2	87	86.5	62	74	80	6205	6203	12.75	CD0006
3	2.2	3500	182TC	VECP3660T-4	3.4	34.5	4.5	87.5	89.1	88.5	83	89	92	6206	6205	15.93	CD0006
3	2.2	1760	182TC	VECP3661T-4	4	32	9	89.1	90	89.5	58	71	80	6206	6205	15.93	CD0006
5	3.7	3500	184TC	VECP3663T-4	5.5	62.3	7.6	89.4	90	89.5	86	94	96	6206	6205	15.93	CD0006
5	3.7	1750	184TC	VECP3665T-4	6.5	54	15	89.7	90.7	90.2	62	74	80	6206	6205	15.93	CD0006
7 1/2	5.6	3500	213TC	VECP3769T-4	8.6	75	11.2	90	91.4	91	79	87	90	6307	6206	19.32	CD0006
7 1/2	5.6	1770	213TC	VECP3770T-4	9.5	77	22.2	90	91.6	91.7	63	75	80	6307	6206	19.32	CD0006
10	7.5	3525	215TC	VECP3771T-4	11.9	112	15	90.2	91.2	91	74	84	93	6307	6206	19.32	CD0006
10	7.5	1760	215TC	VECP3774T-4	12.5	91	30	91	91.9	91.7	67	78	83	6307	6206	19.32	CD0006

### Performance Data: TEFC - Totally Enclosed Fan Cooled, C-Face, No Base 230/460 Volts, Three Phase, 1 through 25 Hp

Hp	kW	RPM	Frame	Catalog No.	Amps		F.L. Torque Lb. Ft.	Efficiency %			Power Factor %			Bearings		"C" Dim.	Conn. Diag. No.
					F.L.	L.R.		1/2	3/4	F.L.	1/2	3/4	F.L.	DE	ODE		
1	0.75	1750	56C	VECP3581	1.4	14	3	83.8	86.2	86.5	58	72	78	6205	6203	12.69	CD0005
1	0.75	1750	143TC	VECP3581T	1.4	14	3	84	85.8	85.5	56	70	78	6205	6203	12.75	CD0005
1	0.75	1150	145TC	VECP3582T	1.8	9.6	4.5	82.3	84	82.5	42	55	63	6205	6203	13.93	CD0005
1 1/2	1.1	1740	145TC	VECP3584T	2	15.6	4.5	86.6	87.4	86.5	65	76	82	6205	6203	12.75	CD0005
1 1/2	1.1	1170	182TC	VECP3667T	2.6	14.7	6.8	86	88.3	87.5	41	53	61	6206	6205	16.98	CD0005
2	1.5	1740	145TC	VECP3587T	2.7	24	6	85.2	87	86.5	62	74	80	6205	6203	12.75	CD0005
2	1.5	1160	814TC	VECP3664T	3.5	20.9	9	86.7	88.6	88.5	41	52	61	6206	6205	16.98	CD0005
3	2.2	1760	182TC	VECP3661T	4	32	9	89.1	90	89.5	58	71	80	6206	6205	15.93	CD0005
3	2.2	1160	213TC	VECP3764T	5	32	13.5	88.3	89.9	89.5	45	57	64	6307	6206	19.32	CD0005
5	3.7	1750	184TC	VECP3665T	6.5	54	15	89.7	90.7	90.2	62	74	80	6206	6205	15.93	CD0005
5	3.7	1160	215TC	VECP3768T	8	54	22.5	86.7	88.6	89.5	46	58	64	6307	6206	19.32	CD0005
7 1/2	5.6	1770	213TC	VECP3770T	9.5	77	22.2	90	91.6	91.7	63	75	80	6307	6206	19.32	CD0005
7 1/2	5.6	1180	254TC	VECP2276T	10.7	70.1	33.3	90.6	91.8	91.7	53	65	71	6309	6208	23.25	CD0005
10	7.5	1760	215TC	VECP3774T	12.5	91	30	91	91.9	91.7	67	78	83	6307	6206	19.32	CD0005
10	7.5	1180	256TC	VECP2332T	14.2	93	44.4	90.2	91.6	91.7	55	60	72	6309	6208	25.88	CD0180
15	11.2	1765	254TC	VECP2333T	18.5	122.9	44.6	91.9	92.6	92.4	66	77	82	6309	6208	23.25	CD0005
15	11.2	1180	284TC	VECP4100T	18.7	132	66.7	92.3	92.89	92.4	65	76	81	6311	6309	27.56	CD0180
20	14.9	1765	256TC	VECP2334T	24	175.1	59.5	92.6	93.3	93	70	79	84	6309	6208	23.25	CD0005
20	14.9	1175	826TC	VECP4102T	25	173.4	89.3	92.2	92.7	92.4	67	77	81	6311	6309	27.56	CD0005
25	18.6	1780	284TC	VECP4103T	30.5	188	74	91	92.7	93.6	70	79	82	6311	6309	27.56	CD0005
25	18.6	1180	324TC	VECP4111T	32	217	111	92.5	93.2	93	66	76	80	6312	6311	30.16	CD0005

**NOTE:** See page 25 for Layout drawing. See page 37 for Connection Diagrams.  
Efficiencies shown are nominal.  
Data subject to change without notice. Contact Baldor for certified data.

Shaded ratings are cast iron frames.

## Chemical Processing Standard Efficient Motors

Baldor Standard Efficient Chemical Processing motors meet EAct efficiency levels. Mechanical features include corrosion resistant epoxy finish, regreasable ball bearings, oversized, rotatable cast iron conduit box, Forsheda® shaft seal and stainless steel nameplate and corrosion resistant hardware. Electrical features include 1.15 Service Factor, Class F insulation and moisture resistant copper windings. These motors are tropicalized. "CP" catalog numbers indicate Chemical Processing motors available in frames 143T through 405T.



"M" catalog number motors in frames 449T and up share many of the same design characteristics as "CP" motors.

### Performance Data: TEFC – Totally Enclosed Fan Cooled, Rigid Base, 460 Volts, Three Phase, 1 through 40 Hp

Hp	kW	RPM	Frame	Catalog No.	Amps		F.L. Torque Lb. Ft.	Efficiency %			Power Factor %			Bearings		"C" Dim.	Conn. Diag. No.
					F.L.	L.R.		1/2	3/4	F.L.	1/2	3/4	F.L.	DE	ODE		
1	0.75	3450	143T	CP3580T-4	1.5	10	1.5	72	76.6	77	65	77	83	6205	6203	12.75	CD0006
1	0.75	1740	143T	CP3581T-4	1.4	9.7	3	81.2	82.9	82.5	63	74	80	6205	6203	12.75	CD0006
1	0.75	1140	145T	CP3582T-4	1.7	9	4.5	79.6	81.4	80	52	65	72	6205	6203	12.75	CD0006
1 1/2	1.1	3450	143T	CP3583T-4	2.1	18	2.2	80.1	82.6	82.5	76	85	85	6205	6203	12.75	CD0006
1 1/2	1.1	1740	145T	CP3584T-4	2.1	16	4.5	82.7	84.3	84	60	72	79	6205	6203	12.75	CD0006
1 1/2	1.1	1160	182T	CP3667T-4	2.6	13.3	6.7	83.9	86.1	85.5	41	53	63	6206	6205	15.93	CD0006
2	1.5	3450	145T	CP3586T-4	2.6	24.3	3	81.2	83.8	84	73	80	88	6205	6203	12.75	CD0006
2	1.5	1740	145T	CP3587T-4	2.8	21	6	83.8	85.2	84	61	73	79	6205	6203	12.75	CD0006
2	1.5	1160	184T	CP3664T-4	3.5	19.5	9	83.7	86.2	86.5	42	54	63	6206	6205	15.93	CD0006
3	2.2	3450	182T	CP3660T-4	3.5	35.5	4.5	84.9	86.7	85.5	82	90	93	6206	6205	15.93	CD0006
3	2.2	1740	182T	CP3661T-4	4.1	32.4	8.9	86.1	87.8	87.5	59	71	78	6206	6205	15.93	CD0006
3	2.2	1160	213T	CP3764T-4	4.9	30.7	13.5	85.4	87.6	87.5	45	57	65	6307	6206	19.32	CD0006
5	3.7	3500	184T	CP3663T-4	6	56	7.6	87.8	88.4	87.5	83	89	92	6206	6205	15.93	CD0006
5	3.7	1750	184T	CP3665T-4	6.7	51.2	15	87.3	88.4	87.5	63	74	80	6206	6205	15.93	CD0006
5	3.7	1160	215T	CP3768T-4	8.1	55.9	22.6	85.5	87.4	87.5	46	58	65	6307	6206	19.32	CD0006
7 1/2	5.6	3450	213T	CP3769T-4	9	74.5	11.3	88.2	89.6	88.5	79	85	88	6307	6206	19.32	CD0006
7 1/2	5.6	1750	213T	CP3770T-4	10.2	72.6	22.2	87.7	89.7	89.5	57	69	76	6307	6206	19.32	CD0006
7 1/2	5.6	1160	254T	CP2276T-4	12.5	85	33.8	88.7	90.1	89.5	43	56	63	6309	6206	23.7	CD0006
10	7.5	3500	215T	CP3771T-4	11.5	84	15	90.6	90.8	89.5	83	88	91	6307	6307	19.32	CD0006
10	7.5	1760	215T	CP3774T-4	14.2	100	29.9	87.8	89.6	89.5	54	67	73	6307	6206	19.32	CD0006
10	7.5	1160	256T	CP2332T-4	14.4	86.1	44.6	88.6	89.9	89.5	56	67	73	6309	6206	23.25	CD0006
15	11.2	3500	215T	CP3773T-4	17	152	22.6	91.6	91.9	90.2	85	90	91	6307	6208	19.32	CD0006
15	11.2	1760	254T	CP2394T-4	17	152	22.6	91.6	91.9	90.2	85	90	91	6309	6206	21.94	CD0006
15	11.2	1175	254T	CP2333T-4	19.2	129	45	91	92	91	65	75	80	6309	6307	21.94	CD0006
15	11.2	3450	284T	CP4100T-4	19.7	129.8	66.8	88.7	90.2	90.2	64	74	79	6311	6307	26.03	CD0006
20	14.9	3450	256T	CP4106T-4	23	227	30	91.6	91.9	90.2	79	86	90	6309	6309	23.7	CD0006
20	14.9	1760	256T	CP2334T-4	24	160	60	90.6	91.5	91	72	81	86	6309	6307	23.25	CD0006
20	14.9	1175	286T	CP4102T-4	26	165.8	89.2	89.4	90.4	90.2	65	75	80	6311	6208	27.56	CD0006
25	18.6	3450	284TS	CP4107T-4	29	180.4	37.2	89.5	91.1	91	82	88	90	6311	6309	24.66	CD0006
25	18.6	1760	284T	CP4103T-4	31	184	74	91.3	92.3	92.4	69	79	82	6311	6309	26.03	CD0006
25	18.6	1175	324T	CP4111T-4	31	212	111	91.4	92.1	91.7	72	80	83	6312	6309	30.19	CD0006
30	22.4	3520	284TS	CP4108T-4	35	280	44.8	90.7	91.4	91	84	90	92	6311	6311	24.66	CD0006
30	22.4	1765	286T	CP4104T-4	37	215	89	91.6	92.5	92.4	69	79	83	6311	6309	26.03	CD0006
30	22.4	1175	326T	CP4117T-4	37	231	134	91.8	92.3	91.7	73	80	83	6312	6311	30.27	CD0006
40	30	3530	324TS	CP4109T-4	45	285	59.5	90.9	91.8	91.7	84	88	90	6312	6311	28.69	CD0006
40	30	1775	324T	CP4110T-4	48	304	119	92.4	93.2	93	72	81	85	6312	6309	30.27	CD0006

**NOTE:** \* For 230 volt amps, double 460 volt amps.

See page 24 for Layout drawing. See page 37 for Connection Diagrams.

Efficiencies shown are nominal.

Data subject to change without notice. Contact Baldor for certified data.

Shaded ratings are cast iron frames.

## Performance Data: TEFC - Totally Enclosed Fan Cooled, Rigid Base 460 Volts, Three Phase, 50 through 500 Hp

Hp	kW	RPM	Frame	Catalog No.	Amps		F.L. Torque Lb. Ft.	Efficiency %			Power Factor %			Bearings		"C" Dim.	Conn. Diag. No.
					F.L.	L.R.		1/2	3/4	F.L.	1/2	3/4	F.L.	DE	ODE		
50	37	1770	326T	CP4115T-4	59	372	148	92.4	93.2	93.0	74	82	85	6312	6311	30.27	CD0006
50	37	1180	365T	CP4312T	61	421	222	92.3	93.1	93.0	70	79	83	6313	6312	32.84	CD0005
60	45	1775	364T	CP4314T-4	71	430	177	92.8	93.7	93.6	75	83	85	6313	6312	32.84	CD0006
60	45	1185	405T	CP4403T	70	479	266	93.2	94.0	93.6	75	83	86	6316	6313	38.03	CD0005
75	56	1775	365T	CP4316T-4	86	566	222	93.4	94.3	94.1	77	85	87	6313	6312	32.84	CD0006
75	56	1185	405T	CP4404T	88	621	332	93.2	93.9	93.6	73	81	85	6316	6313	38.03	CD0180
100	75	1780	405T	CP4400T-4	115	786	295	93.9	94.7	94.5	75	83	86	6316	6313	38.03	CD0006
200	150	1185	449T	M44206T-4	236	1337	885	94.8	95.3	95.0	73	81	83	6319	6314	52.65	CD0382
250	187	3560	449TS	M44252T-4	268	1944	368	94.0	94.3	94.5	92	93	93	6314	6314	48.90	CD0382
250	187	1185	449TY	M44256T-4	304	1890	1103	94.8	95.3	95.0	71	79	83	6319	6314	54.37	CD0382
300	224	3560	449TS	M44302T-4	320	2302	442	94.6	94.8	95.0	92	93	93	6314	6314	48.90	CD0382
300	224	1785	449T	M44304T-4	328	2566	883	95.8	96.0	95.8	81	86	88	6319	6314	52.65	CD1071
300	224	1185	449TY	M44306T-4	372	2364	1330	95.0	95.4	95.4	68	77	80	6319	6314	54.37	CD0382
350	261	3560	449TS	M44352T-4	372	2325	441	94.4	94.8	95.0	89	91	92	6314	6314	48.90	CD0382
350	261	1785	449T	M44354T-4	388	2871	1032	94.5	95.7	95.8	81	88	89	6319	6314	52.65	CD1071
350	261	1190	5009L	M50356L-4	386	2759	1545	95.8	96.2	95.8	80	86	88	6322	6222	59.56	CD0382
400	298	3560	449TS	M44402T-4	422	3155	592	95.4	95.8	95.8	89	92	93	6314	6314	48.90	CD0382
400	298	1785	449T	M44404T-4	440	3134	1180	95.8	96.1	95.8	82	88	89	6319	6314	52.65	CD1071
500	373	3575	5009S	M50502S-4	530	3389	735	96.2	96.4	96.2	89	92	92	6314	6314	59.66	CD0382
500	373	1790	5009L	M50504L-4	556	3903	1464	94.8	95.6	95.8	81	87	89	6322	6222	62.56	CD1435

NOTE: See page 24 - 25 for Layout drawing. See page 37-38 for Connection Diagrams.

Shaded ratings are cast iron frames.

## Performance Data: TEFC - Totally Enclosed Fan Cooled, Rigid Base, 230/460 Volts, Three Phase, 1 through 40 Hp

Hp	kW	RPM	Frame	Catalog No.	Amps		F.L. Torque Lb. Ft.	Efficiency %			Power Factor %			Bearings		"C" Dim.	Conn. Diag. No.
					F.L.	L.R.		1/2	3/4	F.L.	1/2	3/4	F.L.	DE	ODE		
1	0.75	1740	143T	CP3581T	1.4	9.7	3	81.2	82.9	82.5	63	74	80	6205	6203	12.75	CD0005
1	0.75	1140	145T	CP3582T	1.7	9	4.5	79.6	81.4	80	52	65	72	6205	6203	12.75	CD0005
1 1/2	1.1	1740	145T	CP3584T	2.1	16	4.5	82.7	84.3	84	60	72	79	6205	6203	12.75	CD0005
1 1/2	1.1	1160	182T	CP3667T	2.6	13.3	6.7	83.9	86.1	85.5	41	53	63	6206	6205	15.93	CD0005
2	1.5	1740	145T	CP3587T	2.8	21	6	83.8	85.2	84	61	73	79	6205	6203	12.75	CD0005
2	1.5	1160	184T	CP3664T	3.5	19.5	9	83.7	86.2	86.5	42	54	63	6206	6205	15.93	CD0005
3	2.2	1750	182T	CP3661T	4.1	32.4	8.9	86.1	87.8	87.5	59	71	78	6206	6205	15.93	CD0005
3	2.2	1160	213T	CP3764T	4.9	30.7	13.5	85.4	87.6	87.5	45	57	65	6307	6206	19.32	CD0005
5	3.7	1750	184T	CP3665T	6.7	51.2	15	87.3	88.4	87.5	63	74	80	6206	6205	15.93	CD0005
5	3.7	1160	215T	CP3768T	8.1	55.9	22.6	85.5	87.4	87.5	46	58	65	6307	6206	19.32	CD0005
7 1/2	5.6	1760	213T	CP3770T	10.2	72.6	22.2	87.7	89.7	89.5	57	69	76	6307	6206	19.32	CD0005
7 1/2	5.6	1160	254T	CP2276T	12.5	85	33.8	88.7	90.1	89.5	43	56	63	6309	6206	23.7	CD0005
10	7.5	1760	215T	CP3774T	14.2	100	29.9	87.8	89.6	89.5	54	67	73	6307	6206	19.32	CD0005
10	7.5	1175	256T	CP2332T	14.4	86.1	44.6	88.6	89.9	89.5	56	67	73	6309	6206	23.25	CD0005
15	11.2	1760	254T	CP2333T	19.2	129	45	91	92	91	65	75	80	6309	6307	21.94	CD0005
15	11.2	1175	284T	CP4100T	19.7	129.8	66.8	88.7	90.2	90.2	64	74	79	6311	6307	26.03	CD0005
20	14.9	1760	256T	CP2334T	24	160	60	90.6	91.5	91	72	81	86	6309	6307	23.25	CD0180
20	14.9	1175	286T	CP4102T	26	165.8	89.2	89.4	90.4	90.2	65	75	80	6311	6208	27.56	CD0005
25	18.6	1770	284T	CP4103T	31	184	74	91.3	92.3	92.4	69	79	82	6311	6309	26.03	CD0005
25	18.6	1175	324T	CP4111T	31	212	111	91.4	92.1	91.7	72	80	83	6312	6309	30.19	CD0005
30	22.4	1765	286T	CP4104T	37	215	89	91.6	92.5	92.4	69	79	83	6311	6309	26.03	CD0005
30	22.4	1175	326T	CP4117T	37	231	134	91.8	92.3	91.7	73	80	83	6312	6311	30.27	CD0005
40	30	1775	324T	CP4110T	48	304	119	92.4	93.2	93	72	81	85	6312	6309	30.27	CD0005

NOTE: \* For 230 volt amps, double 460 volt amps.

See page 24 for Layout drawing. See page 37 for Connection Diagrams.

Efficiencies shown are nominal.

Data subject to change without notice. Contact Baldor for certified data.

Shaded ratings are cast iron frames.

**Performance Data: TEFC - Totally Enclosed Fan Cooled, C-Face, No Base  
460 Volts, Three Phase, 1 through 10 Hp**

Hp	kW	RPM	Frame	Catalog No.	Amps		F.L. Torque Lb. Ft.	Efficiency %			Power Factor %			Bearings		"C" Dim.	Conn. Diag. No.
					F.L.	L.R.		1/2	3/4	F.L.	1/2	3/4	F.L.	DE	ODE		
1	0.75	3450	56C	VCP3580-4	1.6	9.5	1.5	63	71	74	62	71	79	6205	6203	12.69	CD0006
1	0.75	1725	56C	VCP3581-4	1.7	11.6	3	73.4	77.2	77	49	63	74	6205	6203	12.69	CD0006
1	0.75	1725	143TC	VCP3581T-4	1.7	11.6	3	73.4	77.2	77	49	63	74	6205	6203	12.75	CD0006
1 1/2	1.1	3450	143TC	VCP3583T-4	2.3	15.7	2.3	67.9	73.4	75.5	57	69	76	6205	6203	12.75	CD0006
1 1/2	1.1	1725	145TC	VCP3584T-4	2.5	17.3	4.5	72	75.5	78.5	50	66	72	6205	6203	12.75	CD0006
2	1.5	3450	145TC	VCP3586T-4	2.7	18	3	76.9	78.5	78.5	81	87	93	6205	6203	12.75	CD0006
2	1.5	1725	145TC	VCP3587T-4	3.1	21	6	80.5	82.3	82.5	56	69	77	6205	6203	12.75	CD0006
3	2.2	3450	182TC	VCP3660T-4	3.9	33	4.5	78.3	81.2	80	77	85	87	6206	6205	16.69	CD0006
3	2.2	1725	182TC	VCP3661T-4	4.3	30	9	82.6	84.5	84	59	72	75	6206	6205	16.69	CD0006
5	3.7	3450	184TC	VCP3663T-4	6	47	7.5	85.8	86.5	85.5	88	93	93	6206	6205	16.69	CD0006
5	3.7	1725	184TC	VCP3665T-4	6.6	53	15	85.8	85.8	85.5	62	74	80	6206	6205	16.69	CD0006
7 1/2	5.6	3450	213TC	VCP3769T-4	9.1	70	11.3	80.7	83.1	84	86	91	91	6307	6206	20.06	CD0006
7 1/2	5.6	1750	213TC	VCP3770T-4	10	80	22.5	84.9	87	87.5	63	75	75	6307	6206	20.06	CD0006
10	7.5	3450	215TC	VCP3771T-4	12	106	15	82.8	85.2	85.5	86	90	90	6307	6206	20.06	CD0006
10	7.5	1725	215TC	VCP3774T-4	13.5	112	30	85.9	87.6	87.5	63	74	74	6307	6206	20.06	CD0006

**NOTE:** \* For 230 volt amps, double 460 volt amps. Shaded ratings are cast iron frames.  
See page 25 for Layout drawing. See page 37 for Connection Diagrams.  
Efficiencies shown are nominal.  
Data subject to change without notice. Contact Baldor for certified data.

**Performance Data: TEFC - Totally Enclosed Fan Cooled, C-Face, No Base  
230/460 Volts, Three Phase, 1 through 25 Hp**

Hp	kW	RPM	Frame	Catalog No.	Amps		F.L. Torque Lb. Ft.	Efficiency %			Power Factor %			Bearings		"C" Dim.	Conn. Diag. No.
					F.L.	L.R.		1/2	3/4	F.L.	1/2	3/4	F.L.	DE	ODE		
1	0.75	1725	56C	VCP3581	1.7	11.6	3	73.4	77.2	77	49	63	74	6205	6203	12.69	CD0005
1	0.75	1725	143TC	VCP3581T	1.7	11.6	3	73.4	77.2	77	49	63	74	6205	6203	13.92	CD0005
1	0.75	1140	145TC	VCP3582T	1.7	9	4.5	79.6	81.4	80	52	65	72	6205	6203	13.92	CD0005
1 1/2	1.1	1725	145TC	VCP3584T	2.5	17.3	4.5	72	75.5	78.5	50	66	72	6205	6205	13.92	CD0005
1 1/2	1.1	1160	182TC	VCP3667T	2.6	13.3	6.7	83.9	86.1	85.5	41	53	63	6206	6203	16.98	CD0005
2	1.5	1725	145TC	VCP3587T	3.1	21	6	80.5	82.3	82.5	56	69	77	6205	6205	13.92	CD0005
2	1.5	1160	184TC	VCP3664T	3.5	19.5	9	83.7	86.2	86.5	42	54	63	6206	6205	16.98	CD0005
3	2.2	1725	182TC	VCP3661T	4.3	30	9	82.6	84.5	84	59	72	75	6206	6206	16.98	CD0005
3	2.2	1160	213TC	VCP3764T	4.9	30.7	13.5	85.4	87.6	87.5	45	57	65	6307	6205	21.11	CD0005
5	3.7	1725	184TC	VCP3665T	6.6	53	15	85.8	85.8	85.5	62	74	80	6206	6206	16.98	CD0005
5	3.7	1160	215TC	VCP3768T	8.1	55.9	22.6	85.5	87.4	87.5	46	58	65	6307	6206	21.11	CD0005
7 1/2	5.6	1750	213TC	VCP3770T	10	80	22.5	84.9	87	87.5	63	75	82	6307	6307	21.11	CD0005
7 1/2	5.6	1160	254TC	VCP2276T	12.5	85	33.8	88.7	90.1	89.5	43	56	63	6309	6307	25.88	CD0005
10	7.5	1725	215TC	VCP3774T	13.5	112	30	85.9	87.6	87.5	63	74	77	6307	6206	21.11	CD0005
10	7.5	1175	256TC	VCP2332T	14.4	86.1	44.6	88.6	89.9	89.5	56	67	73	6309	6208	25.88	CD0005
15	11.2	1760	254TC	VCP2333T	19.2	129	45	91	92	91	65	75	80	6309	6307	25.88	CD0005
15	11.2	1175	284TC	VCP4100T	19.7	129.8	66.8	88.7	90.2	90.2	64	74	79	6311	6309	25.85	CD0005
20	14.9	1760	256TC	VCP2334T	24	160	60	90.6	91.5	91	72	81	86	6309	6208	25.88	CD0180
20	14.9	1175	286TC	VCP4102T	26	165.8	89.2	89.4	90.4	90.2	65	75	80	6311	6309	30.31	CD0005
25	18.6	1770	284TC	VCP4103T	31	184	74	91.3	92.34	92.4	69	79	82	6311	6309	25.85	CD0005
25	18.6	1175	324TC	VCP4111T	31	212	111	91.4	92.1	91.7	72	80	83	6312	6311	33.03	CD0005

**NOTE:** \* For 230 volt amps, double 460 volt amps. Shaded ratings are cast iron frames.  
See page 25 for Layout drawing. See page 37 for Connection Diagrams.  
Efficiencies shown are nominal.  
Data subject to change without notice. Contact Baldor for certified data.



## Dirty Duty™ Motors

Baldor Dirty Duty™ motors are designed with a 416 stainless steel shaft for applications requiring additional protection from corrosive environments. All ratings allow for a 50°C ambient at a 1.0 Service Factor, and meet weatherproof requirements for IEEE 45 below-deck marine duty.



### Performance Data: TEFC – Totally Enclosed Fan Cooled, Rigid Base, 230/460 Volts, Three Phase, 1/2 through 20 Hp

Hp	kW	RPM	Frame	Catalog No.	Amps		F.L. Torque Lb. Ft.	Efficiency %			Power Factor %			Bearings		"C" Dim.	Conn. Diag. No.
					F.L.	L.R.		1/2	3/4	F.L.	1/2	3/4	F.L.	DE	ODE		
1/2	.37	1725	56	M8001	1	6.5	1.5	66.4	72.5	74.0	43	55	63	6203	6203	11.35	CD0005
3/4	.55	1725	56	M8002	1.5	10	2.25	69.7	74.7	75.5	42	55	60	6203	6203	11.35	CD0005
1	.75	1725	56	M8003	1.7	13	3	75.5	78.3	78.5	47	60	71	6203	6203	12.85	CD0005
1	.75	1740	143T	M8003T	1.4	10.5	3	81.4	83.8	82.5	59	72	80	6205	6203	12.75	CD0005
1 1/2	1.1	1740	145T	M8004T	2.1	20	4.5	86.4	87.7	84.0	57	71	79	6205	6203	12.75	CD0005
2	1.5	1740	145T	M8005T	2.8	22.7	6	83.2	85.2	84.0	57	70	79	6205	6203	12.75	CD0005
3	2.2	1750	182T	M8006T	4.1	32.4	8.9	86.1	87.8	87.5	59	71	78	6206	6205	15.93	CD0005
5	3.7	1750	184T	M8007T	6.7	51.2	15	87.3	88.4	87.5	63	74	80	6206	6205	15.93	CD0005
7 1/2	5.6	1760	213T	M8008T	10.2	72.6	22.2	87.7	89.7	89.5	57	69	76	6307	6206	19.32	CD0005
10	7.5	1760	215T	M8009T	14.2	100	29.9	87.8	89.6	89.5	54	67	73	6307	6206	19.32	CD0005
15	11.2	1760	254T	M8010T	19.2	129	45	91.0	92.0	91.0	65	75	80	6309	6307	21.94	CD0005
20	19.9	1760	256T	M8014T	24	160	60	90.6	91.5	91.0	72	81	86	6309	6208	23.25	CD0005

**NOTE:** See page 24 and 28 for Layout drawing. See page 37 for Connection Diagrams.

Shaded ratings are cast iron frames.

### Performance Data: TEFC – Totally Enclosed Fan Cooled, Rigid Base and C-Face- No Drip Cover, 230/460 Volts, Three Phase, 1/2 through 10 Hp

Hp	kW	RPM	Frame	Catalog No.	Amps		F.L. Torque Lb. Ft.	Efficiency %			Power Factor %			Bearings		"C" Dim.	Conn. Diag. No.
					F.L.	L.R.		1/2	3/4	F.L.	1/2	3/4	F.L.	DE	ODE		
1/2	.37	1725	56C	VM8001	1	6.5	1.5	66.4	72.5	74.0	43	55	63	6203	6203	11.35	CD0005
3/4	.55	1725	56C	VM8002	1.5	10	2.25	69.7	74.7	75.5	42	55	60	6203	6203	11.35	CD0005
1	.75	3450	56C	VM8012	1.8	11	1.5	72.1	76.8	75.5	53	68	71	6203	6203	11.35	CD0005
1	.75	1725	56C	VM8003	1.7	13	3	75.5	78.3	78.5	47	60	71	6203	6203	12.85	CD0005
1	.75	1725	143TC	VM8003T	1.7	11.6	3	73.4	77.2	77.0	49	63	74	6205	6203	12.75	CD0005
1 1/2	1.1	3450	143TC	VM8015T	2.3	15.7	2.3	67.9	73.4	75.5	57	69	76	6205	6203	12.75	CD0005
1 1/2	1.1	1725	56C	VM8004	2.5	17	4.5	73.6	77.1	78.5	50	63	72	6205	6203	12.24	CD0005
1 1/2	1.1	1725	145TC	VM8004T	2.5	17.3	4.5	72.0	75.5	78.5	50	66	72	6205	6203	12.75	CD0005
2	1.5	3450	145TC	VM8016T	2.7	18	3	76.9	78.5	78.5	81	87	93	6205	6203	12.75	CD0005
2	1.5	1725	145TC	VM8005T	3.1	21	6	80.5	82.3	82.5	56	69	77	6205	6203	12.75	CD0005
3	2.2	1725	182TC	VM8006T	4.3	30	9	82.6	84.5	84.0	59	72	75	6206	6205	16.69	CD0005
5	3.7	1725	184TC	VM8007T	6.6	53	15	85.8	85.8	85.5	62	74	80	6206	6205	16.69	CD0005
7 1/2	5.6	1750	213TC	VM8008T	10	80	22.5	84.9	87.0	87.5	63	75	82	6307	6206	20.06	CD0005
10	7.5	1750	215TC	VM8024T	13.5	112	30	85.9	87.6	87.5	63	74	77	6307	6206	20.16	CD0005

**NOTE:** See page 25 and 28 for Layout drawing. See page 37 for Connection Diagrams. Efficiencies shown are nominal. Data subject to change without notice. Contact Baldor for certified data.

Shaded ratings are cast iron frames.



## Dirty Duty™ Washdown Motors

Baldor Washdown Duty Motor features proprietary bonded surface coating, stainless steel shaft extension, non-contact rotating labyrinth shaft seal, threaded drain ports, stainless steel plugs, gasketed and sealed conduit box, FDA approved surface coating. Weatherproof per IEEE45 and USCG259 marine duty (below deck duty only).



### Performance Data: TEFC – Totally Enclosed Fan Cooled, 208-230/460 Volts, Three Phase, 1/2 through 10 Hp, C-Face with & without Rigid Base

Hp	kW	RPM	Frame	Catalog No.	Amps		F.L. Torque Lb. Ft.	Efficiency %			Power Factor %			Bearings		"C" Dim.	Conn. Diag. No.
					F.L.	L.R.		1/2	3/4	F.L.	1/2	3/4	F.L.	DE	ODE		
<b>C-Face with Base</b>																	
1/2	.37	1725	56C	CWAM3538	.8	6.25	1.5	72.4	76.2	75.5	64	76	83	6205	6203	11.05	CD0005
3/4	.55	1725	56C	CWAM3542	1.1	8.5	2.3	77.9	79.9	80	55	71	81	6205	6203	11.05	CD0005
1	.75	1725	56C	CWAM3546	1.6	11.3	3.0	75.4	79.3	81.5	58	71	74	6205	6203	12.05	CD0005
1	.75	1725	143TC	CWAM3546T	1.6	11.3	3.0	75.4	79.3	81.5	58	71	74	6205	6203	12.12	CD0005
1 1/2	1.1	1725	145TC	CWAM3554T	2.1	18.3	4.5	78	81.7	82.5	65	72	82	6205	6203	13.00	CD0005
2	1.5	1740	145TC	CWAM3558T	2.8	21	6.0	83.8	85.2	84	61	73	79	6205	6203	13.35	CD0005
3	2.2	1750	182TC	CWAM3611T	4.1	32.4	8.9	86.1	87.8	87.5	59	71	78	6206	6205	16.60	CD0005
5	3.7	1750	184TC	CWAM3615T	6.6	52	15.1	87	88.2	87.5	60	72	79	6206	6205	16.60	CD0005
7 1/2	5.6	1760	213TC	CWAM3710T	10.2	72.6	22.2	87.7	89.7	89.5	57	69	76	6307	6206	18.63	CD0005
10	7.5	1760	215TC	CWAM3714T	14.2	100	29.9	87.8	89.6	89.5	54	67	73	6307	6206	19.76	CD0005
<b>C-Face less Base</b>																	
1/2	.37	1725	56C	VWAM3538	.8	6.25	1.5	72.4	76.2	75.5	64	76	83	6205	6203	11.05	CD0005
3/4	.55	1725	56C	VWAM3542	1.1	8.5	2.3	77.9	79.9	80	55	71	81	6205	6203	11.05	CD0005
1	.75	1725	56C	VWAM3546	1.6	11.3	3	75.4	79.3	81.5	58	71	74	6205	6203	12.05	CD0005
1	.75	1725	143TC	VWAM3546T	1.6	11.3	3	75.4	79.3	81.5	58	71	74	6205	6203	12.12	CD0005
1 1/2	1.1	1725	56C	VWAM3554	2.1	18.3	4.5	78	81.7	82.5	65	72	82	6205	6203	12.93	CD0005
1 1/2	1.1	1725	145TC	VWAM3554T	2.1	18.3	4.5	78	81.7	82.5	65	72	82	6205	6203	13.00	CD0005
2	1.5	1725	56C	VWAM3558	2.8	22	6	82.2	83.7	82.5	59	72	77	6205	6203	13.28	CD0005
2	1.5	1725	145TC	VWAM3558T	2.8	22	6	82.2	83.7	82.5	59	72	77	6205	6203	13.35	CD0005
3	2.2	1725	182TC	VWAM3611T	4.1	35	9	81	83	84	63	75	82	6206	6203	16.60	CD0005
5	3.7	1725	184TC	VWAM3615T	6.6	55	15	85.9	86.1	85.5	69	80	80	6206	6205	16.60	CD0005
7 1/2	5.6	1725	213TC	VWAM3710T	10.2	72.6	22.2	87.7	89.7	89.5	57	69	76	6307	6206	18.63	CD0005
10	7.5	1725	215TC	VWAM3714T	14.2	100	30	87.8	89.6	89.5	54	67	73	6307	6206	19.76	CD0005

**NOTE:** See page 31 for Connection Diagrams.

## Quarry Duty Motors

Baldor Quarry Duty motors feature Design C high starting torque, making them ideal for handling start-up loads associated with conveyors. Motors are built with Class F insulation and Class B temperature rise. UL and CSA recognized component approval.



### Performance Data: TEFC – Totally Enclosed Fan Cooled, Rigid Base and C-Face, 230/460 Volts, Three Phase, 1 through 15 Hp

Hp	kW	RPM	Frame	Catalog No.	Amps		F.L. Torque Lb. Ft.	Efficiency %			Power Factor %			Bearings		"C" Dim.	Conn. Diag. No.
					F.L.	L.R.		1/2	3/4	F.L.	1/2	3/4	F.L.	DE	ODE		
2	1.5	1725	145T	M3558T-9	3.1	22	6	82.2	83.7	82.5	59	72	77	6205	6203	13.31	CD0005
3	2.2	1725	182T	M3611T-9	4.3	30	9	82.6	84.5	82.5	59	72	75	6206	6205	15.17	CD0005
5	3.7	1725	184T	M3615T-9	6.6	55	15	85.9	86.1	85.5	69	80	86	6206	6205	16.55	CD0005
7 1/2	5.6	1725	213T	M3710T-9	9.7	63	22.5	87.4	87.5	85.5	73	81	85	6307	6206	17.89	CD0005
10	7.5	1755	215T	M3714T-9	12.5	92	30	85.3	87.2	87.5	68	79	83	6307	6206	19.01	CD0005
15	11.2	1760	254T	M2333T-9	18.8	104	45	87.9	88.7	87.5	74	83	86	6309	6208	23.16	CD0005

#### C-Face Less Base

1	0.75	1725	56C	VM3581	1.7	11.6	3	73.4	77.2	77.0	49	63	74	6205	6203	12.49	CD0005
1	0.75	1725	143TC	VM3581T	1.7	11.6	3	73.1	77.1	77.0	49	63	74	6205	5203	12.56	CD0005
1 1/2	1.1	1725	145TC	VM3584T	2.5	17.3	4.5	72.0	75.5	78.5	50	66	72	6205	6203	12.56	CD0005
2	1.5	1725	145TC	VM3587T	3.1	21	6	80.5	82.3	82.5	56	69	77	6205	6203	12.56	CD0005
3	2.2	1725	182TC	VM3661T-9	4.3	30	9	82.6	84.5	84.0	59	72	75	6206	6205	15.99	CD0005
5	3.7	1725	184TC	VM3665T-9	6.6	53	15	85.8	85.8	85.5	62	74	80	6206	6205	15.99	CD0005

**NOTE:** See page 24, 25 and 28 for Layout drawing. See page 37 for Connection Diagrams.

Shaded ratings are cast iron frames.

## Crusher Duty Motors

Baldor Crusher Duty motors are ideal for belt-driven applications where severe duty service combines with requirements for high breakdown torques. In rock crushers and pellet mills, the presence of residual material from the equipment's last operation can compound start-up load. Baldor Crusher Duty motors feature extra coil bracing to keep these shock loads from damaging the windings. The motor's pulley end roller bearings and high strength steel shaft are for belted loads only; these motors are not suitable for direct-coupled loads without changing them to ball bearings in our Mod Express shop.



### Performance Data: TEFC – Totally Enclosed Fan Cooled, Rigid Base, 460 Volts, Three Phase, 100 through 300 Hp

Hp	kW	RPM	Frame	Catalog No.	Amps		F.L. Torque Lb. Ft.	Efficiency %			Power Factor %			Bearings		"C" Dim.	Conn. Diag. No.
					F.L.	L.R.		1/2	3/4	F.L.	1/2	3/4	F.L.	DE	ODE		
100	75	1775	405T	CR4400TR-4	116	733	295	92.0	93.0	93.0	79	84	87	3319	6313	36.88	CD0006
100	75	1180	444T	CR4409TR-4	124	870	445	93.1	94.1	94.1	69	76	81	NU319	6314	44.24	CD0006
125	93	1780	444T	CR4410TR-4	144	1065	367	93.4	94.5	94.5	77	84	86	NU319	6314	44.24	CD0006
125	93	1180	445T	CR4411TR-4	153	1150	557	94.9	95.4	95.0	70	82	78	6319	6314	47.74	CD0006
150	112	1780	445T	CR4406TR-4	171	1410	440	94.2	95.1	95.0	77	85	86	NU319	6314	44.24	CD0006
150	112	1180	447T	CR44156TR-4	182	1344	667	95.3	95.7	95.0	71	82	78	6319	6314	47.74	CD0006
200	149	1780	447T	CR4407TR-4	240	1850	590	93.1	94.5	95.0	70	78	83	NU319	6314	47.74	CD0006
200	149	1185	449T	CR44206TR-4	244	1495	886	92.6	93.6	93.6	70	79	81	N319	6314	54.37	CD0006
250	187	1780	449T	CR4408TR-4	282	2105	738	93.7	94.2	94.5	76	85	89	N319	6314	54.37	CD0006
250	187	1180	449T	CR44256TR-4	308	2043	1103	92.0	92.8	94.1	73	80	81	N319	6314	54.37	CD0695
300	224	1185	449T	CR44306TR-4	372	2364	1330	95.0	95.4	95.4	68	77	80	N319	6314	54.37	CD0382

**NOTE:** See page 24 for Layout drawing. See page 37 and 37 for Connection Diagrams.

Shaded ratings are cast iron frames.

Efficiencies shown are nominal.

Data subject to change without notice. Contact Baldor for certified data.

## Explosion-Proof Motors

Baldor 1.15 Service Factor Explosion Proof motors are designed and built for on- and off-shore drill rig service, bulk fuel terminals, and transfer stations where a volatile gaseous or vapor atmosphere combines with salt water conditions to provide a unique challenge. These motors meet Class I, Group C & D specifications, with extra corrosion resistance against seawater and sea air. A 1.15 Service Factor provides for temporary overload capability.



### Performance Data: TEFC – Totally Enclosed Fan Cooled, Rigid Base, 230/460 Volts, Three Phase, 3 through 100 Hp

Hp	kW	RPM	Frame	Catalog No.	Amps		F.L. Torque Lb. Ft.	Efficiency %			Power Factor %			Bearings		"C" Dim.	Conn. Diag. No.
					F.L.	L.R.		1/2	3/4	F.L.	1/2	3/4	F.L.	DE	ODE		
3	2.2	1750	182T	M7042T-I	4.1	34.6	9.8	86.4	88.1	87.5	58	70	78	6206	6205	18.27	CD0005
5	3.7	1750	184T	M7044T-I	6.7	53	15	87.3	88.4	87.5	63	74	80	6206	6205	18.27	CD0005
7.5	5.6	1760	213T	M7047T-I	10.2	69.1	22.2	87	89	89.5	61	72	76	6307	6206	20.32	CD0005
10	7.5	1760	215T	M7170T-I	14.2	100	29.9	87.8	89.6	89.5	54	67	73	6307	6206	20.03	CD0005
15	11.2	1770	254T	M7054T-I	18	131	44.1	91.1	92.4	91	69	79	84	6309	6208	25.50	CD0005
20	14.9	1760	256T	M7056T-I	24	168	59.3	90.2	91.6	91	71	80	84	6309	6208	25.50	CD0005
25	18.7	1775	284T	M7058T-I	30.8	188	74.4	90	91.8	92.4	71	80	84	6311	6309	28.61	CD0005
30	22.4	1770	286T	M7060T-I	36	208	90	90.1	91.7	92.4	73	81	84	6311	6309	28.61	CD0005
40	30	1775	324T	M7062T-I	47	322	118	93.1	94.1	93	74	82	86	6312	6311	32.00	CD0180
50	37	1775	326T	M7064T-I	60	398	149	91.4	92.9	93	75	83	86	6312	6311	32.00	CD0180
60	45	1780	364T	M7066T-I	69	441	177	92.2	93.5	93.6	75	83	86	6313	6312	33.25	CD0180
75	56	1780	365T	M7068T-I	85	608	222	93.6	94.5	94.1	78	85	88	6313	6312	33.25	CD0005
100	75	1780	405T	M7090T-I	113	703	295	94.8	95.2	94.5	79	85	87	6316	6313	38.75	CD0180

**NOTE:** See page 29 for Layout drawing. See page 37 for Connection Diagrams.

Shaded ratings are cast iron frames.

### Performance Data: TEFC – Totally Enclosed Fan Cooled, Rigid Base, 575 Volts, Three Phase, 3 through 100 Hp

Hp	kW	RPM	Frame	Catalog No.	Amps		F.L. Torque Lb. Ft.	Efficiency %			Power Factor %			Bearings		"C" Dim.	Conn. Diag. No.
					F.L.	L.R.		1/2	3/4	F.L.	1/2	3/4	F.L.	DE	ODE		
3	2.2	1750	182T	M7042T-I-5	3.3	25.9	8.9	86.1	87.8	87.5	59	71	78	6206	6205	18.27	CD0006
5	3.7	1750	184T	M7044T-I-5	5.2	41	15	87.3	88.4	87.5	63	74	80	6206	6205	18.27	CD0006
7.5	5.6	1760	213T	M7047T-I-5	8.2	58	22.2	87.7	89.7	89.5	57	69	76	6307	6206	20.32	CD0006
15	11.2	1770	254T	M7054T-I-5	14.4	105	44.1	91.1	92.4	91	69	79	84	6309	6208	25.50	CD0006
20	14.9	1760	256T	M7056T-I-5	19.2	134	59.3	90.2	91.6	91	71	80	84	6309	6208	25.50	CD0006
25	18.7	1775	284T	M7058T-I-5	24.6	150	74.4	90	91.8	92.4	71	80	83	6311	6309	28.61	CD0006
30	22.4	1770	286T	M7060T-I-5	28.8	166	90	90.1	91.7	92.4	73	81	84	6311	6309	28.61	CD0006
40	30	1775	324T	M7062T-I-5	37.6	258	118	93.1	94.1	93	74	82	86	6312	6311	32.00	CD0006
50	37	1775	326T	M7064T-I-5	47	304	148	94.2	94.7	94.5	72	81	84	6312	6311	32.12	CD0006
60	45	1780	364T	M7066T-I-5	56	362	177	94.7	95.2	93.6	71	81	86	6313	6312	33.25	CD0006
75	56	1780	365T	M7068T-I-5	69	506	222	93.6	94.5	94.1	78	85	88	6313	6312	33.25	CD0006
10	7.5	1760	215T	M7070T-I-5	11.4	80	29.9	87.8	89.6	89.5	54	67	73	6307	6206	20.03	CD0006
100	75	1780	405T	M7090T-I-5	91	551	295	94.8	95.2	94.5	74	82	87	6316	6313	38.75	CD0006

**NOTE:** See page 29 for Layout drawing. See page 37 for Connection Diagrams.

Shaded ratings are cast iron frames.

Efficiencies shown are nominal.

Data subject to change without notice. Contact Baldor for certified data.

## Explosion-Proof Motors

**Performance Data: TEFC – Totally Enclosed Fan Cooled, C-Face with Base, 230/460 Volts, Three Phase, 3 through 50 Hp**

Hp	kW	RPM	Frame	Catalog No.	Amps		F.L. Torque Lb. Ft.	Efficiency %			Power Factor %			Bearings		"C" Dim.	Conn. Diag. No.
					F.L.	L.R.		1/2	3/4	F.L.	1/2	3/4	F.L.	DE	ODE		
3	2.2	1750	182TC	CM7042T-I	4.1	34.6	9.01	86.4	88.1	87.5	58	70	78	6206	6205	19.59	CD0005
5	3.7	1750	184TC	CM7044T-I	6.7	53	15	87.3	88.4	87.5	63	74	80	6206	6205	19.59	CD0005
7.5	5.6	1760	213TC	CM7047T-I	10.2	69.1	22.2	87	89	89.5	61	72	76	6307	6206	21.07	CD0005
10	7.5	1760	215TC	CM7170T-I	14.2	100	29.9	87.8	89.6	89.5	54	67	73	6307	6206	20.77	CD0005
15	11.2	1770	254TC	CM7054T-I	18	131	44.1	91.1	92.4	91	69	79	84	6309	6208	26.00	CD0005
20	14.9	1760	256TC	CM7056T-I	24	168	59.3	90.2	91.6	91	71	80	84	6309	6208	26.00	CD0005
25	18.7	1775	284TC	CM7058T-I	30.8	188	74.4	90	91.8	92.4	71	80	84	6311	6309	28.61	CD0005
30	22.4	1770	286TC	CM7060T-I	36	208	90	90.1	91.7	92.4	73	81	84	6311	6309	28.61	CD0005
50	37	1775	326TC	CM7064T-I	60	398	149	91.4	92.9	93	75	83	86	6312	6311	32.00	CD0180

**NOTE:** See page 29 for Layout drawing. See page 37 for Connection Diagrams.

Shaded ratings are cast iron frames.

## P-Base Vertical Pump Motors

These solid shaft motors are ideal for medium and high thrust in-line pump applications, including aerators for wastewater treatment plants, petroleum refineries, chemical plants, pulp and paper mills, and agriculture irrigation. Features include thrust bearings in an oil bath, 1.15 Service Factor, cast iron frame, corrosion resistant epoxy finish, shaft seals, and dual lifting lugs.



**Performance Data: TEFC – Totally Enclosed Fan Cooled, P-Base, 230/460 Volts, Three Phase, 3 through 75 Hp**

Hp	kW	RPM	Frame	Catalog No.	Amps		F.L. Torque Lb. Ft.	Efficiency %			Power Factor %			Bearings		Max Thrust Load	"C" Dim.	Conn. Diag. No.
					F.L.	L.R.		1/2	3/4	F.L.	1/2	3/4	F.L.	DE	ODE			
<b>Medium Thrust</b>																		
3	2.2	3450	182LP	VLCP3660T	3.9	33	4.5	78.3	81.2	80	77	85	87	QJ307	6206	710	22.18	CD0005
3	2.2	1725	182LP	VLCP3661T	4.3	30	9	82.6	84.5	84	59	72	75	QJ307	6206	983	22.18	CD0005
5	3.7	3450	184LP	VLCP3663T	6	56	7.5	82.6	85.4	86	82	89	93	QJ307	6206	710	22.18	CD0005
5	3.7	1725	184LP	VLCP3665T	6.6	53	15	85.8	85.8	85.5	62	74	80	QJ307	6206	983	22.18	CD0005
7 1/2	5.6	3450	213LP	VLCP3769T	9.1	70	11.3	80.7	83.1	84	86	91	92	QJ211	6307	1020	22.33	CD0005
7 1/2	5.6	1750	213LP	VLCP3770T	10	80	22.5	84.9	87	87.5	63	75	82	QJ211	6307	1290	22.33	CD0005
10	7.5	3450	213LP	VLCP3771T	12	106	15	82.8	85.2	85.5	86	90	91	QJ211	6307	1020	22.33	CD0005
10	7.5	1750	213LP	VLCP3774T	13.5	112	30	85.9	87.6	87.5	63	74	77	QJ211	6307	1290	22.33	CD0005
15	11.2	3500	254LP	VLCP2394T	18.5	137	22.5	86.4	87.2	86.5	83	89	91	QJ211	6307	1350	22.33	CD0005
15	11.2	1760	254LP	VLCP2333T	19	119	45	89.3	90.1	90.2	65	74	82	QJ211	6307	1700	22.33	CD0005
20	14.9	3515	256LP	VLCP4106T	23	160	29.5	87.5	89.3	89.5	79	87	89	QJ213	6208	1350	25.72	CD0180
20	14.9	1760	256LP	VLCP2334T	26	205	60	88.2	89.4	89.5	63	74	81	QJ213	6208	1700	25.72	CD0005
25	18.6	3525	284LP	VLCP4107T	28	183	37	89.8	91	91	83	90	91	QJ213	6309	1350	32.44	CD0005
25	18.6	1760	286LP	VLCP4103T	30	181	75	90.6	91.7	91	73	81	85	QJ213	6309	1700	32.44	CD0005
30	22.4	3525	286LP	VLCP4108T	33	224	44.4	91	92.1	91.7	87	91	91	QJ213	6309	1350	32.44	CD0005
30	22.4	1760	286LP	VLCP4104T	37	195	90	90.7	91.5	91	78	84	85	QJ213	6309	1700	32.44	CD0005
40	30	3530	324LP	VLCP4109T	45	285	59.5	90.9	91.8	91.7	84	88	90	QJ312	6311	1880	34.72	CD0180
40	30	1775	324LP	VLCP4110T	47	300	119	92.4	93.2	93	73	82	85	QJ312	6311	2370	34.72	CD0180
<b>High Thrust</b>																		
50	37	3550	326VP	VPCP4114T	58	368	74	89.8	90.7	90.2	82	88	90	QJ311	6311	3410	34.71	CD0180
50	37	1760	326VP	VPCP4115T	60	338	150	91	91.8	91	74	82	86	QJ312	6311	4300	34.71	CD0005
60	45	3550	364VP	VPCP4310T	69	422	90	87	89	90.2	76	84	91	QJ311	6312	3410	38.04	CD0180
60	45	1775	364VP	VPCP4314T	70	430	177	92.8	93.7	93.6	75	83	86	QJ314	6312	6000	38.04	CD0180
75	56	3550	365VP	VPCP4313T	84	650	111	89	90.8	91	84	90	92	QJ311	6312	3410	38.04	CD0180
75	56	1775	365VP	VPCP4316T	86	566	222	93.4	94.3	94.1	77	85	87	QJ314	6312	6000	38.04	CD0005

**NOTE:** See page 30 for Layout drawing. See page 37 for Connection Diagrams.

Shaded ratings are cast iron frames.

Efficiencies shown are nominal.

Data subject to change without notice. Contact Baldor for certified data.

## Conduit Box Volumes – Cast Iron Frames

Motor Frame Size	Baldor ECP Volume IN <sup>3</sup>	Baldor IEEE 841 Volume IN <sup>3</sup>	Conduit Hole Size (NPT)
143T/145T	20.3	34	0.75
182T/184T	20.3	34	0.75
213T/215T	69	69	1.0
254T/256T	69	69	1.25
284T/286T	140	140	1.5
324T/326T	140	140	2.0
364T/365T	140	388	2.0
404T/405T	459	459	3.0
444T/445T	600	1020	3.0
445T/447T	1608	1608	4.0
447T/449T	1608	1608	4.0
5007/5009/5011	2100	1540	4 (2)
5810/5812	3000	-	4 (3)

**Note:** All Baldor Severe Duty motors use lead separator gasket between box and frame is a neoprene rubber "cone" design for a water-tight seal around the lead wires. Conduit box lid gasket is neoprene rubber. Grounding provision is located inside the conduit box. Additional and/or larger conduit boxes are available.

## Conduit Box Volumes – Steel Band

Motor Frame Size	Baldor Volume IN <sup>3</sup>	UL/NEC Minimum Volume IN <sup>3</sup>	NPT Hole Size
56	10.6	10.5	0.875
143T/145T	18.5	16.8	0.75
182T/184T	24.9	16.8	0.75
213T/215T	39.8	36.4	1.0
254T/256T	79	36.4	1.25

### Approvals UL and CSA

All NEMA 42 through 445T, equivalent IEC frame motors (Inverter and Vector Drive motors) are listed under UL recognized component file # E46145. All NEMA 42 through 449T frame motors are listed under CSA recognized component file #LR2262. TEFC or TEBC 5000 and 5800 frame motors up to 4160 volts, and a maximum of 900 hp - 2 pole, 800 hp - 4 pole, and 700 hp 6 pole are listed under CSA recognized component file # LR36841-7.

## Inverter and Vector Controls for Even More Energy Efficiency

Whether you're looking for energy savings, better process control, or increased productivity, chances are Baldor has the right drive for your application. Inverter controls are used in variable or constant torque applications with Inverter Ready or Inverter Duty motors. Vector controls are ideal for applications where precise positioning, speed control and holding torque are required, or where overall system performance can be improved. Vector drives can provide full-rated torque at zero speed.

Baldor currently offers a wide variety of motor control products including Washdown enclosures, Fan and Pump variable torque inverters and Soft Starters. Additionally, Baldor can build controls to your specifications, including panels with control by-pass devices. Contact your local Baldor distributor or Baldor District Office for more information.



**INVERTER READY**  
PER NEMA STD MG1  
PART 31.4.4.2

This label identifies Baldor Inverter Ready motors.

### Baldor Super-E Motors 230, 460 and 575 Volts

Family	Frame Size	Constant Torque	Variable Torque	Comments
EM (TEFC)	143 – 449	20:1	20:1	General Purpose Premium Efficiency
EM (ODP)	143 – 445	20:1	20:1	General Purpose Premium Efficiency
ECP	143 – 449	20:1	20:1	Severe Duty Premium Efficiency
ECP8 (IEEE841)	143 – 449	20:1	20:1	Severe Duty Premium Efficiency May not meet temp rise as specified in IEEE841 when used with ASD.
EWDM	143 - 215	20:1	20:1	Washdown Duty Premium Efficiency

### Baldor Standard-E Motors 230, 460 and 575 Volts

Family	Frame Size	Constant Torque	Variable Torque	Comments
M (TEFC)	143 – 5009	4:1	10:1	General Purpose
M (ODP)	143 – 5009	4:1	10:1	General Purpose
CP	143 – 405	4:1	10:1	Severe Duty
WDM	56 - 215	4:1	10:1	Washdown Duty

### Baldor Inverter Duty and Vector Duty Motors 230, 460 and 575 Volts

Family	Frame Size	Constant Torque	Variable Torque	Comments
IDM (TEBC)	143 – 5009	1000:1	1000:1	Inverter Duty/Blower cooled
IDNM (TENV)	143 - 256	1000:1	1000:1	Inverter Duty/Non-Vented
ZDM (TEBC)	143 – 5009	1000:1	1000:1	Vector Duty/Blower Cooled
ZDNM (TENV)	143 - 256	1000:1	1000:1	Vector Duty/Non Vented
IDXM (2 families)	56 – 405 182 - 405	2:1 10:1	10:1 10:1	Explosion Proof Inverter Duty
IDWNM	143 - 254	1000:1	1000:1	Washdown Duty Inverter Duty/Non Vented
ZDWNM	143 - 254	1000:1	1000:1	Washdown Duty Vector Duty/Non Vented

**NOTE:** See page 8 for application details.

## Matched Performance™: The Perfect Motor and Control for Your Application

Many motor and drive manufacturers claim that their products are designed to work together, but only Baldor backs up the claim with specific data. Introduced in 1993, Matched Performance provides lab-tested performance curve data on Baldor motors and controls, 1 to 800 hp, including inverters, vectors, DC SCR drives and servos. Showing peak torque, continuous torque, maximum speed and current, each Matched Performance curve illustrates the continuous and intermittent torque available from the motor at various speeds. This lets you know the motor's safe operating envelope below and above its base speed.

### Examples:

At right are two examples of Matched Performance Curves, both showing 10 hp motors, operated from different controls.

The top curve is an ECP3774T Inverter Ready Super-E motor operated from a Baldor 15H Inverter control. As you can see, the motors rated torque is 30 lb-ft, available from 90-1800 rpm, with a continuous hp operation to 3500 rpm. Speed regulation for an inverter-fed motor is approximately 2-3% of base Speed. Super-E motors with Inverters are ideally suited for variable torque loads, such as fans and centrifugal pumps. Then also work well for constant torque loads like conveyors, where precise speed control or low speed operation is not required.

The bottom curve is a ZDM3774T Vector Drive motor operated from a Baldor 18H Vector Control. Almost 200% of rated torque at zero speed is available. Full rated torque - or more - is available to 6000 rpm. With encoder feedback, the Vector Drive can maintain speed precisely 0.01% of set speed, and has the capability to do positioning like a servo motor. Vectors are well suited for applications where precise speed and position control contribute to system efficiency and productivity, like metered bulk-solid feeder operations.

\* NOTE: Baldor Inverters are supplied with NEMA 1 enclosures which are not approved for hazardous locations and should be remotely mounted. If the inverter drive needs to be mounted near the motor, contact your local Baldor district office.

### Matched Performance Curve for 10 Hp Super-E® Motor and Control\*

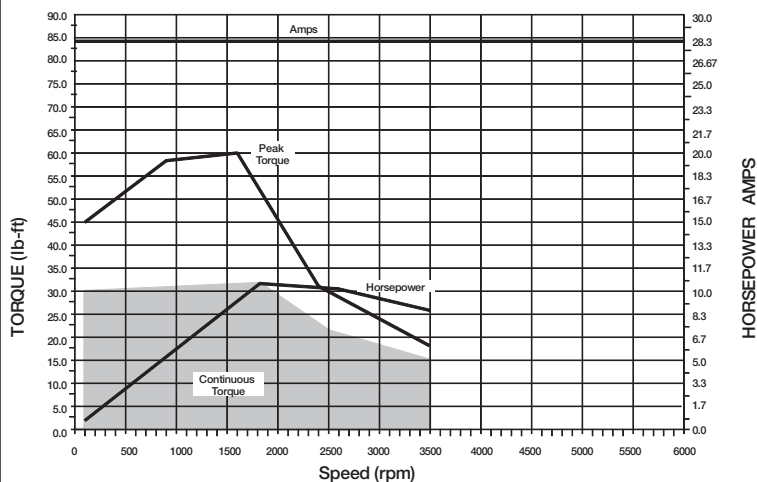

Motor: ECP3774T - 10 Hp  
Control: ID15H210-E - 10 Hp Series 15H Inverter

### Matched Performance Curve for 10 Hp Vector Drive® Motor and Control\*

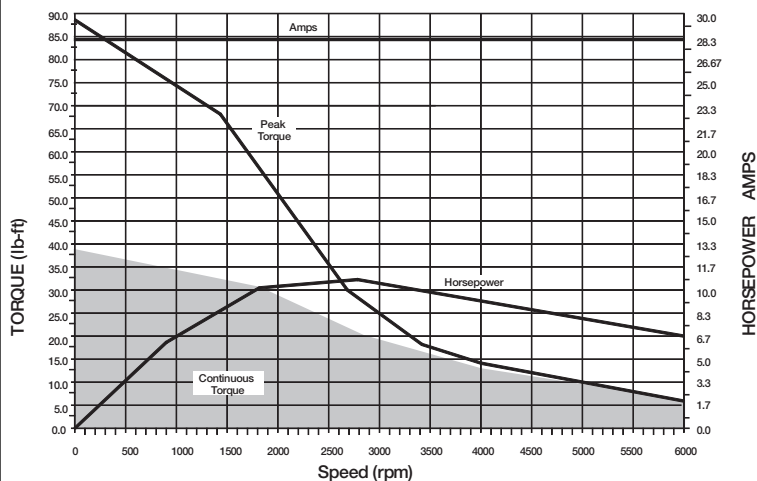

Motor: ZDM3774T - 10 Hp  
Control: ZD18H210-E - 10 Hp Series 15H Inverter

## Dimensions

**Chemical Processing, Dirty Duty, Quarry Duty and Crusher Duty - Horizontal Base Mount  
Cast Iron Construction - Totally Enclosed, Fan-Cooled - NEMA 143T Through 449T**

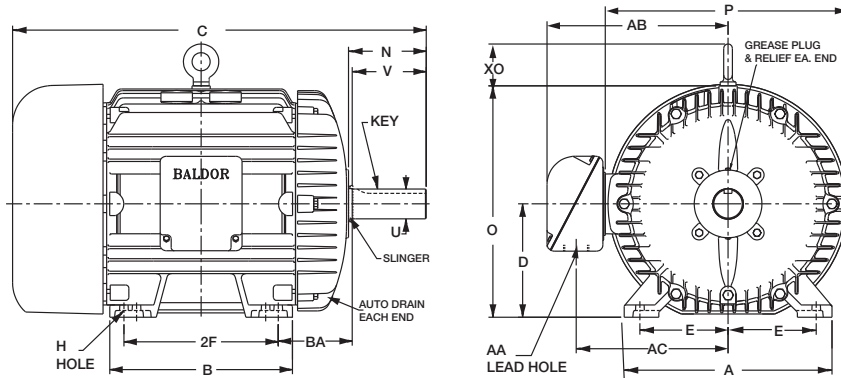

NEMA Frame	A	B	D	E	2F	H	KEY	N	O	P	U	V	AA	AB	AC	BA
143T					4.00								0.75			
145T	6.50	5.88	3.50	2.75	5.00	0.38	0.188	2.50	7.48	8.00	0.875	2.25	NPT	6.38	5.00	2.25
182T					4.50											
600Typ	8.62	6.50	4.50	3.75	5.50	0.41	0.25	2.81	9.23	10.12	1.125	2.75	0.75	7.12	5.75	2.75
184T					5.50								NPT			
213T					5.50								1.00			
215T	9.62	8.12	5.25	4.25	7.00	0.41	0.31	3.88	10.99	11.88	1.375	3.38	NPT	8.82	7.25	3.50
254T					8.25											
700Typ	11.50	11.50(4)	6.25	5.00	10.00	0.53	0.38	4.66	12.18	11.88	1.625	4.00	1.25	9.00	7.43	4.25
256T		9.75(8)			10.00								NPT			
254T					8.25											
900Typ	11.50	11.50	6.25	5.00	10.00	0.53	0.38	4.38	12.88	12.94	1.625	4.00	1.25	10.01	8.23	4.25
256T					10.00								NPT			
284T					9.50								1.25			
286T	12.76	12.75	7.00	5.50	11.00	0.56	0.50	4.91	14.66	15.57	1.875	4.62	NPT	12.55	10.22	4.75
324T					10.50								2.00			
326T	14.50	14.00	8.00	6.25	12.00	0.66	0.50	5.56	16.25	17.85	2.125	5.25	NPT	13.91	11.60	5.25
364T					11.25								2.00			
365T	16.50	14.50	9.00	7.00	12.25	0.65	0.62	6.17	18.38	19.25	2.375	5.88	NPT	14.37	12.06	5.88
404T					12.25								2.50			
405T	18.88	16.63	10.00	8.00	13.75	0.81	0.75	7.50	20.31	21.61	2.875	7.25	NPT	17.74	14.44	6.62
444T					14.50								2.50			
445T	21.75	20.25	11.00	9.00	16.50	0.81	0.88	8.94	22.94	24.56	3.375	8.50	NPT	20.49	16.00	7.50
447T					14.50								2.50			
449T	21.75	23.75	11.00	9.00	20.00	0.81	0.88	8.94	22.94	24.56	3.375	8.50	NPT	20.51	15.99	7.50
449TY					25.00								4.00			
449TY	21.75	28.75	11.00	9.00	25.00	0.81	0.875	10.10*	22.94	24.56	3.375	8.50	NPT	21.71	16.75	7.50

**Note:** NEMA 254-256T Catalog # ECP2276T, ECP2332T, AB= 10.10, AC= 8.27. Catalog CP2332T-4. NEMA 284-286T Catalog #ECP4100T, ECP4102T, ECP4103T, ECP4104T, AB= 12.56, AC= 10.56. NEMA 404-405T (ECP4400T) N=7.50, P= 21.55. NEMA 449TY with drive end fan and shroud N= 10.10

### NEMA Style "S" Shaft Dimensions

NEMA Frame	Key	N	U	V	NEMA Frame	Key	N	U	V
284TS		3.35(ECP)			404TS				
286TS	0.38	3.53	1.625	3.25	405TS	0.50	4.50	2.12	4.25
324TS					444TS				
326TS	0.50	4.06	1.875	3.75	445TS	0.62	6.44	2.37	4.75
364TS					447TS		6.44		
365TS	0.50	4.05	1.875	3.75	449TS	0.62	4.93	2.37	4.75

**Note:** Drawings shown are for reference only. Please contact Baldor for a detailed dimensional drawing of the specific motor you require.

Drawings may also be available from our CD-ROM or website at [www.baldor.com](http://www.baldor.com)

## Dimensions

### Chemical Processing Dirty Duty and Quarry Duty Cast Iron Construction C-Face Less Base Motors, Totally Enclosed, Fan-Cooled - NEMA 56C Through 215TC

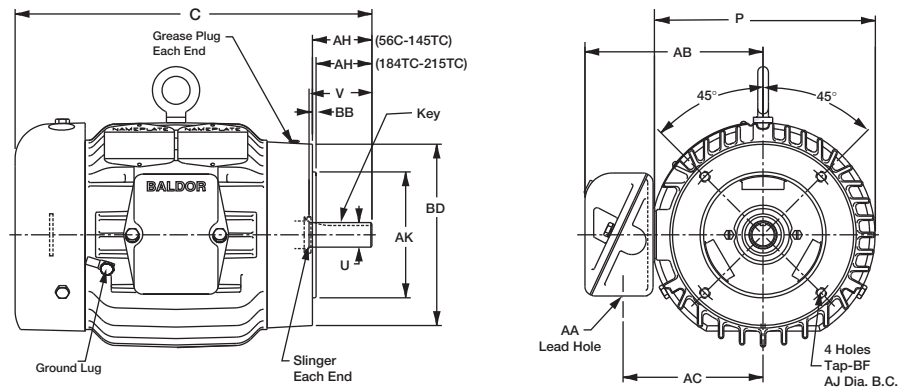

NEMA Frame	Key	P	U	V	AA	AB	AC	AH	AJ	AK	BB	BD	Tap BF
56C	0.19	8.02	0.625	1.88	0.75 NPT	6.36	5.00	2.06	5.88	4.50	0.13	6.48	3/8-16
143TC 145TC	0.19	8.02	0.875	2.25	0.75 NPT	6.43	5.00	2.12	5.88	4.50	0.13	6.48	3/8-16
182TC 184TC	0.25	9.00	1.125	2.75	0.75 NPT	7.12	5.75	2.62	7.25	8.50	0.25	8.87	1/2-13
213TC 215TC	0.31	12.18	1.375	3.38	1.00 NPT	8.83	7.25	3.12	7.25	8.50	0.25	9.06	1/2-13

**Note:** Drawings shown are for reference only. Please contact Baldor for a detailed dimensional drawing of the specific motor you require. Drawings may also be available from our CD-ROM or website at [www.baldor.com](http://www.baldor.com)

## Dimensions

### 5000 Frame - Chemical Processing - Cast Iron Construction Motors Totally Enclosed, Fan-Cooled - NEMA 5007 Through 5011

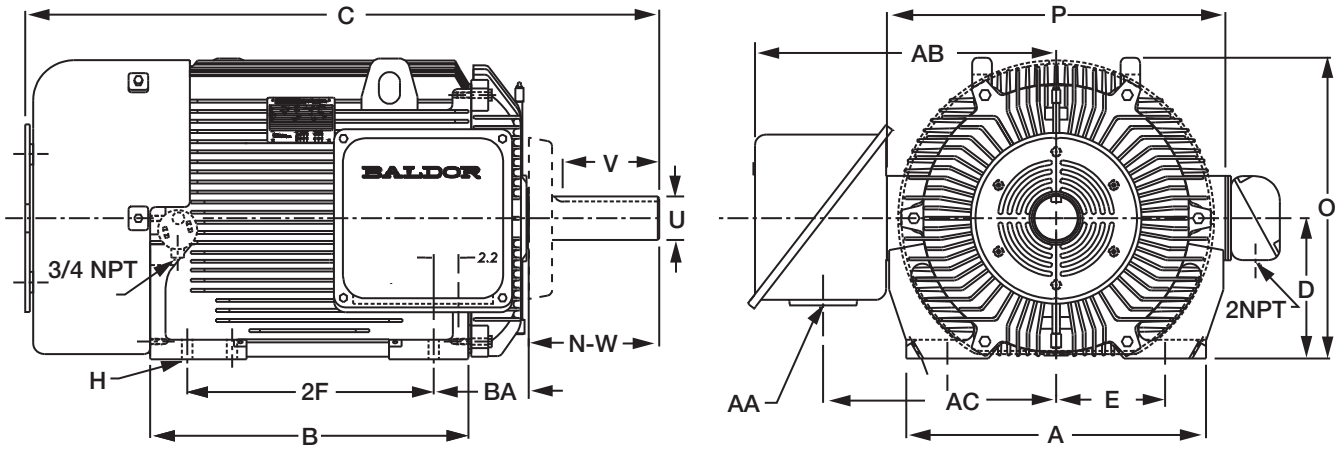

NEMA Frame	A	B	C	D	E	2F	H	N-W	O	P	U	V	AA	AB	BA
5007S*	25.63	28.41	53.66	12.5	10	18 & 22	.81	8.47	26.84	30	2.5	6.5	4-NPT	26.88	8.5
5007L**	25.63	28.41	56.56	12.5	10	18 & 22	.81	11.63	26.84	30	3.875	11.13	4-NPT	26.88	8.5
5009S*	25.63	34.41	59.66	12.5	10	25 & 28	.81	8.47	26.84	30	2.5	6.5	4-NPT	26.88	8.5
5009L**	25.63	34.41	62.56	12.5	10	25 & 28	.81	11.63	26.84	30	3.875	11.13	4-NPT	26.88	8.5
5011S*	25.63	42.44	67.66	12.5	10	32 & 36	.81	8.47	26.84	30	2.5	6.5	4-NPT	26.88	8.5
5011L**	25.63	42.44	70.56	12.5	10	32 & 36	.81	11.63	26.84	30	3.875	11.13	4-NPT	26.88	8.5
5011L***	25.63	42.44	71.81	12.5	10	32 & 36	.81	12.5	26.84	30	3.875	11.13	4-NPT	26.88	8.5

**Note:** \*2-pole only, \*\*4-6-8 pole, \*\*\*4-6-8 pole only. Design has shaft end bearing cooling fan.

Drawings shown are for reference only. Please contact Baldor for a detailed dimensional drawing of the specific motor you require. Drawings may also be available from our CD-ROM or website at [www.baldor.com](http://www.baldor.com).

## Dimensions

### Three Phase Cast Iron Construction Motors - IEEE 841 Totally Enclosed, Fan-Cooled - NEMA 143T through 449T

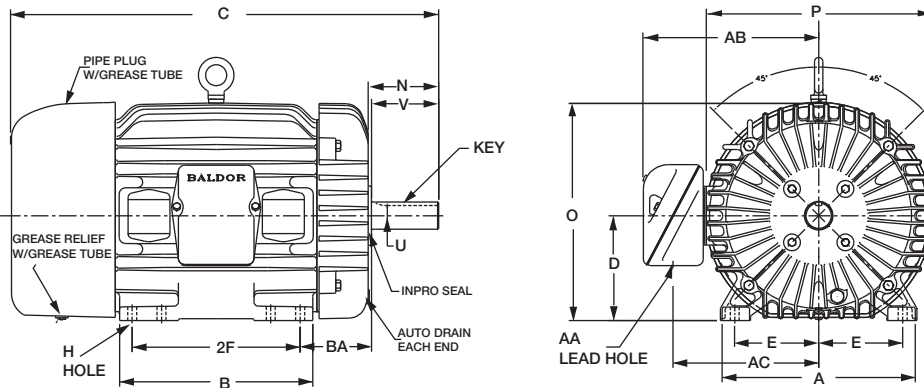

NEMA Frame	A	B	D	E	2F	H	Key	N	O	P	U	V	AA	AB	AC	BA
143T																
145T	6.50	5.88	3.50	2.75	5.00	0.38	0.19	2.50	7.48	8.00	0.875	2.25	0.75	6.38	5.00	2.25*
182T					4.50											
184T	8.62	6.50	4.50	3.75	5.50	0.41	0.25	2.81	9.23	10.12	1.125	2.75	0.75	7.12	5.75	2.75
213T					5.50											
215T	9.62	8.12	5.25	4.25	7.00	0.41	0.31	3.88	10.99	12.18	1.375	3.38	1.00	9.22	7.43	3.50
254T					8.25											
256T	11.50	11.50	6.25	5.00	10.00	0.53	0.38	4.20	12.96	13.44	1.625	4.00	1.25	10.48	8.66	4.25
284T					9.50											
286T	12.76	12.75	7.00	5.50	11.00	0.53	0.38	4.88	14.74	15.54	1.875	4.63	1.50	12.46	10.14	4.75
284TS					9.50											
286TS	12.76	12.75	7.00	5.50	11.00	0.53	0.38	3.50	14.74	15.54	1.625	3.25	1.50	12.46	10.14	4.75
324T					10.50											
326T	14.50	14.00	8.00	6.25	12.00	0.66	0.50	5.56	16.25	17.85	2.125	5.25	2.00	14.06	11.75	5.25
324TS					10.50											
326TS	14.50	14.00	8.00	6.25	12.00	0.66	0.50	4.06	16.68	17.40	1.875	3.75	2.00	13.37	11.05	5.25
364T					11.25											
365T	16.50	14.50	9.00	7.00	12.25	0.65	0.62	6.17	18.38	19.25	2.375	5.88	2.00	16.71	13.15	5.88
364TS					11.25											
365TS	16.50	14.50	9.00	7.00	12.25	0.66	0.50	4.06	18.44	19.28	1.875	3.75	2.00	16.59	13.03	5.88
404T					12.25											
405T	18.88	16.63	10.00	8.00	13.75	0.81	0.75	7.50	20.31	21.55	2.875	7.25	3.00	18.84	15.15	6.63
404TS					12.25											
405TS	19.50	16.75	10.00	8.00	13.75	0.81	0.50	4.56	21.00	20.88	2.125	4.25	2.50	18.27	13.78	6.62
444T					14.50											
445T	21.75	20.25	11.00	9.00	16.50	0.81	0.88	9.08	22.94	24.56	3.375	8.50	3.00	20.59	16.02	7.50
444TS					14.50											
445TS	21.75	20.25	11.00	9.00	16.50	0.81	0.62	4.90	22.94	24.81	2.375	4.75	3.00	20.82	16.28	7.50
445T					16.50											
447T	21.75	23.75	11.00	9.00	20.00	0.81	0.88	9.07	22.94	24.56	3.375	8.50	3.00	20.57	16.03	7.50
447T					20.00											
449T	21.75	28.75	11.00	9.00	25.00	0.81	0.88	8.94	22.94	24.56	3.375	8.50	4.00	21.71	16.75	7.50
447TS					15.00											
449TS	21.75	23.75	11.00	9.00	20.00	0.81	0.62	4.90	22.94	24.81	2.375	4.75	4.00	21.97	17.00	7.50

**Note:** \* Non-NEMA dimension. Drawings shown are for reference only. Please contact Baldor for a detailed dimensional drawing of the specific motor you require. Drawings may also be available from our CD-ROM or website at [www.baldor.com](http://www.baldor.com)

## Dimensions

### Three Phase Cast Iron Construction Motors - IEEE 841 Totally Enclosed, Fan-Cooled - NEMA 143TC through 365TC - C-Face With Base

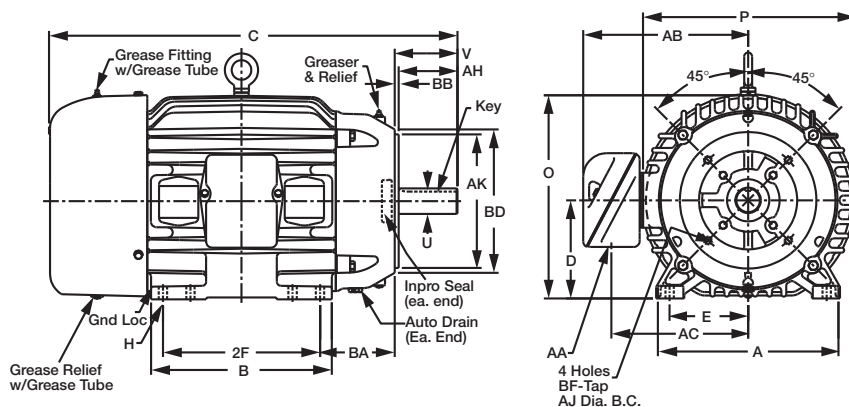

NEMA Frame	A	B	D	E	2F	H	Key	O	P	U	V	AA	AB	AC	AH	AJ	AK	BB	BD	Tap BF	BA
143TC					4.00																
145TC	6.50	5.88	3.50	2.75	5.00	0.38	0.19	7.48	8.00	0.875	2.12	0.75	6.38	5.00	2.25	5.88	4.50	0.13	6.51	0.38-16	2.25*
182TC					4.50																
184TC	8.62	6.50	4.50	3.75	5.50	0.41	0.25	9.23	10.12	1.125	2.62	0.75	7.12	5.75	2.75	7.25	8.50	0.25	9.00	0.50-13	2.75
213TC					5.50																
215TC	9.62	8.12	5.25	4.25	7.00	0.41	0.31	10.99	12.18	1.375	3.38	1.00	9.22	7.43	3.12	7.25	8.50	0.25	9.06	0.50-13	3.50
254TC					8.25																
256TC	11.50	11.50	6.25	5.00	10.00	0.53	0.38	12.96	13.44	1.625	4.00	1.25	10.48	8.66	3.75	7.25	8.50	0.25	9.13	0.50-13	4.25
284TC					9.50																
286TC	12.76	12.75	7.00	5.50	11.00	0.53	0.38	14.74	15.54	1.875	4.63	1.50	12.46	10.14	4.38	9.00	10.50	0.25	11.23	0.50-13	4.75
284TSC					9.50																
286TSC	12.76	12.75	7.00	5.50	11.00	0.53	0.38	14.74	15.54	1.625	3.25	1.50	12.46	10.14	3.00	9.00	10.50	0.25	11.23	0.50-13	4.75
324TC					10.50																
326TC	14.50	14.00	8.00	6.25	12.00	0.66	0.50	16.25	17.85	2.125	5.25	2.00	14.06	11.75	5.00	11.00	12.50	0.25	13.40	0.62-11	5.25
324TSC					10.50																
326TSC	14.50	14.00	8.00	6.25	12.00	0.66	0.50	16.68	17.40	1.875	3.75	2.00	13.37	11.05	3.50	11.00	12.50	0.25	13.40	0.62-11	5.25
364TC					11.25																
365TC	16.50	14.50	9.00	7.00	12.25	0.65	0.62	18.38	19.25	2.375	5.88	2.00	16.71	13.15	5.63	11.00	12.50	0.25	12.90	0.62-11	5.88
364TSC					11.25																
365TSC	16.50	14.50	9.00	7.00	12.25	0.66	0.50	18.44	19.28	1.875	3.75	2.00	16.59	13.03	3.50	11.00	12.50	0.25	12.90	0.62-11	5.88

**Note:** Drawings shown are for reference only. Please contact Baldor for a detailed dimensional drawing of the specific motor you require. Drawings may also be available from our CD-ROM or website at [www.baldor.com](http://www.baldor.com)

## Dimensions

### Dirty Duty and Quarry Duty Motors Totally Enclosed, Fan-Cooled - NEMA 56 Through 256T

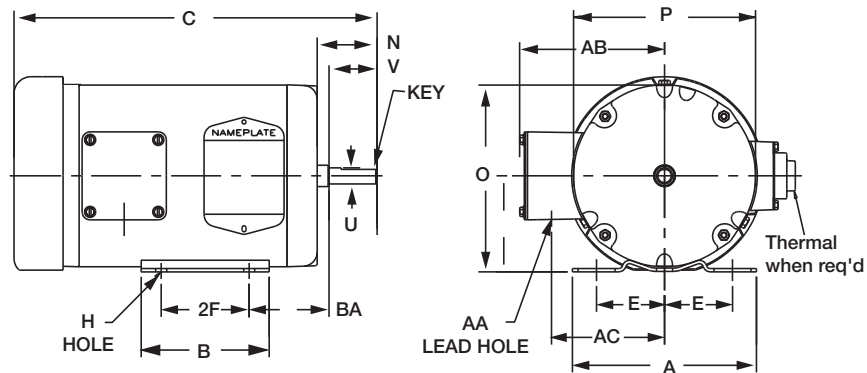

#### Steel Band Construction

NEMA Frame	A	B	D	E	2F	H	Key	N	O	P	U	V	AA	AB	AC	BA
56	6.56	4.25	3.50	2.44	3.00	0.34	0.19	2.50	6.34	5.69	0.625	1.87	0.50	4.51	3.53	2.75
143T					4.00											
145T	6.50	5.94	3.50	2.75	5.00	0.34	0.19	2.50	6.81	6.62	0.875	2.25	0.88	5.73	4.62	2.25
182T					4.50											
184T	8.63	6.50	4.50	3.75	5.50	0.41	0.25	3.56	8.44	7.88	1.125	2.75	1.09	6.87	5.76	2.75
213T					5.50											
215T	9.50	8.00	5.25	4.25	7.00	0.41	0.31	3.88	10.03	9.57	1.375	3.38	1.38	8.06	6.79	3.50

**Note:** Drawings shown are for reference only. Please contact Baldor for a detailed dimensional drawing of the specific motor you require. Drawings may also be available from our CD-ROM or website at [www.baldor.com](http://www.baldor.com)

## Dimensions

### Chemical Processing - Dirty Duty Motors Totally Enclosed, Fan-Cooled - NEMA 56C

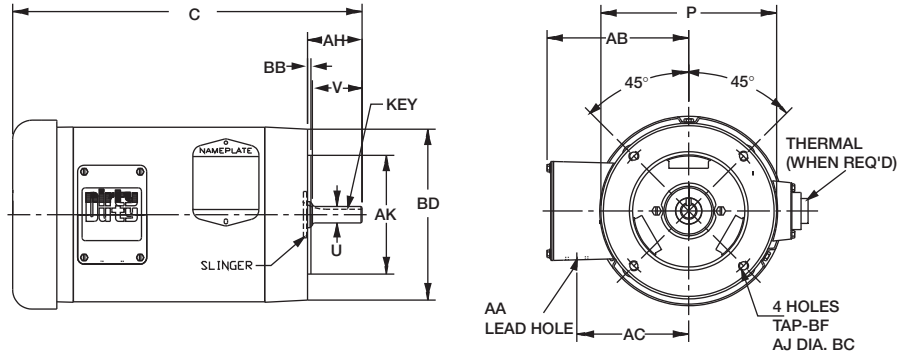

### Steel Band Construction

NEMA Frame	Key	P	U	V	AA	AB	AC	AH	AJ	AK	BB	BD	Tap BF
56C 1/2 - 1 Hp	0.19	5.69	0.625	1.87	0.50 NPT	4.51	3.53	2.06	5.88	4.50	0.12	5.81	3/8-16
56C 1-1/2 Hp	0.19	6.66	0.625	1.87	0.50 NPT	5.37	4.24	2.06	5.88	4.50	0.13	6.48	3/8-16

**Note:** Drawings shown are for reference only. Please contact Baldor for a detailed dimensional drawing of the specific motor you require. Drawings may also be available from our CD-ROM or website at [www.baldor.com](http://www.baldor.com)

## Dimensions

### Explosion-Proof-Horizontal Base and C-Face Mount Motors Totally Enclosed, Fan-Cooled NEMA 182T-182TC Through 365TC-405T Steel Band Construction

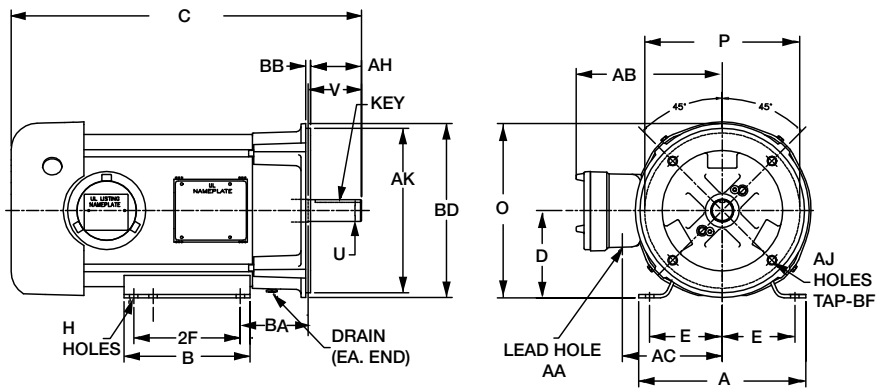
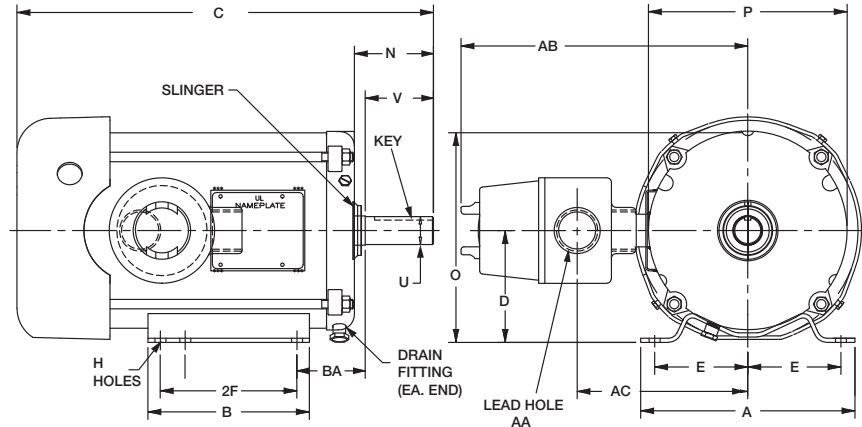

NEMA Frame	A	B	D	E	2F	H	N	O	P	U	V	AA	AB	AC	AH	AJ	AK	BA	BB	BD	Tap	
182T					4.50																	
184T	8.63	6.50	4.50	3.75	5.50	0.41	3.06	8.44	7.88	1.12	2.75	0.75	7.52	5.98	-	-	-	2.75	-	-	-	
182TC					4.50																	
184TC	8.63	6.50	4.50	3.75	5.50	0.41	-	8.99	8.00	1.12	2.75	1.00	7.54	5.16	2.62	7.25	8.50	3.50	0.25	8.98	1/2-13	
213T					5.50																	
215T	9.50	8.00	5.25	4.25	7.00	0.41	3.82	10.03	9.56	1.375	3.38	0.75	8.37	6.83	-	-	-	3.50	-	-	-	
213TC					5.50																	
215TC	9.50	8.00	5.25	4.25	7.00	0.41	-	10.03	9.69	1.37	3.37	1.00	12.21	7.53	3.12	7.25	8.50	4.25	0.25	9.04	1/2-13	

## Dimensions

### Explosion-Proof-Horizontal Base and C-Face Mount Motors Totally Enclosed, Fan-Cooled NEMA 182T-182TC Through 365TC-405T Cast Iron Construction

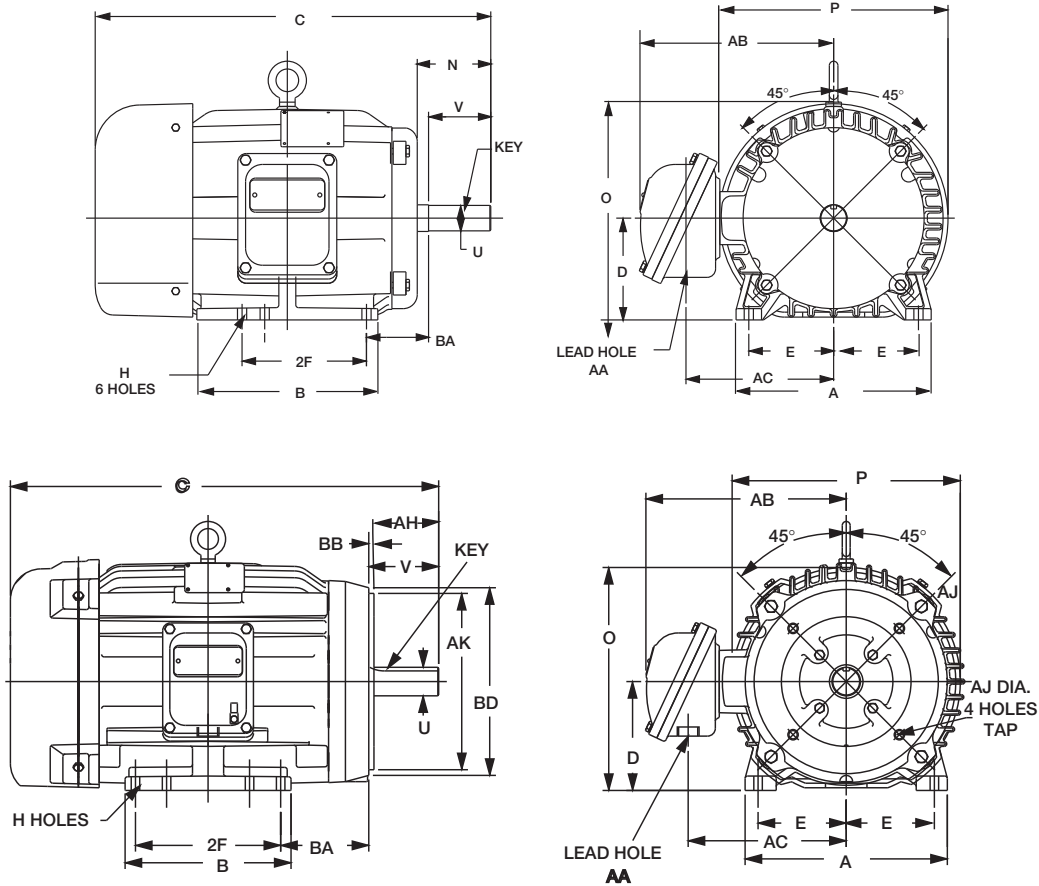

NEMA Frame	A	B	D	E	2F	H	N	O	P	U	V	AA	AB	AC	AH	AJ	AK	BA	BB	BD	Tap
213T					5.50																
215T	9.75	8.00	5.25	4.25	7.00	0.41	3.47	10.75	11.00	1.37	3.38	0.75	9.66	7.62	-	-	-	3.50	-	-	-
213TC					5.50																
215TC	9.75	8.00	5.25	4.25	7.00	0.41	-	10.75	11.84	1.37	3.38	0.75	9.66	7.62	3.12	7.25	8.50	4.50	0.25	9.05	1/2-13
254T					8.25																
256T	11.50	11.50	6.25	5.00	10.00	0.53	4.20	12.94	13.44	1.62	4.00	1.25	12.37	9.24	-	-	-	4.25	-	-	-
254TC					8.25																
256TC	11.50	11.50	6.25	5.00	10.00	0.53	-	12.94	13.44	1.62	4.00	1.25	12.38	9.24	3.75	7.25	8.50	4.75	0.25	9.13	1/2-13
284T					9.50																
286T	12.76	12.75	7.00	5.50	11.00	0.53	4.88	14.75	15.54	1.87	4.63	1.50	16.51	11.57	-	-	-	4.75	-	-	-
284TC					9.50																
286TC	12.76	12.75	7.00	5.50	11.00	0.53	-	14.75	15.54	1.87	4.63	1.50	16.38	11.43	4.38	9.00	10.50	4.75	0.25	11.23	1/2-13
324T					11.25																
326T	14.50	14.00	8.00	6.25	12.00	0.66	5.44	16.68	17.40	2.12	5.25	2.00	17.40	12.48	-	-	-	5.25	-	-	-
324TC					10.50																
326TC	14.50	14.00	8.00	6.25	12.00	0.66	-	16.68	17.39	2.12	5.25	2.00	17.43	12.48	5.00	11.00	12.50	5.25	0.25	13.38	5/8-11
364T		13.50			11.25																
365T	17.00	14.50	9.00	7.00	12.25	0.66	6.13	18.50	18.88	2.37	5.88	2.50	17.35	12.75	-	-	-	5.88	-	-	-
404T		15.25			12.75																
405T	19.50	1.75	10.00	8.00	13.75	0.81	7.56	21.00	20.88	2.87	7.25	2.50	18.44	13.75	-	-	-	6.62	-	-	-

**Note:** Drawings shown are for reference only. Please contact Baldor for a detailed dimensional drawing of the specific motor you require.

Drawings may also be available from our CD-ROM or website at [www.baldor.com](http://www.baldor.com)

## Dimensions

### P-Base Vertical Solid Shaft Pump - Cast Iron Construction Motors Totally-Enclosed, Fan-Cooled - NEMA 182LP Through 365VP

#### LP Style (Medium Thrust)

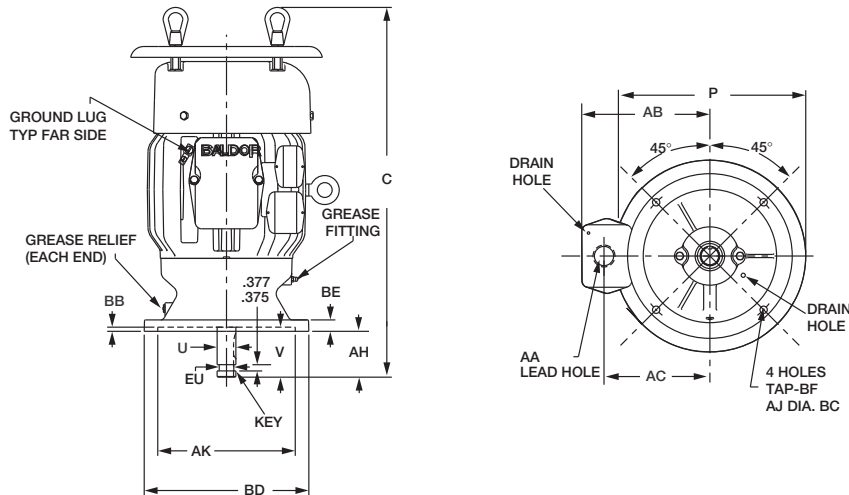

#### VP Style (High Thrust)

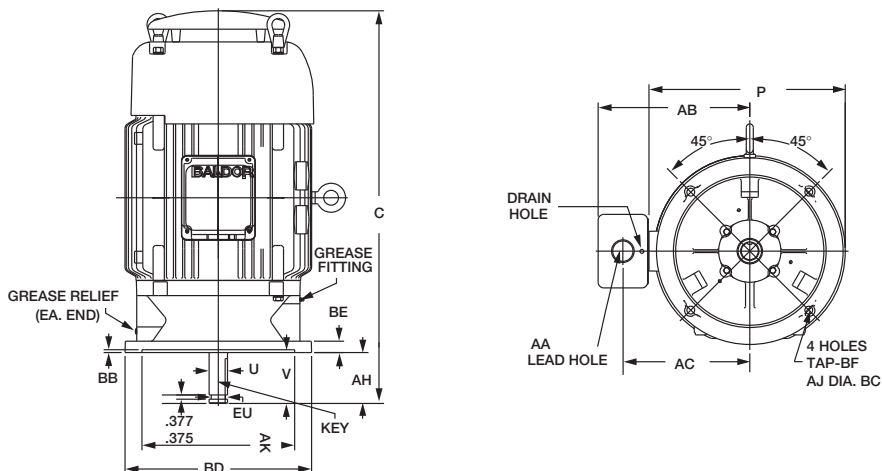

NEMA Frame	Key	P	R*	S*	U	V Min	AA	AB	AC	AH	AJ	AK	BB	BD	BE	Tap BF	EU
182LP							1.00										
184LP	0.25	11.50	0.984	0.25	1.125	3.00	NPT	7.69	6.35	2.75	9.12	8.25	0.25	9.88	0.68	0.44	0.875
213LP							1.50										
215LP	0.38	12.13	1.406	0.375	1.625	3.00	NPT	8.68	7.11	2.75	9.12	8.25	0.25	9.88	0.69	0.44	1.25
254LP							1.50										
256LP	0.38	12.94	1.406	0.375	1.625	3.00	NPT	9.50	8.07	2.75	9.12	8.25	0.25	9.87	0.69	0.44	1.25
284LP							2.00										
286LP	0.50	15.32	1.843	0.50	2.125	4.00	NPT	12.34	10.16	4.50	9.12	8.25	0.25	9.87	0.69	0.44	1.75
324LP							2.00										
326LP	0.50	17.35	1.843	0.50	2.125	4.00	NPT	13.41	11.22	4.50	14.75	13.50	0.25	16.50	1.00	0.69	1.75
324VP							2.00										
326VP	0.375	17.35	1.406	0.375	1.625	4.75	NPT	13.41	11.22	4.50	14.75	13.50	0.25	16.49	1.00	0.69	1.25
364VP							2.00										
365VP	0.38	19.25	1.406	0.375	1.625	4.75	NPT	14.37	12.13	4.50	14.75	13.50	0.25	16.49	1.00	0.69	1.25

**Note:**\* Please refer to Keyway Detail at the end of the AC section. Drawings shown are for reference only. Please contact Baldor for a detailed dimensional drawing of the specific motor you require. Drawings may also be available from our CD-ROM or website at [www.baldor.com](http://www.baldor.com)

## Connection Diagrams

### CD0005

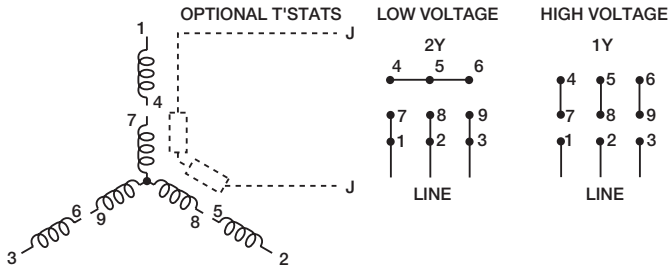

Notes:

1. Interchange any two line leads to reverse rotation.
2. Optional thermostats are provided when specified.
3. Actual number of internal parallel circuits may vary.
4. Lead colors are optional. Leads must be numbered as shown.

#### TYPICAL WYE-CONNECTED MOTOR

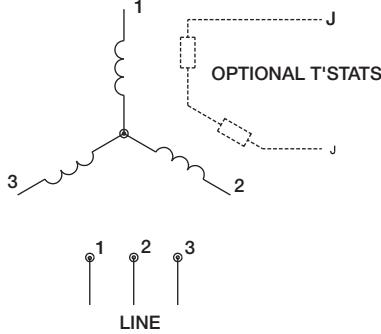

#### TYPICAL DELTA-CONNECTED MOTOR

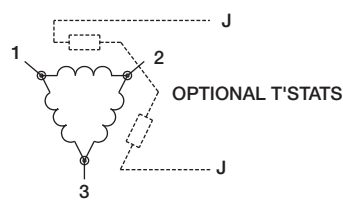

Notes:

1. Three lead motors may be designed as either wye-connected or delta-connected.
2. Interchange any two line leads to reverse rotation.
3. Optional thermostats are provided when specified.
4. Actual number of internal parallel circuits may vary.
5. Lead colors are optional. Leads must be numbered as shown.

### CD0022

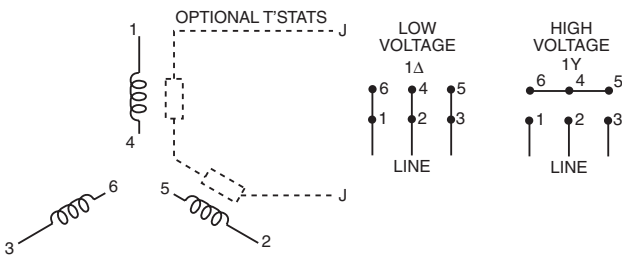

Notes:

1. Interchange any two line leads to reverse rotation.
2. Optional thermostats are provided when specified.
3. Actual number of internal parallel circuits may vary.
4. Lead colors are optional. Leads must be numbered as shown.

### CD0180

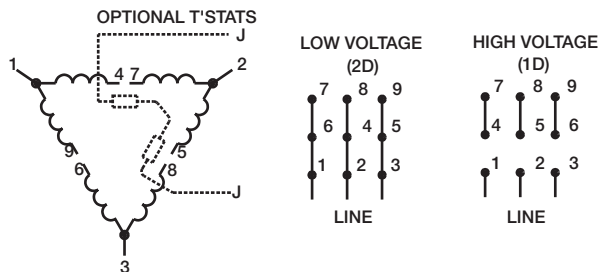

Notes:

1. Three lead motors may be designed as either wye-connected or delta-connected.
2. Interchange any two line leads to reverse rotation.
3. Optional thermostats are provided when specified.
4. Actual number of internal parallel circuits may vary.
5. Lead colors are optional. Leads must be numbered as shown.

# Connection Diagrams

## CD0382

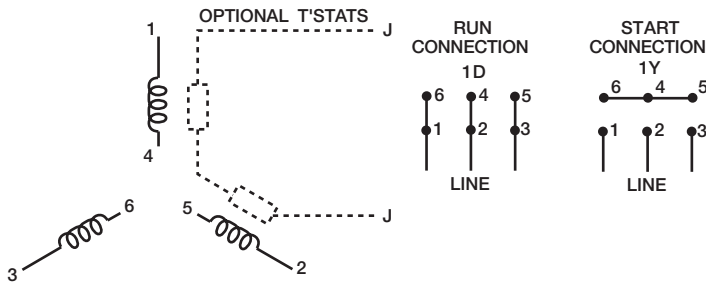

- Notes:
1. Interchange any two line leads to reverse rotation.
  2. Optional thermostats are provided when specified.
  3. Actual number of internal parallel circuits may vary.
  4. Lead colors are optional. Leads must be numbered as shown.
  5. For Across-The-Line starting, use "RUN" connection

## CD0695

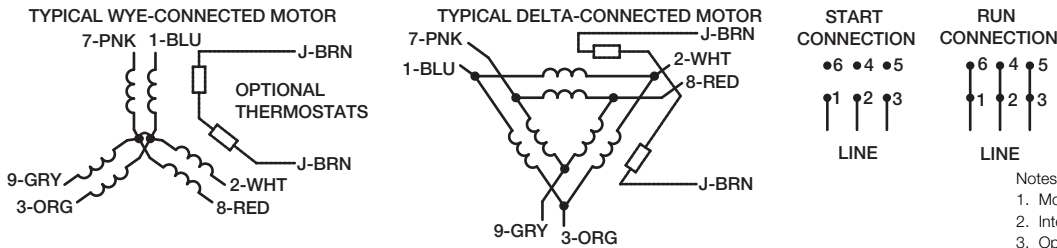

- Notes:
1. Motor may be wye-connected or delta-connected.
  2. Interchange any two line leads to reverse rotation.
  3. Optional thermostats are provided when specified.
  4. Actual number of internal parallel circuits may vary.
  5. Lead colors are optional. Leads must be numbered as shown.

## CD1071

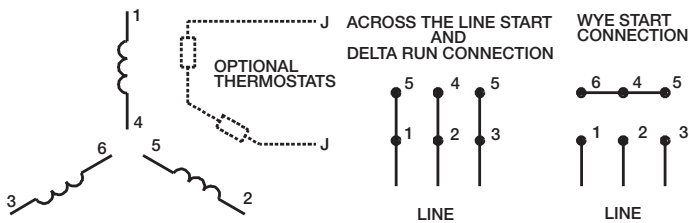

- Notes:
1. Interchange any two line leads to reverse rotation.
  2. Optional thermostats are provided when specified.
  3. Actual number of internal parallel circuits may vary.

## CD1435

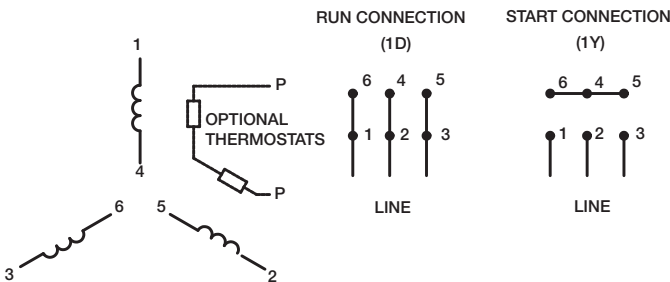

- Notes:
1. Interchange any two line leads to reverse rotation.
  2. Optional thermostats are provided when specified.
  3. Actual number of internal parallel circuits may vary.

## Contact your nearest Baldor District Office at these World Wide locations, or visit [www.baldor.com](http://www.baldor.com)

### UNITED STATES

#### ARIZONA

**PHOENIX**  
4211 S 43RD PLACE  
PHOENIX, AZ 85040  
PHONE: 602-470-0407  
FAX: 602-470-0464

#### CALIFORNIA

**LOS ANGELES**  
6480 FLOTILLA  
COMMERCE, CA 90040  
PHONE: 323-724-6771  
FAX: 323-721-5859

#### HAYWARD

21056 FORBES STREET  
HAYWARD, CA 94545  
PHONE: 510-785-9900  
FAX: 510-785-9910

#### COLORADO

**DENVER**  
2520 W BARBERRY PLACE  
DENVER, CO 80204  
PHONE: 303-623-0127  
FAX: 303-595-3772

#### CONNECTICUT

**WALLINGFORD**  
65 SOUTH TURNPIKE RD  
WALLINGFORD, CT 06492  
PHONE: 203-269-1354  
FAX: 203-269-5485

#### FLORIDA

**TAMPA/PUERTO RICO/  
VIRGIN ISLANDS**  
3906 EAST 11TH AVENUE  
TAMPA, FL 33605  
PHONE: 813-248-5078  
FAX: 813-247-2984

#### GEORGIA

**ATLANTA**  
62 TECHNOLOGY DR.  
ALPHARETTA, GA 30005  
PHONE: 770-772-7000  
FAX: 770-772-7200

#### ILLINOIS

**CHICAGO**  
1601 FRONTENAC ROAD  
NAPERVILLE, IL 60563  
PHONE: 630-848-5100  
FAX: 630-848-5110

#### INDIANA

**INDIANAPOLIS**  
5525 W. MINNESOTA ST  
INDIANAPOLIS, IN 46241  
PHONE: 317-246-5100  
FAX: 317-246-5110  
800-428-4141

### IOWA

#### DES MOINES

1901 BELL AVENUE, STE 7  
DES MOINES, IA 50315  
PHONE: 515-244-9996  
FAX: 515-244-6124

### MARYLAND

#### BALTIMORE

6660 SANTA BARBARA RD.  
SUITE 22-24  
ELK RIDGE, MD. 21075  
PHONE: 410-579-2135  
FAX: 410-579-2677

### MASSACHUSETTS

#### BOSTON

317 BROOKS ST.  
WORCESTER, MA 01606  
PHONE: 508-854-0708  
FAX: 508-854-0291

### MICHIGAN

#### DETROIT

33782 STERLING  
PONDS BLVD.  
STERLING HEIGHTS,  
MI 48312  
PHONE: 586-978-9800  
FAX: 586-978-9969

#### GRAND RAPIDS

668 3 MILE ROAD NW  
GRAND RAPIDS, MI 49504  
PHONE: 616-785-1784  
FAX: 616-785-1788

### MINNESOTA

#### MINNEAPOLIS

21080 134TH AVE. NORTH  
ROGERS, MN 55374  
PHONE: 763-428-3633  
FAX: 763-428-4551

### MISSOURI

#### ST LOUIS

422 INDUSTRIAL DRIVE  
MARYLAND HEIGHTS,  
MO 63043  
PHONE: 314-298-1800  
FAX: 314-298-7660

#### KANSAS CITY

915 N W PLATTE VALLEY DR  
RIVERSIDE, MO 64150  
PHONE: 816-587-0272  
FAX: 816-587-3735

### NEW YORK

#### AUBURN

ONE ELLIS DRIVE  
AUBURN, NY 13021  
PHONE: 315-255-3403  
FAX: 315-253-9923

### NORTH CAROLINA

#### GREENSBORO

1220 ROTHERWOOD RD  
GREENSBORO, NC 27406  
PHONE: 336-272-6104  
FAX: 336-273-6628

### OHIO

#### CINCINNATI

2900 EARHART COURT  
SUITE 200  
HEBRON, KY 41048  
PHONE: 859-586-0222  
FAX: 859-586-0779

#### CLEVELAND

8929 FREEWAY DRIVE  
MACEDONIA, OH 44056  
PHONE: 330-468-4777  
FAX: 330-468-4778

### OKLAHOMA

#### TULSA

2 EAST DAWES  
BIXBY, OK 74008  
PHONE: 918-366-9320  
FAX: 918-366-9338

### OREGON

#### PORTLAND

20393 SW AVERY COURT  
TUALATIN, OR 97062  
PHONE: 503-691-9010  
FAX: 503-691-9012

### PENNSYLVANIA

#### PHILADELPHIA

1035 THOMAS BUSCH  
MEMORIAL HIGHWAY  
PENNSAUKEN, NJ 08110  
PHONE: 856-661-1442  
FAX: 856-663-6363

#### PITTSBURGH

616H BEATTY ROAD  
MONROEVILLE, PA 15146  
PHONE: 412-380-7244  
FAX: 412-380-7250

### TENNESSEE

#### MEMPHIS

4000 WINCHESTER ROAD  
MEMPHIS, TN 38118  
PHONE: 901-365-2020  
FAX: 901-365-3914

### TEXAS

#### HOUSTON

4647 PINE TIMBERS  
SUITE # 135  
HOUSTON, TX 77041  
PHONE: 713-895-7062  
FAX: 713-690-4540

### DALLAS

3040 QUEBEC  
DALLAS, TX 75247  
PHONE: 214-634-7271  
FAX: 214-634-8874

### ODESSA

6968 EAST COMMERCE  
ODESSA, TX 79762  
PHONE: 432-367-2707  
FAX: 432-367-9877

### UTAH

#### SALT LAKE CITY

2230 SOUTH MAIN STREET  
SALT LAKE CITY, UT 84115  
PHONE: 801-832-0127  
FAX: 801-832-8911

### WISCONSIN

#### MILWAUKEE

2725 SOUTH 163RD ST  
NEW BERLIN, WI 53151  
PHONE: 262-784-5940  
FAX: 262-784-1215

### INTERNATIONAL SALES

#### FORT SMITH, AR

BALDOR ELECTRIC CO  
FORT SMITH, AR 72902  
PHONE: 479-646-4711  
FAX: 479-648-5895

### CANADA

#### EDMONTON, ALBERTA

4053-92 STREET  
EDMONTON, ALBERTA  
T6E6R8  
PHONE: 780-434-4900  
FAX: 780-438-2600

#### OAKVILLE, ONTARIO

2750 COVENTRY ROAD  
OAKVILLE, ONTARIO  
L6H6R1  
PHONE: 905-829-3301  
FAX: 905-829-3302

#### MONTREAL, QUEBEC

1844 WILLIAM STREET  
MONTREAL, QUEBEC  
H3J1R5  
PHONE: 514-933-2711  
FAX: 514-933-8639

#### VANCOUVER,

#### BRITISH COLUMBIA

1538 KEBET WAY  
PORT COQUITLAM, BC  
V3C 5M5  
PHONE: 604-421-2822  
FAX: 604-421-3113

### WINNIPEG, MANITOBA

54 PRINCESS STREET  
WINNIPEG, MANITOBA  
R3B1K2  
PHONE: 204-942-5205  
FAX: 204-956-4251

### AUSTRALIA

UNIT 3, 6 STANTON ROAD  
SEVEN HILLS, NSW 2147,  
AUSTRALIA  
PHONE: (61) (2) 9674 5455  
FAX: (61) (2) 9674 2495

UNIT 8, 5 KELLETTS ROAD  
ROWVILLE, VICTORIA, 3178  
AUSTRALIA

PHONE: (03) 9753 4355  
FAX: (03) 9753 4366

### CENTROAMERICA

RESIDENCIAL PINARES DE  
SUIZA POL. 15 #44, NVA.  
SAN SALVADOR  
EL SALVADOR, CENTRO  
AMERICA

PHONE: (503) 288-1519  
FAX: (503) 288-1518

### BALDOR SUDAMERICA

9109 0818, ZONA 6  
BETHANIA  
PANAMA CITY,  
REP. DE PANAMA  
PHONE: (507) 261-5347  
FAX: (507) 261-5355

### CHINA

SHANGHAI JIAHUA  
BUSINESS CENTER  
ROOM NO. C-203  
808 HONG QIAO ROAD  
SHANGHAI 200021  
PHONE: 86-21-64473060  
FAX: 86-21-64078620

### GERMANY

DIESELSTRASSE 22  
D-85551 KIRCHHEIM  
MUNICH, GERMANY  
PHONE: (49) (89) 90508 - 0  
FAX: (49) (89) 90508 - 491

### ITALY

BALDOR ASR AG  
MENDRISIO OFFICE  
VIA BORROMINI, 20A  
6850 MENDRISIO  
SWITZERLAND  
PHONE: 0041 91 640 99 50  
FAX: 0041 91 630 26 33

### JAPAN

DIABLDG 802,  
2-21-1 TSURUYA-CHO,  
KANAGAWA-KU  
YOKOHAMA, 221-0835,  
JAPAN  
PHONE: 81-45-412-4506  
FAX: 81-45-412-4507

### KOREA

ROOM 210  
BUPYEONG INDUSTRIAL  
COMMERCIAL COOP.  
396-13 CHEONGCHEON  
2-DONG, BUPYEONG-GU  
INCHEON, KOREA, 403-858  
PHONE: 82-32-508-3252  
FAX: 82-32-508-3253

### MEXICO

BLVD. AL AEROPUERTO,  
KM. 2  
LEÓN 37545,  
GUANAJUATO, MÉXICO  
PHONE: 52-477-761-2030  
FAX: 52-477-761-2010

### SINGAPORE

51 KAKI BUKIT ROAD 2  
K B WAREHOUSE  
COMPLEX  
SINGAPORE 417863  
PHONE: (65) 6 744 2572  
FAX: (65) 6 747 1708

### SWITZERLAND

POSTFACH 73  
SCHUTZENSTRASSE 59  
CH-8245 FEUERTHALEN  
SWITZERLAND  
PHONE: (41) (52) 6474700  
FAX: (41) (52) 6592394

### TAIWAN

ROOM R, 2F, NO. 124  
CHUNG CHENG ROAD,  
SHIH-LIN DIST.  
TAIPEI 11141  
PHONE: 886-2-2835-1666  
EXT. 802  
FAX: 886-2-2835-1717

### UNITED KINGDOM

6 BRISTOL DISTRIBUTION  
PARK  
HAWKLEY DRIVE  
BRISTOL BS32 0BF U.K.  
PHONE: 44 1454 850000  
FAX: 44 1454 859001

Baldor Electric Company  
P.O. Box 2400  
Fort Smith, AR 72902-2400 U.S.A.  
Ph (479) 646-4711 • Fax (479) 648-5792  
International Fax (479) 648-5895  
[www.baldor.com](http://www.baldor.com)

