

# CONTENTS

## TORQUE-TAMER™

Features / Benefits .....	PT5-2
Specification .....	PT5-3
How To Order .....	PT5-3
Nomenclature .....	PT5-3
Selection/Dimensions .....	PT5-4
Part Number Index .....	INDEX-1
Keyword Index .....	INDEX-67

# FEATURES/BENEFITS

## TORQUE-TAMER

### DODGE TORQUE-TAMER Clutches

Low cost overload protection that's a cinch to adjust.

Intermittent shock loads or drive overload conditions can stress reducers to a point of premature failure. DODGE TORQUE-TAMER clutches provide a simple, economical solution. When an overload occurs, the TORQUE-TAMER clutch is designed to slip, protecting the valuable reducer and other components in the drive train. Once the overload is cleared, the TORQUE-TAMER clutch automatically picks up the load.

A DODGE TORQUE-TAMER clutch is easily set to the required slip-protection torque level, using standard wrenches.

### QUALITY FEATURES

- Non-asbestos friction discs
- Long-life bushing

New keyed bushing will not slip on the hub. Provides improved bearing surface for sprocket to ride on during overload slip. NOTE: Because of the possibility of excessive heat build-up, the TORQUE-TAMER clutch is not recommended for continuous slip duty.

### EXCLUSIVE "EASY SET" ADJUSTMENT

Torque adjustment is a simple matter, accomplished quickly! The need for hammer and block, brute strength and spanner wrenches is eliminated. No sweat. No wasted time.

For maximum torque, tighten the adjusting nut to finger tight and use a small wrench to tighten the three cap screws until the heads bottom out. For less torque, loosen the cap screws and set screws. Then back off the adjusting nut from one to seven spline notches, depending on the torque desired. Then retighten set screw and cap screws. Please consult Instruction Manual (MN4038) for complete details. This Instruction Manual is available on [www.dodge-pt.com](http://www.dodge-pt.com).

### AUTOMATIC RESET

The DODGE TORQUE-TAMER clutch gives machinery permanent protection against overloads during starting, reversing or driving-by slipping at the desired load.

When an overload occurs, the driven member slips between long-life, clutch-type friction discs. After slipping has started, it will continue at approximately 90% of the torque setting, due to the lower coefficient of friction when slipping, until the overload condition has been corrected. It resumes driving without resetting when the overload is relieved.

For speeds above 500 rpm please consult Dodge Engineering at 864-284-5700

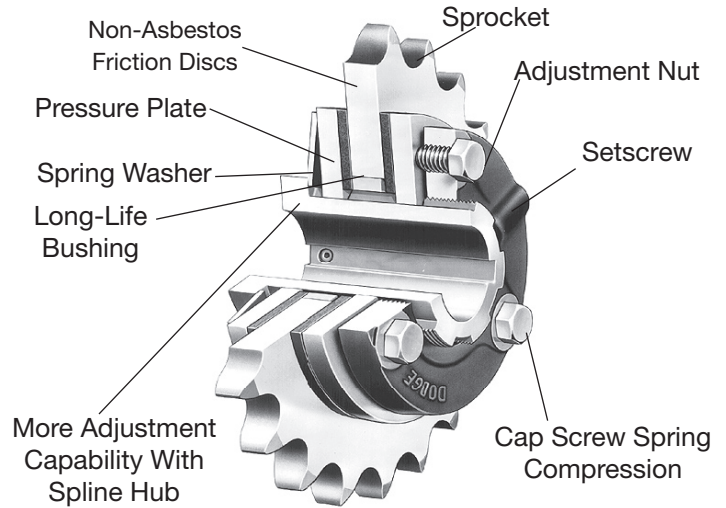

### HIGHER TORQUE RATINGS

Spring design provides higher torque ratings for No. 35 and No. 50 TORQUE-TAMER clutches. This results in more uniform coverage between minimum and maximum torque range of the TORQUE-TAMER clutch.

### APPLICATION VERSATILITY

DODGE TORQUE-TAMER clutches may be used with stock or special sprockets, gears, sheaves, flange or other driven members. It is recommended that the rubbing sides of the driven member be ground to provide a smooth rubbing surface of 65 to 125 micro-inches.

Higher torque ratings can be obtained by the use of a second spring nested within the original spring. (See torque rating table on page PT5-4.)

### MINIMUM MAINTENANCE

The DODGE TORQUE-TAMER clutch is simple in design, compact, efficient, and built for long life. It provides low cost torque limiting service for a wide variety of applications. No lubrication. . . minimum maintenance.

TORQUE-TAMER clutches are supplied complete with friction discs and one spring. The following are ordered separately:

**SPROCKET**-Stock sizes shown on page PT5-6. Non-stock sizes can be furnished as reworked A-Plate sprockets listed in the sprocket section of the DODGE Engineering Catalog.

**BUSHINGS**-Specify size and width and/or part no. as tabulated.

**EXTRA SPRING**-Provides higher torque rating as tabulated. Second spring is nested into first spring.

## TORQUE-TAMER

### SPECIFICATION

The DODGE TORQUE-TAMER is a protective device that is designed to slip when overloaded, thus protecting the valuable reducer and other components in the drive train. Once the overload is cleared, the TORQUE-TAMER clutch will automatically re-engage. No resetting is required.

### HOW TO ORDER

TORQUE-TAMER clutches are ordered by the size of the TORQUE-TAMER, the bore size of the unit, and the sprocket and bushing width required. The DODGE TORQUE-TAMER is supplied with the friction discs and one spring. The sprocket, bushings, and additional spring (if needed) must be ordered separately.

### NOMENCLATURE

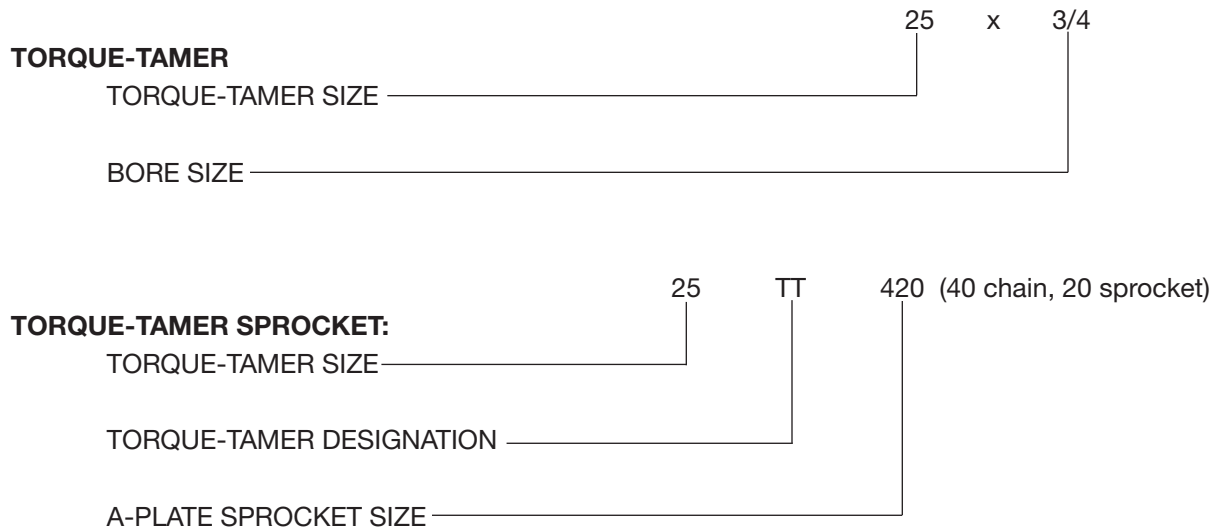



# SELECTION/DIMENSIONS

## TORQUE-TAMER

**STEP 1:** Determine torque at which clutch should limit or slip.

$$T = \frac{HP \times 63025}{RPM} \times \text{Limit Factor}$$

Limit factor determines point at which TORQUE-TAMER should slip above nominal load.

**STEP 2:** Refer to Chart 1. Select the TORQUE-TAMER size that falls within the min./max torque range. Verify the max bore for the TORQUE-TAMER is within specification. This chart will also determine the number of springs required and the spline setting for the TORQUE-TAMER.

**STEP 3:** Refer to Chart 2 to verify the minimum number of sprocket teeth required for the TORQUE-TAMER sprocket. From Chart 2, also determine the bushing width required.

**EXAMPLE:** 3HP, RPM at TORQUE-TAMER 175, Needs TORQUE-TAMER to limit or slip at 150% of nominal torque.

- Limit factor is 150%/100%=1.5

$$T = \frac{3HP \times 63025}{175 \text{ RPM}} \times 1.5 = 1,620 \text{ lb-in}$$

- Select size from Chart 1. Minimum size is #35 TORQUE-TAMER. One spring will be sufficient, however, a second spring can be added for increased torque capability (should parameters of application required additional torque).

**Chart 1 -**

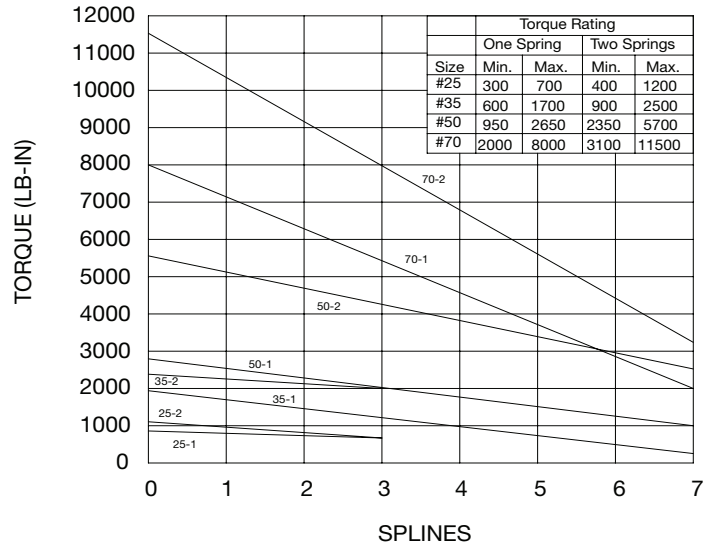

**Note**

Graph indicates approximate rated torque vs. number of splines adjusting nut is backed off from finger tight.

Numbers on calibration lines indicate TORQUE-TAMER model and quantity of compression springs. Example: 35-2 is a model 35 TORQUE-TAMER with 2 springs.

- Check Chart 2 for maximum bore and minimum sprocket teeth and bushing requirements.

**CHART 2 - Minimum Allowable Sprocket Teeth• & Width of Bushing Required & Maximum Bore Capability**

TORQUE-TAMER Size	Data:	Chain SizeŽ										Max Bore	
		#35 Chain	#41 Chain	#40 Chain	#50 Chain	#60 Chain	#80 Chain	#100 Chain	#120 Chain	#140 Chain	#160 Chain	Std. KW†	Shallow KW†
25	Minimum # Teeth	25	19▲	19▲	16▲	.....	.....	.....	.....	.....	.....	7/8	1
	Bushing Width Req'd	1/8	1/8	1/4	1/4	.....	.....	.....	.....	.....	.....		
35	Minimum # Teeth	34	26	26	21	18	15	.....	.....	.....	.....	1-3/16	1-1/4
	Bushing Width Req'd	1/8	1/8	1/4	1/4	3/8	3/8	.....	.....	.....	.....		
50	Minimum # Teeth	48	35	35	30	25	19	17	.....	.....	.....	1-3/16	2
	Bushing Width Req'd	1/8	1/8	1/4	1/4	3/8	3/8	1/2***	.....	.....	.....		
70	Minimum # Teeth	.....	.....	48	40	34	26	21	18	16	14	2-3/4	3
	Bushing Width Req'd	.....	.....	1/4	1/4	3/8	3/8	1/2	3/4*	3/4*	1**		

- Minimum number of teeth on sprocket which will permit chain to clear friction disc
- ▲ 20 teeth minimum recommended. Minimal clearance of 19 teeth may shorten life

- \* Use two 3/8" wide bushings
- \*\* Use two 1/2" wide bushings
- † Keyway to be cut central with threaded spline. For standard KW sizes refer to page PT1-74.
- \*\*\* Use two 1/4" wide bushings

FEATURES/BENEFITS PAGE PT5-2	SPECIFICATION/HOW TO ORDER PAGE PT5-3		
---------------------------------	--	--	--

# SELECTION/DIMENSIONS

## TORQUE-TAMER

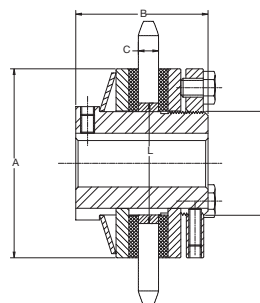
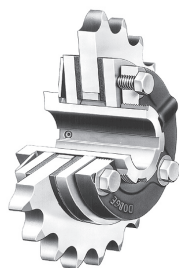

**TORQUE-TAMER Clutch Dimensions**

TORQUE-TAMER Size	Avg. Wt.	A	B	C		K	L	Max. Bore	
				Min.	Max.			Std. Key*	Shallow Key*
25	1	2-1/2	1-3/4	1/8	11/32	1.368	1.628	7/8	1
35	2.5	3-1/2	2-7/16	1/8	5/8	1.675	2.003	1-3/16	1-1/4
50	6	5	2-7/8	1/8	5/8	2.625	3.005	1-3/4	2
70	18	7	3-7/8	1/4	1-1/4	3.811	4.194	2-3/4	3

\* Keyway to be cut central with threaded spline.

### Stock TORQUE-TAMER Clutches: Finished Bores & Reborable

#### Stock TORQUE-TAMER Clutches w/Finished Bore & Keyway

#### Reborable TORQUE-TAMER Clutches

TORQUE-TAMER Size	Finished Bore		Reborable		
	Bore	Part Number	Bore (No KW & 1 ▲)	Part Number	Max Bore
					Standard KW*      Shallow KW*
25	1/2	096034	1/2	096033	7/8      1
	5/8	096035			
	3/4	096036			
	7/8	096037			
35	3/4	096008	3/4	096010	1-3/16      1-1/4
	7/8	096009			
	1	096011			
50	1	096014	1	096017	1-3/4      2
	1-1/8	096015			
	1-3/16	096018			
	1-1/4	096019			
	1-3/8	096020			
	1-7/16	096021			
	1-1/2	096022			
1-5/8	096023				
70	1-7/16	096028	1-3/8	096027	2-3/4      3
	1-1/2	096029			
	1-3/4	096030			
	1-15/16	096031			
	2	096032			
	2-3/16	096038			
2-7/16	096016				

▲ With standard Keyway and (1) Setscrew.

\* Keyway to be cut central with threaded spline. For standard KW sizes refer to page PT1-74.

FEATURES/BENEFITS PAGE PT5-2	SPECIFICATION/HOW TO ORDER PAGE PT5-3		
---------------------------------	--	--	--

# SELECTION/DIMENSIONS

## TORQUE-TAMER TORQUE-TAMER Sprocket

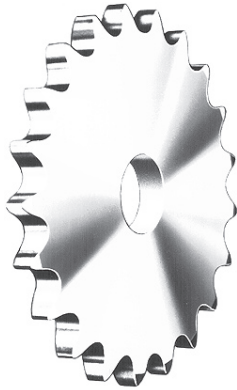

Stock TORQUE-TAMER sprockets are bored to fit TORQUE-TAMER clutches. Sprocket faces are machined smooth and parallel to provide proper interface with friction discs. Rubbing sides are micro ground to 65 to 125 micro-inches.

Standard A-Plate sprockets can also be reworked for use with TORQUE-TAMER clutches. Refer to DODGE List price Book for modifications charges.

### Stock TORQUE-TAMER Sprockets Bored and Micro Ground

#25 TORQUE-TAMER					#35 TORQUE-TAMER				
Chain Size	No. Teeth	Descrip.	Part No	Bushing Part No *	Chain Size	No. Teeth	Descrip.	Part No	Bushing Part No *
40	19	25TT419	096135	096051	40	26	35TT426	096150	096056
40	20	25TT420	096136	096051	50	21	35TT521	096151	096056
40	21	25TT421	096137	096051	50	22	35TT522	096152	096056
40	23	25TT423	096138	096051	50	23	35TT523	096153	096056
50	16	25TT516	096139	096051	50	25	35TT525	096154	096056
50	17	25TT517	096140	096051	60	18	35TT618	096155	096057
50	18	25TT518	096141	096051	60	19	35TT619	096156	096057
50	19	25TT519	096142	096051	60	20	35TT620	096157	096057
50	21	25TT521	096143	096051	60	21	35TT621	096158	096057
50	23	25TT523	096144	096051	60	23	35TT623	096159	096057
#50 TORQUE-TAMER					#70 TORQUE-TAMER				
Chain Size	No. Teeth	Descrip.	Part No	Bushing Part No *	Chain Size	No. Teeth	Descrip.	Part No	Bushing Part No *
50	30	50TT530	096165	096063	60	35	70TT635	096175	096071
60	25	50TT625	096166	096064	80	26	70TT826	096176	096071
60	26	50TT626	096167	096064	80	27	70TT827	096177	096071
80	19	50TT819	096168	096064	100	21	70TT1021	096178	096072
80	20	50TT820	096169	096064	100	22	70TT1022	096179	096072
80	21	50TT821	096170	096064					
80	23	50TT823	096171	096064					

\* Bushing Ordered Separately

### TORQUE-TAMER Clutch Extra Items

TORQUE-TAMER Size	Part Number for Bushing Width of:				Part Number for Extra Spring
	1/8"	1/4"	3/8"	1/2"	
25	096050	096051	.....	.....	096039
35	096055	096056	096057	.....	096041
50	096062	096063	096064	.....	096042
70	.....	096070	096071	096072	096043
Reference#	22				16

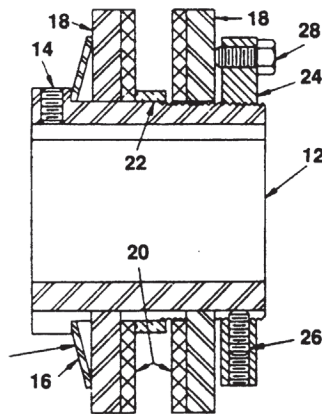

WHEN 2 SPRINGS ARE TO BE USED, INSTALL BOTH HERE

### TORQUE-TAMER Replacement Parts

Reference#	No. Req'd	Name of Part	Part Numbers			
			Size 25	Size 35	Size 50	Size 70
12	1	Hub Assembly	N/A	N/A	N/A	N/A
14	1	Hub Set Screw	N/A	N/A	N/A	N/A
18	2	Pressure Plate	391371	391375	391379	391383
20	1	• Friction Discs	096065	096066	096067	096068
24	1	Adjusting Nut Assembly	391372	391376	391380	391384
26	1	▲ Adjusting Nut Set Screws	.....	.....	.....	.....
28	3	▲ Tension Screw	391373	391377	391381	391385

- Sold in packs of 2 only
- ▲ Included in preceding assembly