

CONTENTS



Fluid Coupling

Features/Benefits	PT4-2
Nomenclature	PT4-3
Selection	PT4-3
Selection/Dimensions	
Fluid Coupling Drives - KSD	PT4-4
Fluid Coupling Drives - KCM	PT4-6
Fluid Coupling Drives - KCP	PT4-8
Part Number Index	INDEX-1
Keyword Index	INDEX-67



FEATURES/BENEFITS

Fluid Coupling

- **Smoother and Shock Free Operation**
 - Motor starts under no load conditions
 - Smoother starts
- **More Efficient Design**
 - Permits use of standard NEMA Design B motors
 - Eliminate need for motors with special winding
 - Wound rotor motors not needed
- **Overload Protection**
 - Provides overload protection at overloads somewhat greater than starting torque
 - Protection devices to prevent damage to Fluid Couplings are available
- **Low Current Draw**
 - Less than twice the nameplate amperage during both starting and overload periods
 - Many electric utilities recommend Fluid Couplings
- **Increased Productivity**
 - Eliminates product spillage and machine damage due to harsh starts or jammed loads

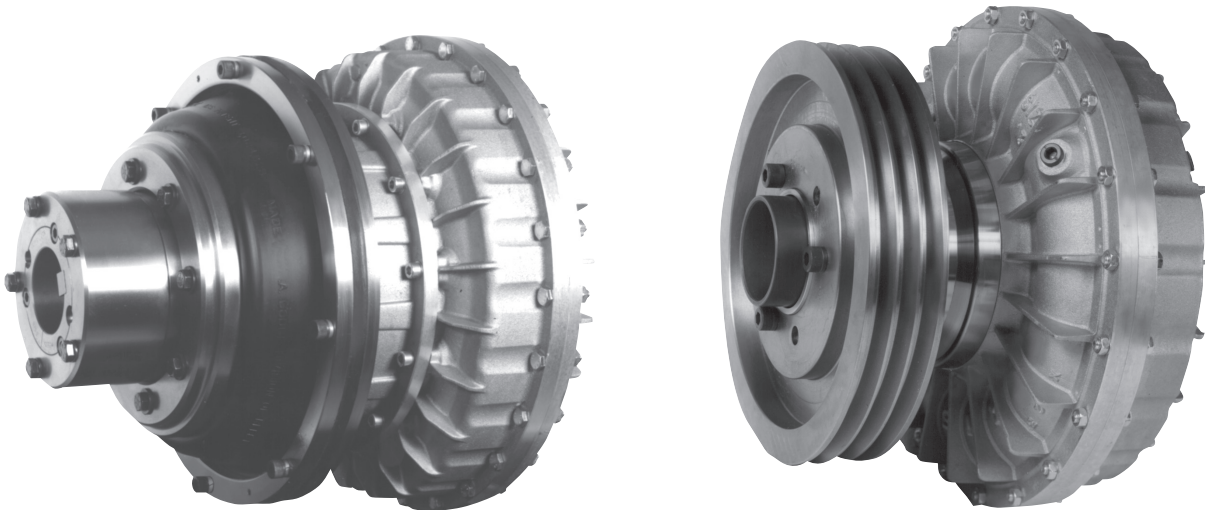



NOMENCLATURE

Fluid Coupling

NOMENCLATURE

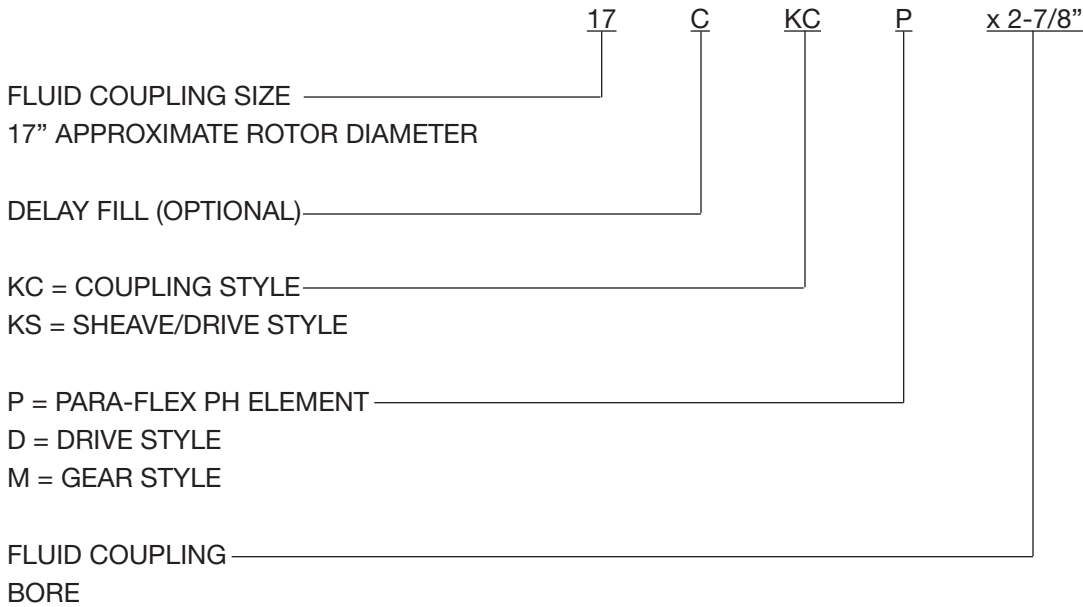

SELECTION

Fluid Coupling

Fluid Coupling Selection

HP	RPM		
	1800	1500	1200
5	8	8	9
7.50	8	9	11
10	8	9	12
15	9	11	12
20	11	12	13
25	11	12	13
30	11	12	15
40	12	13	15
50	13	15	17
60	13	15	17
75	15	15	17
100	15	17	19
125	17	19	21
150	17	19	21
200	19	21	24
250	21	21	24
300	21	24	27
350	21	24	27
400	24	24	27
500	24	27	29



SELECTION/DIMENSIONS

Fluid Coupling

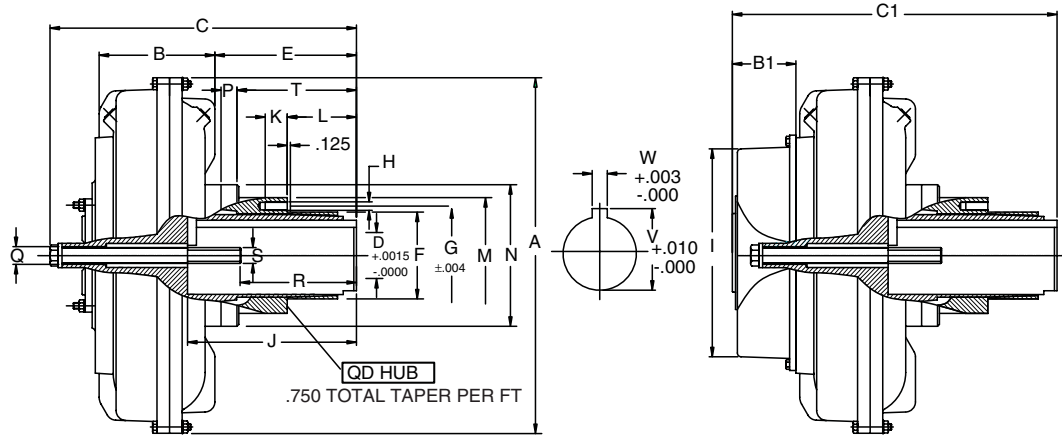

KSD-QD

CKSD-QD

Dimensional Data Sheet - KSD & CKSD

Size	D Bore	A	KSD		CKSD		E	F	G	H		J	K	L	M	N	P	Q	R	S	T	QD Hub Size	Weight (lb) Less Oil		Oil U.S. Gal. max.	
			B	B1	C Max	C1 Max				#	Dia												KSD-QD	CKSD-QD	KSD-QD	CKSD-QD
			7	1.375• 1.125 0.875	8.98	3.03					7.09												-	2.77	2.19	2.69
8	1.375• 1.125	10.08	3.58		7.33	-	2.61	2.19	2.69	3	1/4-20	2.40	0.6	1.2	3.1	4.5	0.6	1/2-13 UNC			1.94	SDS	14.8		0.40	
9	1.625• 1.375	11.61	3.78		9.80	-	3.98	2.81	3.31	3	5/16-18	3.31	0.7	1.5	3.9	5.0	1.0	3/4-10 UNC			2.48	SK	28.7		0.52	
11	1.875• 1.625	12.80	4.21		10.20	11.39	3.86	3.13	3.88	3	3/8-16	4.00	0.8	1.5	4.6	5.5	0.8	3/4-10 UNC			2.76	SF	34.2		0.73	
12	2.125• 1.875 1.625	14.57	4.80	3.15	11.56	13.05	5.10	3.83	5.00	3	1/2-13	4.25	1.1	1.9	6.0	6.1	0.9	3/4-10 UNC			3.98	E	50.7	57.2	1.08	1.27
13	2.375• 2.125 1.875	15.67	5.39	3.15	13.90	14.96	6.42	3.83	5.00	3	1/2-13	4.25	1.1	2.8	6.0	7.0	1.1	3/4-10 UNC			5.22	E	73.9	80.5	1.37	1.53
15	2.875• 2.375	18.11	5.95	3.62	15.60	16.70	7.13	4.44	5.63	3	9/16-12	7.00 5.63	1.2	3.9	6.6	8.0	1.38	7/8-9 UNC	5.35 3.90	3/4-10 UNC	5.43	F	107	115.8	2.02	2.27
17	3.375• 2.875	20.47	6.69	3.98	19.11	20.32	9.65	5.15	6.25	3	5/8-11	8.25 7.00	1.4	4.3	7.24	8.3	2.8	1 1/4-7 UNC	6.30 5.00	7/8-9 UNC	6.69	J	156	169.2	3.09	3.59
19	3.375• 2.875	22.24	7.48	3.98	18.17	20.32	8.86	5.15	6.25	3	5/8-11	8.25 7.00	1.4	4.3	7.24	8.98	1.77	1 1/8-7 UNC	6.30 5.00	7/8-9 UNC	6.69	J	174	187.2	3.75	4.36
21	3.875• 3.375	24.41	8.07	4.53	21.46 19.88	24.41 22.84	11.81 10.24	6.50	7.88	4	3/4-10	1.00 0.88	1.6	7.1 5.5	9.02	10.38	2.2	1 1/4-7 UNC	6.56 6.51	7/8-9 UNC	11.02 9.45	M	270	292	5.02	6.08
24	3.875•	27.95	9.02	4.53	21.46	24.41	10.87	6.50	7.88	4	3/4-10	1.00	1.6	7.1	9.02	10.38	1.4	1 1/4-7 UNC	6.56	7/8-9 UNC	11.02	M	307	329	7.50	8.24

• Max Bore



SELECTION/DIMENSIONS

Fluid Coupling

Part Numbers

KSD Drive Accepts "Q" Style Sheave	
Part #	Part Description
118780	7 KSD-QD SDS W/ 1-1/8 COLLET
118781	8 KSD-QD SDS W/ 1-1/8 COLLET
118782	9 KSD-QD SK W/ 1-3/8 COLLET
118783	11 KSD-QD SF W/ 1-7/8 COLLET
118784	12 KSD-QD E W/ 2-1/8 COLLET
118785	13 KSD-QD E W/ 2-1/8 COLLET
118786	13 KSD-QD E W/ 2-3/8 COLLET
118648	15 KSD-QD F W/ 2-3/8 COLLET
118649	15 KSD-QD F W/ 2-7/8 COLLET
118650	17 KSD-QD J W/ 3-3/8 COLLET
118651	19 KSD-QD J W/ 3-3/8 COLLET
118652	21 KSD-QD M W/ 3-3/8 FINISH BORE
118653	24 KSD-QD M W/ 3-3/8 FINISH BORE

Delay Fill

CKSD Drive Accepts "Qd" Style Sheave	
Part #	Part Description
118654	11 CKSD-QD SF W/ 1-7/8 COLLET
118655	12 CKSD-QD E W/ 2-1/8 COLLET
118656	13 CKSD-QD E W/ 2-1/8 COLLET
118657	13 CKSD-QD E W/ 2-3/8 COLLET
118658	15 CKSD-QD F W/ 2-3/8 COLLET
118659	15 CKSD-QD F W/ 2-7/8 COLLET
118660	17 CKSD-QD J W/ 3-3/8 COLLET
118661	19 CKSD-QD J W/ 3-3/8 COLLET
118662	21 CKSD-QD M W/ 3-3/8 FINISH BORE
118663	24 CKSD-QD M W/ 3-3/8 FINISH BORE

KSD Drive Accepts Bolt-On Style Sheave	
Part #	Part Description
118787	15 KSD FLUID CPLG W/ 2-3/8 F.B.
118788	15 KSD FLUID CPLG W/ 2-7/8 F.B.
118789	15 KSD FLUID CPLG 2-3/8 COLLET
118790	15 KSD FLUID CPLG 2-7/8 COLLET
118792	17 KSD FLUID CPLG W/ 3-3/8 F.B.
118793	17 KSD FLUID CPLG 3-3/8 COLLET
118794	17 KSD FLUID CPLG 2-3/8 COLLET
118795	19 KSD FLUID CPLG W/ 3-3/8 F.B.
118796	19 KSD FLUID CPLG 3-3/8 COLLET
118797	21 KSD FLUID CPLG W/ 3-3/8 F.B.
118798	24 KSD FLUID CPLG W/ 3-3/8 F.B.

The motor shaft for sizes 15 KSD F.B. style and up must be tapped.

* For non-standard sheaves contact DODGE Drive Components.



Collet Mount: Available on most sizes for ease of installation.

KSD Bolt-On Sheaves *		
Part Number	KSD#	Description
118740	15	3GR 5V 12.5
118743	15	4GR 5V 9.75
118744	15	4GR 5V 10.3
118745	15	4GR 5V 10.9
118746	15	4GR 5V 11.3
118747	15	4GR 5V 11.8

KSD Bolt-On Sheaves *		
Part Number	KSD#	Description
118750	17	4GR 5V 12.5
118755	17	5GR 5V 10.9
118746	17	5GR 5V 11.3
118757	17	5GR 5V 11.8
118758	17	5GR 5V 12.5
118759	17	5GR 5V 13.2
118762	17	6GR 5V 10.9
118763	17	6GR 5V 11.3
118749	17	4GR 5V 11.8
118764	19	6GR 5V 12.5
118765	19	6GR 5V 13.2
118769	19	8GR 5V 10.9
118770	19	8GR 5V 11.3
118771	19	8GR 5V 11.8
118772	21	5GR 8V 14.0
118774	21	6GR 8V 13.2
118775	21	6GR 8V 14.0
118776	21	8GR 8V 13.2
118777	21	8GR 8V 14.0
118778	24	8GR 8V 14.0
118779	24	10GR 8V 13.2



SELECTION/DIMENSIONS

Fluid Coupling

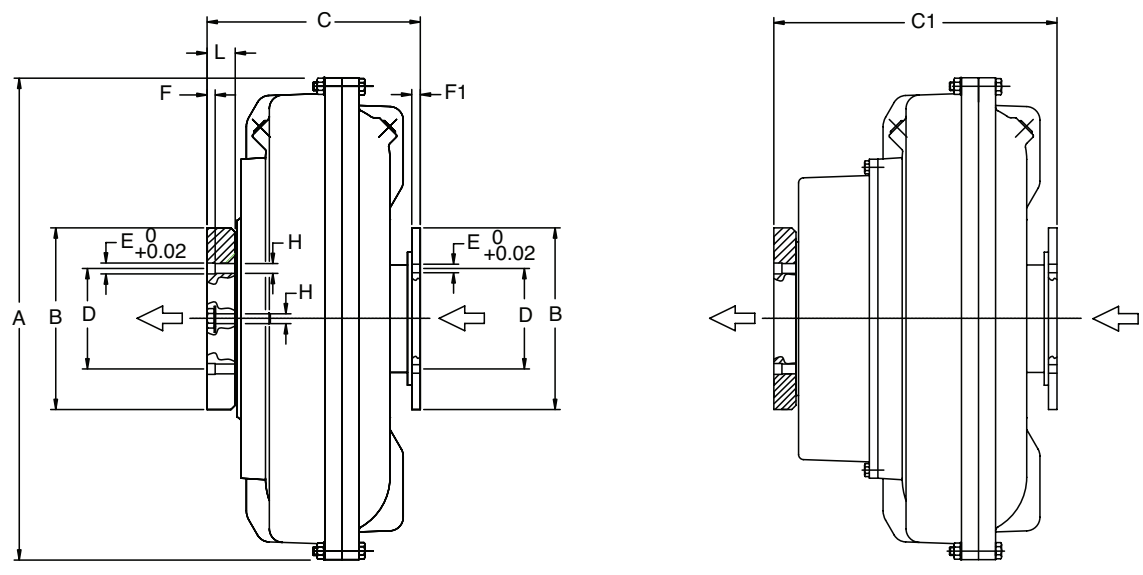

KCM

CKCM

Dimensional Data Sheet - KCM & CKCM

Size	A	B	C		D	E		H	Gear Coupling Size	Weight (lb) Less Oil		Oil U.S. Gal. max.	
			KCM	CKCM		#	DIA			KCM	CKCM	KCM	CKCM
7	8.98	4.57	5.51	-	3.75	6	0.25	1/4-28 UNF	1	16	-	0.24	-
8	10.08	4.57	5.71	-	3.75	6	0.25	1/4-28 UNF	1	18	-	0.34	-
9	11.61	6.00	7.44	-	4.81	8	0.38	3/8-24 UNF	1.5	31	-	0.52	-
11	12.80	6.00	7.80	9.61	4.81	8	0.38	3/8-24 UNF	1.5	35	-	0.73	-
12	14.65	6.00	7.80	10.43	4.81	8	0.38	3/8-24 UNF	1.5	46	53	1.08	1.27
13	15.67	6.00	8.80	11.14	4.81	8	0.38	3/8-24 UNF	1.5	62	68	1.37	1.53
15	18.11	8.39	9.88	12.56	7.13	6	0.62	5/8-11 UNC	2.5	104	112	2.02	2.27
17	20.47	8.39	10.83	13.98	7.13	6	0.62	5/8-11 UNC	2.5	146	159	3.09	3.59
19	22.24	8.39	10.83	13.98	7.13	6	0.62	5/8-11 UNC	2.5	165	178	3.75	4.36
21	24.41	9.45	12.44	16.38	8.13	8	0.62	5/8-11 UNC	2.3	240	262	5.02	6.08
24	28.11	9.45	12.44	16.38	8.13	8	0.62	5/8-11 UNC	2.3	285	306	7.50	8.24
27	30.71	11.02	16.06	20.71	9.50	8	0.75	3/4-10 UNC	3.5	454	505	11.09	13.21
29	33.86	11.02	17.2	21.85	9.50	8	0.75	3/4-10 UNC	3.5	562	613	14.53	16.65
34	39.37	12.52	19.8	24.96	11.00	8	0.75	3/4-10 UNC	4	960	978	21.80	24.44
46	52.36	18.0	-	-	15.75	14	0.88	7/8-11 UNC	6	-	-	-	-



SELECTION/DIMENSIONS

Fluid Coupling PART NUMBERS

Fluid Couplings

Part #	Part Description
118625	7 KCM - LESS 1.0SB GEAR COUPLING
118626	8 KCM - LESS 1.0SB GEAR COUPLING
118627	9 KCM - LESS 1.5SB GEAR COUPLING
118628	11 KCM - LESS 1.5SB GEAR COUPLING
118629	12 KCM - LESS 1.5SB GEAR COUPLING
118630	13 KCM - LESS 1.5SB GEAR COUPLING
118631	15 KCM - LESS 2.5SB GEAR COUPLING
118632	17 KCM - LESS 2.5SB GEAR COUPLING
118633	19 KCM - LESS 2.5SB GEAR COUPLING
118634	21 KCM - LESS 2.5SB GEAR COUPLING
118635	24 KCM - LESS 2.5SB GEAR COUPLING
118636	27 KCM - LESS 3.5EB GEAR COUPLING
118637	29 KCM - LESS 3.5EB GEAR COUPLING

Delay Fill Fluid Couplings

Part #	Part Description
118638	11 CKCM - LESS 1.5SB GEAR COUPLING
118639	12 CKCM - LESS 1.5SB GEAR COUPLING
118640	13 CKCM - LESS 1.5SB GEAR COUPLING
118641	15 CKCM - LESS 2.5SB GEAR COUPLING
118642	17 CKCM - LESS 2.5SB GEAR COUPLING
118643	19 CKCM - LESS 2.5SB GEAR COUPLING
118644	21 CKCM - LESS 2.5SB GEAR COUPLING
118645	24 CKCM - LESS 2.5SB GEAR COUPLING
118646	27 CKCM - LESS 3.5EB GEAR COUPLING
118647	29 CKCM - LESS 3.5EB GEAR COUPLING

* Gear Coupling Kit ordered separately (See below)

Gear Couplings for KCM Fluid Coupling

Fluid Coupling Size 7 - 8	
Part Numbers	Description
013110	DGF 1.0 FLEX HUB
012975	DGF 1.0 SLEEVE SB
012987	KCM/CKCM 7 - 8 HARDWARE KIT
Fluid Coupling Size 9 - 13	
Part Numbers	Description
013114	DGF 1.5 FLEX HUB
012976	DGF 1.5 SLEEVE SB
012988	KCM/CKCM 9 - 13 HARDWARE KIT
Fluid Coupling Size 15 - 24	
Part Numbers	Description
013122	DGF 2.5 FLEX HUB
012978	DGF 2.5 SLEEVE SB
012989	KCM/CKCM 15 - 24 HARDWARE KIT
Fluid Coupling Size 27 - 34	
Part Numbers	Description
013130	DGF 3.5 FLEX HUB
013131	DGF 3.5 SLEEVE EB
012990	KCM/CKCM 27 - 29 HARDWARE KIT

Gear couplings are required for shaft attachment. For a complete gear coupling attachment kit, please order - (2) flex hubs (reborable), (2) sleeves (includes seal), and (1) hardware kit.

Size	Outside	Flange	Flange	Hub	Undercut	Undercut	Hole	Bolt	Number of Bolts	Max Bore
	Diameter	Width	Thickness	Diameter	Depth	Diameter	Diameter	Circle		
	A	J	T	F	I	H	U	B.C.		
All Dimensions in Inches										
1 SB	4-9/16	1-21/32	9/16	3	3/32	2 -7/8	1/4	3-3/4	6	1.625"
1.5 SB	6	1-7/8	3/4	3-7/8	3/32	3-11/16	3/8	4-13/16	8	2.375"
2.5 SB	8-3/8	2-7/8	15/16	5-13/16	3/32	5-7/16	1/2	7	10	3.750"
3.5 EB	11	3-13/16	1-1/8	7-27/32	3/32	7-3/8	3/4	9-1/2	8	4.750"

FEATURES/BENEFITS PAGE PT4-2	NOMENCLATURE PAGE PT4-3	SELECTION PAGE PT4-3	SELECTION/DIMENSIONS PAGE PT4-5
---------------------------------	----------------------------	-------------------------	------------------------------------



SELECTION/DIMENSIONS

Fluid Coupling

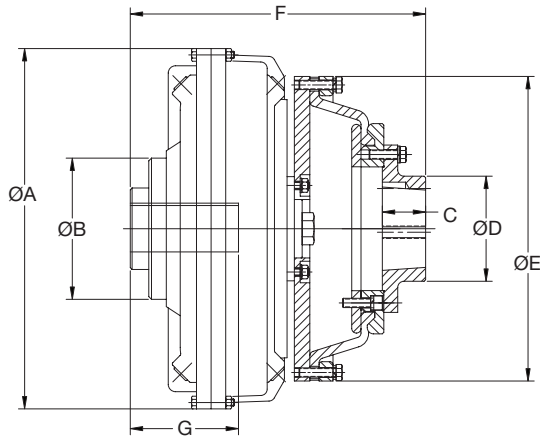

KCP-CONSTANT FILL

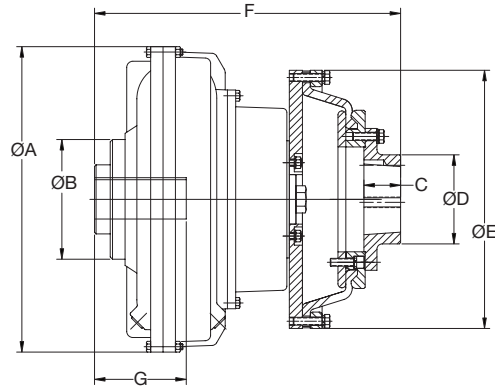

CKCP-DELAY FILL

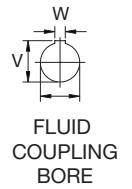

FLUID COUPLING BORE

Dimensional Data Sheet - KCP & CKCP

Size	Fluid Coupling Bore	A	B	C	D	E	F		G	V		W	PH Element	PH Max Bore	TL Bushing	Max Torque (in-lb)	Max RPM
							KCP	CKCP		+0.010 / -0.000							
11	1.625	12.80	5.04	1.75	4.25	10.31	11.76		3.75	1.796	0.375	PH96	2 11/16	2517	2300	3300	
	1.875								4.38	1.972	0.5						
12	1.625	14.57	5.71	1.75	4.25	12.31	11.71	14.37	3.75	1.796	0.375	PH116	2 11/16	2517	3150	3200	
	1.875								4.38	1.972	0.5						
13	1.875	15.67	7.06	1.75	4.25	13.81	13.58	15.94	4.38	2.093	0.5	PH131	2 11/16	2517	4700	3000	
	2.125								5.00	2.350	0.5						
	2.375								5.63	2.480	0.625						
15	2.125	18.11	8.00	3.50	7.69	18.31	18.36	21.04	5.00	2.350	0.5	PH172	3 15/16	3535	6600	2600	
	2.375								5.63	2.651	0.625						
	2.875								7.00	2.992	0.75						
17	2.375	20.47	8.86	3.50	7.69	18.31	19.23	22.38	5.63	2.651	0.625	PH172	3 15/16	3535	9200	2400	
	2.875								7.00	3.205	0.75						
	3.375								7.63	3.635	0.875						
19	2.375	22.24	8.86	3.50	7.69	18.31	19.23	22.38	5.63	2.651	0.625	PH172	3 15/16	3535	12900	2200	
	2.875								7.00	3.205	0.75						
	3.375								7.63	3.635	0.875						
21	2.375	24.41	9.84	4.00	8.63	20.31	22.79	26.73	7.00	3.205	0.75	PH192	4 7/16	4040	17300	2000	
	3.375								8.25	3.635	0.875						
24	2.875	27.95	9.84	4.00	8.63	20.31	22.79	26.73	7.00	3.205	0.75	PH192	4 7/16	4040	24500	1800	
	3.375								8.25	3.760	0.875						
	3.875								8.50	4.106	1						

SELECTION/DIMENSIONS



Fluid Coupling PART NUMBERS

PX STYLE FLUID CPLG - INCLUDES ELEMENT *

Part #	Part Description
000423	11KCP X 1-5/8" FLUID CPLG-2517
000424	11KCP X 1-7/8" FLUID CPLG-2517
000426	12KCP X 1-5/8" FLUID CPLG-2517
000427	12KCP X 1-7/8" FLUID CPLG-2517
000429	13KCP X 1-7/8" FLUID CPLG-2517
000430	13KCP X 2-1/8" FLUID CPLG-2517
000431	13KCP X 2-3/8" FLUID CPLG-2517
000432	15KCP X 2-1/8" FLUID CPLG-3535
000433	15KCP X 2-3/8" FLUID CPLG-3535
000434	15KCP X 2-7/8" FLUID CPLG-3535
000435	17KCP X 2-3/8" FLUID CPLG-3535
000436	17KCP X 2-7/8" FLUID CPLG-3535
000437	17KCP X 3-3/8" FLUID CPLG-3535
000438	19KCP X 2-3/8" FLUID CPLG-3535
000439	19KCP X 2-7/8" FLUID CPLG-3535
000440	19KCP X 3-3/8" FLUID CPLG-3535
000441	21KCP X 2-3/8" FLUID CPLG-4040
000442	21KCP X 3-3/8" FLUID CPLG-4040
000443	24KCP X 2-3/8" FLUID CPLG-4040
000444	24KCP X 3-3/8" FLUID CPLG-4040
000445	24KCP X 3-7/8" FLUID CPLG-4040

Delay Fill

Part #	Part Description
000454	11CKCP X 1-5/8" FLUID CPLG-2517
000455	11CKCP X 1-7/8" FLUID CPLG-2517
000457	12CKCP X 1-5/8" FLUID CPLG-2517
000458	12CKCP X 1-7/8" FLUID CPLG-2517
000460	13CKCP X 1-7/8" FLUID CPLG-2517
000461	13CKCP X 2-1/8" FLUID CPLG-2517
000462	13CKCP X 2-3/8" FLUID CPLG-2517
000463	15CKCP X 2-1/8" FLUID CPLG-3535
000464	15CKCP X 2-3/8" FLUID CPLG-3535
000465	15CKCP X 2-7/8" FLUID CPLG-3535
000466	17CKCP X 2-3/8" FLUID CPLG-3535
000467	17CKCP X 2-7/8" FLUID CPLG-3535
000468	17CKCP X 3-3/8" FLUID CPLG-3535
000469	19CKCP X 2-3/8" FLUID CPLG-3535
000470	19CKCP X 2-7/8" FLUID CPLG-3535
000471	19CKCP X 3-3/8" FLUID CPLG-3535
000472	21CKCP X 2-3/8" FLUID CPLG-4040
000473	21CKCP X 3-3/8" FLUID CPLG-4040
000474	24CKCP X 2-3/8" FLUID CPLG-4040
000475	24CKCP X 3-3/8" FLUID CPLG-4040
000476	24CKCP X 3-7/8" FLUID CPLG-4040

Mounting of KCP and CKCP may require the motor shaft to be tapped.

Part #s include mechanism, element and coupling assembly.

* TAPER-LOCK bushing ordered separately.

FEATURES/BENEFITS PAGE PT4-2	NOMENCLATURE PAGE PT4-3	SELECTION PAGE PT4-3	SELECTION/DIMENSIONS PAGE PT4-5
---------------------------------	----------------------------	-------------------------	------------------------------------



SELECTION/DIMENSIONS

Replacement Fuse Plugs

Fluid Coupling Size (Range)	Part Number	Temperature
6	019161	290°F
6	019162	350°F
7 - 12	019163	290°F
7 - 12	019164	350°F
13 - 24	019165	290°F
13 - 24	019166	350°F
27 - 34	019167	290°F
27 - 34	019168	350°F

PT Component
Reference Guide

Couplings

Clutches and Brakes

FLEXIDYNE

Fluid Couplings

TORQUE-TAMER

Bushings