

CONTENTS



FLEXIDYNE®

Features/Benefits	PT3-2
Specification	PT3-3
How To Order	PT3-3
Nomenclature	PT3-3
Selection	PT3-4
Selection/Dimensions	
FLEXIDYNE Drives	PT3-8
FLEXIDYNE Couplings	PT3-9
PH Couplings	PT3-11
C-FLEX Modules	PT3-13
Modifications/Accessories	PT3-15
Engineering/Technical	PT3-25
Part Number Index	INDEX-1
Keyword Index	INDEX-67

PT Component
Reference Guide

Couplings

Clutches and Brakes

FLEXIDYNE

Fluid Couplings

TORQUE-TAMER

Bushings



FEATURES/BENEFITS

FLEXIDYNE

- **Smoother, Faster Acceleration**

- Smaller motors may be used
- Motor starts under no load conditions
- Smoother starts
- Starting torque can be easily customized

- **More Efficient Design**

- Permits use of standard NEMA Design B motors
- High torque or high slip motors not needed
- Reduced voltage starters not needed
- Wound rotor motors not needed

- **More Efficient Running**

- No slip at running speed means no wear, no heat, no power loss

- **Overload Protection**

- Provides overload protection at overloads somewhat greater than starting torque
- Protection devices to prevent damage to FLEXIDYNE are available

- **Low Current Draw**

- Less than twice the nameplate amperage during both starting and overload periods
- Many electric utilities recommend FLEXIDYNE

- **Increased Productivity**

- Eliminates product spillage and machine damage due to harsh starts or jammed loads



FLEXIDYNE

SPECIFICATION

FLEXIDYNE is available in three designs: Drives, Couplings, and C-Flex Modules to meet most system needs. The Drive style is designed to mount directly on the motor shaft to provide an extremely compact unit for belted service. The Coupling style provides a versatile solution for transmitting torque between in-line shafts. The C-Flex Module style provides all of the benefits of regular FLEXIDYNE in a compact package that readily mounts between C-Face motors and reducers.

HOW TO ORDER

DRIVE STYLE

Specify mechanism size and bore size. Select a sheave from the selection tables found in the Modifications/Accessories section. Refer to the part number when ordering.

COUPLING STYLE

On size 5C - specify bore size. A complete coupling consists of (1) output hub and (1) mechanism.

On larger sizes - specify coupling size, and bore size. A complete coupling consists of (1) mechanism, including flexible disc, (1) Poly-Disc flange, and (2) bushings.

Type PH Couplings - specify coupling size, bore size of the driven end and the motor end. A complete coupling consists of (1) mechanism, (1) Taper-Lock or Bored-To-Size flange assembly, and (1) element.

Refer to the part numbers when ordering.

C-FLEX MODULE STYLE

Specify the C-Flex unit size and the FLEXIDYNE mechanism. Refer to the part numbers when ordering.

FLOW CHARGE

Determine the amount of flow charge to be ordered by referring to the Flow Charge tables in the Modifications/Accessories section. Choose between cast steel and stainless. Refer to the part number when ordering.

NOMENCLATURE

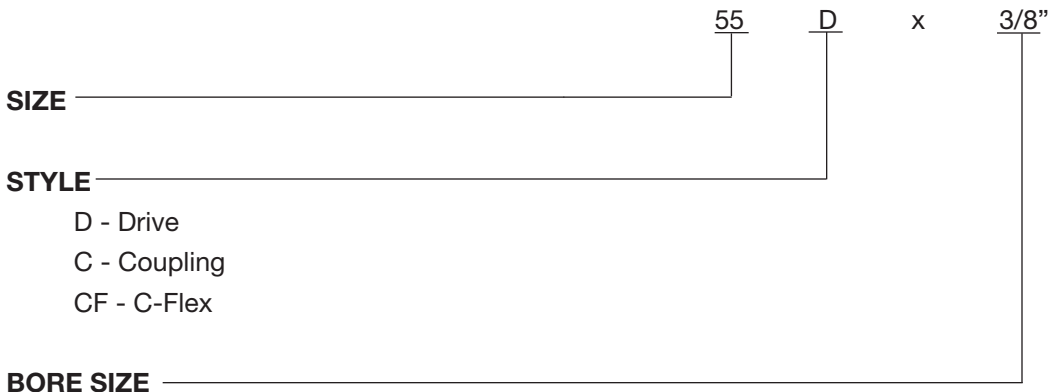



SELECTION

FLEXIDYNE

SIMPLIFIED SELECTION PROCEDURE

The tables on pages PT3-6 -PT3-7 give FLEXIDYNE mechanism size and amount of flow charge to provide starting capacities from 100-200% of motor nameplate HP of a NEMA Design B squirrel cage induction motor. This starting capacity is satisfactory for most ordinary industrial applications.

The FLEXIDYNE unit sizes shown in the simplified selection tables suggest the most economical FLEXIDYNE mechanism for a given RPM and HP. In some cases, under the same conditions, there may be other sizes of FLEXIDYNE which may be utilized.

STEP 1

Determine the approximate starting torque percentage for the application. As a guide, suggested percentages are listed in the table below.

STEP 2

Determine motor speed and HP to be used. Refer to tables on pages PT3-6 -PT3-7 based on 1760, 1175, or 875 RPM NEMA Design B motors.

STEP 3

Check maximum bore from Selection/Dimensions pages.

FLEXIDYNE Mechanism Starting Torque

Application	Range	Application	Range	Application	Range
Air Conditioning	130-175%	Cranes (Bridge Draw)	150-200%	Mixers	130-150%
Agitators	130-175%	Crushers	150-200%	Oven Drivers	150-175%
Belt Conveyors	130-150%	Dryers	130-175%	Paper Mills	
Blenders	130-175%	Fans	150-175%	Agitator	130-175%
Blowers	150-175%	Lumber Chippers	150-200%	Hydropulper	130-175%
Bucket Elevators	130-175%	Sawdust Conv.	130-175%	Chipper	150-200%
Can Filling Machine	125-150%	Matl. Handling Equip.	130-150%	Drier	130-150%
Compressors	150-175%	Mills (Ball, Pebble)	150-175%	Pumps	125-150%

NOTE: Since FLEXIDYNE Drives and Couplings are selected primarily as torque limiting devices by using the starting torque percentages shown above, the use of a service factor is not necessary.



FLEXIDYNE OTHER APPLICATIONS

The information on the previous page provides a simple method of selecting the FLEXIDYNE mechanism size when used with NEMA Design B motors under general operating conditions. Selection for any other application is based on the specific conditions and requirements of the installation. The power transmitting characteristics of the FLEXIDYNE unit vary with input speed and amount of flow charge used. A FLEXIDYNE unit can be adapted to the specific conditions and requirements of the individual application by using the proper amount of flow charge.

FLEXIDYNE units are not recommended for variable speed applications, engines or speeds below 700 RPM.

DODGE engineers welcome inquiries on FLEXIDYNE mechanism selection for applications not previously covered. It is suggested that their experience be called upon to recommend the best installation. To contact Dodge engineering please call 864-284-5700.

Please provide the following information with your request:

- Type, HP, RPM, shaft size of motor
- Type, RPM, shaft size of driven machine
- Frequency of starts, reversals, and overloads
- Time required to accelerate
- For high inertia loads, WR^2
- Starting HP and Overload Breakaway HP desired
- Functions the FLEXIDYNE unit must perform

FEATURES/BENEFITS PAGE PT3-2	SPECIFICATION PAGE PT3-3	SELECTION/DIMENSIONS PAGE PT3-8	ENGINEERING/TECHNICAL PAGE PT3-26
---------------------------------	-----------------------------	------------------------------------	--------------------------------------



SELECTION

FLEXIDYNE

SELECTION OF FLEXIDYNE MECHANISM SIZE (BASED ON % OF STARTING TORQUE FOR NEMA DESIGN B MOTORS)

1760 RPM

Rated Motor HP	FLEXIDYNE Mech Size	100% @ 1760 rpm			125% @ 1750 RPM			150% @ 1740 RPM			175% @ 1700 RPM			200% @ 1650 RPM		
		Start -ing HP	Flow Charge		Start -ing HP	Flow Charge		Start -ing HP	Flow Charge		Start -ing HP	Flow Charge		Start -ing HP	Flow Charge	
			Lbs.	Oz.		Lbs.	Oz.		Lbs.	Oz.		Lbs.	Oz.		Lbs.	Oz.
1/2	5D, 5C	.5	0	8	.62	0	9	.75	0	9.5	.85	0	10	.94	0	10.5
3/4	5D, 5C	.75	0	9	.94	0	10.5	1.1	0	11	1.3	0	11.5	1.4	*	*
1	55D, 55C	1.0	0	9	1.2	0	10	1.5	0	11	1.7	0	12	1.9	0	13
1-1/2	55D, 55C	1.5	0	10	1.9	0	12	2.2	0	13.5	2.5	0	14	2.8	0	16
2	55D, 55C	2.0	0	12	2.5	0	13.5	3.0	0	15	3.4	0	17	3.8	0	18
3	70D, 70C	3.0	1	11	3.7	1	13	4.5	1	14	5.1	2	0	5.7	2	2
5	70D, 70C	5.0	1	14	6.2	2	1	7.5	2	4	8.5	2	8	9.4	2	10
7-1/2	75D, 75	7.5	1	11	9.4	1	14	11.2	2	1	12.7	2	4	14.1	2	9
10	75D, 75C	10	1	15	12.5	2	3	14.9	2	6	17.0	2	9	18.8	2	12
15	9D, 9C	15	2	9	18.8	3	0	22.3	3	7	25.5	3	13	28.3	4	2
20	9D, 9C	20	3	2	25	3	10	30	4	0	34	4	8	38	5	3
25	11D, 11C	25	4	3	31	4	12	37	5	0	42	5	8	47	6	2
30	11D, 11C	30	4	10	37	5	0	45	5	12	51	6	3	57	6	12
40	11D, 11C	40	5	5	50	6	0	60	6	8	68	7	3	75	8	0
50	11D, 11C	50	5	13	62	6	10	74	7	6	85	8	2	94	8	11
60	15D, 15116	60	7	3	75	8	3	89	9	1	102	10	1	113	10	14
75	15D, 15116	75	8	3	94	9	3	111	10	3	127	11	0	141	12	0
100	15D, 15116	100	9	7	125	10	10	149	11	9	170	12	8	188	13	5
125	D15131 ▲	125	7	3	156	8	6	186	9	4	212	10	4	236	11	1
150	D15131 ▲	150	8	3	187	9	3	224	10	3	255	11	1	283	12	1

1175 RPM

Rated Motor HP	FLEXIDYNE Mech Size	100% @ 1175 rpm			125% @ 1160 RPM			150% @ 1150 RPM			175% @ 1130 RPM			200% @ 1100 RPM		
		Start -ing HP	Flow Charge		Start -ing HP	Flow Charge		Start -ing HP	Flow Charge		Start -ing HP	Flow Charge		Start -ing HP	Flow Charge	
			Lbs.	Oz.		Lbs.	Oz.		Lbs.	Oz.		Lbs.	Oz.		Lbs.	Oz.
1/4	5D, 5C	.25	0	8.546	0	10.5
1/2	55D, 55C	.5	0	11	.62	0	15	.75	0	13	.85	0	15	.94	0	16
3/4	55D, 55C	.75	0	12	.94	0	15	1.1	0	16	1.3	0	17	1.4	0	18
1	70D, 70C	1.0	1	10	1.2	1	12	1.5	1	14	1.7	2	1	1.9	2	4
1-1/2	70D, 70C	1.5	1	13	1.9	2	1	2.2	2	3	2.5	2	6	2.8	2	9
2	75D, 75C	2.0	1	10	2.5	1	13	3.0	2	0	3.4	2	2	3.8	2	6
3	75D, 75C	3.0	1	15	3.7	2	3	4.5	2	7	5.1	2	10	5.7	2	12
5	9D, 9C	5.0	2	4	6.2	2	11	7.4	3	1	8.5	3	8	9.4	3	12
7-1/2	9D, 9C	7.5	3	0	9.3	3	9	11.1	3	14	12.7	4	4	14.1	4	12
10	11D, 11C	10	5	0	12.4	5	5	14.8	5	10	17	6	3	19	7	0
15	11D, 11C	15	5	14	18	6	5	22	7	0	25	7	14	28	9	0
20	11D, 11C	20	6	8	25	7	14	30	8	4	34	8	13	38	9	10
25	15D, 15116	25	8	8	31	9	13	37	10	12	42	11	13	47	12	10
30	15D, 15116	30	9	7	37	10	10	44	11	11	51	12	9	57	13	8
40	15D, 15116	40	10	14	50	12	14	59	13	0	68	14	0	75	15	3
50	15D	50	12	0	62	13	1	74	14	2	85	15	8
	D15116 ▲	50	8	8	62	9	13	74	10	12	85	11	8	94	12	0
	18D	94	15	11
60	15D	60	12	11	75	14	1	89	15	6
	D15116 ▲	60	9	7	75	10	10	89	11	11	102	12	9	113	13	8
	18D	102	17	4	113	19	6
75	15D	75	13	14	93	15	8
	D15116 ▲	75	10	9	93	11	13	111	12	11	127	13	10	141	14	12
	18D	111	17	10	127	19	10	141	21	14
100	18D, 18172	100	15	12	124	18	7	148	20	9	170	22	13	189	24	13
125	18D, 18172	125	18	7	155	21	1	185	23	3	212	25	3	236	27	3
150	18D, 18172	150	20	5	186	22	15	222	25	0	254	27	0	283	29	4
200	D18172 ▲	200	15	12	249	18	10	285	20	5	340	22	13	377	24	13
250	D18172 ▲	250	18	9	312	21	0	370	23	2	424	25	3	470	27	0

* Use a Size 55 FLEXIDYNE unit. Fill with 11 oz. of Flow Charge for 1.5 Starting HP

▲ Flow charge is listed for one cavity. For duplex (double cavity) units, numbered with prefix "D", the amount listed is would have to be doubled.

FEATURES/BENEFITS PAGE PT3-2	SPECIFICATION PAGE PT3-3	SELECTION/DIMENSIONS PAGE PT3-8	ENGINEERING/TECHNICAL PAGE PT3-26
---------------------------------	-----------------------------	------------------------------------	--------------------------------------

SELECTION



FLEXIDYNE

SELECTION OF FLEXIDYNE MECHANISM SIZE (BASED ON % OF STARTING TORQUE FOR NEMA DESIGN B MOTORS)

875 RPM

Rated Motor HP	FLEXIDYNE Mech Size	100% @ 875 rpm			125% @ 870 RPM			150% @ 850 RPM			175% @ 840 RPM			200% @ 820 RPM		
		Start-ing HP	Flow Charge		Start-ing HP	Flow Charge		Start-ing HP	Flow Charge		Start-ing HP	Flow Charge		Start-ing HP	Flow Charge	
			Lbs.	Oz.		Lbs.	Oz.		Lbs.	Oz.		Lbs.	Oz.		Lbs.	Oz.
1/2	70D, 70C	.5	1	12	.62	1	15	.75	2	1	.85	2	4	.94	2	6
3/4	70D, 70C	.75	2	0	.94	2	3	1.1	2	6	1.3	2	8	1.4	2	12
1	75D, 75C	1.0	1	13	1.2	2	0	1.5	2	3	1.7	2	7	1.9	2	8
1-1/2	75D, 75C	1.5	2	2	1.9	2	7	2.2	2	10	2.5	2	11	2.8	2	12
2	9D, 9C	2.0	2	6	2.5	2	12	2.9	3	0	3.4	3	8	3.7	3	12
3	9D, 9C	3.0	3	0	3.7	3	8	4.4	4	0	5.0	4	6	5.6	4	14
5	11D, 11C	5.0	5	6	6.2	5	14	7.3	6	10	8.4	7	0	9.4	7	8
7-1/2	11D, 11C	7.5	6	8	9.3	7	2	10.9	8	0	12.6	8	8	14.0	9	5
10	15D, 15116	10	8	6	12.4	9	8	14.6	10	9	16.8	11	7	18.7	12	5
15	15D, 15116	15	10	5	19	11	7	22	12	8	25	13	5	28	14	6
20	15D, 15116	20	11	12	25	12	13	29	13	14	34	15	1	38	15	8
25	D15116	25	9	7	31	10	9	36	11	11	42	12	8	47	13	5
30	D15116	30	10	5	37	11	7	44	12	8	50	13	5	56	14	6
40	18D, 18172	40	15	3	50	18	0	58	20	6	67	22	8	75	24	7
50	18D, 18172	50	17	14	62	20	4	73	22	14	84	24	14	94	26	14
60	18D, 18172	60	19	13	75	22	6	87	24	15	101	26	1	112	28	12
75	D18172 ▲	75	14	8	93	17	2	109	19	11	126	21	13	141	23	12
100	D18172 ▲	100	17	14	124	20	4	146	22	14	168	24	14	187	26	14
125	D18172 ▲	125	20	2	155	22	13	182	25	7	210	27	4	234	29	4

▲ Flow charge is listed for one cavity. For duplex (double cavity) units, numbered with prefix "D", the amount listed would have to be doubled.

FEATURES/BENEFITS PAGE PT3-2	SPECIFICATION PAGE PT3-3	SELECTION/DIMENSIONS PAGE PT3-8	ENGINEERING/TECHNICAL PAGE PT3-26
---------------------------------	-----------------------------	------------------------------------	--------------------------------------



SELECTION/DIMENSIONS

FLEXIDYNE Drives

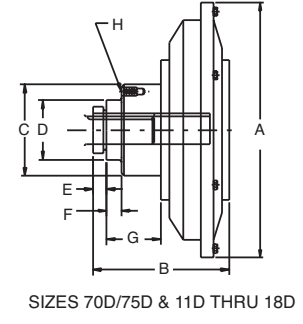
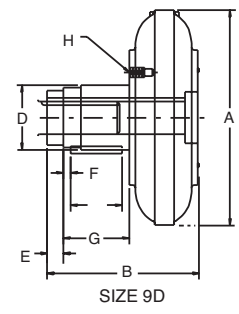
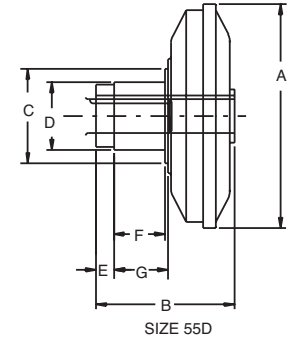
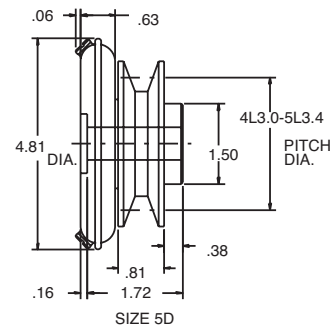

Each FLEXIDYNE, including a container of flow charge, is individually packaged. Cutout features and a cross section drawing are shown in the Modifications/ Accessories section.



NOTE: Drawings are for dimensional purpose only and do not necessarily represent construction

5D FLEXIDYNE Drive

Nom. Stock Bores ▲	w/Integral Sheave P.D.	Part Number	Wt. Lbs.	Keyseat	Key Req'd.
5/8	4L2.2-5L2.6	305106	3.4	3/16 X 3/32 X 1-11/16	3/16 X 3/16 X 1-3/8
	4L3.0-5L3.4	305101	2.4		
	4L3.6-5L4.0	305102	3.6		
3/4 (Max.)	4L3.0-5L3.4	305103	2.7	3/16 X 3/32 X 1-11/16	3/16 X 3/16 X 1-7/8

▲ +.0005" +.0025" over nominal. Bores not listed will be quoted on application.

FEATURES/BENEFITS PAGE PT3-2	SPECIFICATION PAGE PT3-3	SELECTION PAGE PT3-4	ENGINEERING/TECHNICAL PAGE PT3-26
---------------------------------	-----------------------------	-------------------------	--------------------------------------

SELECTION/DIMENSIONS



FLEXIDYNE

55D Thru 18D FLEXIDYNE Drive

DRIVE SIZE	MAX. RPM	NOM STOCK BORES *	Part Number	Wt Lbs	Keyseat ▼	Key Req'd
55D	3600	5/8	305015	3.0	3/16 x 3/32 x 3-1/16	3/16 x 3/16 x 1-3/8
		7/8 (Max)	305016	2.8		
70D	3300	7/8	305021	9.5	3/16 x 3/32 x 3-5/16	3/16 x 3/16 x 1-3/8
		1-1/8 (Max.)	305022	9.7	1/4 x 1/8 x 3-5/16	1/4 x 1/4 x 1-3/4
75D	3300	1	305085	10.0	1/4 x 1/8 x 4	1/4 x 1/4 x 1-3/4
		1-3/8 (Max.)	305057		10.2	5/16 x 3/32 x 4
9D	2300	1-1/8	309070	23.0	1/4 x 1/8 x 6	1/4 x 1/4 x 2
		1-1/4	309071	24.0	1/4 x 1/8 x 6	1/4 x 1/4 x 2-3/4
		1-3/8	309072	23.5	5/16 x 5/32 x 6	5/16 x 5/16 x 2-3/4
		1-5/8 (Max.)	309073	23.0	3/8 x 1/8 x 6	3/8 x 5/16 x 3-3/4
11D	2400	1-3/8	311070	45.0	5/16 x 5/32 x 7-5/16	5/16 x 5/16 x 2-3/4
		1-5/8	311071	46.0	3/8 x 3/16 x 7-5/16	3/8 x 3/8 x 3-3/4
		1-7/8 (Max.)	311072	45.0	1/2 x 1/8 x 7-5/16	1/2 x 3/8 x 5-1/2 ◆
11DL	2400	2-1/8 (Max.)	311073	44.0	1/2 x 1/8 x 7-5/16	1/2 x 3/8 x 5-1/2 ◆
15D	1800	1-7/8	315070	100.0	1/2 x 1/4 x 10-3/16	1/2 x 1/2 x 5
		2-1/8	315071	92.0	1/2 x 1/4 x 10-3/16	1/2 x 1/2 x 5
		2-3/8 (Max.)	315072	96.0	5/8 x 1/8 x 10-3/16	5/8 x 7/16 x 5-1/2 ◆
18D	1500	2-7/8	318060	154.0	3/4 x 3/8 x 10-3/16	3/4 x 3/4 x 9-3/4
		3-3/8 (Max.)	318065	154.0	7/8 x 1/4 x 10-3/16	7/8 x 11/16 x 9-3/4 ◆

Size	A	B	C -.000 +.002	D	E	F	G * *	H	
								No. of Holes	Thd's
55D	5.38	3.07	2.752	1.69	0.47	1.38	1.41
70D	8.13	3.56	3.755/3.753	2.81	0.63	0.63	1.03	4	††
75D	8.13	4.25	3.755/3.753	2.81	0.63	0.63	1.72	4	††
9D	9.50	6.75	3.00{	0.69	0.56	3.38	4	♣
11D	11.25	8.28	5.082/5.080	3.610/3.605	0.75	2.50	4.38	4	§
11DL									
15D	14.50	11.19	6.625/6.623	4.63	1.00	3.25	6.31	6	▲
18D	18.00	14.75	9.189/9.187	6.00	1.13	1.50	9.25	6	♣

Note: To facilitate order processing specify part numbers

Setscrews: One furnished over keyway, one @ 120°

* **All sizes:** +.0005" +.0025" over nominal. Bores not listed will be quoted on application

† Key provided

* * Provide 3/32 min. clearance between sheave and FLEXIDYNE drive

◆ Key is furnished for these sizes only

♥ Keyseat begins at left end of FLEXIDYNE drive as viewed in drawings on page PT3-8

♣ 1/4-20x1/2" deep on 3-1/2" Dia. B.C. (1/4x2-1/2" Soc. Hd. Cap Screws w/1-3/8" thd., not furnished).

§ 3/8-16x1-1/8" deep on 4-3/8" Dia. B.C. (3/8x1-3/4" Soc. Hd. Cap Screws w/1-1/4" thd., furnished).

▲ 1/2-13x1-1/4" deep on 5-3/4" Dia. B.C. (1/2x2" Soc. Hd. Cap Screws w/1-1/2" thd., furnished).

♣ 1/2-13x1-5/16" deep on 8-3/16 Dia. B.C. (1/2x2-1/4" Soc. Hd. Cap Screws w/1-1/2" thd., furnished)."

†† 1/4-20x5/8" deep on 3-1/4" Dia. B.C. (1/4x1-1/4" for 70 & 1/4x1-1/4" for 75 furnished).

FEATURES/BENEFITS PAGE PT3-2	SPECIFICATION PAGE PT3-3	SELECTION PAGE PT3-4	ENGINEERING/TECHNICAL PAGE PT3-26
---------------------------------	-----------------------------	-------------------------	--------------------------------------



SELECTION/DIMENSIONS

FLEXIDYNE

5C FLEXIDYNE COUPLING

The 5C FLEXIDYNE Coupling uses a formed steel housing and tubular flexible element. See ordering instructions in table below.

5C FLEXIDYNE Couplings

Available Bores	Keyway	Part Numbers	
		MECHANISM for Motor Shaft (Avg. Wt. 2.2 Lbs.)	OUTPUT HUB for Driven Shaft (Avg. Wt. .55 Lbs.)
1/2"	1/8 x 1/16	305120
5/8"	3/16 x 3/32	305115	305121
3/4"	3/16 x 3/32	305118	305122
7/8"	3/16 x 3/32	305037	305123

Note: Total coupling consists of (1) output hub and (1) mechanism. Order by description x bore. To facilitate order processing, order these items by part number. Max bore of mechanism = 3/4"; output hub = 1".

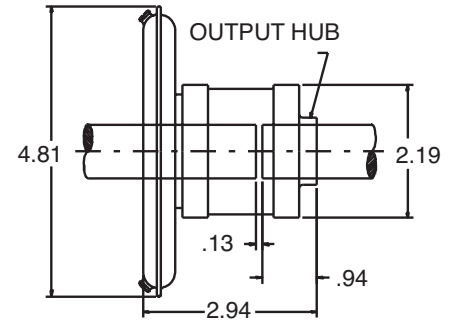
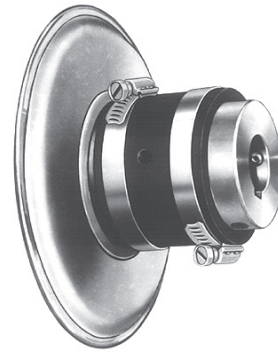

55C thru 11C FLEXIDYNE Couplings

The 55C thru 11C size FLEXIDYNE Coupling uses the same flexible disc used in DODGE POLY-DISC Couplings. The molded polyurethane disc offers longer life and smoother, quieter operation. Disc has excellent physical properties yet remains pliable to cushion shock loads and accommodate misalignment.

H and F Flanges, carried in stock, can be arranged in the position which best suits the application. In H type the bushing installs from the Hub side of the flange; in F type from the Face side. Sufficient flow charge is furnished with each unit.

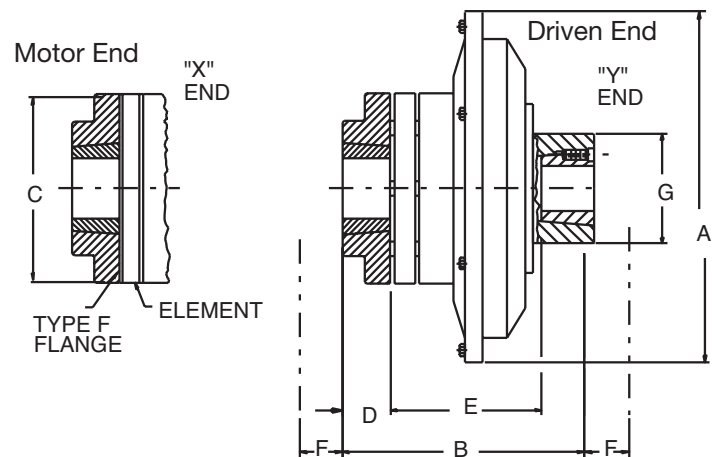



SELECTION/DIMENSIONS

FLEXIDYNE

55C Thru 11C FLEXIDYNE Couplings

Cplg. Size	Bore Range of Bushing		Max. RPM	Cplg. Less Bushings	Items required for Complete Coupling †									
					Mechanism (Includes disc)			Poly-Disc Flange w/o Bush.			Bushings			
	Min.	Max.		Wt. Lbs.	Part No.	Wt. Lbs.	Size	TYPE H		Wt. Lbs.	Motor End		Driven End	
								Part No.	Part No.		Bush No.	Avg. Wt. Lbs.	Bush No.	Avg. Wt. Lbs.
55C	1/2	1	1800	5.0	305019	4.0	2-5/8	008057	008058	1.0	1008	.2	1008	.2
70C	*	*	1800	15.6	305025	13.6	4	008041	008040	2.0	1215	.7	1610	.7
75C	1/2	1-11/16	1800	18.6	305058	14.1	5-1/4	008043	008042	4.5	1615	1.0	1610	.7
9C	1/2	2-11/16	1800	40.6	309074	30.6	7	008045	008044	10.0	2517	2.8	2517	2.8
11C	1/2	2-11/16	1800	57.2	311074	44.2	8	008047	008046	13.0	2517	2.8	2517	2.8

Complete coupling consists of (1) Mechanism, including flexible disc, (1) POLY-DISC Flange, and two bushings.

TAPER-LOCK bushings sold separately.

† To facilitate order processing specify part numbers.

Determine whether H or F Flange is required and order accordingly.

* Motor End: 1/2" - 1-1/4" (Min./Max.); Driven End: 1/2" - 1-5/8"

◆ Normal dimension. Shaft end float which increases or decreases "E" by slight amounts is permissible.

★ 1" on driven end, 1-1/2" on motor end.

▲ Space required to loosen bushing with shortened hex key using screws as jack screws-no puller required.

Keyways-See tables below for standard keyways and shallow keyways.

Standard Keyways

Bore Range	Keyway
1/2 - 9/16 Incl.	1/8 x 1/16
over 9/16 - 7/8 Incl.	3/16 x 3/32
over 7/8 - 1-1/4 Incl.	1/4 x 1/8
over 1-1/4 - 1-3/8 Incl.	5/16 x 5/32
over 1-3/8 - 1-3/4 Incl.	3/8 x 3/16
over 1-3/4 - 2-1/4 Incl.	1/2 x 1/4
over 2-1/4 - 2-3/4 Incl.	5/8 x 5/16
over 2-3/4 - 3-1/4 Incl.	3/4 x 3/8
over 3-1/4 - 3-3/4 Incl.	7/8 x 7/16
over 3-3/4 - 4-1/2 Incl.	1 x 1/2
over 4-1/2 - 5-1/2 Incl.	1-1/4 x 5/8
over 5-1/2 - 6-1/2 Incl.	1-1/2 x 3/4

Shallow Keyways

Bush No.	Bore Range	
1008	15/16 - 1	Note: Key furnished for these exceptions only.
1610	1-9/16 - 11-1/16	
1615		
2517	2-5/16 - 2-11/16	Note: Key furnished for these exceptions only.



SELECTION/DIMENSIONS

FLEXIDYNE

TYPE PH FLEXIDYNE COUPLINGS



This unique combination of PARA-FLEX coupling and FLEXIDYNE mechanism offers maximum protection for motors and driven machines. The FLEXIDYNE unit allows the motor to accelerate quickly and start the load smoothly while the Para-Flex coupling permits up to 1° angular misalignment, up to 1/16" parallel misalignment and 3/32" end float. Consequently, starting torque can be tailored to the driven load requirements while torsional and lateral vibration and shock loads are being absorbed or cushioned.

The driven end of the couplings uses TAPER-LOCK bushings only. However, the motor end is available as bushed or bored-to-size. Bored-to-size flanges accommodate larger shafts than possible with bushed flanges. Smaller size flanges are reversible offering the H and F position from the same flange. A choice of H or F flanges is offered for size PX140.

TAPER-LOCK Bushings

Cplg. Size	For Mechanism		For Flange Assy.	
	No	Avg. Wt Lbs.	No.	Avg. Wt. Lbs.
987	2517	2.8	1610	0.7
1196	2517	2.8	2012	1.4
15116	3030	7.4	2517	2.8
D15116	3030	7.4	2517	2.8
D15131	3030	7.4	2517	2.8
18172	3535	11.5	3535	11.5
D18172	3535	11.5	3535	11.5

Note: For Keyway information, see footnote next page

Type PH FLEXIDYNE Couplings W/ TAPER-LOCK Flanges

Cplg. Size	Cplg. Less Bushings ♦	Items Req'd. for Complete Coupling ▲													
		Mechanism				TAPER-LOCK FLG. ASSY							ELEMENT		
		Driven End Bore Range		Part No.	Wt. Lbs.	Motor End Bore Range		Size	Part Nos. for Respective Types			Wt. Lbs.	Size	Part No.	Wt. lbs.
		Min.	Max.			Min.	Max.		St'd. (Revers-ible)	Type H	Type F				
987	46.7	1/2	2-11/16	309077†	40	1/2	1-11/16	PX70	010603	5.1	PH87	011227	1.6
1196	65.5	1/2	2-11/16	311077	56	1/2	2-1/8	PX80	010604	7.4	PH96	011228	2.1
15116	137.5	1-5/16	3-1/4	315073	120	1/2	2-11/16	PX100	010606	15.0	PH116	011230	2.5
D15116	184.5	1-5/16	3-1/4	315074	167	1/2	2-11/16	PX100	010606	15.0	PH116	011230	2.5
D15131	175.7	1-5/16	3-1/4	315075	150	1/2	2-11/16	PX110	010607	21.6	PH131	011231	4.1
18172	314.2	1-3/16	3-15/16	318110	242	1-3/16	3-15/16	PX140	011134	011154	64.0	PH172	011234	8.2
D18172	320.2	1-3/16	3-15/16	318400	248	1-3/16	3-15/16	PX140	011134	011154	64.0	PH172	011234	8.2

♦ When ordering bushings, specify bore and part number.

† Assembled-to-order. Consult DODGE for delivery.

▲ To facilitate order processing specify part numbers. In sizes 18172 and D18172, determine whether H or F Flange is required and order accordingly. Complete Coupling consists of (1) Mechanism, (1) Taper-LOCK Flange Assembly, (1) Element and (2) Bushings.

Cplg. Size	Coupling Less Bushings ♦		BBS FLANGE ASSEMBLY						
	Rgh. Bored Wt. Lbs.	Fin. Bored Wt. Lbs.	Size	Rough Stock Bore			Fin. Bored w St'd. K. W.		
				Min. Bore ★	Part Number	Wt. Lbs.	Motor End Bore Range ♣	Wt. Lbs. ♦	Set Screw
987	49.5	47.3	PX70BBS		010301	7.9	1/2 - 2-1/8	5.7	
1196	69.1	66.3	PX80BBS		010302	11	1/2 - 2-9/16	8.2	
15116	147.5	139.5	PX100BBS	0	010304	25	1/2 - 3-1/4	17	⊕
D15116	194.5	186.5	PX100BBS		010304	25	1/2 - 3-1/4	17	
D15131	189.1	176.1	PX110BBS		010305	35	1/2 - 3-15/16	22	
18172	336.2	311.2	PX140BBS	2-1/4	010530	86	2-3/4 - 4-1/2	61	♣
D18172	342.2	317.2	PX140BBS	2-1/4	010530	86	2-3/4 - 4-1/2	61	

Note: Complete Coupling consists of (1) Mechanism, (1) BBS Flange Assembly, (1) Element and (1) Bushing.

♥ Bored per order-Sizes PX70 thru PX110 are furnished with a clearance fit from nominal bores (up to 2" +.000-.000. over 2" +.0015 -.0000). In PX140 size, tolerance will be applied to custom bores (up to 3" +.000 -.001. over 3" thru 6" +.0000 -.0015; over 6" +.000 -.002). Largest Bore listed should be considered as maximum.

⊕ One furnished over keyway.

♣ Not furnished unless specified on order.

* Standard keyway is the same as shown on page. For shallow keyway exceptions, see table at right:

NOTE: Taper-LOCK bushings sold separately

♦ Approximate weight with maximum bore

★ -.010 to -.015" no keyway

BS Flg. Size	Bore Range	Keyway	NOTE-Key furnished for these exceptions only
PX70	2 - 2-1/8	1/2 x 1/8	
PX80	2-3/8 - 2-9/16	5/8 x 3/16	
PX100	3-1/16 - 3-1/4	3/4 x 3/16	
PX110	3-11/16 - 3-3/4	7/8 x 1/4	
	3-13/16 - 3-15/16	1 x 1/4	

FEATURES/BENEFITS PAGE PT3-2	SPECIFICATION PAGE PT3-3	SELECTION PAGE PT3-4	ENGINEERING/TECHNICAL PAGE PT3-26
---------------------------------	-----------------------------	-------------------------	--------------------------------------



SELECTION/DIMENSIONS

FLEXIDYNE TYPE PH FLEXIDYNE COUPLINGS (cont.)

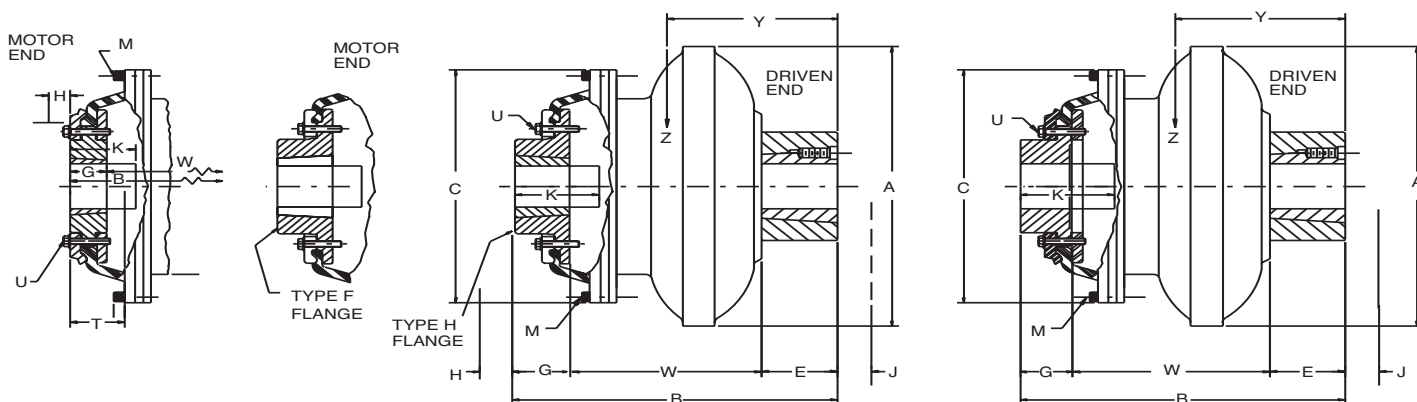

Coupling Size	Max. RPM	A	B		C	E ♣	G		H †	J †	K ▲		M ◆ (No.) & Size of Screws
			TAPER-LOCK Flange	Bored-to-Size Flange			TAPER-LOCK Flange	Bored-to-Size Flange			TAPER-LOCK Flange	Bored-to-Size Flange	
987	1800	9.5	8.75	9.75	9.44	1.75	1	1.75	1.06	1.63	3.19	4.19	(8) 5/16-18 x 1-1/4
1196	1800	11.25	10.06	11.19	10.31	1.75	1.25	2	1.38	1.38	4.38	5.5	(6) 3/8-16 x 1-1/2
15116	1800	14.5	12.31	13.81	12.31	3	1.75	2.63	1.63	2.06	4.44	5.94	(8) 3/8-16 x 1-1/2
D15116	1800	14.5	13.88	15.31	12.31	3	1.75	2.63	1.63	2.06	4.44	5.94	(8) 3/8-16 x 1-1/2
D15131	1800	14.5	14.63	16.38	13.81	3	1.75	3	1.63	2.06	5.19	6.94	(8) 3/8-16 x 2
18172	1500	18	16.31	17.44	18.31	3.5	3.5	3.88	2.63	2.63	7.5	8.5	(8) 1/2-13 x 2
D18172	1500	18	17.81	18.94	18.31	3.5	3.5	3.88	2.63	2.63	7.31	8.5	(8) 1/2-13 x 2

Coupling Size	T		U **		W ■		X	Y ▼	Z ♣ (Lbs.)
	TAPER-LOCK Flange	Bored-to-Size Flange	No. and Size of Screws		TAPER-LOCK Flange	Bored-to-Size Flange			
			TAPER-LOCK Flange	Bored-to-Size Flange					
987	1.59	1.59	(5) 5/16-18 x 1-1/2		5.94	6.25	..	3.88	43
1196	1.91	1.91	(6) 5/16-18 x 1-1/2		7.06	7.44	..	4.13	66
15116	2.09	2.09	(6) 3/8-16 x 1-3/4		7.56	8.19	..	5.5	107
D15116	2.09	2.09	(6) 3/8-16 x 1-3/4		9.13	9.69	..	6.5	153
D15131	2.56	2.56	(6) 3/8-16 x 2		9.88	1.38	..	6.5	153
18172	3.63	3	(8) 1/2-13 x 2-1/2		9.31	10.06	0.19	6.75	209
D18172	3.63	3	(8) 1/2-13 x 2-1/2		10.81	11.56	0.19	6.69	284

♣ Driven shaft should not extend into coupling beyond dimension E.

† Space required to loosen bushing with shortened hex key using screws as jackscrew no puller required

▲ Motor shaft may extend into coupling beyond dimension G but not beyond dimension K.

* Reversible flanges permit Type H or F from the same flange.

■ Normal distance between shafts. End float which increases or decreases W by slight amounts is permissible.

▼ Distance from driven end to center of gravity of driven section of coupling.

♣ Weight of driven section with maximum bore and flow charge.

◆ Socket head cap screw.

** Hex head cap screw, SAE Grade 8; Optional: Nickel plated Grade 8 screws"

Keyways-Standard Keyways are shown on page PT3-11. For Shallow keyway exceptions see table below.

Bush No	Bore Range	NOTE - Key furnished for these exceptions only. See TAPER-LOCK section for Keyway information
1610	1-9/16 - 1-5/8	
2012	1-15/16 - 2-1/8	
2517	2-5/16 - 2-11/16	
3030	2-13/16 - 3-1/4	
3535	3-5/16 - 3-15/16	



SELECTION/DIMENSIONS

FLEXIDYNE C-FLEX MODULE

C-Flex is a system for easily adapting stock FLEXIDYNE couplings to conventional AC motor/C-Face reducer drive combinations. The advantages of this low cost arrangement include soft start and intermittent overload protection utilizing popular NEMA-B motors and across-the-line switching. Costly reduced voltage starters or specially wound motors are not required. FLEXIDYNE unit operates bi-directionally

(reversing) and allows starting of heavy inertial loads without oversized motors.

C-Flex fits all standard NEMA C-Face mountings of 56C, 140TC, 180TC and 210TC frame utilized on 1/2 thru 10 HP, 1750 RPM AC motors. The C-Flex output bearing provides support for single-bearing reducer types, but is equally suitable for reducers having two input shaft bearings.

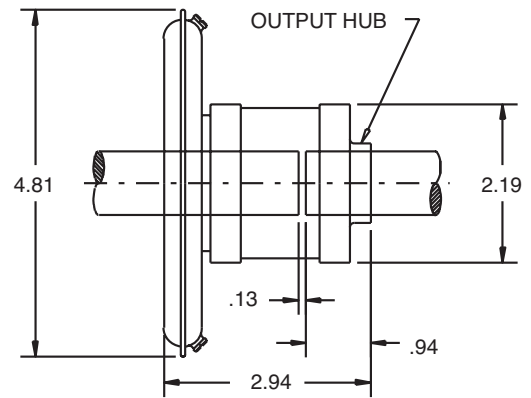
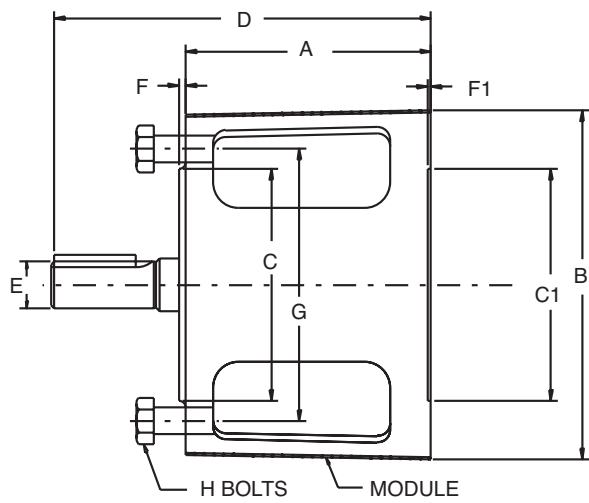

C-Flex Modules

HP Rating @ 1750 RPM	For NEMA C-Face Frame	C-Flex Unit ▲			FLEXIDYNE Mechanism			A	B	C Dia.	C1 Dia.	D	Nom. E. Dia.	F	F1	G Dia. B.C.	H Bolts	
		Model No.	Part No.	Wt. (Lbs.)	Size	Part No.	Wt. (Lbs.)										No.	Size
1/2	56C	150	305026	14.5	5CF x 5/8 ■	305117	2.2	4.75	6.63	4.500	4.501	6.69	5/8	.100	0.19	5.88	4	★
3/4										4.497	4.503			.160				
1	140TC	200	305027	14.5	5CF x 7/8 ■	305037	2	4.75	6.63	4.500	4.501	6.81	7/8	.100	0.19	5.88	4	★
1-1/2										4.497	4.503			.160				
2	180TC	500	305028	54.5	70C	305025	13.6	12.5	10	8.499	8.500	15.31	1-1/8	.200	0.22	7.25	4	*
3										8.497	8.502			.250				
5	210TC	1000	305029	58.2	75C	305058	14.1	12.5	10	8.499	8.500	15.84	1-3/8	.200	0.22	7.25	4	*
7-1/2										8.497	8.502			.250				
10																		

SELECTION DATA-For 1/2 thru 2 HP rating, see table below.
For 3 thru 10 HP rating, see tables on page PT3-6 and PT3-7
■ For 5C FLEXIDYNES see page PT3-10.

▲ Includes all necessary parts except mechanism.
★ 3/8 -16 x 1-1/4 Hex Hd. Cap Screw.
* 1/2 -13 x 1-1/2 Soc. Hd. Cap Screw.

Selection Of 5CF FLEXIDYNE Mechanism Used In C-Flex Module

Rated Motor HP	100% @ 1760 RPM			125% @ 1750 RPM			150% @ 1740 RPM			175% @ 1700 RPM			200% @ 1650 RPM		
	Start ing HP	Flow Charge		Start ing HP	Flow Charge		Start ing HP	Flow Charge		Start ing HP	Flow Charge		Start ing HP	Flow Charge	
		Lbs.	Oz.		Lbs.	Oz.		Lbs.	Oz.		Lbs.	Oz.		Lbs.	Oz.
1/2	.50	0	4	.62	0	5	.75	0	5	.85	0	6	.94	0	7
3/4	.75	0	5	1.00	0	6	1.10	0	6	1.30	0	7	1.40	0	8
1	1.00	0	6	1.20	0	7	1.50	0	7	1.70	0	8	1.90	0	9
1-1/2	1.50	0	7	1.90	0	8	2.20	0	8	2.50	0	9	2.80	0	10
2	2.00	0	8	2.50	0	9	3.00	0	9	3.40	0	10	3.60	0	11



FLEXIDYNE

FLEXIDYNE Flow Charge



Cast steel flow charge is furnished unless otherwise specified. Sufficient amounts for all applications are furnished and included in the price of each FLEXIDYNE unit. The part numbers listed here apply only when extra flow charge is ordered or the application requires stainless steel flow charge.

Flow charge is packaged in a tough transparent plastic bottle which is graduated and has a handy pour spout. This makes handling of flow charge easy whether pouring into the unit or removing flow charge if a change in torque is desired.

Stainless steel flow charge is recommended for applications subject to excessive moisture, humidity or wide temperature variations that may cause internal condensation. It may be ordered to replace that in an existing unit or in place of the cast steel flow charge when ordering a FLEXIDYNE unit.

Sizes 5, 5CF, and 55 FLEXIDYNE mechanisms use SAE S110 (.0234, maximum diameter) steel shot. In sizes 70 and up, SAE S170 (.0331" maximum diameter) steel shot is used.

Flow Charge for Individual FLEXIDYNE Mechanism Applications

FLEXIDYNE Mech. Size ▲	Cast Steel		Stainless Steel	
	Part No.	Wt.	Part No.	Wt.
5, 5CF	311124	1 lb.-2 oz.	311116	11 oz.
55, 6*	311124	1 lb.-2 oz.	311122	1 lb. - 2oz.
7*	311125	3 lb.-5 oz.	311118	1 lb. -14 oz.
8*	311125	3 lb.-5 oz.	311119	3 lb. -5 oz.
70, 75"	311125	3 lb.-5 oz.	311123	2 lb. -13 oz.
9	309111	5 lb.-3 oz.	311120	5 lb. -3 oz.
11	311111	10 lb.	311121	10 lb.
15	315111	20 lb.	(2) 311121	20 lb.
D15, 18	(1) 315111 (1) 311111	30 lb.	(3) 311121	30 lb.
D18	(3) 315111	60 lb.	(2) 311113 (1) 311121	60 lb.

▲ Units with "D" prefix have duplex cavities.

* Old style FLEXIDYNE sizes.

Bulk FLEXIDYNE Flow Charge Size 70 and Up

Wt. (Lbs.)	Cast Steel Part No.	Stainless Part No.
15	311112
20	315111
25	311113



FLEXIDYNE

Stock Sheaves For FLEXIDYNE Drives (Refer To Information On Page PT3-18)

For FLEXIDYNE Size	Fig. No. (page PT3-18)	No. of Grvs.	Datum Dia.			Outside Dia.		Bolt-On Part No.	TAPER LOCK Part No.	QD Part No.	Wt. (Lbs) ▲	See Drwg's on Page PT3-18			
			Using A Belts ★	Using B Belts ★	Using C Belts ★	Using 3V Belts	Using 5V Belts					E	F	L	M
5D Sheaves are integral - included in price & wt. of assembled unit															
55D	1 or 2	1	3.35	112175	1.1	0.69	0.31
		1	3.65	112176	455108	1.5	0.56	0.69	0.31
		1	4.12	112177	144109	2.2	0.56	0.69	0.31
		1	4.5	112178	144110	2.4	0.56	0.69	0.31
		1	5.0	112180	455112	2.9	0.56	0.69	0.31
		1	5.3	112181	455113	3.4	0.56	0.69	0.31
		1	5.6	112182	455114	3.8	0.56	0.69	0.31
		1	6.0	112183	455115	4.1	0.56	0.69	0.31
	1	6.5	112184	455116	4.5	0.56	0.69	0.31	
	1	6.9	112185	455117	5.1	0.56	0.69	0.31	
	1	3.0	3.4 ■	118283	118283	1.2	0.50	0.88	0.00
	1	3.2	3.6 ■	118284	118284	1.3	0.50	0.88	0.00	0.00
	1	3.4	3.8 ■	118301	118285	1.6	0.50	0.88	0.00	0.00
	1	3.6	4.0 ■	118302	118286	1.8	0.25	0.88	0.19	0.00
	1	3.8	4.2 ■	118194	455550	2.2	0.25	0.88	0.19	0.13
	1	4.0	4.4 ■	118195	455551	2.6	0.25	0.88	0.19	0.13
1	4.2	4.6	118196	2.1	0.88	0.13	
1	4.4	4.8	118197	2.4	0.88	0.13	
1	4.6	5.0	118198	3.6	0.88	0.13	
1	4.8	5.2	118199	3.8	0.88	0.13	
1	5.0	5.4	118200	...	3.1	0.88	0.13	
1	5.2	5.6	118201	...	4.3	0.88	0.13	
1	5.4	5.8	118202	...	4.1	0.88	0.13	
1	5.6	6.0	118203	...	4.1	0.88	0.13	
1	5.8	6.2	118204	...	4.3	...	0.88	0.13	
1	6.0	6.4	118205	...	4.1	0.88	0.13	
1	6.2	6.6	118206	...	4.9	0.88	0.13	
1	6.4	6.8	118207	...	4.8	...	0.88	0.13	
70D	4	1	4.75	112250	...	2.2	0.13	0.69	0.44	0.13
		1	5.0	112251	...	2.5	0.13	0.69	0.44	0.13
		1	5.3	112252	...	3.1	0.13	0.69	0.44	0.13
		1	5.6	112253	...	3.3	0.13	0.69	0.44	0.13
		1	6.0	112254	...	3.8	0.00	0.69	0.56	0.13
		1	6.5	112255	...	4.6	0.00	0.69	0.56	0.13
		1	6.9	112256	...	5.4	0.00	0.69	0.56	0.13
	1	4.8	5.2	118275	...	2.7	0.19	0.88	0.44	0.25	
	1	5.0	5.4	118276	...	3.2	0.19	0.88	0.44	0.25	
	1	5.2	5.6	118277	...	3.7	0.19	0.88	0.44	0.25	
	1	5.6	6.0	118278	...	4.5	0.19	0.88	0.44	0.25	
	1	6.0	6.4	118279	...	5.3	0.28	0.88	0.22	0.38	
	1	6.4	6.8	118280	...	6.2	0.28	0.88	0.22	0.38	
	1	7.0 ◆	7.4 ◆	118281	...	10.9	0.25	1.00	0.50	0.25	

★ Composite groove to accommodate either A or B belts

† These sizes also fit 70D

◆ Made to order sheaves, price on application

▲ Use "B" Dyna-Cog Belt, not standard "B"

■ Weight does not include bushing. Order from page PT3-18

FEATURES/BENEFITS PAGE PT3-2	SPECIFICATION PAGE PT3-3	SELECTION PAGE PT3-4	ENGINEERING/TECHNICAL PAGE PT3-26
---------------------------------	-----------------------------	-------------------------	--------------------------------------



FLEXIDYNE

Stock Sheaves For FLEXIDYNE Drives (Refer To Information On Page PT3-18)

For FLEXIDYNE Size	Drwg. Ref Fig. No.	No. of Grvs.	Datum Dia.			Outside Dia.		Bolt-On Part No.	TAPER LOCK Part No.	QD Part No.	Wt. (Lbs) ▲	See Drwg's on Page PT3-18					
			Using A Belts ★	Using B Belts ★	Using C Belts ★	Using 3V Belts	Using 5V Belts					E	F	L	M		
75D	4	2	4.75	...	112265	2.2	0.13	1.09	0.69	0.28		
		2	5.0†	...	112266	2.7	0.13	1.09	0.69	0.28		
		2	5.3	...	112267	3.6	0.13	1.09	0.69	0.28		
		2	5.6†	...	112268	4.0	0.13	1.09	0.69	0.28		
		2	6.0†	...	112269	4.9	0.00	1.09	0.81	0.28		
		2	6.5	...	112270	6.1	0.00	1.09	0.81	0.28		
		2	6.9	...	112271	7.5	0.00	1.09	0.81	0.28		
	4	2	4.8	5.2	118290	4.6	0.06	1.75	0.75	0.94		
		2	5.0	5.4	118291	5.5	0.06	1.75	0.75	0.94		
		2	5.2	5.6	118292	6.5	0.06	1.75	0.75	0.94		
		2	5.6	6.0	118293	7.0	0.06	1.75	0.75	0.94		
		2	6.0	6.4	118294	7.9	0.06	1.75	0.75	0.94		
		2	6.4	6.8	118295	8.9	0.06	1.75	0.75	0.94		
		2	7.0◆	7.4◆	118296	13.3	0.00	1.75	0.81	0.94		
9D	3	4	4.75	...	310077	4.5	0.00	1.91	2.13	0.22		
		4	5.3	...	310078	5.6	0.00	1.91	2.13	0.22		
		4	6.0	...	310079	8.6	0.00	1.91	2.13	0.22		
	3	4	5.6	6.0	310060	13.2	1.25	3.25	2.25	0.25		
		4	6.0	6.4	310061	15.0	1.25	3.25	2.25	0.25		
		5	5.0	5.4	310062	11.4	2.00	4.00	2.25	0.25		
		5	5.2	5.6	310063	12.3	2.00	4.00	2.25	0.25		
		11D, 11DL	4	3	7.5	310082	10.7	0.63	2.38	0.75	1.00
				5	6.5	...	310080	7.6	0.56	2.31	0.75	1.00
5	6.9	...	310081	8.7	0.56	2.31	0.75	1.00		
4	5		6.2	6.6	310064	13.7	1.63	4.00	0.75	1.63		
	5		6.4	6.8	310065	14.0	1.63	4.00	0.75	1.63		
	5		7.0	7.4	310066	18.0	1.63	4.00	0.75	1.63		
	5		8.2	8.6	310067	23.0	1.63	4.00	0.75	1.63		
15D	4		4	9.75	310085	19.8	0.56	3.06	0.75	1.75	
			5	8.5	310083	16.4	1.25	3.75	0.75	1.75	
			5	9.0	310084	18.6	1.25	3.75	0.75	1.75	
	4		5	10.5	310068	37.0	2.75	5.38	0.75	1.88	
		6	9.0	310069	31.0	2.75	6.38	0.75	2.88		
		6	9.5	310070	33.8	2.75	6.38	0.75	2.88		
		6	10.0	310071	40.0	2.75	6.38	0.75	2.88		
		18D															

Not Stocked, See Made-To-Order Sheaves on Next Page

★ Composite groove to accommodate either A or B belts.

◆ Made to order sheaves, price on application.

† These sizes also fit 70D.

▲ Weight does not include bushing. Order from next page.

FEATURES/BENEFITS PAGE PT3-2	SPECIFICATION PAGE PT3-3	SELECTION PAGE PT3-4	ENGINEERING/TECHNICAL PAGE PT3-26
---------------------------------	-----------------------------	-------------------------	--------------------------------------



FLEXIDYNE

The tables on the previous pages list stock sheaves available for use on FLEXIDYNE Drives from size 55D thru 15D. The size 5D uses integral sheaves which are shown on page PT3-8. The 18D sheaves are made-to-order.

Avoid the use of bored-to-size sheaves which use setscrews which may distort sleeve or damage bearings. Order sheaves by part number listed in tables on previous pages PT3-16 - PT3-17. Refer to V-Drive tables on Pages PT3-18 - PT3-24. Information on made-to-order sheaves is shown below

FLEXIDYNE Sheave Bushings

Dwg. Ref.	Bush. Type	Part Number	Wt. (Lbs.)	Size
Fig. 1	QD	* 120580	.6	SH x 1-11/16
Fig. 2	TAPER-LOCK	* 117071	.5	1610 x 1-11/16

* These bushings used with 55D FLEXIDYNE. Must be used without key

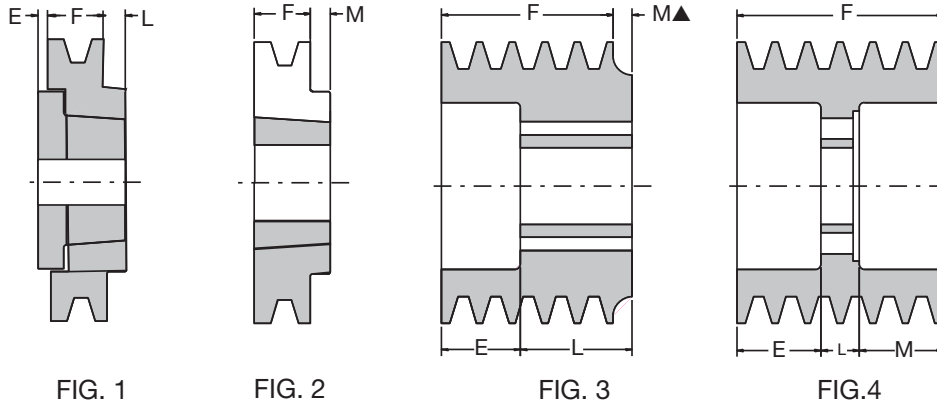

▲ Locate right side of M dimension shown here @ right end of G dimension as shown in drawing for size 9D on page PT3-8

Made-To-Order FLEXIDYNE Sheaves

For FLEXIDYNE Mech. Size	Separate Sheaves				
	Max. No. Grvs	Belt Size	Min. Dia.* TAPER-LOCK	QD	Bolt-On
55D	1	3V	3.85
		A	3.8	3.0	...
		B	4.2	3.4	...
70D	1	3V	5.3
		A	4.8
		B	5.2
75D	2	3V	5.3
		A	4.8
		B	5.2
9D	7	3V	6.4	...	4.75★
		B	6.6	...	5.4◆
11D, 11DL	10	3V	6.6
	6	5V	7.5
	7	B	6.7
15D	15	3V	8.0
	9	5V	9.0
	9	B	8.0
	7	C	8.5
18D	13	5V	11.8
	10	C	11.0

* For 3V, 5V groove sheaves outside diameter is shown. For A, B and C groove sheaves, pitch diameter is shown."

★ TAPER-LOCK furnished for 6.4 and larger O.D.

◆ TAPER-LOCK furnished for 6.6 and larger P.D.

Stock FLEXIDYNE sheaves should be used whenever possible. However Made-to-Order sheaves which conform to diameter and groove limitations listed in table at left, can be furnished. Consult DODGE if sheave required does not fall within these limits.

Made-to-order sheaves will be priced on application. Consult DODGE for price and delivery. The following should be included with your inquiry:

1. Style of Sheave (Bolt-on, Integral, TAPER-LOCK, etc.)
2. No. of Grooves.
3. Belt Size.
4. Sheave Dia. (State whether O.D. or P.D.)
5. Quantity Req'd.

FEATURES/BENEFITS PAGE PT3-2	SPECIFICATION PAGE PT3-3	SELECTION PAGE PT3-4	ENGINEERING/TECHNICAL PAGE PT3-26
---------------------------------	-----------------------------	-------------------------	--------------------------------------



FLEXIDYNE DS

These are typical drives for average service conditions

Driven by 1750 RPM Motors					Driven by 1750 RPM Motors				
Driven RPM	V-Belt Drive Ratio	Sheave		Quan. & Belt Size ◆	Driven RPM	V-Belt Drive Ratio	Sheave		Quan. & Belt Size ◆
		Driver ▲	Driven *				Driver ▲	Driven *	
2250	1.29	3.6	AK30H	1-4L	1122	1.56	3.6	5.6	**
2122	1.22	3.4	AK30H	1-4L	1117	1.57	3.0	AK51H	1-4L
2100	1.20	3.6	AK32H	1-4L	1105	1.58	3.6	AK61H	1-4L
1970	1.13	3.6	AK34H	1-4L	1048	1.67	3.0	AK54H	1-4L
1970	1.13	3.4	AK32H	1-4L	1012	1.73	3.0	AK56H	1-4L
1875	1.07	3.0	AK30H	1-4L	1008	1.74	3.4	BK65H	1-5L
1850	1.06	3.6	3.4	**	983	1.78	3.6	6.4	**
1850	1.06	3.4	AK34H	1-4L	955	1.83	3.0	AK59H	1-4L
1750	1.00	3.0	AK32H	1-4L	936	1.87	3.0	5.6	**
1707	1.03	4.0	BK47H	1-5L	930	1.88	3.4	BK70H	1-5L
1703	1.03	3.6	AK41H	1-4L	921	1.90	3.0	AK61H	1-4L
1651	1.06	3.6	3.8	**	900	1.94	3.6	AK74H	1-4L
1651	1.06	3.4	BK40H	1-5L	875	2.00	3.0	AK64H	1-4L
1640	1.07	3.0	AK34H	1-4L	833	2.10	4.0	BK90H	1-5L
1577	1.11	3.6	AK44H	1-4L	804	2.18	3.4	BK80H	1-5L
1572	1.11	4.0	BK50H	1-5L	788	2.22	3.6	AK84H	1-4L
1615	1.08	3.6	BK45H	1-5L	768	2.28	3.6	8.2	**
1544	1.13	3.0	3.4	**	751	2.33	3.0	AK74H	1-4L
1525	1.15	3.4	BK45H	1-5L	708	2.47	3.4	BK90H	1-5L
1496	1.17	3.6	AK46H	1-4L	700	2.50	3.6	AK94H	1-4L
1522	1.15	4.0	BK52H	1-5L	673	2.60	4.0	BK110H	1-5L
1458	1.20	3.0	3.6	**	656	2.67	3.0	AK84H	1-4L
1451	1.21	3.4	BK47H	1-5L	641	2.73	3.0	8.2	**
1429	1.23	4.0	BK55H	1-5L	630	2.78	3.6	AK104H	1-4L
1400	1.25	3.6	AK49H	1-4L	614	2.85	4.0	BK120H	1-5L
1423	1.23	3.0	AK41H	1-4L	595	2.94	3.6	10.6	**
1378	1.27	3.0	3.8	**	583	3.00	3.0	AK94H	1-4L
1376	1.28	3.6	4.6	**	572	3.06	3.4	BK110H	1-5L
1372	1.28	4.0	BK57H	1-5L	525	3.33	3.0	AK104H	1-4L
1316	1.33	3.6	4.8	**	496	3.53	3.0	10.6	**
1340	1.31	3.6	AK51H	1-4L	455	3.85	4.0	BK160H	1-5L
1313	1.33	3.0	AK44H	1-4L	450	3.89	3.6	AK144H	1-4L
1296	1.35	4.0	BK60H	1-5L	444	3.94	3.4	BK140H	1-5L
1293	1.35	3.4	BK52H	1-5L	438	4.00	3.0	AK124H	1-4L
1259	1.39	3.6	AK54H	1-4L	420	4.17	3.6	AK154H	1-4L
1250	1.40	3.0	AK46H	1-4L	386	4.53	3.4	BK160H	1-5L
1215	1.44	3.6	AK56H	1-4L	375	4.67	3.0	AK144H	1-4L
1214	1.44	3.4	BK55H	1-5L	350	5.00	3.0	AK154H	1-4L
1186	1.48	4.0	BK65H	1-5L	323	5.41	3.4	BK190H	1-5L
1167	1.50	3.0	AK49H	1-4L	292	6.00	3.0	AK184H	1-4L
1167	1.50	3.4	BK57H	1-5L					
1145	1.58	3.6	AK59H	1-4L					

** Use one belt, either A or 4L.

▲ Pitch diameter of integral sheaves supplied with stock 5D-FLEXIDYNE.

◆ "A" Belts may be used in place of 4L belts on 3.0 P.D. sheaves or larger.

"AX" Belts may be used in place of 4L belts on 2.2 P.D. sheaves or larger.

"B" Belts are not recommended in place of 5L belts.

"BX" Belts may be used in place of 5L belts on 4.0 P.D. sheaves or larger.

* All Sheaves are DODGE stock sheaves. Size numbers are shown for FHP 4L and 5L sheaves; datum diameters for Dual Duty sheaves.

FEATURES/BENEFITS PAGE PT3-2	SPECIFICATION PAGE PT3-3	SELECTION PAGE PT3-4	ENGINEERING/TECHNICAL PAGE PT3-26
---------------------------------	-----------------------------	-------------------------	--------------------------------------



FLEXIDYNE V-Belt Drives For 55D FLEXIDYNE Drives

These are typical drives for average service conditions

Driven by 1750 RPM Motors					Driven by 1750 RPM Motors				
Driven RPM	V-Belt Drive Ratio	Diameter ★		Quan. & Belt Size ◆	Driven RPM	V-Belt Drive Ratio	Diameter ★		Quan. & Belt Size ◆
		Driver *	Driven ▲				Driver *	Driven ▲	
1750	1.00	3.6	3.6	1-A	1160	1.00	3.0	3.0	1-A
1750	1.00	3.4	3.4	1-3V	1160	1.00	3.4	3.4	1-3V
1670	1.05	4.2	4.4	1-A	1112	1.04	4.6	4.8	1-B
1657	1.06	4.5	4.8	1-3V	1098	1.06	4.5	4.8	1-3V
1598	1.10	4.2	4.6	1-A	1059	1.10	4.2	4.6	1-A
1573	1.11	4.5	5.0	1-3V	1061	1.09	4.1	4.5	1-3V
1522	1.15	4.0	4.6	1-A	1036	1.12	5.0	5.6	1-B
1515	1.15	4.1	4.8	1-3V	1026	1.13	3.7	4.1	1-3V
1483	1.18	4.5	5.3	1-3V	1005	1.15	4.1	4.8	1-3V
1470	1.19	4.2	5.0	1-A	1002	1.16	3.8	4.4	1-A
1439	1.22	4.1	5.0	1-3V	958	1.21	3.8	4.6	1-A
1411	1.24	5.0	6.2	1-B	954	1.22	4.1	5.0	1-3V
1403	1.25	4.5	5.6	1-3V	928	1.25	3.2	4.0	1-A
1357	1.29	4.1	5.3	1-3V	930	1.25	4.5	5.6	1-3V
1342	1.30	4.6	6.0	1-B	899	1.29	4.1	5.3	1-3V
1309	1.34	4.5	6.0	1-3V	892	1.30	4.0	5.2	1-A
1298	1.35	4.6	6.2	1-B	868	1.34	4.5	6.0	1-3V
1273	1.37	3.7	5.0	1-3V	859	1.35	4.0	5.4	1-A
1250	1.40	4.0	5.6	1-A	844	1.37	3.7	5.0	1-3V
1229	1.42	3.4	4.8	1-3V	840	1.38	4.2	5.8	1-A
1207	1.45	4.0	5.8	1-A	816	1.42	3.8	5.4	1-A
1197	1.46	4.1	6.0	1-3V	814	1.42	3.4	4.8	1-3V
1182	1.48	5.0	7.4	1-B	800	1.45	4.5	6.5	1-3V
1167	1.50	3.4	5.0	1-3V	791	1.47	3.0	4.4	1-A
1135	1.54	3.7	5.6	1-3V	773	1.50	3.2	4.8	1-A
1129	1.55	4.0	6.2	1-A	773	1.50	3.4	5.0	1-3V
1100	1.59	3.4	5.3	1-3V	757	1.53	3.0	4.6	1-A
1094	1.60	4.0	6.4	1-A	754	1.54	4.5	6.9	1-3V
1073	1.63	3.8	6.2	1-A	746	1.56	3.6	5.6	1-A
1059	1.65	3.7	6.0	1-3V	730	1.59	3.4	5.4	1-A
1041	1.68	3.4	5.6	1-3V	729	1.59	3.4	5.3	1-3V
1026	1.71	3.4	5.8	1-A	711	1.63	3.8	6.2	1-A
1000	1.75	4.0	7.0	1-A	702	1.65	3.7	6.0	1-3V
980	1.79	4.5	8.0	1-3V	696	1.67	3.0	5.0	1-A
960	1.82	3.4	6.2	1-A	690	1.68	3.4	5.6	1-3V
936	1.87	4.6	8.6	1-B	680	1.71	3.4	5.8	1-A
920	1.90	3.7	6.9	1-3V	649	1.79	4.5	8.0	1-3V
900	1.94	3.6	7.0	1-A	644	1.80	3.0	5.4	1-A
895	1.95	3.4	6.5	1-3V	616	1.88	3.4	6.4	1-A
850	2.06	3.4	7.0	1-A	610	1.90	3.7	6.9	1-3V
843	2.08	3.4	6.9	1-3V	593	1.95	3.4	6.5	1-3V
795	2.20	5.0	11.0	1-B	580	2.00	3.0	6.0	1-A
792	2.21	3.7	8.0	1-3V	559	2.08	3.4	6.9	1-3V
759	2.30	4.6	10.6	1-A	544	2.13	3.0	6.4	1-A
726	2.41	3.4	8.2	1-A	527	2.20	5.0	11.0	1-B
726	2.41	3.4	8.0	1-3V	525	2.21	3.7	8.0	1-3V
693	2.52	4.2	10.6	1-A	503	2.30	4.6	10.6	1-A
675	2.59	4.1	10.6	1-3V	489	2.37	4.5	10.6	1-3V
671	2.61	4.6	12.0	1-A	481	2.41	3.4	8.2	1-A
627	2.79	3.8	10.6	1-A	482	2.41	3.4	8.0	1-3V
597	2.93	3.7	10.6	1-3V	448	2.59	4.1	10.6	1-3V
583	3.00	4.0	12.0	1-A	445	2.61	4.6	12.0	1-A
558	3.13	4.5	14.0	1-3V	406	2.86	4.2	12.0	1-A
537	3.26	4.6	15.0	1-A	396	2.93	3.7	10.6	1-3V
511	3.43	4.1	14.0	1-3V	372	3.12	3.4	10.6	1-A
496	3.53	3.4	12.0	1-A	370	3.13	4.5	14.0	1-3V
476	3.68	5.0	18.4	1-B	346	3.35	4.6	15.4	1-B
452	3.87	3.7	14.0	1-3V	338	3.43	4.1	14.0	1-3V
443	3.95	3.8	15.0	1-A	309	3.75	3.2	12.0	1-A
420	4.17	3.6	15.0	1-A	299	3.87	3.7	14.0	1-3V
411	4.26	4.5	19.0	1-3V	278	4.17	3.6	15.0	1-A
397	4.41	3.4	15.0	1-A	274	4.23	3.4	14.0	1-3V
376	4.66	4.1	19.0	1-3V	258	4.50	4.0	18.0	1-A
369	4.74	3.8	18.0	1-A	249	4.66	4.1	19.0	1-3V
350	5.00	3.6	18.0	1-A	219	5.29	3.4	18.0	1-A
331	5.29	3.4	18.0	1-A	220	5.26	3.7	19.0	1-3V
332	5.26	3.7	19.0	1-3V	202	5.74	3.4	19.0	1-3V
305	5.74	3.4	19.0	1-3V	193	6.00	3.0	18.0	1-A

* Stock FLEXIDYNE sheaves listed on page PT3-16 - PT3-17.

★ Outside diameter of 3V DYNA-V sheaves. Datum diameter of A and B sheaves. All ratios are based on P.D. for DYNA-V Sheaves and Datum diameter for A and B Sheaves.

* Stock TAPER-LOCK sheaves in V-drives section.

FEATURES/BENEFITS PAGE PT3-2	SPECIFICATION PAGE PT3-3	SELECTION PAGE PT3-4	ENGINEERING/TECHNICAL PAGE PT3-26
---------------------------------	-----------------------------	-------------------------	--------------------------------------



FLEXIDYNE V-Belts Drive For 70D FLEXIDYNE Drives

These are typical drives for average service conditions

Driven RPM	V-Belt Drive Ratio	Driven by 1750 RPM Motors			Driven RPM	V-Belt Drive Ratio	Driven by 1750 RPM Motors		
		Diameter ★		Quan. & Belt Size ◆			Diameter ★		Quan. & Belt Size ◆
		Driver *	Driven ▲				Driver *	Driven ▲	
1750	1.00	5.6	5.6	1-B	1160	1.00	4.8	4.8	1-A
1694	1.03	6.0	6.2	1-B	1123	1.03	6.0	6.2	1-B
1690	1.04	5.6	5.8	1-B	1119	1.04	5.4	5.6	1-B
1641	1.07	6.0	6.4	1-B	1094	1.06	5.0	5.3	1-3V
1633	1.07	5.6	6.0	1-B	1083	1.07	5.6	6.0	1-B
1632	1.07	5.6	6.0	1-3V	1082	1.07	5.6	6.0	1-3V
1614	1.08	6.0	6.5	1-3V	1070	1.08	6.0	6.5	1-3V
1591	1.10	6.0	6.6	1-B	1055	1.10	6.0	6.6	1-B
1581	1.11	5.6	6.2	1-B	1040	1.12	5.2	5.8	1-B
1575	1.11	5.4	6.0	1-B	1035	1.12	5.0	5.6	1-3V
1544	1.13	6.0	6.8	1-B	1015	1.14	5.6	6.4	1-B
1531	1.14	5.6	6.4	1-B	1008	1.15	6.0	6.9	1-3V
1524	1.15	5.4	6.2	1-B	998	1.16	5.6	6.5	1-3V
1520	1.15	6.0	6.9	1-3V	994	1.17	4.8	5.6	1-A
1506	1.16	5.6	6.5	1-3V	967	1.20	5.0	6.0	1-A
1485	1.18	5.6	6.6	1-B	965	1.20	5.0	6.0	1-3V
1477	1.19	5.4	6.4	1-B	949	1.22	5.4	6.6	1-B
1441	1.21	5.6	6.8	1-B	940	1.23	5.6	6.9	1-3V
1432	1.22	5.4	6.6	1-B	928	1.25	4.8	6.0	1-A
1419	1.23	6.0	7.4	1-B	914	1.27	5.2	6.6	1-B
1418	1.23	5.6	6.9	1-3V	898	1.29	4.8	6.2	1-A
1390	1.26	5.4	6.8	1-B	890	1.30	5.0	6.5	1-3V
1324	1.32	5.6	7.4	1-B	878	1.32	5.6	7.4	1-B
1310	1.34	6.0	8.0	1-3V	868	1.34	6.0	8.0	1-3V
1265	1.38	5.0	6.9	1-3V	862	1.35	5.2	7.0	1-A
1221	1.43	6.0	8.6	1-B	846	1.37	5.4	7.4	1-B
1222	1.43	5.6	8.0	1-3V	838	1.38	5.0	6.9	1-3V
1140	1.54	5.6	8.6	1-B	829	1.40	5.0	7.0	1-A
1117	1.57	6.0	9.4	1-B	809	1.43	6.0	8.6	1-B
1099	1.59	5.4	8.6	1-B	810	1.43	5.6	8.0	1-3V
1090	1.61	5.0	8.0	1-3V	792	1.46	5.6	8.2	1-A
1058	1.65	5.2	8.6	1-B	755	1.54	5.6	8.6	1-B
1043	1.68	5.6	9.4	1-B	740	1.57	6.0	9.4	1-B
1005	1.74	5.4	9.4	1-B	722	1.61	5.6	9.0	1-A
987	1.77	6.0	10.6	1-3V	722	1.61	5.0	8.0	1-3V
968	1.81	5.2	9.4	1-B	701	1.65	5.2	8.6	1-B
955	1.83	6.0	11.0	1-B	679	1.71	4.8	8.2	1-A
921	1.90	5.6	10.6	1-3V	666	1.74	5.4	9.4	1-B
891	1.96	5.6	11.0	1-B	654	1.77	6.0	10.6	1-3V
859	2.04	5.4	11.0	1-B	644	1.80	5.0	9.0	1-A
847	2.07	6.0	12.4	1-B	613	1.89	5.6	10.6	1-A
827	2.12	5.2	11.0	1-B	610	1.90	5.6	10.6	1-3V
821	2.13	5.0	10.6	1-3V	591	1.96	5.6	11.0	1-B
790	2.21	5.6	12.4	1-B	569	2.04	5.4	11.0	1-B
762	2.30	5.4	12.4	1-B	548	2.12	5.2	11.0	1-B
746	2.34	6.0	14.0	1-3V	544	2.13	5.0	10.6	1-3V
734	2.38	5.2	12.4	1-B	525	2.21	4.8	10.6	1-A
696	2.51	5.6	14.0	1-3V	505	2.30	5.4	12.4	1-B
682	2.57	6.0	15.4	1-B	495	2.34	6.0	14.0	1-3V
636	2.75	5.6	15.4	1-B	486	2.38	5.2	12.4	1-B
621	2.82	5.0	14.0	1-3V	464	2.50	4.8	12.0	1-A
614	2.85	5.4	15.4	1-B	462	2.51	5.6	14.0	1-3V
609	2.87	6.4	18.4	1-B	452	2.57	6.0	15.4	1-B
591	2.96	5.2	15.4	1-B	433	2.68	5.6	15.0	1-A
571	3.07	6.0	18.4	1-B	422	2.75	5.6	15.4	1-B
549	3.18	6.0	19.0	1-3V	412	2.82	5.0	14.0	1-3V
533	3.29	5.6	18.4	1-B	402	2.88	5.2	15.0	1-A
514	3.41	5.4	18.4	1-B	392	2.96	5.2	15.4	1-B
513	3.41	5.6	19.0	1-3V	387	3.00	5.0	15.0	1-A
495	3.54	5.2	18.4	1-B	371	3.12	4.8	15.0	1-A
457	3.83	5.0	19.0	1-3V	364	3.18	6.0	19.0	1-3V
.....	361	3.21	5.6	18.0	1-A
.....	353	3.29	5.6	18.4	1-B
.....	340	3.41	5.6	19.0	1-3V
.....	335	3.46	5.2	18.0	1-A
.....	322	3.60	5.0	18.0	1-A
.....	309	3.75	4.8	18.0	1-A
.....	303	3.83	5.0	19.0	1-3V

* Stock FLEXIDYNE sheaves listed on page PT3-16 - PT3-17.

★ Outside diameter of 3V DYNA-V sheaves. Datum diameter of A and B sheaves. All ratios are based on P.D. for DYNA-V Sheaves and Datum diameter for A and B Sheaves.

* Stock TAPER-LOCK sheaves in V-drives section.

FEATURES/BENEFITS PAGE PT3-2	SPECIFICATION PAGE PT3-3	SELECTION PAGE PT3-4	ENGINEERING/TECHNICAL PAGE PT3-26
---------------------------------	-----------------------------	-------------------------	--------------------------------------



FLEXIDYNE

V-Belt Drives For 75D FLEXIDYNE Drives

These are typical drives for average service conditions

Driven by 1750 RPM Motors					Driven by 1750 RPM Motors				
Driven RPM	V-Belt Drive Ratio	Diameter ★		Quan. & Belt Size ◆	Driven RPM	V-Belt Drive Ratio	Diameter ★		Quan. & Belt Size ◆
		Driver *	Driven ⬆				Driver *	Driven ⬆	
1750	1.00	5.6	5.6	2-B	1160	1.00	4.8	4.8	2-A
1694	1.03	6.0	6.2	2-B	1114	1.04	4.8	5.0	2-A
1690	1.04	5.6	5.8	2-B	1094	1.06	5.0	5.3	2-3V
1641	1.07	6.0	6.4	2-B	1082	1.07	5.6	6.0	2-3V
1632	1.07	5.6	6.0	2-3V	1071	1.08	4.8	5.2	2-A
1614	1.08	6.0	6.5	2-3V	1072	1.08	6.0	6.5	2-3V
1591	1.10	6.0	6.6	2-B	1055	1.10	6.0	6.6	2-B
1544	1.13	6.0	6.8	2-B	1036	1.12	5.0	5.6	2-A
1524	1.15	5.4	6.2	2-B	1035	1.12	5.0	5.6	2-3V
1520	1.15	6.0	6.9	2-3V	1015	1.14	5.6	6.4	2-B
1506	1.16	5.6	6.5	2-3V	1008	1.15	6.0	6.9	2-3V
1485	1.18	5.6	6.6	2-B	1000	1.16	5.0	5.8	2-A
1441	1.21	5.6	6.8	2-B	998	1.16	5.6	6.5	2-3V
1419	1.23	6.0	7.4	2-B	994	1.17	4.8	5.6	2-A
1418	1.23	5.6	6.9	2-3V	984	1.18	5.6	6.6	2-B
1390	1.26	5.4	6.8	2-B	967	1.20	5.0	6.0	2-A
1324	1.32	5.6	7.4	2-B	965	1.20	5.0	6.0	2-3V
1310	1.34	6.0	8.0	2-3V	960	1.21	4.8	5.8	2-A
1277	1.37	5.4	7.4	2-B	941	1.23	6.0	7.4	2-B
1265	1.38	5.0	6.9	2-3V	940	1.23	5.6	6.9	2-3V
1221	1.43	6.0	8.6	2-B	935	1.24	5.0	6.2	2-A
1222	1.43	5.6	8.0	2-3V	928	1.25	4.8	6.0	2-A
1140	1.54	5.6	8.6	2-B	906	1.28	5.0	6.4	2-A
1117	1.57	6.0	9.4	2-B	898	1.29	4.8	6.2	2-A
1099	1.59	5.4	8.6	2-B	890	1.30	5.0	6.5	2-3V
1090	1.61	5.0	8.0	2-3V	887	1.31	5.2	6.8	2-B
1043	1.68	5.6	9.4	2-B	870	1.33	4.8	6.4	2-A
1005	1.74	5.4	9.4	2-B	868	1.34	6.0	8.0	2-3V
987	1.77	6.0	10.6	2-3V	862	1.35	5.2	7.0	2-A
968	1.81	5.2	9.4	2-B	846	1.37	5.4	7.4	2-B
955	1.83	6.0	11.0	2-B	838	1.38	5.0	6.9	2-3V
921	1.90	5.6	10.6	2-3V	829	1.40	5.0	7.0	2-A
891	1.96	5.6	11.0	2-B	809	1.43	6.0	8.6	2-B
859	2.04	5.4	11.0	2-B	810	1.43	5.6	8.0	2-3V
847	2.07	6.0	12.4	2-B	795	1.46	4.8	7.0	2-A
827	2.12	5.2	11.0	2-B	755	1.54	5.6	8.6	2-B
821	2.13	5.0	10.6	2-3V	736	1.58	5.2	8.2	2-A
790	2.21	5.6	12.4	2-B	722	1.61	5.0	8.0	2-3V
762	2.30	5.4	12.4	2-B	707	1.64	5.0	8.2	2-A
746	2.34	6.0	14.0	2-3V	679	1.71	4.8	8.2	2-A
734	2.38	5.2	12.4	2-B	670	1.73	5.2	9.0	2-A
696	2.51	5.6	14.0	2-3V	654	1.77	6.0	10.6	2-3V
682	2.57	6.0	15.4	2-B	644	1.80	5.0	9.0	2-A
636	2.75	5.6	15.4	2-B	619	1.87	4.8	9.0	2-A
621	2.82	5.0	14.0	2-3V	610	1.90	5.6	10.6	2-3V
614	2.85	5.4	15.4	2-B	591	1.96	5.6	11.0	2-B
591	2.96	5.2	15.4	2-B	569	2.04	5.4	11.0	2-B
571	3.07	6.0	18.4	2-B	547	2.12	5.0	10.6	2-A
549	3.18	6.0	19.0	2-3V	544	2.13	5.0	10.6	2-3V
525	3.33	6.0	20.0	2-B	525	2.21	4.8	10.6	2-A
514	3.41	5.4	18.4	2-B	495	2.34	6.0	14.0	2-3V
513	3.41	5.6	19.0	2-3V	486	2.38	5.2	12.4	2-B
490	3.57	5.6	20.0	2-B	464	2.50	4.8	12.0	2-A
455	3.85	5.2	20.0	2-B	462	2.51	5.6	14.0	2-3V
457	3.83	5.0	19.0	2-3V	422	2.75	5.6	15.4	2-B
420	4.17	6.0	25.0	2-B	412	2.82	5.0	14.0	2-3V
417	4.19	6.0	25.0	2-3V	402	2.88	5.2	15.0	2-A
392	4.46	5.6	25.0	2-B	387	3.00	5.0	15.0	2-A
389	4.50	5.6	25.0	2-3V	371	3.12	4.8	15.0	2-A
378	4.63	5.4	25.0	2-B	364	3.18	6.0	19.0	2-3V
364	4.81	5.2	25.0	2-B	340	3.41	5.6	19.0	2-3V
350	5.00	6.0	30.0	2-B	322	3.60	5.0	18.0	2-A
347	5.04	5.0	25.0	2-3V	309	3.75	4.8	18.0	2-A
327	5.36	5.6	30.0	2-B	303	3.83	5.0	19.0	2-3V
303	5.77	5.2	30.0	2-B	278	4.17	6.0	25.0	2-B
276	6.33	6.0	38.0	2-B	277	4.19	6.0	25.0	2-3V
258	6.79	5.6	38.0	2-B	258	4.50	5.6	25.0	2-3V
249	7.04	5.4	38.0	2-B	230	5.04	5.0	25.0	2-3V

* Stock FLEXIDYNE sheaves listed on page PT3-16 - PT3-17.

★ Outside diameter of 3V DYNA-V sheaves. Datum diameter of A and B sheaves. All ratios are based on P.D. for DYNA-V Sheaves and Datum diameter for A and B Sheaves.

* Stock TAPER-LOCK sheaves in V-drives section.

FEATURES/BENEFITS PAGE PT3-2	SPECIFICATION PAGE PT3-3	SELECTION PAGE PT3-4	ENGINEERING/TECHNICAL PAGE PT3-26
---------------------------------	-----------------------------	-------------------------	--------------------------------------



FLEXIDYNE

V-Belt Drives For 9D FLEXIDYNE Drives

These are typical drives for average service conditions

Driven by 1750 RPM Motors					Driven by 1750 RPM Motors				
Driven RPM	V-Belt Drive Ratio	Diameter ★		Quan. & Belt Size ◆	Driven RPM	V-Belt Drive Ratio	Diameter ★		Quan. & Belt Size ◆
		Driver *	Driven ▲				Driver *	Driven ▲	
1750	1.00	4.75	4.75	4-3V	1160	1.00	4.75	4.75	4-3V
1683	1.04	5.0	5.2	5-A	1115	1.04	5.0	5.2	5-A
1667	1.05	4.75	5.0	4-3V	1105	1.05	4.75	5.0	4-3V
1636	1.07	5.6	6.0	4-A	1084	1.07	5.6	6.0	4-A
1620	1.08	5.2	5.6	5-A	1074	1.08	5.2	5.6	5-A
1577	1.11	5.4	6.0	5-B	1045	1.11	5.4	6.0	5-B
1563	1.12	4.75	5.3	4-3V	1036	1.12	4.75	5.3	4-3V
1549	1.13	5.3	6.0	4-3V	1027	1.13	5.3	6.0	4-3V
1535	1.14	5.6	6.4	4-A	1018	1.14	5.6	6.4	4-A
1522	1.15	6.0	6.9	4-3V	1009	1.15	6.0	6.9	4-3V
1496	1.17	6.0	7.0	4-A	991	1.17	6.0	7.0	4-A
1483	1.18	4.75	5.6	4-3V	983	1.18	4.75	5.6	4-3V
1458	1.20	5.0	6.0	5-A	967	1.20	5.0	6.0	5-A
1423	1.23	5.3	6.5	4-3V	943	1.23	5.3	6.5	4-3V
1400	1.25	5.6	7.0	4-A	928	1.25	5.6	7.0	4-A
1378	1.27	4.75	6.0	4-3V	913	1.27	4.75	6.0	4-3V
1367	1.28	5.0	6.4	5-A	906	1.28	5.0	6.4	5-A
1346	1.30	5.3	6.9	4-3V	892	1.30	5.3	6.9	4-3V
1326	1.32	5.6	7.4	5-B	879	1.32	5.6	7.4	5-B
1306	1.34	6.0	8.0	4-3V	866	1.34	6.0	8.0	4-3V
1296	1.35	5.2	7.0	5-A	859	1.35	5.2	7.0	5-A
1277	1.37	4.75	6.5	4-3V	847	1.37	4.75	6.5	4-3V
1250	1.40	5.0	7.0	5-A	829	1.40	5.0	7.0	5-A
1224	1.43	6.0	8.6	4-B	811	1.43	6.0	8.6	4-B
1199	1.46	4.75	6.9	4-3V	795	1.46	4.75	6.9	4-3V
1159	1.51	5.3	8.0	4-3V	768	1.51	5.3	8.0	4-3V
1136	1.54	5.6	8.6	5-B	753	1.54	5.6	8.6	5-B
1108	1.58	5.2	8.2	5-A	734	1.58	5.2	8.2	5-A
1087	1.61	5.6	9.0	4-A	720	1.61	5.6	9.0	4-A
1067	1.64	5.0	8.2	5-A	707	1.64	5.0	8.2	5-A
1036	1.69	4.75	8.0	4-3V	686	1.69	4.75	8.0	4-3V
1012	1.73	5.2	9.0	5-A	671	1.73	5.2	9.0	5-A
989	1.77	6.0	10.6	4-3V	655	1.77	6.0	10.6	4-3V
972	1.80	5.0	9.0	5-A	644	1.80	5.0	9.0	5-A
956	1.83	6.0	11.0	4-B	634	1.83	6.0	11.0	4-B
926	1.89	5.6	10.6	4-A	614	1.89	5.6	10.6	4-A
902	1.94	6.4	12.4	4-B	598	1.94	6.4	12.4	4-B
871	2.01	5.3	10.6	4-3V	577	2.01	5.3	10.6	4-3V
858	2.04	5.2	10.6	5-A	569	2.04	5.2	10.6	5-A
818	2.14	5.6	12.0	4-A	542	2.14	5.6	12.0	4-A
792	2.21	5.6	12.4	5-B	525	2.21	5.6	12.4	5-B
781	2.24	4.75	10.6	4-3V	518	2.24	4.75	10.6	4-3V
748	2.34	6.0	14.0	4-3V	496	2.34	6.0	14.0	4-3V
729	2.40	5.0	12.0	5-A	483	2.40	5.0	12.0	5-A
700	2.50	6.0	12.0	4-A	464	2.50	6.0	12.0	4-A
681	2.57	6.0	15.4	4-B	451	2.57	6.0	15.4	4-B
658	2.66	5.3	14.0	4-3V	436	2.66	5.3	14.0	4-3V
636	2.75	5.6	15.4	5-B	422	2.75	5.6	15.4	5-B
608	2.88	5.2	15.0	5-A	403	2.88	5.2	15.0	5-A
589	2.97	4.75	14.0	4-3V	391	2.97	4.75	14.0	4-3A
570	3.07	6.0	18.4	4-B	378	3.07	6.0	18.4	4-B
545	3.21	5.6	18.0	4-A	361	3.21	5.6	18.0	4-A
532	3.29	5.6	18.4	5-B	353	3.29	5.6	18.4	5-B
506	3.46	5.2	18.0	5-A	335	3.46	5.2	18.0	5-A
485	3.61	5.3	19.0	4-3V	321	3.61	5.3	19.0	4-3V
473	3.70	5.4	20.0	5-B	314	3.70	5.4	20.0	5-B
448	3.91	6.4	25.0	4-B	297	3.91	6.4	25.0	4-B
434	4.03	4.75	19.0	4-3V	288	4.03	4.75	19.0	4-3V
420	4.17	6.0	25.0	4-B	278	4.17	6.0	25.0	4-B
392	4.46	5.6	25.0	5-B	260	4.46	5.6	25.0	5-B
368	4.75	5.3	25.0	4-3V	244	4.75	5.3	25.0	4-3V
350	5.00	6.0	30.0	4-B	232	5.00	6.0	30.0	4-B
330	5.31	4.75	25.0	4-3V	218	5.31	4.75	25.0	4-3V
311	5.62	6.0	33.5	4-3V	206	5.62	6.0	33.5	4-3V
295	5.94	6.4	38.0	4-B	195	5.94	6.4	38.0	4-B
275	6.37	5.3	33.5	4-3V	182	6.37	5.3	33.5	4-3V
258	6.79	5.6	38.0	5-B	171	6.79	5.6	38.0	5-B
246	7.12	4.75	33.5	4-3V	163	7.12	4.75	33.5	4-3V

* Stock FLEXIDYNE sheaves listed on page PT3-16 - PT3-17.

* Stock TAPER-LOCK sheaves in V-drives section.

★ Outside diameter of 3V DYNA-V sheaves. Datum diameter of A and B sheaves. All ratios are based on P.D. for DYNA-V Sheaves and Datum diameter for A and B Sheaves.

FEATURES/BENEFITS PAGE PT3-2	SPECIFICATION PAGE PT3-3	SELECTION PAGE PT3-4	ENGINEERING/TECHNICAL PAGE PT3-26
---------------------------------	-----------------------------	-------------------------	--------------------------------------



FLEXIDYNE

V-Belt Drives For 11D, 11DL FLEXIDYNE Drives

These are typical drives for average service conditions

Driven by 1750 RPM Motors					Driven by 1750 RPM Motors				
Driven RPM	V-Belt Drive Ratio	Diameter ★		Quan. & Belt Size ◆	Driven RPM	V-Belt Drive Ratio	Diameter ★		Quan. & Belt Size ◆
		Driver *	Driven ▲				Driver *	Driven ▲	
1750	1.00	6.5	6.5	5-3V	1160	1.00	6.5	6.5	5-3V
1750	1.00	6.8	6.8	5-B	1160	1.00	6.8	6.8	5-B
1699	1.03	6.6	6.8	5-B	1126	1.03	6.6	6.8	5-B
1651	1.06	6.5	6.9	5-3V	1094	1.06	6.5	6.9	5-3V
1636	1.07	7.5	8.0	3-5V	1084	1.07	7.5	8.0	3-5V
1606	1.09	6.8	7.4	5-B	1064	1.09	6.8	7.4	5-B
1563	1.12	6.6	7.4	5-B	1036	1.12	6.6	7.4	5-B
1535	1.14	7.5	8.5	3-5V	1022	1.14	7.5	8.5	3-5V
1509	1.16	7.4	8.6	5-B	1000	1.16	7.4	8.6	5-B
1509	1.16	6.9	8.0	5-3V	1000	1.16	6.9	8.0	5-3V
1458	1.20	7.5	9.0	3-5V	967	1.20	7.5	9.0	3-5V
1423	1.23	6.5	8.0	5-3V	943	1.23	6.5	8.0	5-3V
1411	1.24	7.5	9.25	3-5V	935	1.24	7.5	9.25	3-5V
1389	1.26	6.8	8.6	5-B	921	1.26	6.8	8.6	5-B
1378	1.27	7.4	9.4	5-B	913	1.27	7.4	9.4	5-B
1367	1.28	8.6	11.0	5-B	906	1.28	8.6	11.0	5-B
1346	1.30	7.5	9.75	3-5V	892	1.30	7.5	9.75	3-5V
1346	1.30	6.6	8.6	5-B	892	1.30	6.6	8.6	5-B
1268	1.38	7.5	10.3	3-5V	841	1.38	7.5	10.3	3-5V
1268	1.38	6.8	9.4	5-B	841	1.38	6.8	9.4	5-B
1232	1.42	6.6	9.4	5-B	817	1.42	6.6	9.4	5-B
1215	1.44	8.6	12.4	5-B	806	1.44	8.6	12.4	5-B
1199	1.46	7.5	10.9	3-5V	795	1.46	7.5	10.9	3-5V
1174	1.49	7.4	11.0	5-B	779	1.49	7.4	11.0	5-B
1136	1.54	6.9	10.6	5-3V	753	1.54	6.9	10.6	5-3V
1108	1.58	7.5	11.8	3-5V	734	1.58	7.5	11.8	3-5V
1080	1.62	6.8	11.0	5-B	716	1.62	6.8	11.0	5-B
1067	1.64	6.5	10.6	5-3V	707	1.64	6.5	10.6	5-3V
1048	1.67	6.6	11.0	5-B	695	1.67	6.6	11.0	5-B
1042	1.68	7.5	12.5	3-5V	690	1.68	7.5	12.5	3-5V
1042	1.68	7.4	12.4	5-B	690	1.68	7.4	12.4	5-B
989	1.77	7.5	13.2	3-5V	655	1.77	7.5	13.2	3-5V
978	1.79	8.6	15.4	5-B	648	1.79	8.6	15.4	5-B
962	1.82	6.8	12.4	5-B	637	1.82	6.8	12.4	5-B
931	1.88	7.5	14.0	3-5V	617	1.88	7.5	14.0	3-5V
931	1.88	6.6	12.4	5-B	617	1.88	6.6	12.4	5-B
871	2.01	7.5	15.0	3-5V	577	2.01	7.5	15.0	3-5V
858	2.04	6.9	14.0	5-3V	569	2.04	6.9	14.0	5-3V
841	2.08	7.4	15.4	5-B	558	2.08	7.4	15.4	5-B
818	2.14	8.6	18.4	5-B	542	2.14	8.6	18.4	5-B
814	2.15	7.5	16.0	3-5V	540	2.15	7.5	16.0	3-5V
810	2.16	6.5	14.0	5-3V	537	2.16	6.5	14.0	5-3V
774	2.26	6.8	15.4	5-B	513	2.26	6.8	15.4	5-B
751	2.33	6.6	15.4	5-B	498	2.33	6.6	15.4	5-B
703	2.49	7.4	18.4	5-B	466	2.49	7.4	18.4	5-B
646	2.71	6.8	18.4	5-B	428	2.71	6.8	18.4	5-B
632	2.77	6.9	19.0	5-3V	419	2.77	6.9	19.0	5-3V
627	2.79	6.6	18.4	5-B	416	2.79	6.6	18.4	5-B
614	2.85	7.5	21.2	3-5V	407	2.85	7.5	21.2	3-5V
601	2.91	8.6	25.0	5-B	399	2.91	8.6	25.0	5-B
595	2.94	6.5	19.0	5-3V	395	2.94	6.5	19.0	5-3V
578	3.03	6.6	20.0	5-B	383	3.03	6.6	20.0	5-B
518	3.38	7.4	25.0	5-B	343	3.38	7.4	25.0	5-B
501	3.49	8.6	30.0	5-B	332	3.49	8.6	30.0	5-B
481	3.64	6.9	25.0	5-3V	319	3.64	6.9	25.0	5-3V
476	3.68	6.8	25.0	5-B	315	3.68	6.8	25.0	5-B
464	3.77	7.5	28.0	3-5V	308	3.77	7.5	28.0	3-5V
462	3.79	6.6	25.0	5-B	306	3.79	6.6	25.0	5-B
452	3.87	6.5	25.0	5-3V	300	3.87	6.5	25.0	5-3V
432	4.05	7.4	30.0	5-B	286	4.05	7.4	30.0	5-B
397	4.41	6.8	30.0	5-B	263	4.41	6.8	30.0	5-B
385	4.55	6.6	30.0	5-B	255	4.55	6.6	30.0	5-B
359	4.88	6.9	33.5	5-3V	238	4.88	6.9	33.5	5-3V
347	5.05	7.5	37.5	3-5V	230	5.05	7.5	37.5	3-5V
340	5.14	7.4	38.0	5-B	226	5.14	7.4	38.0	5-B
337	5.19	6.5	33.5	5-3V	224	5.19	6.5	33.5	5-3V
313	5.59	6.8	38.0	5-B	208	5.59	6.8	38.0	5-B
304	5.76	6.6	38.0	5-B	201	5.76	6.6	38.0	5-B

* Stock FLEXIDYNE sheaves listed on page PT3-16 - PT3-17.

★ Outside diameter of 3V DYNA-V sheaves. Datum diameter of A and B sheaves. All ratios are based on P.D. for DYNA-V Sheaves and Datum diameter for A and B Sheaves.

* Stock TAPER-LOCK sheaves in V-drives section.

FEATURES/BENEFITS PAGE PT3-2	SPECIFICATION PAGE PT3-3	SELECTION PAGE PT3-4	ENGINEERING/TECHNICAL PAGE PT3-26
---------------------------------	-----------------------------	-------------------------	--------------------------------------



FLEXIDYNE

V-Belt Drives For 15D FLEXIDYNE Drives

These are typical drives for average service conditions

Driven by 1750 RPM Motors					Driven by 1750 RPM Motors				
Driven RPM	V-Belt Drive Ratio	Diameter ★		Quan. & Belt Size ◆	Driven RPM	V-Belt Drive Ratio	Diameter ★		Quan. & Belt Size ◆
		Driver *	Driven ▲				Driver *	Driven ▲	
1750	1.00	9.75	9.75	4-5V	1160	1.00	9.75	9.75	4-5V
1699	1.03	9.0	9.25	5-5V	1126	1.03	9.0	9.25	5-5V
1663	1.05	9.5	10.0	6-C	1102	1.05	9.5	10.0	6-C
1651	1.06	9.75	10.3	4-5V	1094	1.06	9.75	10.3	4-5V
1620	1.08	9.0	9.75	5-5V	1074	1.08	9.0	9.75	5-5V
1606	1.09	8.5	9.25	5-5V	1064	1.09	8.5	9.25	5-5V
1591	1.10	10.0	11.0	6-C	1055	1.10	10.0	11.0	6-C
1575	1.11	9.0	10.0	6-C	1044	1.11	9.0	10.0	6-C
1563	1.12	9.75	10.9	4-5V	1036	1.12	9.75	10.9	4-5V
1531	1.14	10.5	12.0	5-C	1015	1.14	10.5	12.0	5-C
1522	1.15	8.5	9.75	5-5V	1009	1.15	8.5	9.75	5-5V
1496	1.17	9.0	10.5	6-C	994	1.17	9.0	10.5	6-C
1458	1.20	10.0	12.0	6-C	966	1.20	10.0	12.0	6-C
1446	1.21	9.75	11.8	4-5V	959	1.21	9.75	11.8	4-5V
1432	1.22	9.0	11.0	6-C	949	1.22	9.0	11.0	6-C
1413	1.24	10.5	13.0	5-C	937	1.24	10.5	13.0	5-C
1385	1.26	9.5	12.0	6-C	918	1.26	9.5	12.0	6-C
1367	1.28	9.75	12.5	4-3V	906	1.28	9.75	12.5	4-3V
1357	1.29	8.5	10.9	5-5V	899	1.29	8.5	10.9	5-5V
1346	1.30	10.0	13.0	6-C	892	1.30	10.0	13.0	6-C
1336	1.31	9.0	11.8	5-5V	885	1.31	9.0	11.8	5-5V
1313	1.33	10.5	14.0	5-C	870	1.33	10.5	14.0	5-C
1287	1.36	9.75	13.2	4-5V	853	1.36	9.75	13.2	4-5V
1279	1.37	9.5	13.0	6-C	848	1.37	9.5	13.0	6-C
1259	1.39	8.5	11.8	5-5V	835	1.39	8.5	11.8	5-5V
1250	1.40	10.0	14.0	6-C	829	1.40	10.0	14.0	6-C
1215	1.44	9.75	14.0	4-5V	806	1.44	9.75	14.0	4-5V
1190	1.47	9.0	13.2	5-5V	789	1.47	9.0	13.2	5-5V
1182	1.48	8.5	12.5	5-5V	784	1.48	8.5	12.5	5-5V
1148	1.52	10.5	16.0	5-C	761	1.52	10.5	16.0	5-C
1136	1.54	9.75	15.0	4-5V	753	1.54	9.75	15.0	4-5V
1122	1.56	8.5	13.2	5-5V	744	1.56	8.5	13.2	5-5V
1094	1.60	10.0	16.0	6-C	725	1.60	10.0	16.0	6-C
1061	1.65	9.75	16.0	4-5V	703	1.65	9.75	16.0	4-5V
1048	1.67	9.0	15.0	5-5V	695	1.67	9.0	15.0	5-5V
1039	1.68	9.5	16.0	6-C	689	1.68	9.5	16.0	6-C
989	1.77	8.5	15.0	5-5V	655	1.77	8.5	15.0	5-5V
978	1.79	9.0	16.0	5-5V	648	1.79	9.0	16.0	5-5V
926	1.89	8.5	16.0	5-5V	614	1.89	8.5	16.0	5-5V
919	1.91	10.5	20.0	5-C	609	1.91	10.5	20.0	5-C
875	2.00	10.0	20.0	6-C	580	2.00	10.0	20.0	6-C
831	2.10	9.5	20.0	6-C	551	2.10	9.5	20.0	6-C
799	2.19	9.75	21.2	4-5V	530	2.19	9.75	21.2	4-5V
788	2.22	9.0	20.0	6-C	522	2.22	9.0	20.0	6-C
766	2.28	10.5	24.0	5-C	508	2.28	10.5	24.0	5-C
738	2.37	9.0	21.2	5-5V	489	2.37	9.0	21.2	5-5V
729	2.40	10.0	24.0	6-C	483	2.40	10.0	24.0	6-C
697	2.51	8.5	21.2	5-5V	462	2.51	8.5	21.2	5-5V
656	2.67	9.0	24.0	6-C	435	2.67	9.0	24.0	6-C
612	2.86	10.5	30.0	5-C	406	2.86	10.5	30.0	5-C
606	2.89	9.75	28.0	4-5V	401	2.89	9.75	28.0	4-5V
583	3.00	10.0	30.0	6-C	386	3.00	10.0	30.0	6-C
559	3.13	9.0	28.0	5-5V	371	3.13	9.0	28.0	5-5V
527	3.32	8.5	28.0	5-5V	349	3.32	8.5	28.0	5-5V
510	3.43	10.5	36.0	5-C	338	3.43	10.5	36.0	5-C
486	3.60	10.0	36.0	6-C	322	3.60	10.0	36.0	6-C
462	3.79	9.5	36.0	6-C	306	3.79	9.5	36.0	6-C
451	3.88	9.75	37.5	4-5V	299	3.88	9.75	37.5	4-5V
438	4.00	9.0	36.0	6-C	290	4.00	9.0	36.0	6-C
417	4.20	9.0	37.5	5-5V	276	4.20	9.0	37.5	5-5V
393	4.45	8.5	37.5	5-5V	261	4.45	8.5	37.5	5-5V
378	4.64	9.5	44.0	6-C	251	4.64	9.5	44.0	6-C
368	4.76	10.5	50.0	5-C	244	4.76	10.5	50.0	5-C
358	4.89	9.0	44.0	6-C	237	4.89	9.0	44.0	6-C
350	5.00	10.0	50.0	6-C	232	5.00	10.0	50.0	6-C
338	5.17	9.75	50.0	4-5V	224	5.17	9.75	50.0	4-5V
312	5.61	9.0	50.0	5-5V	207	5.61	9.0	50.0	5-5V
295	5.94	8.5	50.0	5-5V	195	5.94	8.5	50.0	5-5V

* Stock FLEXIDYNE sheaves listed on page PT3-16 - PT3-17.

* Stock TAPER-LOCK sheaves in V-drives section.

★ Outside diameter of 3V DYNA-V sheaves. Datum diameter of A and B sheaves. All ratios are based on P.D. for DYNA-V Sheaves and Datum diameter for A and B Sheaves.

FEATURES/BENEFITS PAGE PT3-2	SPECIFICATION PAGE PT3-3	SELECTION PAGE PT3-4	ENGINEERING/TECHNICAL PAGE PT3-26
---------------------------------	-----------------------------	-------------------------	--------------------------------------



ENGINEERING/TECHNICAL

FLEXIDYNE

SCF FLEXIDYNE Mechanism Used In A C-Flex Module

Maximum Allowable Acceleration Time (seconds)

Frequency of Starts	RPM	Starting Horsepower*						
		0.50	1.00	1.50	2.00	2.50	3.00	3.60
2 Hours	1750	140	90	70	56	50	44	37
1 Hour	1750	140	90	70	56	50	44	37
30 Min.	1750	140	90	70	56	50	44	37
15 Min.	1750	140	90	70	56	50	44	37
10 Min.	1750	125	80	60	48	42	39	32
5 Min.	1750	74	46	46	29	26	23	20
2 Min.	1750	30	19	15	12	10	8	5
1 Min.	1750	15	10	5	3

Table may be interpolated for HP and cycle times between those figures listed.

Thermal Capacities

FLEXIDYNE Mechanism Size 5

Maximum Allowable Acceleration Time (seconds)

Frequency of Starts	RPM	Starting Horsepower*					
		0.30	0.50	0.70	0.90	1.10	1.30
2 Hours	1750	330	220	170	128	116	104
	1160
	870
1 Hour	1750	330	220	170	128	116	104
	1160
	870
30 Min.	1750	330	220	170	128	116	104
	1160
	870
15 Min.	1750	330	220	170	128	116	104
	1160
	870
10 Min.	1750	300	200	150	116	105	94
	1160
	870
5 Min.	1750	170	116	88	68	62	55
	1160
	870
2 Min.	1750	70	47	35	27	25	22
	1160
	870
1 Min.	1750	35	23	18	14	12	11
	1160
	870

Table may be interpolated for HP and cycle times between those figures listed.

* Starting HP is dependent on the amount of flow charge used.

FEATURES/BENEFITS PAGE PT3-2	SPECIFICATION PAGE PT3-3	SELECTION PAGE PT3-4	SELECTION/DIMENSIONS PAGE PT3-8
---------------------------------	-----------------------------	-------------------------	------------------------------------



FLEXIDYNE

FLEXIDYNE Mechanism Size 55

Maximum Allowable Acceleration Time (seconds)

Frequency of Starts	RPM	Starting Horsepower*								
		0.50	0.75	1.00	1.50	2.00	2.50	3.00	3.50	4.00
2 Hours	1750	125	92	76	67	60	55	50
	1160	250	175	148	110
	870
1 Hour	1750	125	92	76	67	60	55	50
	1160	250	175	148	110
	870
30 Min.	1750	125	92	76	67	60	55	50
	1160	250	175	148	110
	870
15 Min.	1750	125	92	76	67	60	55	50
	1160	250	175	148	110
	870
10 Min.	1750	96	67	60	52	47	43	40
	1160	190	130	110	82
	870
5 Min.	1750	58	41	37	32	29	25	20
	1160	110	80	68	50
	870
2 Min.	1750	30	23	20	17	15	13	10
	1160	60	40	35	28
	870
1 Min.	1750	19	15	13	11	9	8	6
	1160	33	26	22	18
	870

FLEXIDYNE Mechanism Size 70

Maximum Allowable Acceleration Time (seconds)

Frequency of Starts	RPM	Starting Horsepower*									
		0.50	0.75	1.00	2.00	2.50	3.00	4.00	6.00	8.00	10.00
2 Hours	1750	210	180	150	110	80	63	53
	1160	500	260	190	170	130
	870	900	800	550
1 Hour	1750	210	180	150	110	80	63	53
	1160	500	260	190	170	130
	870	900	800	550
30 Min.	1750	210	180	150	110	80	63	53
	1160	500	260	190	170	130
	870	900	800	550
15 Min.	1750	190	160	140	100	72	56	46
	1160	450	230	165	155	118
	870	800	700	500
10 Min.	1750	170	140	120	83	60	41	36
	1160	320	190	143	133	90
	870	500	400	330
5 Min.	1750	105	85	74	54	38	29	23
	1160	200	120	88	80	60
	870	250	230	210
2 Min.	1750	58	45	39	30	21	16	13
	1160	80	60	49	45	36
	870	100	100	100
1 Min.	1750	36	29	25	19	13	10	8
	1160	45	38	33	28	23
	870	50	50	50

Table may be interpolated for HP and cycle times between those figures listed.

* Starting HP is dependent on the amount of flow charge used

FEATURES/BENEFITS PAGE PT3-2	SPECIFICATION PAGE PT3-3	SELECTION PAGE PT3-4	SELECTION/DIMENSIONS PAGE PT3-8
---------------------------------	-----------------------------	-------------------------	------------------------------------



ENGINEERING/TECHNICAL

FLEXIDYNE

FLEXIDYNE Mechanism Size 75

Maximum Allowable Acceleration Time (seconds)

Frequency of Starts	RPM	Starting Horsepower*									
		1.00	2.00	3.00	4.00	5.00	7.00	8.00	10.00	15.00	20.00
2 Hours	1750	85	73	70	58	48	40
	1160	250	150	110	90	75	
	870	520	300	200	
1 Hour	1750	85	73	70	58	48	40
	1160	250	150	110	90	75	
	870	520	300	200	
30 Min.	1750	85	73	70	58	48	40
	1160	250	150	110	90	75	
	870	520	300	200	
15 Min.	1750	80	68	64	53	43	35
	1160	220	130	100	85	70	
	870	520	300	200	
10 Min.	1750	65	57	54	45	34	27
	1160	180	110	82	70	60	
	870	420	210	150	
5 Min.	1750	40	37	35	30	21	17
	1160	110	65	50	45	38	
	870	260	130	100	
2 Min.	1750	22	20	18	16	11	8
	1160	60	40	28	24	21	
	870	100	80	52	
1 Min.	1750	15	13	11	10	8	5
	1160	40	22	18	16	14	
	870	50	40	30	

FLEXIDYNE MECHANISM SIZE 9

Maximum Allowable Acceleration Time (seconds)

Frequency of Starts	RPM	Starting Horsepower*									
		2.50	5	10.00	15.00	17.50	20.00	25.00	30.00	35.00	38.00
2 Hours	1750	135	76	64	52	40	26	21	16
	1160	230	150	120	110	
	870	1000	310	
1 Hour	1750	135	76	64	52	40	26	21	16
	1160	230	150	120	110	
	870	1000	310	
30 Min.	1750	135	76	64	52	40	26	21	16
	1160	230	150	120	110	
	870	820	260	
15 Min.	1750	118	66	55	45	35	22	18	15
	1160	190	120	100	92	
	870	600	180	
10 Min.	1750	100	58	48	38	30	18	15	13
	1160	160	100	85	78	
	870	425	140	
5 Min.	1750	70	38	31	25	20	12	10	9
	1160	100	65	50	47	
	870	225	70	
2 Min.	1750	28	15	12	10	8	5	4	3
	1160	42	26	21	19	
	870	90	27	
1 Min.	1750	14	7	6	5	4
	1160	22	13	11	9	
	870	45	13	

Table may be interpolated for HP and cycle times between those figures listed.

* Starting HP is dependent on the amount of flow charge used



FLEXIDYNE

FLEXIDYNE Mechanism Size 11

Maximum Allowable Acceleration Time (seconds)

Frequency of Starts	RPM	Starting Horsepower*										
		5	10	20	30	40	50	60	70	80	90	100
2 Hours	1750	116	80	44	34	24	21	18	16	14
	1160	480	308	136	107	78
	870	1000	600	320
1 Hour	1750	116	80	44	34	24	21	18	16	14
	1160	480	308	136	107	78
	870	950	560	300
30 Min.	1750	116	80	44	34	24	21	18	16	14
	1160	400	257	115	89	64
	870	700	440	230
15 Min.	1750	96	67	37	28	20	17	15	13	12
	1160	270	175	80	63	46
	870	450	280	150
10 Min.	1750	80	56	32	24	17	14	12	11	10
	1160	200	130	60	47	35
	870	290	180	90
5 Min.	1750	50	35	20	15	10	9	8	7	6
	1160	100	65	30	23	17
	870	130	80	42
2 Min.	1750	21	14	8	6	4	3
	1160	40	26	12	9	6
	870	46	30	15
1 Min.	1750	11	7	4	3
	1160	20	13	6	4	3
	870	21	13	6

Table may be interpolated for HP and cycle times between those figures listed.

* Starting HP is dependent on the amount of flow charge used

FEATURES/BENEFITS PAGE PT3-2	SPECIFICATION PAGE PT3-3	SELECTION PAGE PT3-4	SELECTION/DIMENSIONS PAGE PT3-8
---------------------------------	-----------------------------	-------------------------	------------------------------------



ENGINEERING/TECHNICAL

FLEXIDYNE

FLEXIDYNE Mechanism Size 15

Maximum Allowable Acceleration Time (seconds)

Frequency of Starts	RPM	Starting Horsepower*									
		10	20	30	40	50	60	70	80	90	100
2 Hours	1750	35	31	27	23	20	16
	1160	...	230	167	105	81	56	47	39	33	28
	870	560	300	200	145
1 Hour	1750	35	31	27	23	20	16
	1160	...	230	167	105	81	56	47	39	33	28
	870	560	300	200	145
30 Min.	1750	34	30	26	22	18	15
	1160	...	230	167	105	81	56	47	39	33	28
	870	460	240	160	120
15 Min.	1750	30	27	23	20	16	13
	1160	...	190	140	90	68	47	40	33	28	24
	870	350	170	125	90
10 Min.	1750	28	25	21	17	15	13
	1160	...	160	117	74	57	40	34	28	24	20
	870	260	130	95	68
5 Min.	1750	19	16	14	12	10	9
	1160	...	100	73	46	35	25	21	17	14	12
	870	160	80	60	42
2 Min.	1750	12	10	9	7	6	5
	1160	...	44	32	20	15	11	9	7	6	5
	870	85	42	32	22
1 Min.	1750	8	7	6	5	4	3
	1160	...	23	17	10	7	5	5	4	3	3
	870	53	25	19	14

Frequency of Starts	RPM	Starting Horsepower*									
		110	120	130	140	150	160	170	180	190	200
2 Hours	1750	15	14	13	12	11	10	9	9	8	8
	1160
	870
1 Hour	1750	15	14	13	12	11	10	9	9	8	8
	1160
	870
30 Min.	1750	14	13	12	11	10	10	9	9	8	7
	1160
	870
15 Min.	1750	12	11	10	10	9	8	8	7	7	6
	1160
	870
10 Min.	1750	12	11	10	9	8	8	7	7	6	6
	1160
	870
5 Min.	1750	8	7	7	6	6	6	5	5	4	4
	1160
	870
2 Min.	1750	5	4	4	3	3
	1160
	870
1 Min.	1750	3
	1160
	870

Table may be interpolated for HP and cycle times between those figures listed

* Starting HP is dependent on the amount of flow charge used.

Thermal capacities are shown for single cavity units. For duplex cavities, starting horsepower = (HP * Starting Torque%)/2

Caution: At these capacities, the housing temperature may reach 250 degrees F.

FEATURES/BENEFITS PAGE PT3-2	SPECIFICATION PAGE PT3-3	SELECTION PAGE PT3-4	SELECTION/DIMENSIONS PAGE PT3-8
---------------------------------	-----------------------------	-------------------------	------------------------------------



FLEXIDYNE

FLEXIDYNE Mechanism Size 18 Maximum Allowable Acceleration Time (seconds)

Frequency of Starts	RPM	Starting Horsepower*							
		20	40	60	80	100	120	140	160
2 Hours	1160	60	49	38	33
	870	200	160	120	96	72	62	52
	720	600	370	220	160
1 Hour	1160	60	49	38	33
	870	200	160	120	96	72	62	52
	720	560	350	200	150
30 Min.	1160	56	45	35	30
	870	160	130	100	80	60	52	44
	720	450	280	160	120
15 Min.	1160	44	35	26	23
	870	115	94	72	58	45	38	32
	720	300	180	100	74
10 Min.	1160	32	26	20	17
	870	90	72	54	43	32	27	22
	720	200	120	66	48
5 Min.	1160	17	13	10	9
	870	44	35	27	21	16	13	11
	720	90	54	32	23
2 Min.	1160	7	5	4	4
	870	17	13	10	8	6	5	4
	720	35	21	12	8
1 Min.	1160
	870	8	6	5	4	3
	720	16	10	5	4

Frequency of Starts	RPM	Starting Horsepower*						
		180	200	220	240	260	280	300
2 Hours	1160	28	25	22	20	18	16	14
	870
	720
1 Hour	1160	28	25	22	20	18	16	14
	870
	720
30 Min.	1160	26	23	20	18	17	15	13
	870
	720
15 Min.	1160	20	18	16	14	13	11	10
	870
	720
10 Min.	1160	15	13	12	10	9	8	7
	870
	720
5 Min.	1160	8	7	6	5	5	4	4
	870
	720
2 Min.	1160
	870
	720
1 Min.	1160
	870
	720

Table may be interpolated for HP and cycle times between those figures listed.

* Starting HP is dependent on the amount of flow charge used.

Thermal capacities are shown for single cavity units.

For duplex cavities, starting horsepower = (HP * Starting Torque%)/2

Caution: At these capacities, the housing temperature may reach 250 degrees F.

FEATURES/BENEFITS PAGE PT3-2	SPECIFICATION PAGE PT3-3	SELECTION PAGE PT3-4	SELECTION/DIMENSIONS PAGE PT3-8
---------------------------------	-----------------------------	-------------------------	------------------------------------

NOTES

PT Component
Reference Guide

Couplings

Clutches and Brakes

FLEXIDYNE

Fluid Couplings

TORQUE-TAMER

Bushings