

QUANTIS - ILH

Mounting Options	ILH-2
Nomenclature	ILH-4
Mounting Positions and Oil Quantities	ILH-7
Overhung Loads.	ILH-11
Selection - Reducer - 60 Hz	
ILH 38	ILH-13
ILH 48	ILH-20
ILH 68	ILH-28
ILH 88	ILH-37
ILH 108	ILH-45
ILH 128	ILH-51
ILH 148	ILH-57
ILH 168	ILH-62
Stock/Non-Stock Part Numbers	ILH-67
Selection - Integral Gearmotor - 60 HZ	ILH-78
Dimension	
ILH 38	ILH-118
ILH 48	ILH-158
ILH 68	ILH-198
ILH 88	ILH-238
ILH 108	ILH-270
ILH 128	ILH-286
ILH 148	ILH-302
ILH 168	ILH-318
Slide Base	ILH-334
Thermal Ratings	ILH-335
Weights	ILH-343
Part Number Index	Index-1

MOUNTING OPTIONS



QUANTIS

QUANTIS GOLD

ILH

RHB

MSM

ILH MOUNTING OPTIONS

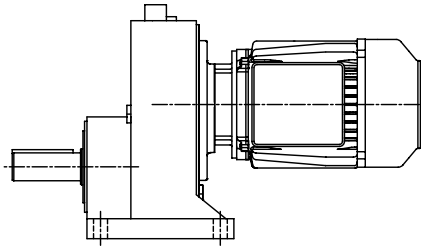
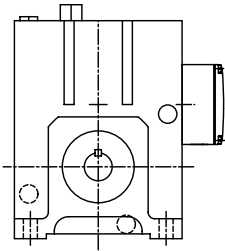

HB..1../.S..
In-Line Helical
Foot Mounted
Single Reduction
Solid Shaft

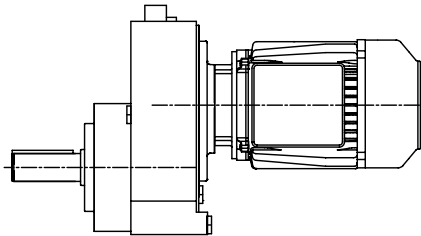
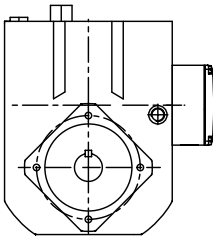

HF..1../.S..B14
In-Line Helical
B14 Flange Mounted
Single Reduction
Solid Shaft

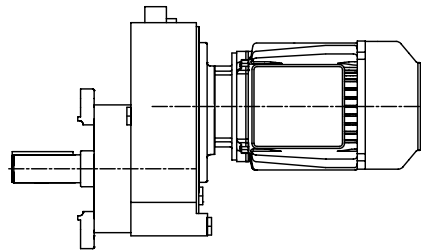
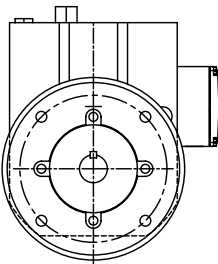

HF..1../.S..B5
In-Line Helical
B5 Flange Mounted
Single Reduction
Solid Shaft

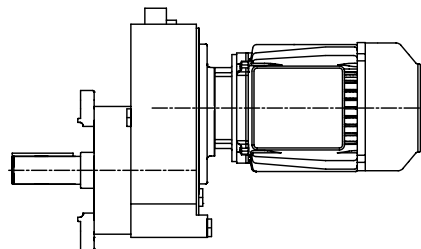
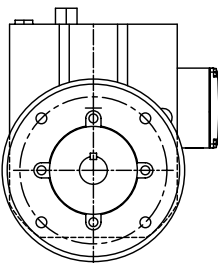

HF..1../.S..NEMA
In-Line Helical
NEMA Output Flange Mounted
Single Reduction
Solid Shaft

MOUNTING POSITIONS
PAGE ILH-6

SELECTION GEARMOTOR
PAGE ILH-74

DIMENSIONS
PAGE ILH-114

THERMAL RATINGS
PAGE ILH-331

MOUNTING OPTIONS



ILH MOUNTING OPTIONS

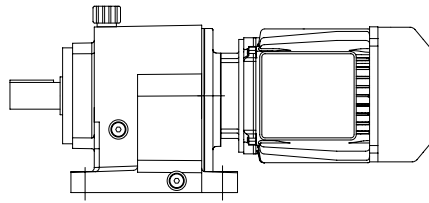
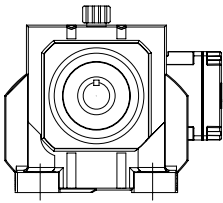

HB . . 2/3 . . / . . S . .
In-Line Helical
Foot Mounted
Double/Triple Reduction
Solid Shaft

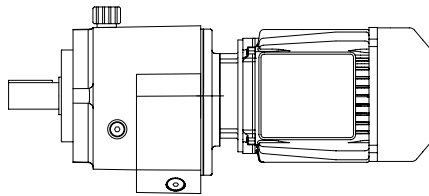
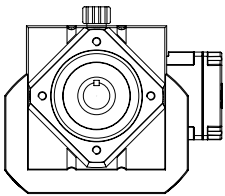

HF . . 2/3 . . / . . S . . B14
In-Line Helical
B14 Flange Mounted
Double/Triple Reduction
Solid Shaft

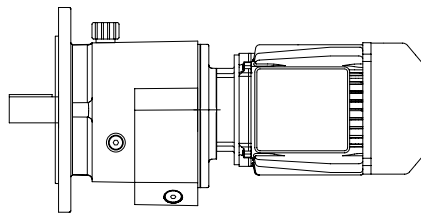
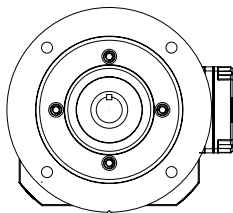

HF . . 2/3 . . / . . S . . B5
In-Line Helical
B5 Flange Mounted
Double/Triple Reduction
Solid Shaft

QUANTIS

QUANTIS GOLD

ILH

RHB

MSM

MOUNTING POSITIONS PAGE ILH-6	SELECTION GEARMOTOR PAGE ILH-74	DIMENSIONS PAGE ILH-114	THERMAL RATINGS PAGE ILH-331
----------------------------------	------------------------------------	----------------------------	---------------------------------

IN-LINE HELICAL C-FACE REDUCERS (ILH)

Ex:

1	2	3	4	5	6	7
H	B	88	2	C	N	180TC

 /

8	9	10	10a	10b	11	11a
20.81	A1	S	I	2.125	-	-

1. PRODUCT TYPE

H = ILH

2. OUTPUT CONFIGURATION

B = Foot Mounted

F = Flange Mounted

3. UNIT SIZE

38 48 68 88
108 128 148 168

4. STAGE OF REDUCTION

1 = Single Reduction

2 = Double Reduction

3 = Triple Reduction

5. INPUT CONFIGURATION

C = Clamp Collar

L = 3 Pc Coupling

6. MOTOR TYPE

N = Nema

I = IEC

7. MOTOR FRAME

Nema

56C 140TC 180TC 210TC
250TC 280TC 320TC 360TC

IEC

71D 80D 90D 100D 112D 132D
160D 180D 200D 225D 250D

8. RATIO (Use actual ratio from Selection pages)

ILH 38	1.59	-	191.75
ILH 48	1.52	-	208.77
ILH 68	1.41	-	281.01
ILH 88	1.71	-	300.41
ILH 108	5.51	-	359.30
ILH 128	3.63	-	268.16
ILH 148	4.92	-	336.11
ILH 168	4.93	-	341.61

9. MOUNTING POSITIONS (See page ILH-7)

A1 A2 A3
A4 A5 A6

10. OUTPUT SHAFT TYPE

S = Single Extension Solid Shaft

10a. OUTPUT SHAFT DIMENSION

I = Inch

M = Metric

10b. OUTPUT SHAFT DIAMETER - Double/Triple Reduction

	Std	Optional		
ILH 38	1.000	1.250	25mm	30mm
ILH 48	1.250	1.625	30mm	40mm
ILH 68	1.625	2.125	40mm	50mm

10b. OUTPUT SHAFT DIAMETER - Double/Triple Reduction (continued)

	Std	Optional		
ILH 88	2.125	2.375	50mm	60mm
ILH 108	2.375	2.875	60mm	70mm
ILH 128	2.875	3.625	70mm	90mm
ILH 148	3.625	4.000	90mm	100mm
ILH 168	4.000	4.750	100mm	120mm

OUTPUT SHAFT DIAMETER - Single Reduction

	Std	Optional
ILH 38	0.875	20mm
ILH 48	1.125	25mm
ILH 68	1.375	30mm
ILH 88	1.625	40mm

11. OUTPUT FLANGE TYPE (HF Style Housing)

B5
B14 (Std)
NEMA (Single Reduction)

11a. OUTPUT FLANGE DIAMETER - Double/Triple Reduction

	Std	Optional
	B14 Flange	B5 Flange
ILH 38	120mm	160mm
		200mm
ILH 48	160mm	200mm
		250mm
ILH 68	190mm	250mm
		300mm
ILH 88	245mm	300mm
		350mm
ILH 108	300mm	350mm
		450mm
ILH 128	340mm	350mm
		450mm
ILH 148	340mm	450mm
		550mm
ILH 168	400mm	450mm
		550mm

OUTPUT FLANGE DIAMETER - Single Reduction

	Std	Optional	
	B14 Flange	B5 Flange	NEMA Flange
ILH 38	120mm	160mm	140TC
		200mm	
ILH 48	120mm	160mm	180TC
		200mm	
ILH 68	160mm	200mm	210TC
		250mm	
ILH 88	190mm	250mm	-
		300mm	

MOUNTING POSITIONS PAGE ILH-7	SELECTION REDUCER PAGE ILH-14	DIMENSIONS PAGE ILH-118	THERMAL RATINGS PAGE ILH-335
----------------------------------	----------------------------------	----------------------------	---------------------------------

IN-LINE HELICAL SEPARATE REDUCERS (ILH)

Ex:

1	2	3	4	5	6	7
H	F	38	2	S	I	71

 /

8	9	10	10a	10b	11	11a
4.77	A1	S	I	1.000	B5	160MM

1. PRODUCT TYPE

H = ILH

2. OUTPUT CONFIGURATION

B = Foot Mounted

F = Flange Mounted

3. UNIT SIZE

38 48 68 88
108 128 148 168

4. STAGE OF REDUCTION

1 = Single Reduction

2 = Double Reduction

3 = Triple Reduction

5. INPUT CONFIGURATION

S = Separate

6. INPUT SHAFT DIMENSION

I = Inch

M = Metric

7. SEPARATE GROUP

71 80 90 100 112
132 160 180 225 250

8. RATIO (Use actual ratio from Selection pages)

ILH 38	1.59	-	191.75
ILH 48	1.52	-	208.77
ILH 68	1.41	-	281.01
ILH 88	1.71	-	300.41
ILH 108	5.51	-	359.30
ILH 128	3.63	-	268.16
ILH 148	4.92	-	336.11
ILH 168	4.93	-	341.61

9. MOUNTING POSITIONS (See page ILH-7)

A1	A2	A3
A4	A5	A6

10. OUTPUT SHAFT TYPE

S = Single Extension Solid Shaft

10a. OUTPUT SHAFT DIMENSION

I = Inch

M = Metric

10b. OUTPUT SHAFT DIAMETER - Double/Triple Reduction

	Std	Optional		
ILH 38	1.000	1.250	25mm	30mm
ILH 48	1.250	1.625	30mm	40mm
ILH 68	1.625	2.125	40mm	50mm
ILH 88	2.125	2.375	50mm	60mm
ILH 108	2.375	2.875	60mm	70mm
ILH 128	2.875	3.625	70mm	90mm
ILH 148	3.625	4.000	90mm	100mm
ILH 168	4.000	4.750	100mm	120mm

OUTPUT SHAFT DIAMETER - Single Reduction

	Std	Optional
ILH 38	0.875	20mm
ILH 48	1.125	25mm
ILH 68	1.375	30mm
ILH 88	1.625	40mm

11. OUTPUT FLANGE TYPE (HF Style Housing)

B5
B14 (Std)
NEMA (Single Reduction)

11a. OUTPUT FLANGE DIAMETER - Double/Triple Reduction

	Std	Optional	
	B14 Flange	B5 Flange	NEMA Flange
ILH 38	120mm	160mm	140TC
ILH 48	160mm	200mm	180TC
ILH 68	190mm	250mm	210TC
ILH 88	245mm	300mm	-
ILH 108	300mm	350mm	-
ILH 128	340mm	450mm	-
ILH 148	340mm	550mm	-
ILH 168	400mm	550mm	-

OUTPUT FLANGE DIAMETER - Single Reduction

	Std	Optional	
	B14 Flange	B5 Flange	NEMA Flange
ILH 38	120mm	160mm	140TC
ILH 48	120mm	200mm	180TC
ILH 68	160mm	200mm	210TC
ILH 88	190mm	250mm	-
		300mm	-

MOUNTING POSITIONS PAGE ILH-7	SELECTION REDUCER PAGE ILH-14	DIMENSIONS PAGE ILH-118	THERMAL RATINGS PAGE ILH-335
----------------------------------	----------------------------------	----------------------------	---------------------------------

IN-LINE HELICAL INTEGRAL GEARMOTORS (ILH)

Ex:	1	2	3	4	5	6	7	/	8	9	10	10a	10b	11	11a	12
	H	B	48	2	G	H	71E4	/	31.77	A4	S	I	1.250	-	-	-

1. PRODUCT TYPE

H = ILH

2. OUTPUT CONFIGURATION

B = Foot Mounted

F = Flange Mounted

3. UNIT SIZE

38 48 68 88
108 128 148 168

4. STAGE OF REDUCTION

1 = Single Reduction

2 = Double Reduction

3 = Triple Reduction

5. INPUT CONFIGURATION

G = Integral Gearmotor

6. MOTOR TYPE

H = Horsepower

7. MOTOR FRAME

71C4	.25 Hp	90I4	2 Hp
71D4	.33 Hp	100J4	3 Hp
71E4	.50 Hp	112L4	5 Hp
80F4	.75 Hp	132M4	7.5 Hp
80G4	1 Hp	132N4	10 Hp
90H4	1.5 Hp		

8. RATIO (Use actual ratio from Selection pages)

ILH 38	1.59	- 191.75
ILH 48	1.52	- 208.77
ILH 68	1.41	- 281.01
ILH 88	1.71	- 300.41
ILH 108	5.51	- 359.30
ILH 128	3.63	- 268.16
ILH 148	4.92	- 336.11
ILH 168	4.93	- 341.61

9. MOUNTING POSITIONS (See page ILH- 7)

A1 A2 A3
A4 A5 A6

10. OUTPUT SHAFT TYPE

S = Single Extension Solid Shaft

10a. OUTPUT SHAFT DIMENSION

I = Inch
M = Metric

10b. OUTPUT SHAFT DIAMETER - Double/Triple Reduction

	Std		Optional	
ILH 38	1.000	1.250	25mm	30mm
ILH 48	1.250	1.625	30mm	40mm
ILH 68	1.625	2.125	40mm	50mm
ILH 88	2.125	2.375	50mm	60mm
ILH 108	2.375	2.875	60mm	70mm

10b. OUTPUT SHAFT DIAMETER - Double/Triple Reduction (continued)

	Std		Optional	
ILH 128	2.875	3.625	70mm	90mm
ILH 148	3.625	4.000	90mm	100mm
ILH 168	4.000	4.750	100mm	120mm

OUTPUT SHAFT DIAMETER - Single Reduction

	Std	Optional
ILH 38	0.875	20mm
ILH 48	1.125	25mm
ILH 68	1.375	30mm
ILH88	1.625	40mm

11. OUTPUT FLANGE TYPE (HF Style Housing)

B5
B14 (Std)
NEMA (Single Reduction)

11a. OUTPUT FLANGE DIAMETER - Double/Triple Reduction

	Std	Optional	
	B14 Flange	B5 Flange	NEMA
ILH 38	120mm	160mm	140TC
		200mm	
ILH 48	160mm	200mm	180TC
		250mm	
ILH 68	190mm	250mm	210TC
		300mm	
ILH 88	245mm	300mm	-
		350mm	
ILH 108	300mm	350mm	
		450mm	
ILH 128	340mm	350mm	
		450mm	
ILH 148	340mm	450mm	
		550mm	
ILH 168	400mm	450mm	
		550mm	

OUTPUT FLANGE DIAMETER - Single Reduction

	Std	Optional	
	B14 Flange	B5 Flange	NEMA
ILH 38	120mm	160mm	140TC
		200mm	
ILH 48	120mm	160mm	180TC
		200mm	
ILH 68	160mm	200mm	210TC
		250mm	
ILH 88	190mm	250mm	-
		300mm	

MOUNTING POSITIONS PAGE ILH-7	SELECTION GEARMOTOR PAGE ILH-78	DIMENSIONS PAGE ILH-118	THERMAL RATINGS PAGE ILH-335
----------------------------------	------------------------------------	----------------------------	---------------------------------

MOUNTING POSITIONS



QUANTIS

QUANTIS GOLD

ILH

RHB

MSM

IN LINE HELICAL C-FACE REDUCERS & INTEGRAL GEARMOTORS

These mounting arrangements are for all output configurations and output shaft types. **IMPORTANT!** When ordering, please specify mounting position for correct oil quantity. In cases of mounting position other than shown here with regard to the oil quantity, please reference the Incline Mounting page, QUANTIS-23, and contact Application Engineering.

NOTE: The oil volumes shown are approximate values and cannot be used to correctly set the reducer oil level - **ALWAYS** fill the reducer to the correct oil level plug and recheck in 1 week.

A1

Unit Size	Reduction Stage	Pints	Liters
38	1	0.3	0.2
	2	1.1	0.5
	3	1.1	0.5
48	1	0.5	0.3
	2	2.3	1.1
	3	2.3	1.1
68	1	1.1	0.5
	2	3.8	1.8
	3	3.6	1.7
88	1	1.6	0.8
	2	8.7	4.1
	3	8.5	4.0
108	2	14.2	6.7
	3	13.7	6.5
128	2	19.0	9.0
	3	18.4	8.7
148	2	25.8	12.2
	3	24.7	11.7
168	2	39.7	18.8
	3	38.3	18.1



Oil level



Ventilation



Oil drain

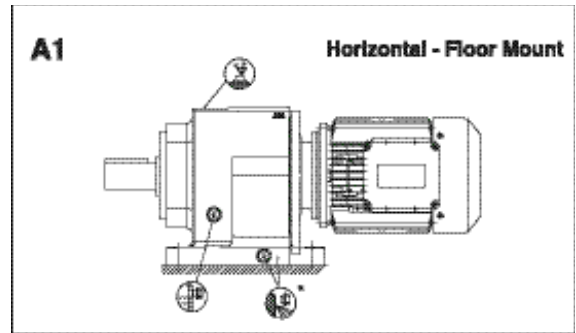

A2

Unit Size	Reduction Stage	Pints	Liters
38	1	1.2	0.6
	2	2.5	1.2
	3	2.3	1.1
48	1	2.2	1.1
	2	5.1	2.4
	3	5.1	2.4
68	1	3.9	1.9
	2	8.7	4.1
	3	8.5	4.0
88	1	8.0	3.8
	2	18.6	8.8
	3	18.8	8.9
108	2	29.6	14.0
	3	30.0	14.2
128	2	44.2	20.9
	3	45.8	21.5
148	2	58.5	27.7
	3	59.6	28.2
168	2	88.1	41.7
	3	92.4	43.7

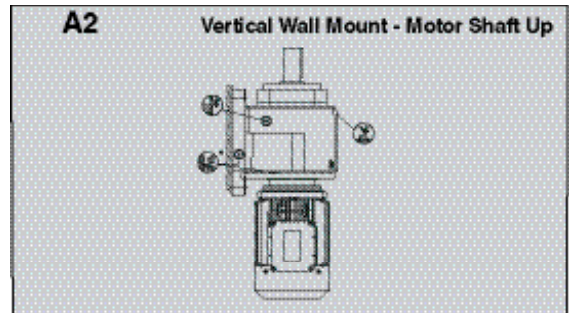

ILH 38 units are sealed for life and furnished with only one plug for filling and draining.

NOTE: Shaded A2 mounting is not a recommended mounting position due to the weight of oil on the high speed input seal.

NOMENCLATURE PAGE ILH-4	OVERHUNG LOADS PAGE ILH-11	SELECTION GEARMOTOR PAGE ILH-78	WEIGHTS PAGE ILH-343
----------------------------	-------------------------------	------------------------------------	-------------------------

MOUNTING POSITIONS



IN LINE HELICAL C-FACE REDUCERS & INTEGRAL GEARMOTORS

These mounting arrangements are for all output configurations and output shaft types. **IMPORTANT! When ordering, please specify mounting position for correct oil quantity.** In cases of mounting position other than shown here with regard to the oil quantity, please reference the Incline Mounting page, QUANTIS-23, and contact Application Engineering.

NOTE: The oil volumes shown are approximate values and cannot be used to correctly set the reducer oil level - **ALWAYS** fill the reducer to the correct oil level plug and recheck in 1 week.

A3

Unit Size	Reduction Stage	Pints	Liters
38	1	0.8	0.4
	2	1.3	0.6
	3	1.3	0.6
48	1	1.5	0.7
	2	3.2	1.5
	3	3.2	1.5
68	1	3.1	1.5
	2	5.3	2.5
	3	5.5	2.6
88	1	5.3	2.5
	2	12.0	5.7
	3	12.5	5.9
108	2	18.2	8.6
	3	19.0	9.0
128	2	27.9	13.2
	3	29.8	14.1
148	2	50.5	23.9
	3	49.5	23.4
168	2	67.8	32.1
	3	71.4	33.8



Oil level



Ventilation



Oil drain

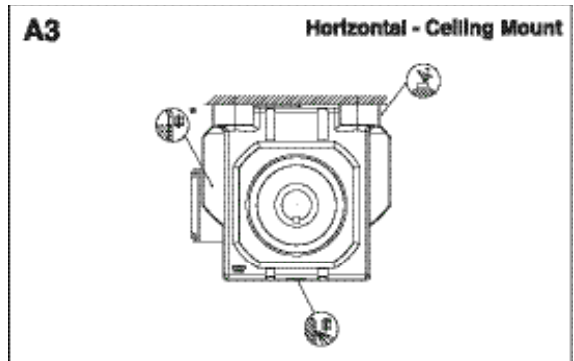

A4

Unit Size	Reduction Stage	Pints	Liters
38	1	1.0	0.5
	2	1.5	0.7
	3	1.9	0.9
48	1	1.5	0.7
	2	3.8	1.8
	3	4.9	2.3
68	1	3.7	1.8
	2	6.8	3.2
	3	8.5	4.0
88	1	4.9	2.3
	2	15.9	7.5
	3	19.7	9.3
108	2	27.9	13.2
	3	33.0	15.6
128	2	42.1	19.9
	3	51.6	24.4
148	2	54.3	25.7
	3	68.1	32.2
168	2	96.6	45.7
	3	115.0	54.4

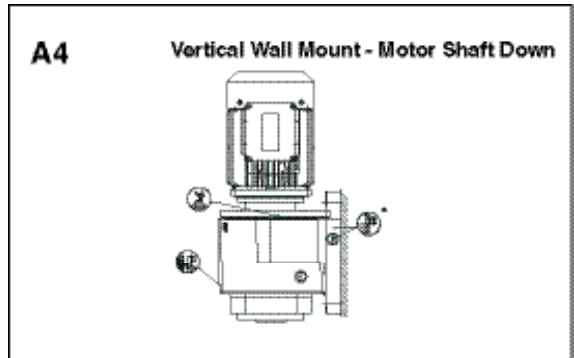

ILH 38 units are sealed for life and furnished with only one plug for filling and draining.

NOMENCLATURE PAGE ILH-4	OVERHUNG LOADS PAGE ILH-11	SELECTION GEARMOTOR PAGE ILH-78	WEIGHTS PAGE ILH-343
----------------------------	-------------------------------	------------------------------------	-------------------------

MOUNTING POSITIONS



IN LINE HELICAL C-FACE REDUCERS & INTEGRAL GEARMOTORS

These mounting arrangements are for all output configurations and output shaft types. **IMPORTANT! When ordering, please specify mounting position for correct oil quantity.** In cases of mounting position other than shown here with regard to the oil quantity, please reference the Incline Mounting page, QUANTIS-23, and contact Application Engineering.

NOTE: The oil volumes shown are approximate values and cannot be used to correctly set the reducer oil level - **ALWAYS** fill the reducer to the correct oil level plug and recheck in 1 week.

A5

Unit Size	Reduction Stage	Pints	Liters
38	1	0.5	0.3
	2	1.3	0.6
	3	1.3	0.6
48	1	1.2	0.6
	2	3.4	1.6
	3	3.2	1.5
68	1	2.1	1.0
	2	5.7	2.7
	3	5.5	2.6
88	1	3.3	1.6
	2	12.9	6.1
	3	12.5	5.9
108	2	22.2	10.5
	3	21.8	10.3
128	2	33.8	16.0
	3	33.4	15.8
148	2	44.0	20.8
	3	43.1	20.4
168	2	73.5	34.8
	3	72.1	34.1



Oil level



Ventilation



Oil drain

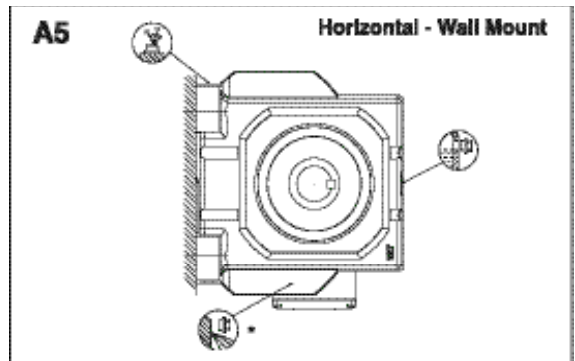

A6

Unit Size	Reduction Stage	Pints	Liters
38	1	0.5	0.3
	2	1.3	0.6
	3	1.9	0.9
48	1	1.0	0.5
	2	2.7	1.3
	3	3.0	1.4
68	1	2.2	1.1
	2	4.9	2.3
	3	5.1	2.4
88	1	3.4	1.6
	2	11.2	5.3
	3	11.4	5.4
108	2	19.7	9.3
	3	20.1	9.5
128	2	29.8	14.1
	3	31.3	14.8
148	2	38.7	18.3
	3	40.4	19.1
168	2	63.6	30.1
	3	65.9	31.2

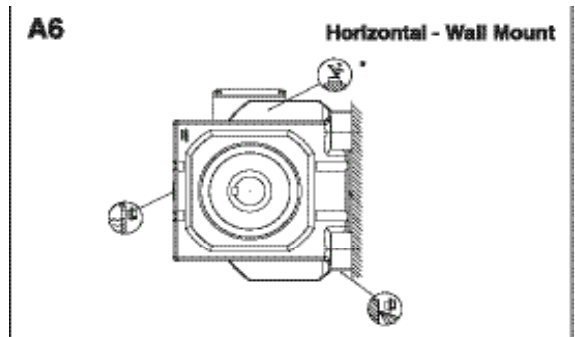

ILH 38 units are sealed for life and furnished with only one plug for filling and draining.

NOMENCLATURE PAGE ILH-4	OVERHUNG LOADS PAGE ILH-11	SELECTION GEARMOTOR PAGE ILH-78	WEIGHTS PAGE ILH-343
----------------------------	-------------------------------	------------------------------------	-------------------------

MOUNTING POSITIONS



Table of Old vs New Mounting Positions

	A1	A2	A3
ILH (HB)	B3	V6	B8
ILH (HF)	B5	V3	B8-01

	A4	A5	A6
ILH (HB)	V5	B6	B7
ILH (HF)	V1		

Shaded A2 mounting is not a recommended mounting position due to the weight of oil on the high speed input seal.

NOMENCLATURE PAGE ILH-4	OVERHUNG LOADS PAGE ILH-11	SELECTION GEARMOTOR PAGE ILH-78	WEIGHTS PAGE ILH-343
----------------------------	-------------------------------	------------------------------------	-------------------------

QUANTIS IN-LINE HELICAL (ILH) - STANDARD BEARINGS

Permissible Overhung Loads (OHL) at Service Factor SF =1.0

1. Calculation based on bearing life

$$F_{x \text{ perm.}_1} = F_R \text{ perm} \frac{y}{z + X} \quad [\text{lb}_f]$$

2. Calculation based on mechanical strength

$$F_{x \text{ perm.}_2} = \frac{a}{b + X} \quad [\text{lb}_f]$$

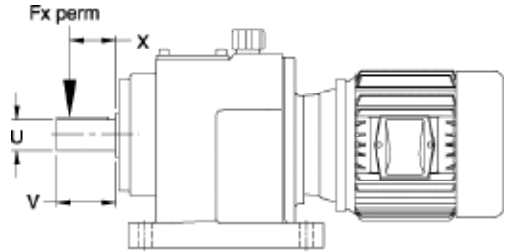

The data in the table below lists the permissible output shaft overhung load (OHL) when the load is located at mid shaft. To calculate the permissible OHL when the load is located at other positions, use the formulas above along with the data below.

Both equations 1 and 2 must be used to determine if the bearing or shaft strength limits the OHL. Limit the OHL to the lower of the 2 calculations.

Type Stages	y in (mm)	z in (mm)	a lbf-in (kNm)	b in (mm)	u in (mm)	v in (mm)	*	FR perm. (lbf) for x = v/2 for output speeds n2 in RPM							
								n2 ≤ 16	n2 ≤ 25	n2 ≤ 40	n2 ≤ 63	n2 ≤ 100	n2 ≤ 160	n2 ≤ 250	≤ 400
H_38 (2/3)	4.173	3.189	1496	0	1.000	1.97	ccw	1695	1432	1234	881	546	416	279	250
	(106)	(81)	(169)	(0)	(25)	(50)	cw	1625	1360	1167	937	710	569	407	385
	4.370	3.189	1859	0.63	1.250	2.36	ccw	1619	1358	1117	762	472	360	241	230
	(111)	(81)	(210)	(16)	(30)	(60)	cw	1551	1299	1115	895	614	492	351	351
H_48 (2/3)	5.315	4.134	2346	0	1.250	2.36	ccw	2810	2354	1992	1517	1142	937	919	617
	(135)	(105)	(265)	(0)	(30)	(60)	cw	2700	2246	1884	1533	1270	1095	967	779
	5.709	4.134	4417	0.748	1.625	3.15	ccw	2617	2192	1801	1293	973	798	785	529
	(145)	(105)	(499)	(19)	(40)	(80)	cw	2513	2091	1753	1427	1182	989	899	664
H_68 (2/3)	6.693	5.098	4992	0	1.625	3.15	ccw	3844	3091	2765	1940	1306	962	1057	763
	(170)	(129.50)	(564)	(0)	(40)	(80)	cw	4186	3437	3174	2347	1715	1344	1308	986
	7.087	5.098	8346	0.906	2.125	3.94	ccw	3516	2828	2529	1774	1194	879	967	677
	(180)	(129.50)	(943)	(23)	(50)	(100)	cw	3828	3143	2902	2147	1569	1230	1196	873
H_88 (2/3)	8.228	6.26	9559	0	2.125	3.94	ccw	7915	6643	5712	4773	3437	2954	2252	2700
	(209)	(159)	(1080)	(0)	(50)	(100)	cw	7609	6337	5346	4471	3599	3087	2605	2507
	8.622	6.26	13569	0.827	2.375	4.72	ccw	7553	6339	5451	4554	3325	2855	2178	2543
	(219)	(159)	(1533)	(21)	(60)	(120)	cw	7261	6047	5101	4267	3435	2945	2486	2392
H_108 (2/3)	9.082	7.441	17348	0	2.375	4.72	ccw	11965	10447	9104	7958	6899	5669	4745	3965
	(249)	(189)	(1960)	(0)	(60)	(120)	cw	9128	7619	6262	5138	4288	4037	3705	3312
	10.196	7.441	17968	1.142	2.875	5.51	ccw	11483	10060	8743	7429	6639	5456	4566	3814
	(259)	(189)	(2030)	(29)	(70)	(140)	cw	8779	7326	6023	4940	4126	3882	3557	3185
H_128 (2/3)	12.027	9.271	24783	0	2.875	5.51	ccw	16149	14131	12301	10779	9224	7590	6350	5311
	(305.50)	(235.50)	(2800)	(0)	(70)	(140)	cw	11784	9782	7975	6465	5579	5306	4886	4392
	12.617	9.271	40715	1.181	3.625	6.69	ccw	15397	13460	11736	10287	8791	7237	6061	5056
	(320.50)	(235.50)	(4600)	(30)	(90)	(170)	cw	11235	9322	7598	6159	5321	5054	4658	4186
H_148 (2/3)	13.424	10.078	58948	0	3.625	6.69	ccw	18922	16576	14429	12622	10467	8707	7332	6165
	(341)	(256)	(6660)	(0)	(90)	(170)	cw	14204	11828	9680	7912	7373	6752	6088	5382
	14.212	10.078	53991	1.29	4.000	8.27	ccw	17761	15664	13623	11928	9898	8208	6921	5825
	(361)	(256)	(6100)	(33)	(100)	(210)	cw	13417	11166	9149	7468	6967	6384	5751	5083
H_168 (2/3)	16.554	12.401	73463	0	4.000	8.27	ccw	54838	47232	40320	34650	31412	28075	25073	22079
	(420.50)	(315.50)	(8300)	(0)	(100)	(210)	cw	47825	40318	33399	27888	27156	25410	23337	21001
	16.554	12.401	88510	1.299	4.750	8.27	ccw	54838	47232	40320	34650	31412	28075	25073	22079
	(420.50)	(315.50)	(10000)	(30)	(120)	(210)	cw	47825	40318	33399	27888	27156	25410	23337	21001

* Direction of rotation with view on output shaft
To convert lbf to Newtons (N), multiply by 4.448

bold - Standard Shaft

cw = clockwise

ccw = counter clockwise

NOMENCLATURE PAGE ILH-4	MOUNTING POSITIONS PAGE ILH-7	SELECTION GEARMOTOR PAGE ILH-78	WEIGHTS PAGE ILH-343
----------------------------	----------------------------------	------------------------------------	-------------------------

OVERHUNG LOADS

QUANTIS

QUANTIS IN-LINE HELICAL (ILH) - HEAVY DUTY BEARINGS

Permissible Overhung Loads (OHL) at Service Factor SF =1.0

1. Calculation based on bearing life

$$F_x \text{ perm.}_1 = F_R \text{ perm} \frac{y}{z + X} \quad [\text{lb}_i]$$

2. Calculation based on mechanical strength

$$F_x \text{ perm.}_2 = \frac{a}{b + X} \quad [\text{lb}_i]$$

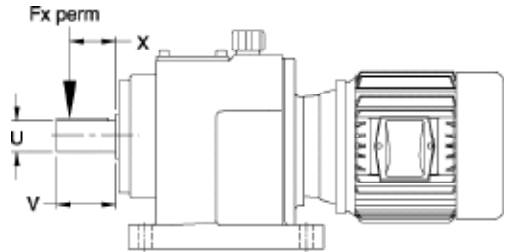

The data in the table below lists the permissible output shaft overhung load (OHL) when the load is located at mid shaft. To calculate the permissible OHL when the load is located at other positions, use the formulas above along with the data below.

Both equations 1 and 2 must be used to determine if the bearing or shaft strength limits the OHL. Limit the OHL to the lower of the 2 calculations.

Type Stages	y in (mm)	z in (mm)	a lbf-in (kNmm)	b in (mm)	u in (mm)	v in (mm)	*	FR perm. (lbf) for x = v/2 for output speeds n2 in RPM														
								≤ 16	≤ 25	≤ 40	≤ 63	≤ 100	≤ 160	≤ 250	≤ 400							
H_38 (2/3)	4.173	3.189	1100	0	1.000	1.97	ccw	NOT AVAILABLE														
	(106)	(81)	(124.3)	(0)	(25)	(50)	cw															
	4.370	3.189	1859	0.630	1.250	2.36	ccw															
(111)	(81)	(210)	(16)	(30)	(60)	cw																
5.315	4.134	2346	0	1.250	2.36	ccw																
(135)	(105)	(265)	(0)	(30)	(60)	cw																
5.709	4.134	4417	0.748	1.625	3.15	ccw																
(145)	(105)	(499)	(19)	(40)	(80)	cw																
6.693	5.098	4992	0	1.625	3.15	ccw	5528									5358	5183	5019	4857	4723	4618	4480
(170)	(129.50)	(564)	(0)	(40)	(80)	cw	5528									5358	5184	5021	4861	4682	4457	4108
7.087	5.098	7019	0.906	2.125	3.94	ccw	6127	5934	5738	5557	5372	5201	4779	4231								
(180)	(129.50)	(793)	(23)	(50)	(100)	cw	6110	5919	5724	5543	5015	4422	4208	3877								
8.228	6.260	9559	0	2.125	3.94	ccw	8111	7859	7273	6569	4226	4886	5089	4752								
(209)	(159)	(1080)	(0)	(50)	(100)	cw	8111	7859	7606	7364	7311	6944	6819	6141								
8.622	6.260	13569	0.827	2.375	4.72	ccw	9114	8249	6520	5077	3792	4381	4559	4263								
(219)	(159)	(1533)	(21)	(60)	(120)	cw	9109	8819	8519	8240	7732	7231	6664	5858								
9.082	7.441	17348	0	2.375	4.72	ccw	14334	12682	10000	7733	5745	6304	6773	6725								
(249)	(189)	(1960)	(0)	(60)	(120)	cw	14334	14178	13991	12144	10104	9385	8971	8004								
10.196	7.441	17968	1.142	2.875	5.51	ccw	14262	11586	9135	7080	5257	5763	6199	6150								
(259)	(189)	(2030)	(29)	(70)	(140)	cw	14751	14596	13891	11676	9718	9025	8451	7700								
12.027	9.271	24783	0	2.875	5.51	ccw	17484	17302	17085	16838	16399	16317	14897	13269								
(305.50)	(235.50)	(2800)	(0)	(70)	(140)	cw	17484	17302	17085	16838	13671	13681	13120	12151								
12.617	9.271	40715	1.181	3.625	6.69	ccw	28475	27748	23636	15857	12379	15681	14195	12647								
(320.50)	(235.50)	(4600)	(30)	(90)	(170)	cw	27977	23544	19482	17958	14884	13031	12498	11595								
13.424	10.078	42564	0	3.625	6.69	ccw	34383	34052	30826	26392	23276	20962	18802	16627								
(341)	(256)	(4809)	(0)	(90)	(170)	cw	34383	31301	26056	21664	19518	18604	17281	15673								
14.212	10.078	53991	1.29	4.000	8.27	ccw	31492	31171	29113	24933	21987	19800	17764	15703								
(361)	(256)	(6100)	(33)	(100)	(210)	cw	31461	29562	24610	20436	18441	17581	16329	14799								
16.554	12.401	73463	0	4.000	8.27	ccw	NOT AVAILABLE															
(420.50)	(315.50)	(8300)	(0)	(100)	(210)	cw																
16.554	12.401	88510	1.299	4.750	8.27	ccw																
(420.50)	(315.50)	(10000)	(30)	(120)	(210)	cw																

* Direction of rotation with view on output shaft
1N = 0.2248 lbf

bold - Standard Shaft
cw = clockwise

ccw = counter clockwise

NOMENCLATURE PAGE ILH-4	MOUNTING POSITIONS PAGE ILH-7	SELECTION GEARMOTOR PAGE ILH-78	WEIGHTS PAGE ILH-343
----------------------------	----------------------------------	------------------------------------	-------------------------