

# Instruction Manual for SLEEVOIL Oil Level and Filtration System (OLF-2)

These instructions must be read thoroughly before installing or operating this product.

**WARNING:** To ensure that drive is not unexpectedly started, turn off and lock out or tag power source before proceeding, failure to observe these precautions could result in bodily injury.

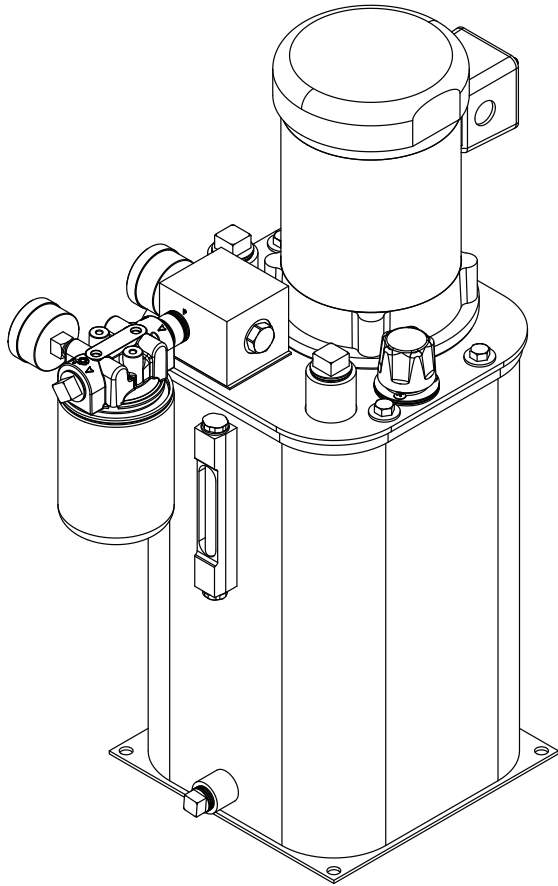

Figure 1 - OLF-2

**WARNING:** Because of the possible danger to person(s) or property from accidents which may result from the improper use of products, it is important that correct procedures be followed: Products must be used in accordance with the engineering information specified in the catalog. Proper installation, maintenance and operation procedures must be observed. The instructions in the instruction manuals must be followed. Inspections should be made as necessary to assure safe operation under prevailing conditions. Proper guards and other suitable safety devices or procedures as may be desirable or as may be specified in safety codes should be provided, and are neither provided by Baldor Electric Company nor are the responsibility of Baldor Electric Company. This unit and its associated equipment must be installed, adjusted and maintained by qualified personnel who are familiar with the construction and operation of all equipment in the system and the potential hazards involved. When risk to persons or property may be involved, a holding device must be an integral part of the driven equipment beyond the speed reducer output shaft.

## INSTALLATION

1. Verify SLEEVOIL series and bore size prior to installation of oil level and filtration system (OLF-2 System).

**NOTE:** One OLF-2 system supports enough oil flow for two SLEEVOIL bearings.

2. Shut down the main fan by following the manufacturer's instructions.

**WARNING:** To ensure that fan is not unexpectedly started, turn off and LOCK OUT and tag power source before proceeding. Failure to observe these precautions could result in bodily injury.

3. Place the OLF-2 system below the circulating oil drain holes in the bearings so that at least a 15° drain line slope is achieved to allow for adequate oil return. Circulating oil drain hole locations are designated in the SLEEVOIL Instruction Manuals, available at [www.baldor.com](http://www.baldor.com).
4. Mount the OLF-2 system vertically (as pictured) on a stable base.

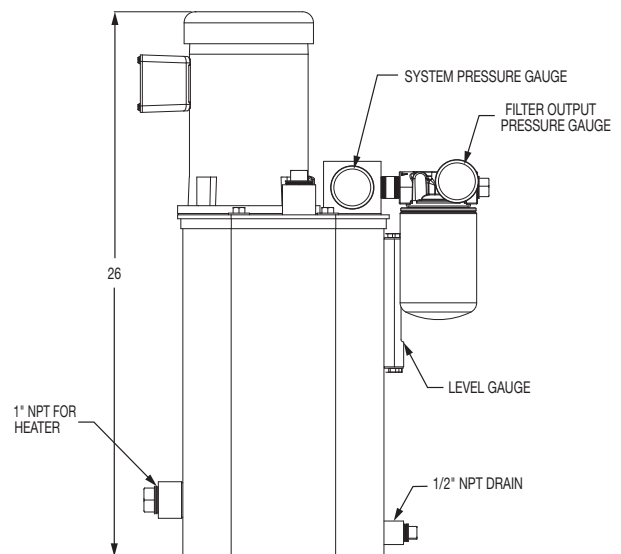
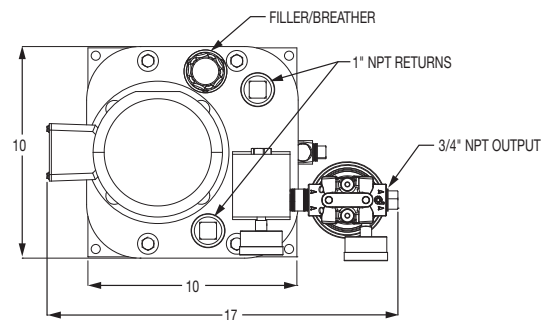
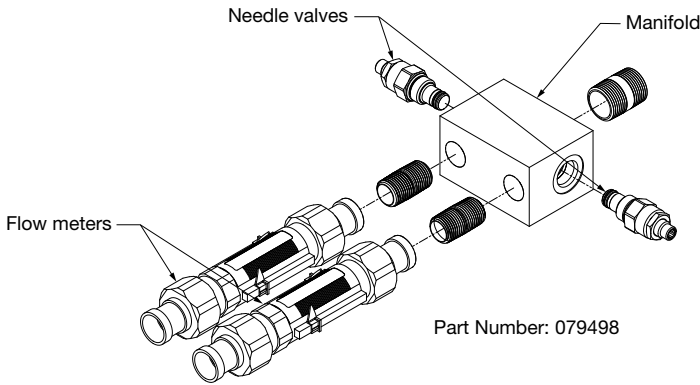

Figure 2 - OLF-2 Dimensions

- Connect an oil supply line (not included) from the 3/4" NPT (female) output of the OLF-2 system to the circulating oil inlets on the housings. Use a Tee fitting at the OLF-2 system output to ensure both bearings get an equal supply of oil. Connection details for each type of SLEEVOIL bearing are provided below.

**NOTE: All plumbing should be cleaned and flushed before being connected to the bearings.**

- Install a needle valve and flow meter on each supply line in order to verify oil flow to the bearings.



**Figure 3 - Optional Flow Meter Kit**

**NOTE: It is recommended to install a 5 psi check valve if total line length is greater than 10 feet. A check valve will prevent oil in the lines from returning to and overflowing the OLF-2 oil reservoir when the system is off.**

**R-Series 1-7/16" – 3-7/16"**

The circulating oil inlet is a tapped hole through the plunger screw. Check Table 1 to ensure that the bearings have the correct plunger screw. If replacement is necessary, install the new plunger screw per appropriate SLEEVOIL Instruction Manual.

**Table 1 - R-Series Oil Inlets for the OLF-2 System**

Bore Size	Plunger Screw Modified For Circulating Oil (Part Number)
1-7/16"	422392*
1-11/16" – 1-15/16"	422393*
2-3/16"	422394*
2-7/16"	422395*
2-11/16" – 2-15/16"	422397*
3-7/16"	422398*

\* Only if pillow block was manufactured prior to 1988 is new plunger screw required.

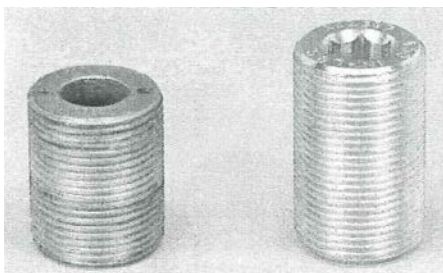

Plunger Screw Prior to 1988 Plunger Screw 1988 to Present

**Figure 4 - Plunger Screw**

The user is required to provide a connection adapter to connect the supply lines to the SLEEVOIL circulating oil inlets. (See Table 2)

**Table 2 - R-Series 1-7/16" thru 3-7/16"**

Bore Size R Series	Number of Circulating Oil Inlets	Circulating Oil Inlet NPT Size (Female)	Circulating Oil Drain Hole NPT Size	Alternate. Oil Gauge Hole NPT Size
1-7/16"	1	1/4"	–	1/2"
1-11/16"	1	1/4"	–	1/2"
1-15/16"	1	1/4"	–	1/2"
2-3/16"	1	1/4"	–	1/2"
2-7/16"	1	1/4"	–	1/2"
2-11/16"	1	1/4"	–	1/2"
2-15/16"	1	1/4"	–	1/2"
3-7/16"	1	1/4"	1"	3/4"

**R-Series 3-15/16" thru 14"**

A Circulating Oil Inlet Kit is required for each pillow block for the OLF-2 installation. Install the Circulating Oil Inlet Kit as shown in the appropriate SLEEVOIL Instruction Manual.

Circulating Oil Inlet Kit	Part Number
R Series 3-15/16" Circulating Oil Inlet Kit	432153
R Series 4-7/16" thru 4-15/16" Circulating Oil Inlet Kit	430198
R Series 5-7/16" thru 12" Circulating Oil Inlet Kit	430155

The user shall provide connection adapters and Tee fittings to connect the supply lines to the circulating oil inlets. A Tee fitting is required at the inlet connection because these pillow blocks have 2 circulating oil inlets. The Tee fitting ensures both oil inlets receive an equal amount of oil. Flexible connections from the Tee fitting to the oil inlets are recommended. (See Table 3 for inlet connection size)

**Table 3 - R-Series 3-15/16" - 14"**

Bore Size	Number of Circulating Oil Inlets	Circulating Oil Inlet NPT Size (Male)	Circulating Oil Drain Hole NPT Size		Alt. Oil Gauge Hole NPT Size
			STL	SSL	
3-15/16" PL-XC	2	1/4"	3/4"	3/4"	1/2"
4-7/16" PL-XC	2	1/4"	3/4"	1"	1/2"
4-15/16" PL-XC	2	1/4"	1"	1-1/4"	1/2"
5-7/16" PL-XC	2	1/4"	1"	1-1/4"	3/4"
6" PL-XC	2	1/4"	1"	1-1/4"	3/4"
7" PL-XC	2	1/4"	1-1/4"	1-1/4"	3/4"
8" PL-XC	2	1/4"	1-1/4"	1-1/4"	3/4"
9" PL	2	1/4"	1-1/4"	1-1/4"	3/4"
9" XC	2	1/4"	1-1/2"	1-1/2"	3/4"
10" PL	2	1/4"	1-1/4"	1-1/4"	3/4"
10" XC	2	1/4"	1-1/2"	1-1/2"	3/4"
12" PL	2	1/4"	1-1/2"	1-1/2"	3/4"
14" PL	2	1/4"	1-1/2"	1-1/2"	3/4"

## RTL Series

A Circulating Oil Inlet Kit is required for each pillow block for the OLF-2 installation. Install the Circulating Oil Inlet Kit as shown in the SLEEVOIL Instruction Manual.

Circulating Oil Inlet Kit	Part Number
RTL 3-7/16" thru 5-7/16" Circulating Oil Inlet Kit Part	132203
RTL 6" thru 12" Circulating Oil Inlet Kit Part	132205

The user shall provide connection adapters and Tee fittings to connect the supply lines to the circulating oil inlets. A Tee fitting is required at the inlet connection because these pillow blocks have 2 circulating oil inlets. The Tee fitting ensures both oil inlets receive an equal amount of oil. Flexible connections from the Tee fitting to the oil inlets are recommended. (See Table 4 for inlet connection size)

Table 4 - RTL Series

Bore Size RTL Series	Number of Circulating Oil Inlets	Circulating Oil Inlet NPT Size (Male)	Circulating Oil Drain Hole NPT Size	Alternate Oil Gauge Hole NPT Size
3-7/16"	2	1/4"	1-1/2"	3/4"
3-15/16"	2	1/4"	1-1/2"	3/4"
4-7/16"	2	1/4"	1-1/2"	3/4"
4-15/16"	2	1/4"	2"	3/4"
5-7/16"	2	1/4"	2"	3/4"
6"	2	3/8"	2"	3/4"
7"	2	3/8"	2"	3/4"
8"	2	3/8"	2"	3/4"
9"	2	3/8"	2"	3/4"
10"	2	3/8"	2-1/2"	3/4"
12"	2	3/8"	2-1/2"	3/4"

## RXT Series

A Circulating Oil Inlet Kit is NOT required for these pillow blocks. The circulating oil inlets are machined into the housing and are plugged with pipe plugs as shown in the SLEEVOIL Instruction Manual.

The supply line should be connected to the two inlets on the downswing side of the pillow block for base loaded applications, or to the two inlets on the upswing side for cap loaded applications.

The user shall provide connection adapters and Tee fittings to connect the supply lines to the SLEEVOIL circulating oil inlets. A Tee fitting is required at the inlet connection because these pillow blocks have 2 circulating oil inlets. The Tee fitting ensures both oil inlets receive an equal amount of oil. (See Table 5 for inlet connection size)

Table 5 - RXT Series

Bore Size RXT Series	Number of Circulating Oil Inlets	Circulating Oil Inlet NPT Size (Female)	Circulating Oil Drain Hole NPT Size	Alternate Oil Gauge Hole NPT Size
2-15/16"	2	1/2"	1-1/4"	3/4"
3-7/16"	2	1/2"	1-1/4"	3/4"
3-15/16"	2	1/2"	2"	3/4"
4-7/16"	2	1/2"	2"	3/4"
4-15/16"	2	1/2"	2"	3/4"
5-7/16"	2	1/2"	2"	3/4"
6"	2	3/4"	2-1/2"	3/4"
7"	2	3/4"	2-1/2"	3/4"
8"	2	3/4"	2-1/2"	3/4"
9"	2	3/4"	2-1/2"	3/4"
10"	2	1"	2-1/2"	3/4"
12"	2	1"	2-1/2"	3/4"

- Connect oil return lines (not included) from the circulating oil drain holes of the housings (not the housing drains) to the 1" NPT (female) returns on the OLF-2 system. Circulating oil drain hole locations are designated in the SLEEVOIL Instruction Manual. Drain hole sizes for each type of pillow block are provided in the tables above.

**NOTE: The circulating oil drain holes are positioned to maintain the proper static oil level in the housings if the circulating oil is off and the circulating oil drain holes are open. This allows the oil rings to operate and supply oil to the bearings in case the OLF-2 system is shut down or stops.**

**NOTE: Drain piping should be vented and of adequate size to drain oil from the bearings at the same rate as the incoming oil flow. The circulating oil drains must be directed straight down into a return drain sloping away at a 15° or greater angle.**

- Fill up the OLF-2 system reservoir by monitoring the oil level gauge. The OLF-2 system reservoir will hold 5 gallons of oil.
 

**NOTE: Since the satisfactory operation of the bearing depends almost entirely on the oil film being maintained between the shaft and bearing liner surface, the use of a high quality oil from a reputable manufacturer cannot be overemphasized. Use a high grade straight mineral oil with rust and oxidation (R & O) inhibitors and antifoam agents. Check construction drawings or equipment instruction manual for proper oil. Oil viscosity is determined by the equipment manufacturer and normally specified on the construction drawing or in the operating manual.**
- Fill the bearings with oil to their recommended level. (See SLEEVOIL Instruction Manuals).
- Following local electrical codes, connect the OLF-2 electric motor to a power supply. The power supply should match the input requirements of the motor selected for the OLF-2 system. Quickly jog the motor on and off to check for the correct rotation indicated by the arrow on top of the motor (reverse direction will cause damage to the pump).
- Before starting the OLF-2 system, jog the motor four or more times to prime the pump. Start the OLF-2 system and allow the oil to circulate. Be sure to monitor the oil level in the tank to ensure that the oil returns from the bearing housings. If air in the return lines becomes a problem, it may be necessary to loosen a fitting close to the problem in order to bleed the air out of the lines.
- Monitor the oil level gauges on the bearing housings to ensure that the oil level is maintained.

**NOTE: If the oil level in either bearing housing continuously rises, this means that the oil is not draining sufficiently. Verify proper size and slope of oil return lines.**

- If the oil level in both the OLF-2 system and the bearings are stable, start the main fan. Continue to monitor the oil level in both the bearings and the OLF-2 system to ensure that the oil still flows under the dynamic condition.

**WARNING: Do not start the fan if the oil temperature is too low. This can cause result in an insufficient oil film in the bearing which may result in bearing failure. DODGE recommends the oil temperature to be 70°F or above before starting the fan. Optional heater/thermostat assemblies are available for the OLF-2 system.**

**Optional Heater/Thermostat Assemblies:**

- 260W X 120V—Part # 434725
- 260W X 240V—Part # 434726

**MAINTENANCE AND FILTER REPLACEMENT:**

Periodically check the oil level in the bearing housings and the OLF-2 system to ensure proper operation.

Most foreign material in a system flushes to the reservoir after the first few hours of operation. We recommend that you drain the tank, replace the fluid, change the filter, and clean the suction strainer after 3-5 hours of operation. After the initial cleaning, the strainer should be cleaned at a minimum of every 4000 hours of operation. More frequent cleaning is required if the system is used in a highly contaminated atmosphere such as a foundry or paper mill.

After the initial replacement, the supply line filter should be replaced periodically as required by operating conditions. The pressure difference between the two pressure gauges will increase as the filter becomes clogged. The filter bypass is set at a differential pressure of 25psi. Check the pressure gauges between filter changes to ensure filter is not being bypassed.

Good preventative maintenance is the best insurance against unscheduled downtime. Unscheduled downtime is usually more expensive than preventive maintenance.

**Optional Filter Additions:**

- Duplex filter head with two filters.
- Desiccant filter with moisture absorbing capability can be added in series with the standard filter.

**REPLACEMENT FILTER:**

Use OLF-2 replacement oil filter Part # 078202.

**GENERAL INFORMATION:**

- Oil Supply Line Connection:** 3/4" NPT at the filter outlet (female)
- Oil Return Line Connection:** Two 1" NPT connections (female)
- Flow:** 2 GPM @1800 RPM

**Electric Motor Information:**

OLF-2 System Part Number	Motor Information
077587	1/2 HP @1725 RPM Single Phase—115/230 VAC
077588	1/2 HP @1725 RPM Three Phase—230/460 VAC
077589	1/2 HP @1725 RPM Three Phase—208-230/460 VAC (Explosion Proof Motor)
077484	1/2 HP @1725 RPM Three Phase—575 VAC (Canada)

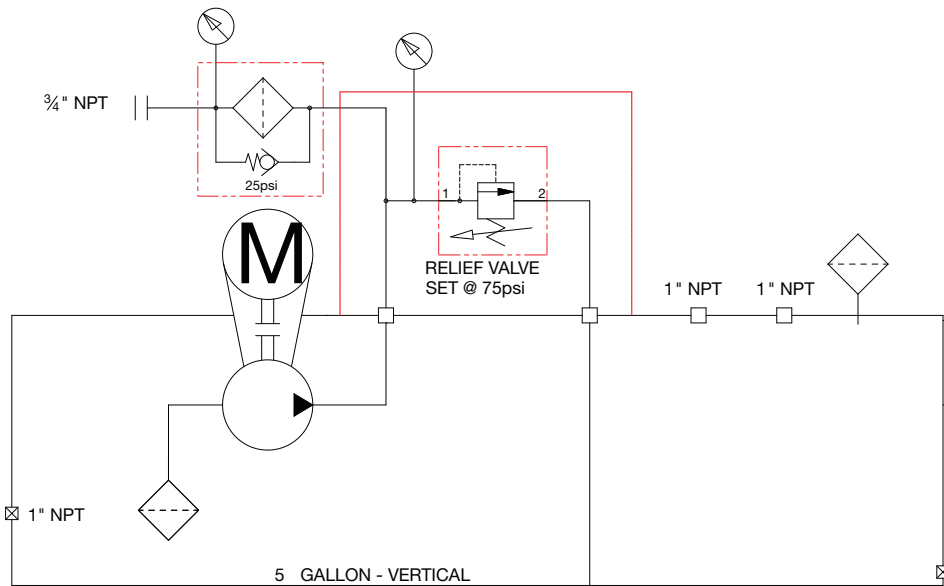

**Figure 5 - Hydraulic Schematic**



P.O. Box 2400, Fort Smith, AR 72902-2400 U.S.A., Ph: (1) 479.646.4711, Fax (1) 479.648.5792, International Fax (1) 479.648.5895

**Dodge Product Support**

6040 Ponders Court, Greenville, SC 29615-4617 U.S.A., Ph: (1) 864.297.4800, Fax: (1) 864.281.2433

[www.baldor.com](http://www.baldor.com)

