

Instruction Manual

DODGE® Proximity Switch Based Speed Sensor

These instructions must be read thoroughly before installation or operation.

Preparing a TAF Housing

The face of the Smart S-1 unit is predrilled and tapped for mounting the Speed Sensor End Cover. A proximity switch based Speed Sensor Kit is required for monitoring the speed of the bearing. Mount the bearing per the bearing installation instructions and tighten the proximity collar set screw before mounting the end cover. To mount the Speed Sensor End Cover, apply RTV on the end cover, place the end cover against the mounting surface on the housing, and secure the cover in place using the screws supplied with the end cover kit. After the end cover is secured to the housing, follow the installation for the speed sensor kit for mounting and wiring instructions.

Installing a Proximity Switch Based Speed Sensor with a TAF Smart Housing

1. Rotate the bearing until the raised portion of the collar aligns with the hole for the proximity switch. Screw the proximity switch into the end cover until it bottoms out on the raised portion of the collar. (Refer to Figure 1.)
2. Back the proximity switch out 1-1/4 turn to provide 0.050" clearance gap.
3. Tighten the jam nut for the proximity switch until it is flush with the end cover. Tighten to 75 in-lb for 12mm AC proximity switches and 25 in-lb for 12mm DC proximity switches.
4. If the supplied three-pin connector is to be used, connect the leads on the proximity switch to the same-colored lead on the connector using the supplied wire nuts. Otherwise, connect the customer supplied process wires to the leads of the proximity switch, and protect the wires using flex conduit and a 1/2" liquid-tight electrical fitting.

NOTE: The black lead is the signal wire, the brown lead is the proximity switch power, and the blue lead is the proximity switch ground. (Refer to Figure 4).

5. Mount one gasket between end cover and spacer (if required) and one gasket between the cover over the proximity switch spacer and secure to the cover using four socket head screws and lock washers to housing. The socket head screws should be tightened to a torque of 65-75 in-lb.

Installing a Proximity Switch Based Speed Sensor with a USAF Smart Housing

The USAF/USN Cast Closed Smart Housings used with the speed sensor are predrilled to accept proximity switch kits. If the proximity switch kits are not going to be used, a plug kit is

WARNING: Because of the possible danger to person(s) or property from accidents which may result from the improper use of products, it is important that correct procedures be followed. Products must be used in accordance with the engineering information specified in the catalog. Proper installation, maintenance and operation procedures must be observed. The instructions in the instruction manuals must be followed. Inspections should be made as necessary to assure safe operation under prevailing conditions. Proper guards and other suitable safety devices or procedures, as may be desirable, or as may be specified in safety codes should be provided, and are neither provided by Baldor Electric Company, nor are the responsibility of Baldor Electric Company. This unit and its associated equipment must be installed, adjusted and maintained by qualified personnel who are familiar with the construction and operation of all equipment in the system and the potential hazards involved. When risks to persons or property may be involved, a holding device must be an integral part of the driven equipment beyond the speed reducer output shaft.

supplied with the housing. Apply RTV to the screws. The 12mm plug should be torqued to 30-35 in-lb and the #10-32 screws should be tightened to a torque of 65-75 in-lb.

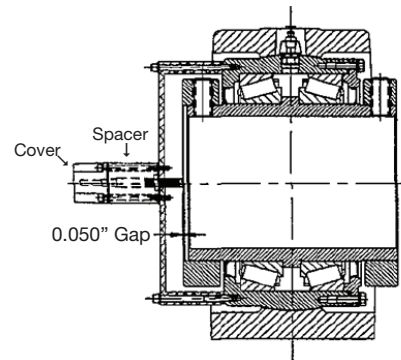

Figure 1 - TAF with Proximity Switch Installed to 0.050" Gap

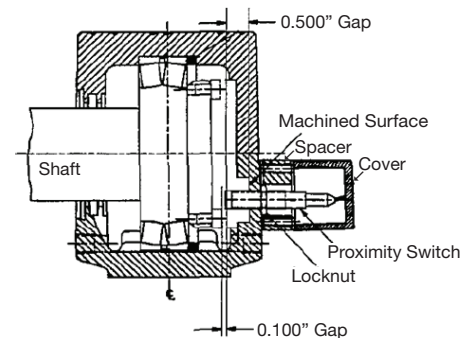

Figure 2 - USAF Smart Housing Proximity Switch Protruding 0.500" from the Machined Surface

The Proximity Switch is made to be used only on the Cast Closed end housing and the non-expansion bearing. For shaft sizes up to 5" misalignment must not exceed 1/2 degree. Misalignment for shaft sizes greater than 5" should not exceed 1/4 degree.

1. After lowering the shaft and bearing assembly into the lower half of the housing, place the stabilizing ring on the closed end side of the housing. Screw the proximity switch into the housing until it protrudes 1/2" from the machined surface of the cast closed end of the housing. (Refer to Figure 2).
2. Use the lock nut supplied with the Proximity Switch Kit to secure the proximity switch in the housing. Torque the lock nut to 75 in-lb for the 12mm AC Proximity Switch and 25 in-lb for the 12mm DC Proximity Switch.
3. Check the gap between the proximity switch and the raised portion of the proximity adapter nut to make sure it is 0.100 inch for the 12 mm proximity switch.



- If the supplied three-pin connector is to be used, connect the leads on the proximity switch to the same-colored lead on the connector using the supplied wire nuts. Otherwise, connect the customer supplied process wires to the leads of the proximity switch, and protect the wires using flex conduit and a 1/2" liquid-tight electrical fitting.

NOTE: The black lead is the signal wire, the brown lead is the proximity switch power, and the blue lead is the proximity switch ground. (Refer to Figure 4).

- Mount one gasket between housing and spacer (if required) and one gasket between the cover over the proximity switch spacer and secure to the housing using four socket head screws and lock washers. The socket head screws should be tightened to a torque of 65–75 in-lb.

Preparing a ISAF Housing

The face of the Smart ISAF housing is predrilled and tapped for mounting the speed sensor end cover. A proximity switch based speed sensor kit is required for monitoring the speed of the bearing. Mount the bearing per the bearing installation instructions to the point where the lockplate is to be installed. The proximity switch targets must be added to the face of the locknut to monitor the bearing speed. Two proximity switch targets and the necessary mounting hardware are supplied with the speed sensor end cover. Fasten the lockplate and proximity switch targets to the locknut with the supplied socket head cap screws and lock washers and torque the socket head cap screws to 110 in-lb. To mount the speed sensor end cover, apply RTV on the end cover, place the end cover against the mounting surface on the housing, and secure the end cover in place using the screws supplied with the end cover kit. After the end cover is secured to the housing, follow the installation instructions for mounting the speed sensor kit and the corresponding wiring instructions.

Installing a Proximity Switch Based Speed Sensor with an ISAF Smart Housing

- Rotate the bearing until a proximity switch target aligns with the proximity switch hole in the end cover. Screw the proximity switch into the end cover until it bottoms out on the target. (Refer to Figure 3).
- Back the proximity switch out 2-1/2 turns to provide a 0.100" gap between the end of the proximity switch and the targets.

- Tighten the jam nut for the proximity switch until it is flush with the end cover. Torque the jam nut to 75 in-lb for the 12 mm. AC proximity switches and 25 in-lb for the 12 mm. DC proximity switches.

- If the supplied 3-pin connector is to be used, connect the leads on the proximity switch, and protect the wires using flex conduit and a 1/2" liquid tight electrical fitting.

NOTE: The black lead is the signal wire, the brown lead is the proximity switch power, and the blue lead is the proximity switch ground. (Refer to Figure 4).

- Mount one gasket between the housing and spacer (if required) and one gasket between the cover over the proximity switch spacer. Secure the assembly to the housing using the four socket head cap screws and lock washers. The socket head cap screws should be tightened to a torque of 65–75 in-lb.

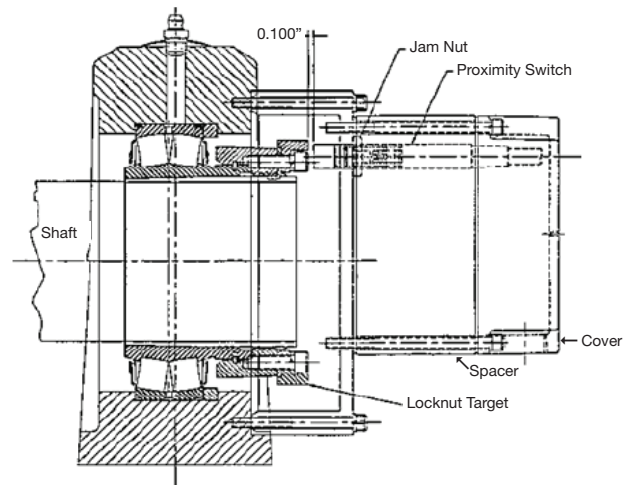

Figure 3 - ISAF Smart Housing Proximity Switch Installed to 0.100" Gap

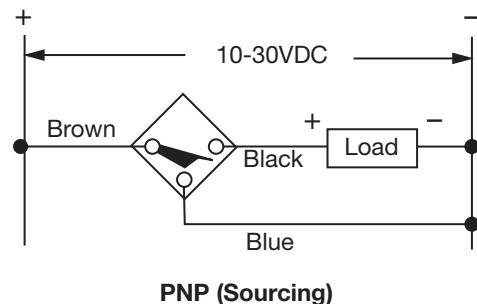
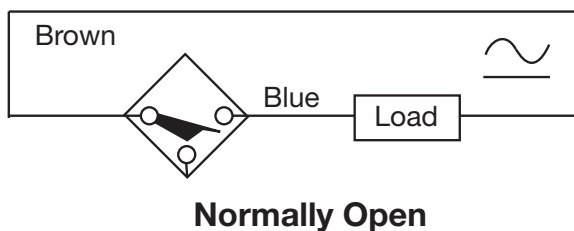

Figure 4 - Wiring Diagrams for AC Prox and DC Prox



World Headquarters

P.O. Box 2400, Fort Smith, AR 72902-2400 U.S.A., Ph: (1) 479.646.4711, Fax (1) 479.648.5792, International Fax (1) 479.648.5895

Dodge Product Support

6040 Ponders Court, Greenville, SC 29615-4617 U.S.A., Ph: (1) 864.297.4800, Fax: (1) 864.281.2433



www.baldor.com