

Instruction Manual

DODGE® Thermocouple and Vibration Kits

These instructions must be read thoroughly before installation or operation.

INSTALLATION INSTRUCTIONS

Thermocouple and Transmitter

When installed properly, the output of the thermocouple and transmitter is 4–20mA representing 0 to 250°F. To achieve this, the supply voltage to the transmitter must be between 8.5 and 35 volts and the maximum loop resistance should be less than:

$$R_{loop} < (V_{supply} - 8.5 \text{ volts}) / (0.02 \text{ amps})$$

For example, if a 24 volt supply is used then the loop resistance should be less than 775 ohms. To protect against voltage drops, 80% of the calculated value should be used.

Accelerometer

The accelerometer requires a supply voltage between 18 and 28 volts and an excitation current of 2 to 20 milliamps. The accelerometer produces a signal of ±5 volts representing ±50g (100mV/g). When used, the vibration transmitter requires a supply voltage of 24 volts and produces either ±5 volts representing ±50g or 4–20mA representing 1 inch per second depending on the wiring configuration (Figure 2).

Preparing the Housing

1. Place the two rubberized cork gaskets on top of the bearing housing or mounting plate supplied with the housing.
2. If a thermocouple is to be used, make sure the thermocouple is threaded through the hole near the center of the gaskets and that the holes for mounting the transmitter are aligned with the threaded holes on the top of the housing or mounting plate.
3. Fill the gap around the thermocouple with 100% silicon sealer.

Connecting Thermocouple to Temperature Transmitter

1. Place the transmitter 6 on top of the gaskets (Figure 1).
2. Using the plastic screw provided, secure the transmitter to the housing. Be careful not to over tighten the screw.
3. Attach the thermocouple white lead to terminal 3 and red lead to terminal 4 of the transmitter.
4. Connect the customer supplied process wire 5 to terminals 1 and 2 of the transmitter. Install a 1/2" liquid tight electrical fitting 3 on the sensor cover 1 using the hole on the side of the sensor cover.
5. Place the sensor cover on top of the gaskets and thread the process wire through the cover hole. Use a flex conduit to protect the process wire.
6. Secure the sensor cover using four socket head screws and lock washers provided. (Screws should be torqued to 65-75 in-lbs.)

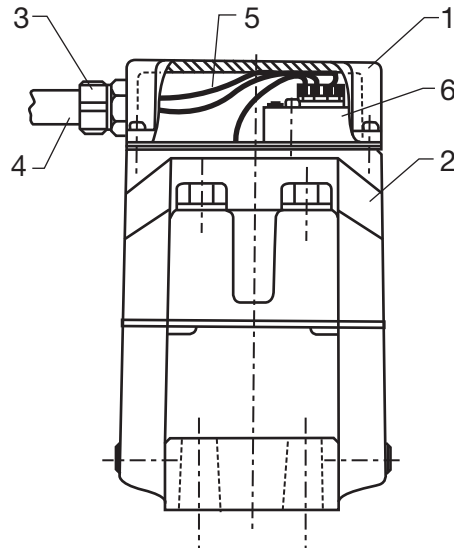

Figure 1 - Mounted Thermocouple Transmitter



Figure 2 - Thermocouple Transmitter Wiring

WARNING: Because of the possible danger to person(s) or property from accidents which may result from the improper use of products, it is important that correct procedures be followed: Products must be used in accordance with the engineering information specified in the catalog. Proper installation, maintenance and operation procedures must be observed. The instructions in the instruction manuals must be followed. Inspections should be made as necessary to assure safe operation under prevailing conditions. Proper guards and other suitable safety devices or procedures as may be desirable or as may be specified in safety codes should be provided, and are neither provided by Baldor Electric Company nor are the responsibility of Baldor Electric Company. This unit and its associated equipment must be installed, adjusted and maintained by qualified personnel who are familiar with the construction and operation of all equipment in the system and the potential hazards involved. When risk to persons or property may be involved, a fail safe device must be an integral part of the driven equipment beyond the speed reducer output shaft.



Connecting an Accelerometer

Note: If a thermocouple and accelerometer are to be installed together, the thermocouple transmitter must be installed first.

1. Connect the customer supplied process wire 1 to the leads on the accelerometer. Be sure to note which lead is connected to the red lead and which is connected to the black lead.
2. Install a 1/2" liquid tight electrical fitting 2 on sensor cover using the hole on the side of the sensor cover.
3. Place sensor cover with mounted accelerometer on the gaskets and thread the process wire through the cover hole. Use a flex conduit 3 to protect the process wire.
4. Secure the sensor cover using four socket head screws and lock washers provided (screws should be torqued to 65–75 in-lbs).
5. If a vibration transmitter is to be used, connect the process wire to the first two terminals 4 on the vibration transmitter. For the 4–20mA output, connect a new process wire to terminals 4 and 5 of the vibration transmitter 5; for the ± 5 volt output connect the new process wire to terminals 6 and 7 of the vibration transmitter 6. Connect a 24 volt supply to terminals 8 and 9 of the transmitter.

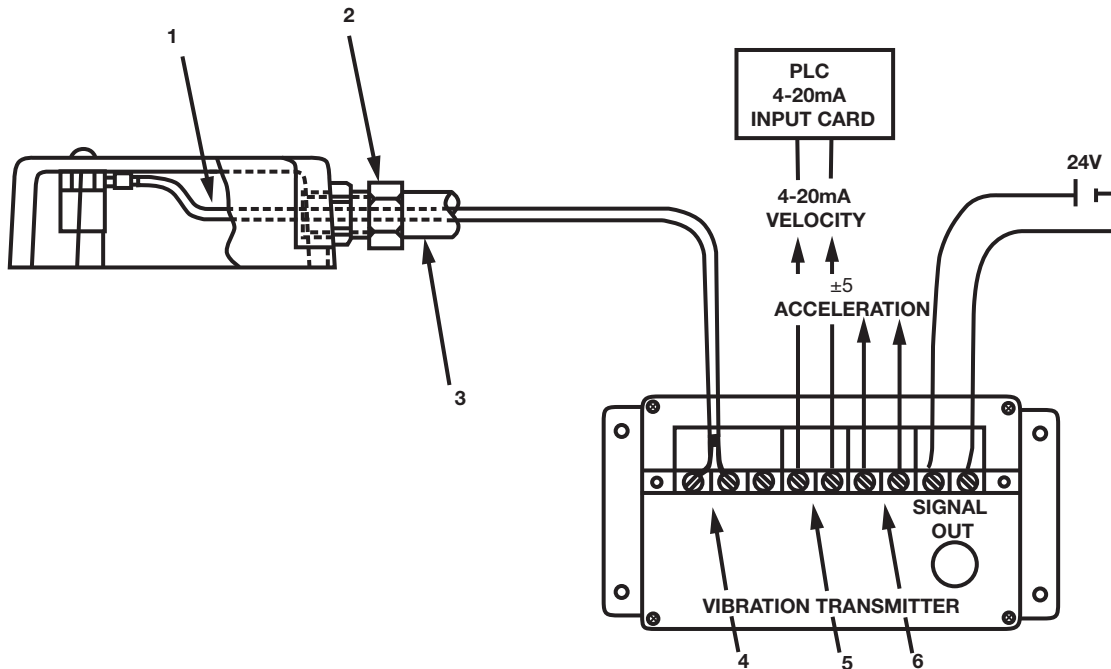

Figure 3 - Accelerometer Connected to Vibration Transmitter

BALDOR®

World Headquarters

P.O. Box 2400, Fort Smith, AR 72902-2400 U.S.A., Ph: (1) 479.646.4711, Fax (1) 479.648.5792, International Fax (1) 479.648.5895

Dodge Product Support

6040 Ponders Court, Greenville, SC 29615-4617 U.S.A., Ph: (1) 864.297.4800, Fax: (1) 864.281.2433

www.baldor.com

© Baldor Electric Company
MN3032 (Replaces 499041)



All Rights Reserved. Printed in USA.
4/10 TCP 15000