

DODGE COOL LUBE SYSTEMS Instruction and Lubrication Manual

Part Numbers 055860, 058530, 067669, 067912 and 068862

These instructions must be read thoroughly before installing or operating this product.

WARNING: To ensure the drive is not unexpectedly started, turn off and lock-out or tag power source before proceeding. Failure to observe these precautions could result in bodily injury.

WARNING: Only qualified personnel familiar with hydraulic and electrical installations, the construction and operation of this equipment, and the hazards involved should install, adjust, operate, and/or service it. Read and understand this manual in its entirety before proceeding. Failure to observe this precaution could result in severe bodily injury or loss of life.

System Parameters:

Supply Voltage:

Part Number	Motor	Heater & Switches
055860	120V/1 phase/60 Hz	N/A
058530	120V/1 phase/60 Hz	120V/1 phase/60 Hz
067669	460V/3 phase/60 Hz	120V/1 phase/60 Hz
067912	120V/1 phase/60 Hz	120V/1 phase/60 Hz
068862	460V/3 phase/60 Hz	120V/1 phase/60 Hz

Operating Temperature:

90°F to 130°F

* Pump Relief valve setting: 150 psi

* Bearing Relief valve setting 65 psi

Design flow rate except 068862 0.5 GPM

Design flow 068862 1 GPM

* Field Adjustable

WARNING: Because of the possible danger to person(s) or property from accidents which may result from the improper use of products, it is important that correct procedures be followed. Products must be used in accordance with the engineering information specified in the catalog. Proper installation, maintenance and operation procedures must be observed. The instructions in the instruction manuals must be followed. Inspections should be made as necessary to assure safe operation under prevailing conditions. Proper guards and other suitable safety devices or procedures, as may be desirable, or as may be specified in safety codes should be provided, and are neither provided by Baldor Electric Company, nor are the responsibility of Baldor Electric Company. This unit and its associated equipment must be installed, adjusted and maintained by qualified personnel who are familiar with the construction and operation of all equipment in the system and the potential hazards involved. When risks to persons or property may be involved, a holding device must be an integral part of the driven equipment beyond the speed reducer output shaft.

Installation:

Receiving & Inspection:

1. Carefully unpack the circulating oil system. Inspect the system for any damage during shipping before lifting it off the skid.
2. Report any damage to the carrier for claims.
3. Make sure that available voltage supply is within 10% of the system voltage.
4. Check all hydraulics to ensure that nothing came loose during shipping. Tighten as needed.
5. No alterations are allowed without authorization from Dodge. Unauthorized changes void the warranty.

Installation Instructions:

1. Place the unit in the designated area and anchor down using the specified bolts in the arrangement drawings.
2. Make sure that there is enough space around the unit to allow for servicing.
3. Connect oil supply and return lines to the bearings. Make sure to use the sizes recommended by the manufacturer. Please follow the guidelines for the sloping of the return lines recommended by the bearing manufacturer.
4. It is very important that the pipes used must be cleaned and flushed prior to installation. If the unit is not used for one month, the pipes should be cleaned again.
5. Fill the reservoir with clean oil (2 gallons for 055860 and 3 gallons for 058530, 067669, 067912 and 068862). Make sure the filler cap is placed back and tightened.

Electrical Hook Up:

Connect motor to the customer panel through the proper fuses, starter and overload protection using NEC and local electrical codes.

Operating Instructions:

1. All relief valves are preset at the factory. If other settings are required, consult Dodge Engineering.
2. Observe sight gauge 2 to ensure that oil is at proper level.
3. Turn on the power to the circulating oil system (Customer controls).
4. Make sure that the valves in the supply line to the bearings are open.
5. Jog the pump motor to see if the motor is rotating in the right direction as the arrow on top indicates.
6. Continue to jog pump motor to prime the pump.
7. Visually check the system for leaks and correct if necessary.
8. Confirm that there is flow by using the flow meters.
9. If there is no flow, check for leaks.
10. Balance the flow to the bearings using two needle valves as needed. The flows are set at .125 GPM at the factory for all models except 068862. Flow setting for 068862 is 0.4 GPM.



11. Make sure that the system pressure does not exceed 150 psi by watching the pump pressure gauge.
12. Make sure there are no leaks of any kind.
13. Turn off the pump.
14. Check oil level in the tank. The oil level will go down as the oil fills the bearing lines. If the lines are too long, additional oil may be needed to restore the proper level.
15. Once the flow to the bearings are set, the unit is ready for operation.
16. Periodically check the oil filter clog indicator.

Maintenance

1. Filters should be inspected and dirty elements removed. The filter should initially be replaced after 10 hours and then as needed.
2. Oil level must be monitored on a continuous basis. Check the oil level very closely in the first few hours and after that every 100 hours.
3. The switches provided with the system should protect the system against catastrophic failure; however, common sense maintenance should be practiced at all times.
4. A periodic maintenance schedule should be practiced.
5. Always use new, clean filtered oil to bring oil level up.
6. Always use clean funnels.
7. Always replace the filler cap and tighten
8. Always watch for any change in performance to avert any unscheduled shut down.
9. Always watch for leaks or noise change.

NOTE: Drawings provided for stocked items. Contact Baldor Dodge Engineering for drawings of other systems.

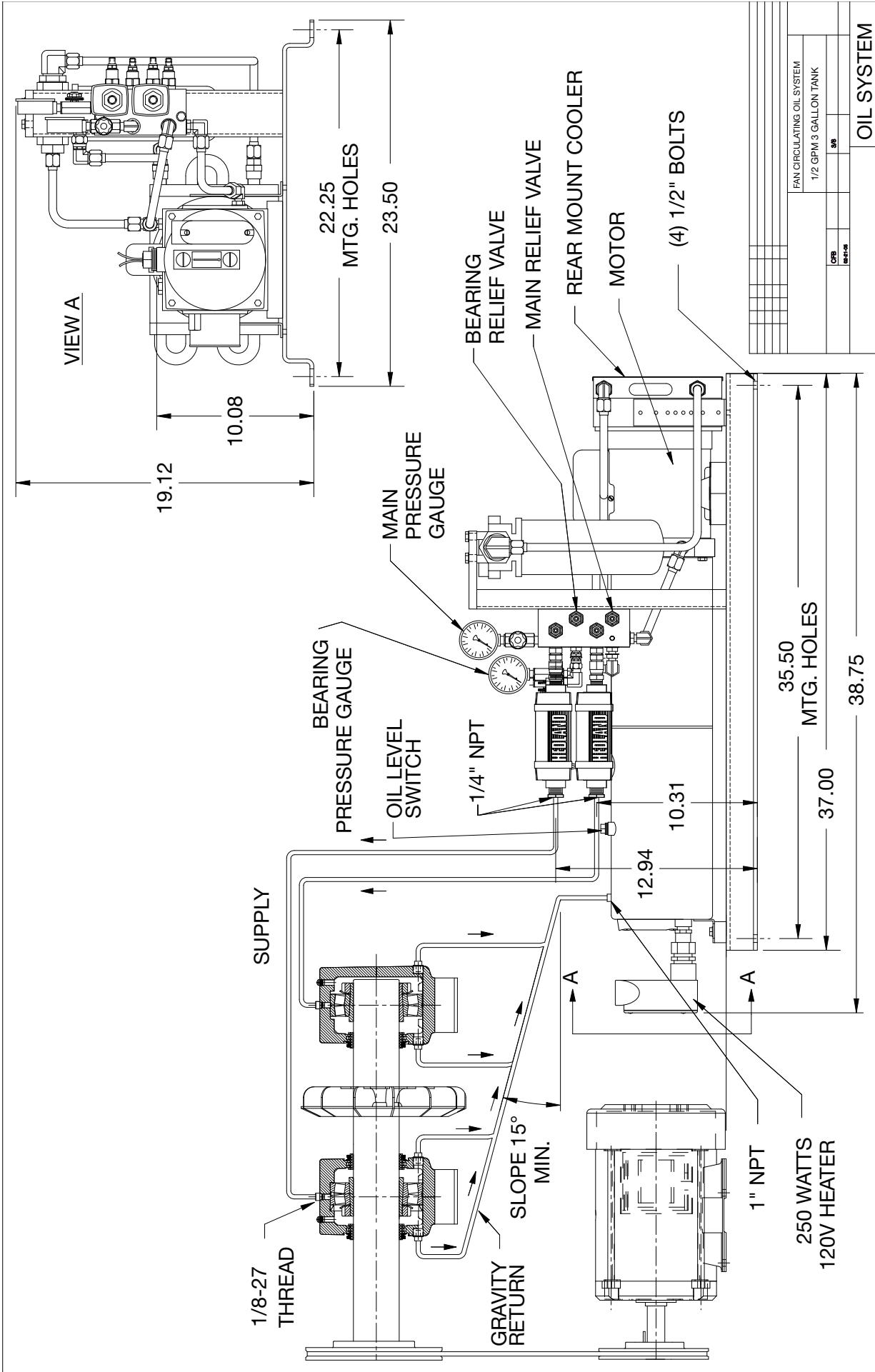

REPLACEMENT FILTER PART NO. 056728
 ELECTRIC MOTOR: 1/2 HP SINGLE PHASE
 115 VOLTS AC - 1725 RPM
 PLUMBING SCHEMATIC: SEE SHEET 2
 INSTRUCTION MANUAL - CONTACT DODGE

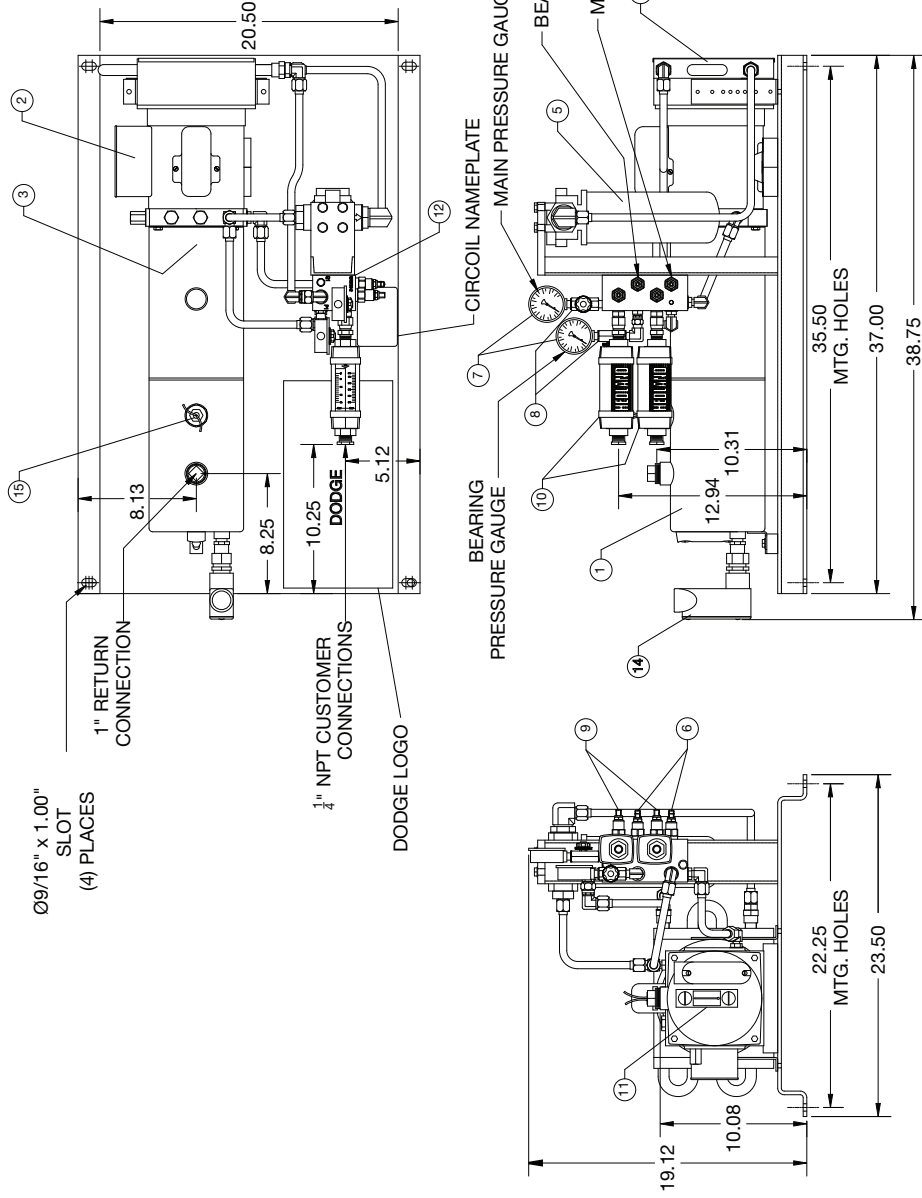

1/2 GPM COOL LUBE SYSTEM - SINGLE PHASE

ORDER NO.	APPROVED BY	DIST
CUSTOMER ORDER NO.	DATE	DAV
BALDOR • DODGE®	DR. BY	MCC
	CHK BY	DATE 02/02/07
	APPD. BY	IMV
		DRAWING NO. 058530-1

APPROVAL

MATERIALS	
MARK QTY.	DESCRIPTION
1	3 GALLON RESERVOIR
1	ELECTRIC MOTOR
1	GEAR PUMP
1	HEAT EXCHANGER
1	FILTER
2	RELIEF VALVE
2	PRESSURE GAUGE (0-400 PSI)
2	NEEDLE VALVE
2	FLOW METER
1	LEVEL GAUGE
1	MANIFOLD
1	SKID
1	250W HEATER
1	LEVEL SWITCH
1	DODGE LOGO
1	DODGE CIRCOIL NAMEPLATE

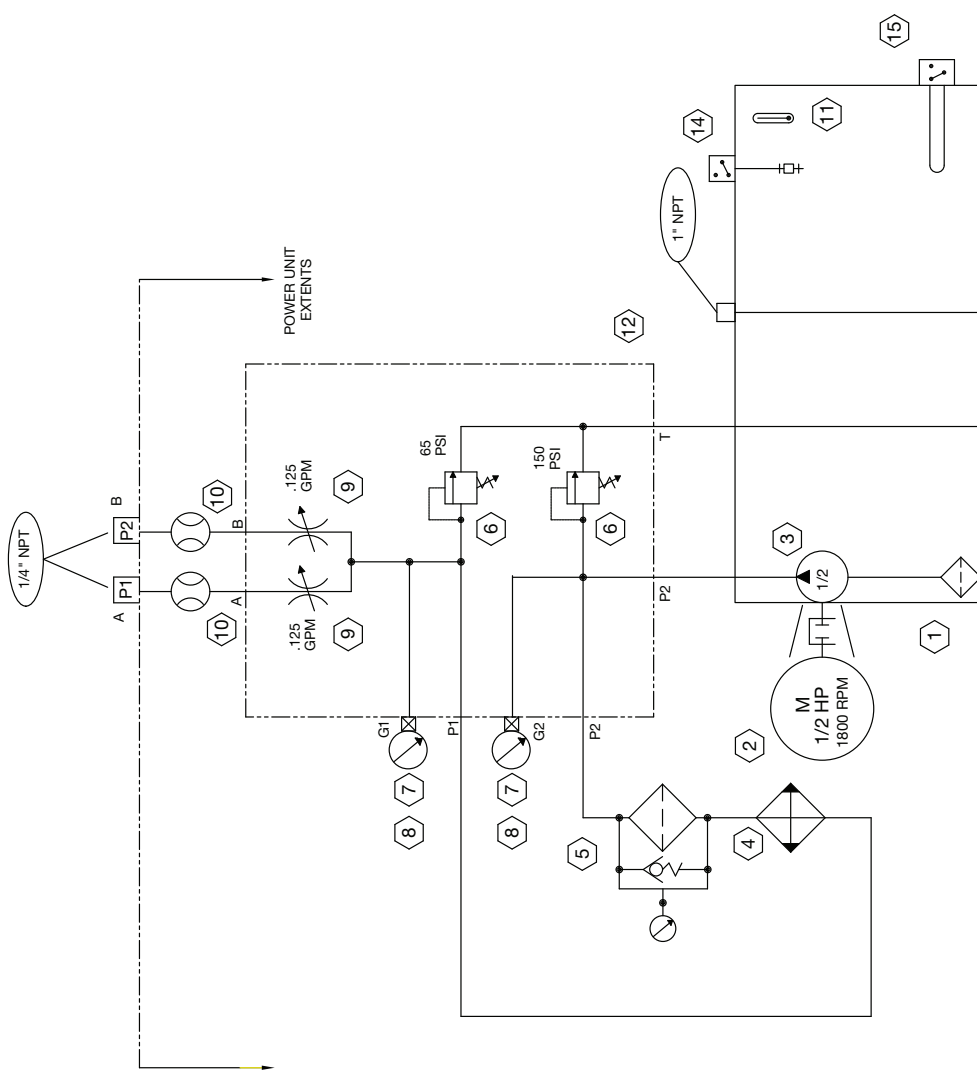

REPLACEMENT FILTER PART NO. 056728
 ELECTRIC MOTOR: 1/2 HP SINGLE PHASE
 115 VOLTS AC - 1725 RPM
 INSTRUCTION MANUAL - CONTACT DODGE

1/2 GPM COOL LUBE SYSTEM PLUMBING SCHEMATIC - SINGLE PHASE

ORDER NO.	APPROVED BY	DATE	DIST.
CUSTOMER ORDER NO.	DATE	MCC	DAV
	DR. BY	DATE	DRAWING NO.
	CK. BY	02/02/07	058530-2
	APP. BY	IMW	

APPROVAL

REPLACEMENT FILTER PART NO. 056728

ELECTRIC MOTOR: 1 HP THREE PHASE
 460 VOLTS AC (60HZ) - 1750 RPM
 400 VOLTS AC (50HZ) - 1450 RPM

PLUMBING SCHEMATIC: SEE SHEET 2
 INSTRUCTION MANUAL - CONTACT DODGE

Ø9/16" X 1.00"
 SLOT
 (4) PLACES

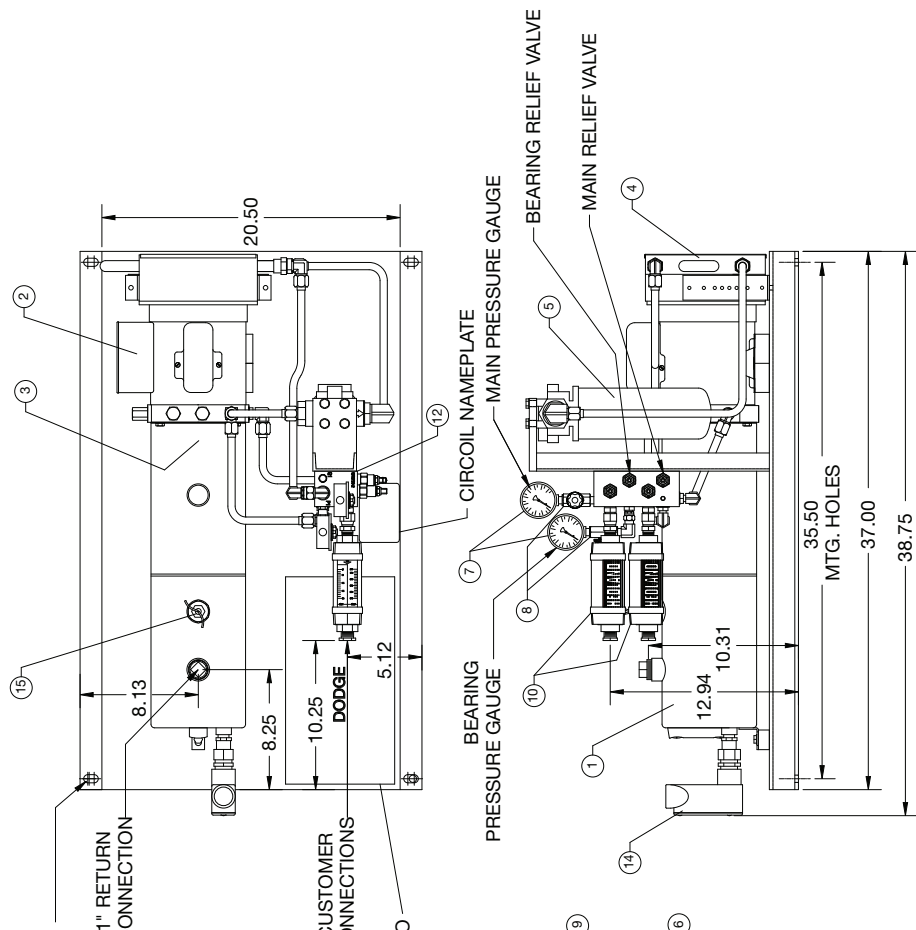

DODGE ORDER # -

ITEM - QUANTITY -

PART NUMBER - 067669

CUSTOMER NAME -

CUST. ORDER # -

PRODUCT SIZE - 0.5 GPM @ 60HZ
 0.4 GPM @ 50HZ

LINER TYPE -

BABBITT TYPE -

CUST. APPROVAL BY -

APPROVAL DATE -

APPROVAL DRAWING

COOL LUBE - 3 PHASE 60 HZ/50HZ



DR BY: MCG DATE: 02/02/07
 CK BY: DATE: 02/02/07
 AP BY: MW DATE: 02/02/07
 DRAWING NO. 067669-1

REV	DFT	DATE	CHK	CHANGE

MATERIALS

MARK QTY.	DESCRIPTION
1	3 GALLON RESERVOIR
1	ELECTRIC MOTOR
1	GEAR PUMP
1	HEAT EXCHANGER
1	FILTER
2	RELIEF VALVE
2	PRESSURE GAUGE (0-400 PSI)
2	GAUGE SNUBBER
2	NEEDLE VALVE
2	FLOW METER
1	LEVEL GAUGE
1	MANIFOLD
1	SKID
1	250W HEATER
1	LEVEL SWITCH
1	DODGE LOGO
1	DODGE CIRCOIL NAMEPLATE

REPLACEMENT FILTER PART NO. 056728
 ELECTRIC MOTOR: 1 HP THREE PHASE
 460 VOLTS AC (60HZ) - 1750 RPM
 400 VOLTS AC (50HZ) - 1450 RPM

INSTRUCTION MANUAL - CONTACT DODGE

DODGE ORDER # -
 ITEM - QUANTITY -
 PART NUMBER - 067669

CUSTOMER NAME -
 CUST. ORDER # -
 PRODUCT SIZE - 0.5 GPM @ 60HZ
 0.4 GPM @ 50HZ
 LINER TYPE -
 BABBITT TYPE -
 CUST. APPROVAL BY -
 APPROVAL DATE -

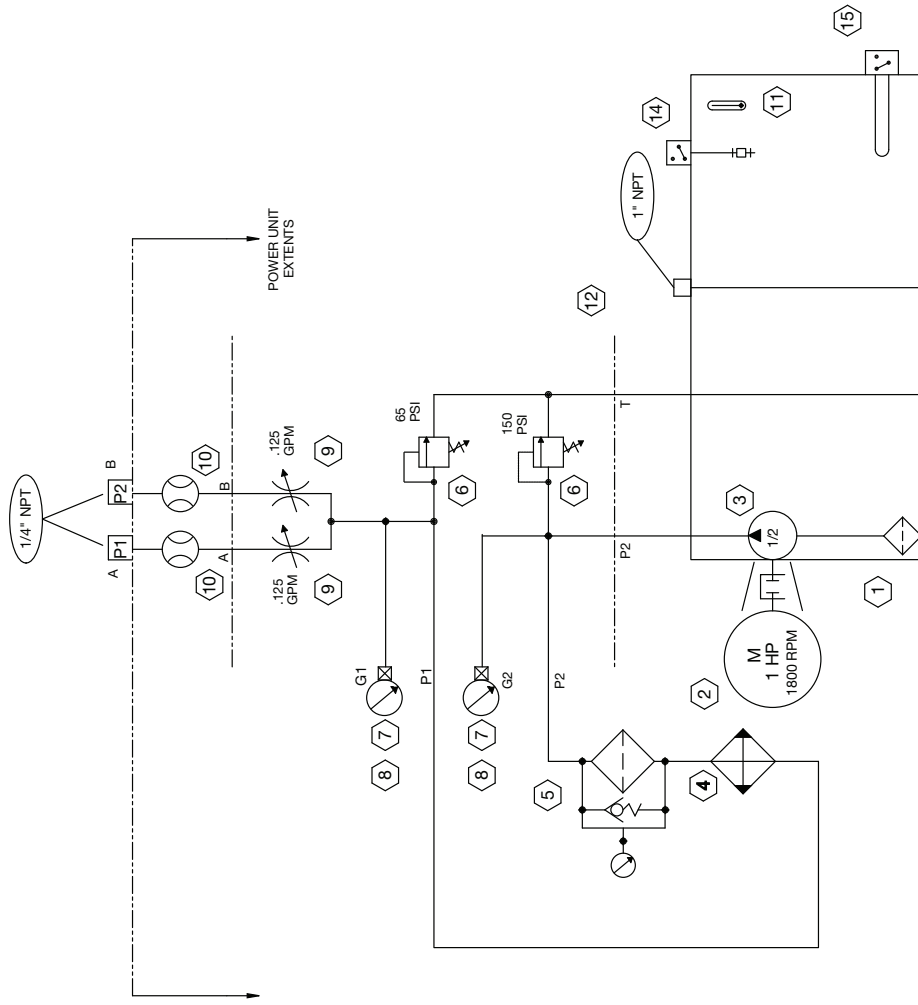

APPROVAL DRAWING

COOL LUBE SYSTEM PLUMBING SCHEMATIC - 3 PHASE



DR. BY: MCC
 CK. BY: MW
 DATE: 2/2/07
 DRAWING NO. 067669-2

REV	DFT	DATE	CHK	CHANGE



World Headquarters

P.O. Box 2400, Fort Smith, AR 72902-2400 U.S.A., Ph: (1) 479.646.4711, Fax (1) 479.648.5792, International Fax (1) 479.648.5895

Dodge Product Support

6040 Ponders Court, Greenville, SC 29615-4617 U.S.A., Ph: (1) 864.297.4800, Fax: (1) 864.281.2433

www.baldor.com

© Baldor Electric Company
MN3008



All Rights Reserved. Printed in USA.
3/10 PRINTSHOP 50