

# Installation Manual for Dodge® TORQUE-ARM® Speed Reducer

## TA1M thru TA7M Motor Mounts TA3ML thru TA7ML (Long Series) Motor Mounts Sizes TXT1 thru TXT7

### INSTALLATION

**WARNING:** To ensure that drive is not unexpectedly started, turn off and lock out or tag power source before proceeding. Remove all external loads from drive before removing or servicing drive or accessories. Failure to observe these precautions could result in bodily injury.

**NOTE** Refer to photo for position of all parts before installation.

**NOTE:** Guards have been removed for photographic purposes.

1. Remove the two or three bolts required for mounting the TAM and TAML Motor Mounts from the reducer housing. Install the front and rear supports (2) using the new reducer bolts (1) supplied with the motor mount. Make sure support flanges face output side of reducer. Tighten bolts securely.
2. Mount bottom plate (3) on supports with bolts supplied. Insert bolts (7) from top through slotted holes. Add flatwasher, lockwasher, and nut. Hand tighten.
3. Thread two nuts (6) on each threaded stud (5) leaving approximately 1" of stud protruding at one end. Insert threaded stud with 1" of threads through corner holes of bottom plate, thread a hex nut (6) on the stud and tighten securely.
4. Slide top plate (4) over the threaded stud, making sure center handling hole is positioned opposite input side of reducer. Thread a hex nut (6) on the studs and tighten securely.
5. Locate the proper position for the motor and bolt it to the top plate. Tighten bolts securely.
6. Install motor sheave and reducer sheave as close to motor and reducer housings as possible. Accurately align the motor and reducer sheave by sliding bottom plate in relation to supports. Tighten bolts (7) securely.
7. Install V-belts and tension belts by alternately adjusting nuts (6) on the threaded studs (jackscrews). Make certain that all bolts are securely tightened, the V-belt drive is properly aligned and an appropriate belt guard is installed before operating the drive.

**WARNING:** Because of the possible danger to persons(s) or property from accidents which may result from the improper use of products, it is important that correct procedures be followed. Products must be used in accordance with the engineering information specified in the catalog. Proper installation, maintenance and operation procedures must be observed. The instructions in the instruction manuals must be followed. Inspections should be made as necessary to assure safe operation under prevailing conditions. Proper guards and other suitable safety devices or procedures as may be desirable or as may be specified in safety codes should be provided, and are neither provided by Baldor Electric Company nor are the responsibility of Baldor Electric Company. This unit and its associated equipment must be installed, adjusted and maintained by qualified personnel who are familiar with the construction and operation of all equipment in the system and the potential hazards involved. When risk to persons or property may be involved, a holding device must be an integral part of the driven equipment beyond the speed reducer output shaft.

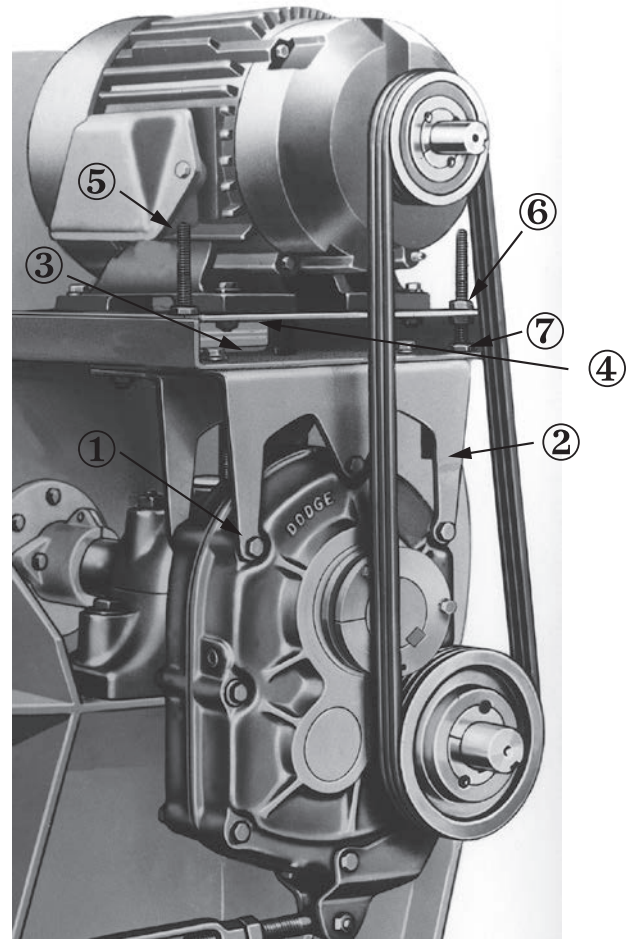

Figure 1 - Motor Mounting Positions

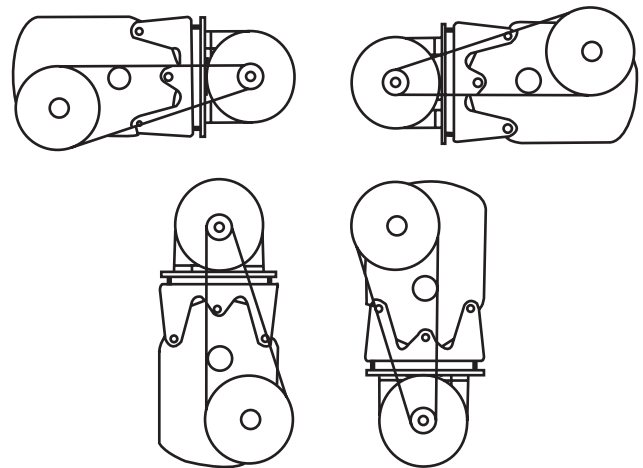
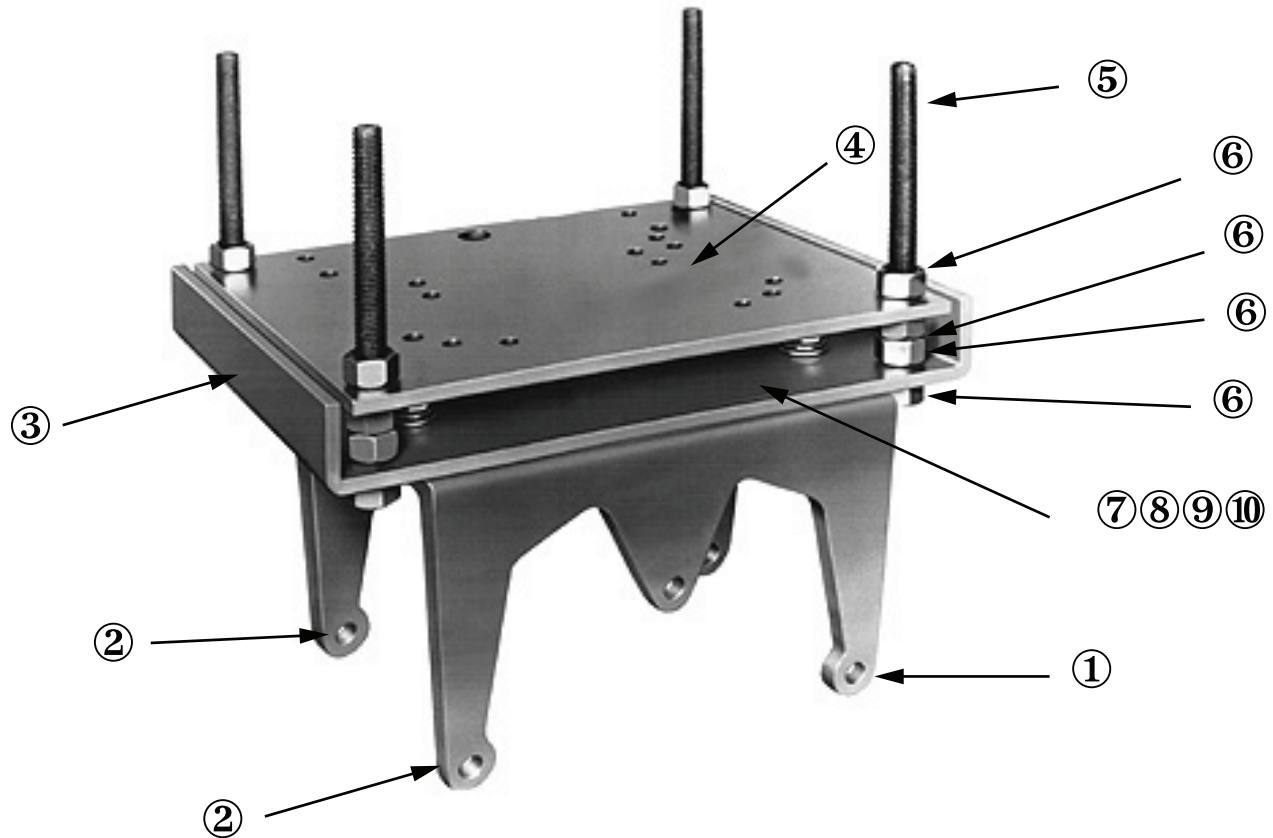

Figure 2 - Mount Motor at any Point Around Drive Shaft

**BALDOR • DODGE®**



**REPLACEMENT PARTS FOR TA3ML THRU TA7ML MOTOR MOUNTS**

REFERENCE NUMBER	NAME OF PART	NUMBER REQUIRED	TA3ML PART NO	TA4ML PART NO	TA5ML PART NO	TA6ML PART NO.	TA7ML PART NO.
1	Housing Bolts	3	411732	411733	411734	411735	411736
2	Support	2	243386	244354	245386	246386	247386
3	Bottom Plate	1	351180	354183	354183	356213	356267
4	Top Plate	1	351181	354184	354184	356214	356268
5	Threaded Stud	4	408004	408003	408003	408003	408591
6	Hex Nut	16	407122	407279	407279	407279	407214
7	Bolt	4	411102	411102	411102	411102 ①	411102 ①
8	Washer	4	419078	419078	419078	419078 ①	419078 ①
9	Lockwasher	4	419019	419019	419019	419019 ①	419019 ①
10	Nut	4	407282	407282	407282	407282	407282

① 6 REQUIRED ON TA6ML & TA7ML

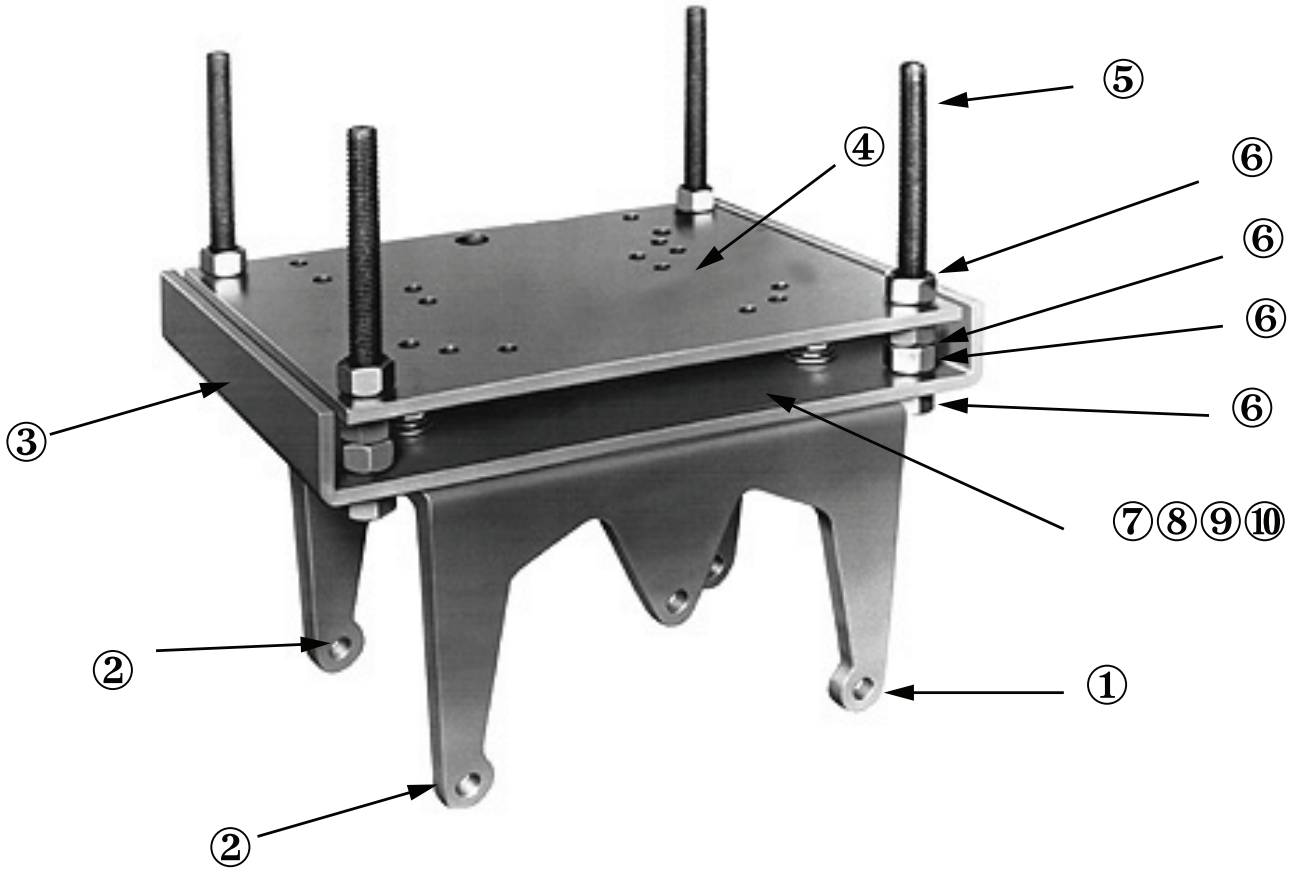

**REPLACEMENT PARTS FOR TA1M THRU TA7M MOTOR MOUNTS**

REFERENCE NUMBER	NAME OF PART	NUMBER REQUIRED	TA1M PART NO	TA3M PART NO	TA4M PART NO	TA5M PART NO.	TA6M PART NO.	TA7M PART NO.
1	Housing Bolts	① 3	411731	411732	411733	411734	411735	411736
2	Support	2	241385	243385	244355	245385	246385	247385
3	Bottom Plate	1	351180	351180	354183	354183	356213	356287
4	Top Plate	1	351181	351181	354184	354184	356214	356268
5	Threaded Stud	4	408004	408004	408003	408003	408003	408591
6	Hex Nut	16	407122	407122	407279	407279	407279	407214
7	Bolt	4	411102	411102	411102	411102	411102 ②	411102 ②
8	Washer	4	419078	419078	419078	419078	419078 ②	419078 ②
9	Lockwasher	4	419019	419019	419019	419019	419019 ②	419019 ②
10	Nut	4	407282	407282	407282	407282	407282	407282

① 2 REQUIRED ON TA1M

② 6 REQUIRED ON TA6ML & TA7ML



P.O. Box 2400, Fort Smith, AR 72902-2400 U.S.A., Ph: (1) 479.646.4711, Fax (1) 479.648.5792, International Fax (1) 479.648.5895

**Dodge Product Support**

6040 Ponders Court, Greenville, SC 29615-4617 U.S.A., Ph: (1) 864.297.4800, Fax: (1) 864.281.2433

[www.baldor.com](http://www.baldor.com)