

TECHNICAL NOTE

UPGRADED EXTREME PAINT

Built for more extreme environments

Layer 1	Layer 2	Layer 3
3.2 mils Zinc Primer	5.6 mils Primer	5.2 mils Topcoat

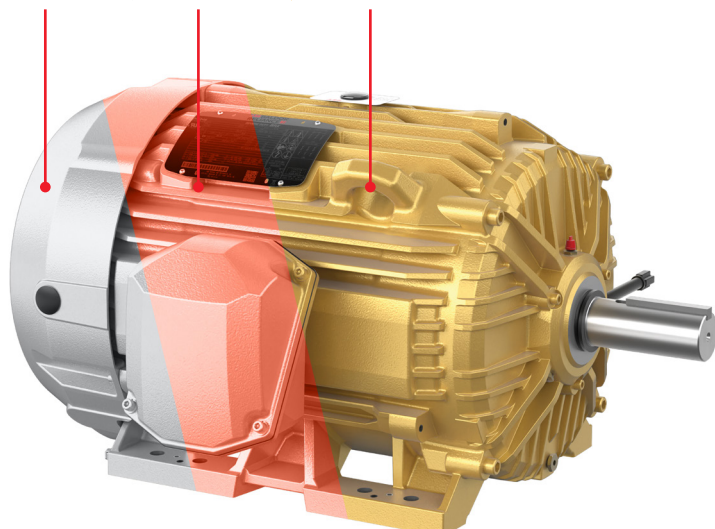

 High Zinc Dust Epoxy Primer	 Polyurethane Primer	 Polyurethane Topcoat
---	---	--

When equipment operates in harsh, corrosive environments, surface protection matters.

ABB's upgraded CX paint system increases the total coating build and adds more rigorous performance validation compared with the prior C5-M paint system, now available for ABB Baldor-Reliance® cast iron motors.

C5-M PAINT SYSTEM

NEW CX PAINT SYSTEM FOR CAST IRON MOTORS

Layer	DFT (mils)	Description	# of Coats
1	3.0 mils	Zinc rich primer	1
2	7.2 mils	Epoxy polyamide intermediate	1
3	2.0 mils	Polyurethane topcoat	1

Layer	DFT (mils)	Description	# of Coats
1	3.2 mils	High zinc dust content epoxy primer	1
2	5.6 mils	Polyurethane primer	2
3	2.0 mils	Polyurethane topcoat	2

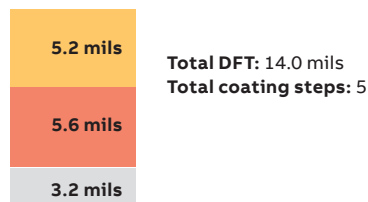
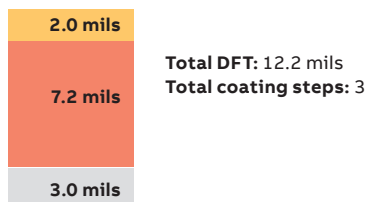

UPGRADING TO CX PAINT SYSTEM

Proven through extreme exposure

WHY CX? WHAT DOES THIS MEAN TO OUR CUSTOMERS?



Improved corrosion protection

Designed for severe environments where moisture, salt, chemicals and weather exposure can shorten equipment life.



Greater coating durability

Higher total coating build and additional coating steps support longer-lasting surface protection.



More rigorous validation

Testing combines salt spray, UV/condensation and low-temperature exposure for a stronger durability story.



Confidence in harsh-duty service

Supports coastal, marine, offshore and highly corrosive industrial environments.

The CX system has undergone 25 cycles of cyclic ageing per ISO 12944-9. Each cycle combines UV and condensation exposure, salt spray exposure and low-temperature exposure to simulate changing conditions found in severe service environments.

Each CX test cycle includes	Total after 25 cycles	Results
<ul style="list-style-type: none"> 72 hours UV and condensation 72 hours of salt spray exposure 24 hours at -20C low temperature 	<ul style="list-style-type: none"> 1,800 hours UV and condensation 1,800 hours salt spray 4,200 total hours cyclic ageing 	<ul style="list-style-type: none"> 0 blistering 0 rusting 0 cracking 0 flaking

CX validation

1,800 hours salt spray + 1,800 hours UV/condensation + low-temperature exposure

Prior C5-M validation

720 hours salt fog + 480 hours condensation testing

From C5-M to CX: a stronger paint system for tougher environments