

Product identifier

FMH2A03TR-EN23

FMH | FMH = MicroFlex family
2 = 115-230VAC (1Ø or 3Ø) AC input
A03 = 3A, A06 = 6A, A09 = 9A cont. output
T = Built in mains power supply
R = Requires external regeneration resistor*
E = Encoder feedback, R = Resolver feedback
N = No options specified
2 = RS232 serial port, 4 = RS485 serial port
3 = Customer supplied 24VDC

* Regeneration resistors:
 If the application requires a regeneration resistor, it must have a resistance of at least 39Ω and inductance of less than 100μH. Baldor parts RG56 (44W) or RG39 (100W) are recommended.

X1 - Power, single phase supply

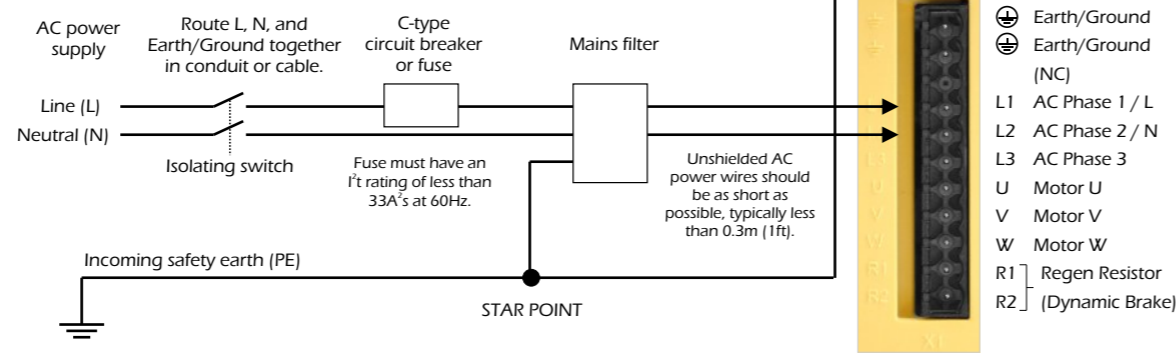

X1 - Power, three phase supply

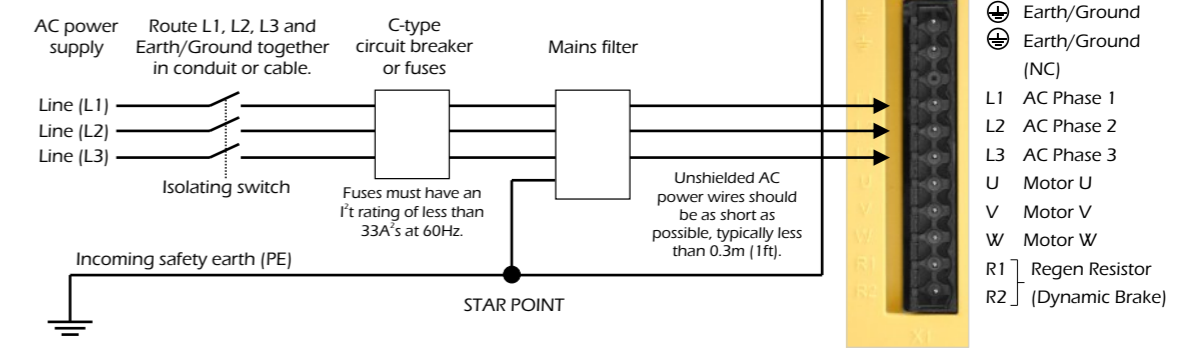

Recommended power filters

Control continuous current rating	1Ø AC power	3Ø AC power	24VDC control supply
3A	FI0015A00†	FI0018A00	FI0014A00
6A	FI0015A02†	FI0018A00	(all models)
9A	FI0029A00	FI0018A03	

IMPORTANT! See installation manual MN1919 (included on the supplied CD) for additional information about connecting filters. Specified filters provide compliance with EN61000-6-3 (Class B).

†Alternatively, foot-mount filter FI0029A00 may be used. This filter is specially designed for use with any single-phase MicroFlex.

Cooling requirements

Control continuous current rating	Air flow velocity
3A	No additional cooling required.
6A	1.0 m/s (3.3 ft/s) or greater.
9A	2.5 m/s (8.2 ft/s) or greater.

IMPORTANT! It is essential that the 6A and 9A models receive additional cooling, as stated in the installation manual. Air should originate from below the MicroFlex, passing parallel to the heatsink. Optional fan tray FAN001-024 provides sufficient cooling for all models.

X6 - RS232/RS485

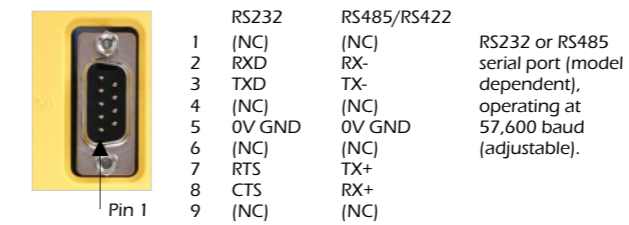

Status LED

- Green: AC power OK, drive enabled, normal operation.
- Red: AC power OK, drive not enabled, no errors.
- / ● Green/Red alternating: AC power not present, no errors.

- Green flashing: Firmware download in progress.
- Red flashing: An error has occurred. The number of flashes (followed by a pause) indicates which error has occurred:

Error code (flashes)	Meaning
1	DC bus overvoltage trip
2	IPM (integrated power module) trip
3	Overcurrent trip
4	Overspeed trip
5	Feedback trip
6	Motor overload (I ^t) trip
7	Overtemperature trip
8	Drive overload (It) trip
9	Following error trip
10	Error input triggered
11	Phase search error
12	All other errors, including: Internal supply error, encoder supply error, parameter restore failure,

Recommended system wiring

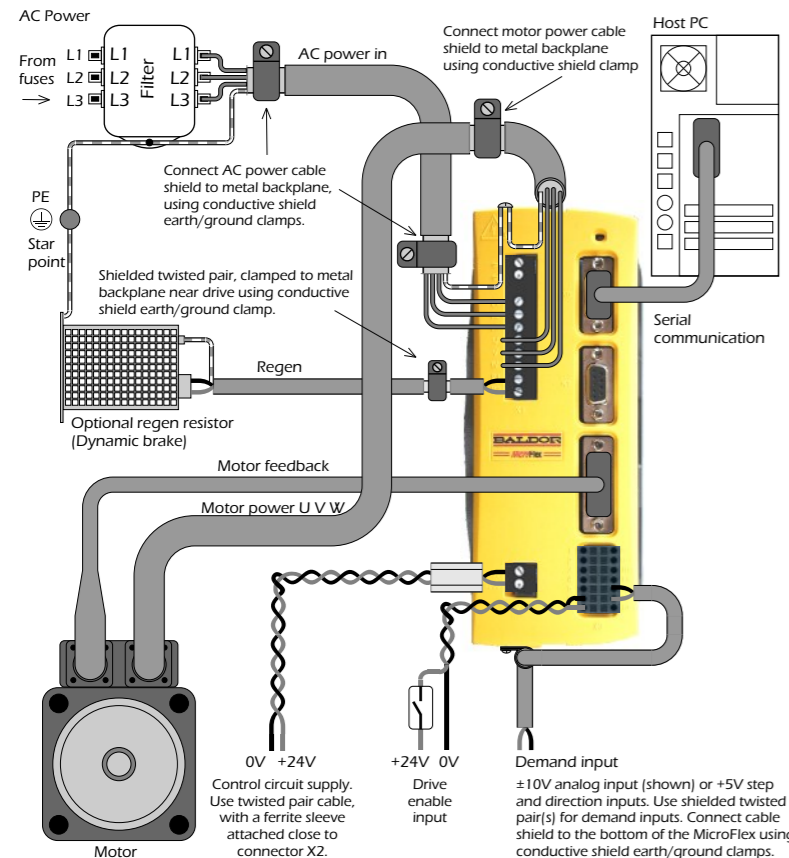

X1 - AC input & motor power

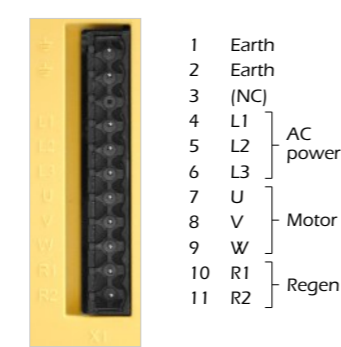

X2 - 24V control circuit input



A 24VDC supply must be provided to power the controlling electronics.



www.supportme.net

LT0188A03

The information in this document is subject to change without notice. Baldor assumes no responsibility for any errors that may appear in this document.

X3 - Input / Output

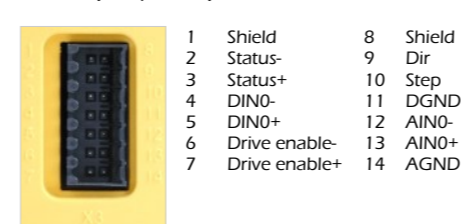

- * Drive enable Opto-isolated 24V input. Must be connected to allow drive to operate.
- * DIN0 Opto-isolated 24V input. Can be configured as a reset, error, stop or phase search input.
- * Step & Dir +5V single-ended step and direction inputs, used as the position reference.
- * AIN0 ±10V differential input, used as the speed or torque reference.
- * Status Opto-isolated status/error output, indicates enabled/disabled status of drive. Current sourced from pin 3 is output on pin2.

X8 - Feedback in - encoder

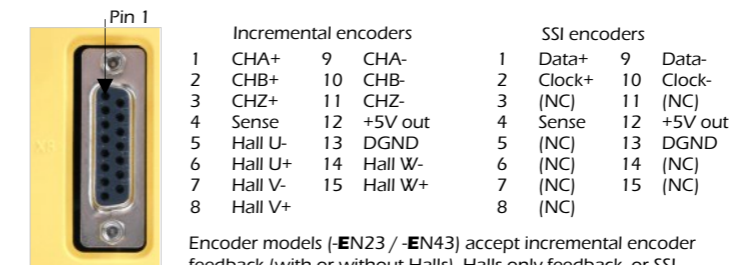

Encoder models (-EN23 / -EN43) accept incremental encoder feedback (with or without Halls), Halls-only feedback, or SSI encoder feedback. Pin 12 provides a +5V, 200mA supply for encoders requiring power.

X8 - Feedback in - resolver

