



DC SERVO DRIVE

SERIES LD

DC Servo Control

Installation & Operating Manual

Table of Contents

Section 1	
General Information	1-1
Year 2000 Compliance	1-1
Limited Warranty	1-1
Safety Notice	1-2
Introduction	1-4
Features	1-5
Model Information	1-6
Functional Description	1-7
Specifications	1-8
General Description	1-10
Servo Control Card	1-10
Chassis Assembly	1-10
Logic Power Supply	1-10
Bus Power Supply	1-10
Overvoltage Protector	1-10
Adjustments, Testpoints, and Indicators	1-10
Adjustments	1-11
Tools	1-14
Section 2	
Installation	2-1
Receiving & Inspection	2-1
Location Considerations	2-1
Installing the Servo Control Card	2-1
Mount the Chassis	2-2
General Wiring Considerations	2-3
Power Wiring	2-3
Grounding	2-3
Signal Wiring	2-4
Electrical Noise Suppression	2-4
Wiring Instructions	2-4
Power Wiring	2-4
Signal Wiring	2-5
Input Wiring Connections	2-6
Optional Input Signal Wiring	2-6
Section 3	
Start-up	3-1
Overview	3-1
Initial Potentiometer Settings	3-1
Start-up (Power On)	3-1
Adjustment Procedure	3-2

Section 4	
Troubleshooting and Maintenance	4-1
Overview	4-1
Initial Checks	4-1
Resetting the Servo Control	4-1
Maintenance	4-3
Servo Control Card Replacement	4-3
Section 5	
Special Functions	5-1
Current (Torque) Mode	5-1
Emergency Stop	5-2
Appendix A	A-1
Condensed Installation Instructions	A-1
Appendix B	B-1
Jumper and Personality Module Settings	B-1
Personality Module Current Settings	B-1
Peak and Continuous Current Levels	B-1
Record of “Set Up” Configuration	B-2

Section 1 General Information

Year 2000 Compliance

The motor control products listed below are manufactured or offered for sale by Baldor Electric and are certified to be year 2000 compliant.

DC Motor Controls: Series BC100/200, BC19H, BC20H, LD, TSD, UM, UMH.

AC Motor Controls: Series ID10, ID1100, ID15H, ID15J, ID15V, ZD17H, ZD18H, ID21H, ZD22H, SD23H, ZD24M, ZD25M, SD26M, BSC, DBSC, BTS, SBTS.

Position Controllers: PMC, SmartMove, NextMove.

Furthermore, year 2000 compliance means that the product will:

- Not use dates or perform any date processing.
- Date information is irrelevant to proper operation; and
- There are no problems or issues to address to ensure continued and proper operation of the product listed due to changes in century dates.

Limited Warranty

For a period of two (2) years from the date of original purchase, BALDOR will repair or replace without charge controls and accessories which our examination proves to be defective in material or workmanship. This warranty is valid if the unit has not been tampered with by unauthorized persons, misused, abused, or improperly installed and has been used in accordance with the instructions and/or ratings supplied. This warranty is in lieu of any other warranty or guarantee expressed or implied. BALDOR shall not be held responsible for any expense (including installation and removal), inconvenience, or consequential damage, including injury to any person or property caused by items of our manufacture or sale. (Some states do not allow exclusion or limitation of incidental or consequential damages, so the above exclusion may not apply.) In any event, BALDOR's total liability, under all circumstances, shall not exceed the full purchase price of the control. Claims for purchase price refunds, repairs, or replacements must be referred to BALDOR with all pertinent data as to the defect, the date purchased, the task performed by the control, and the problem encountered. No liability is assumed for expendable items such as fuses.

Goods may be returned only with written notification including a BALDOR Return Authorization Number and any return shipments must be prepaid.

Safety Notice:

This equipment contains high voltages. Electrical shock can cause serious or fatal injury. Only qualified personnel should attempt the start-up procedure or troubleshoot this equipment.

This equipment may be connected to other machines that have rotating parts or parts that are driven by this equipment. Improper use can cause serious or fatal injury. Only qualified personnel should attempt the start-up procedure or troubleshoot this equipment.

PRECAUTIONS:

- ⚠ WARNING:** Do not touch any circuit board, power device or electrical connection before you first ensure that power has been disconnected and there is no high voltage present from this equipment or other equipment to which it is connected. Electrical shock can cause serious or fatal injury. Only qualified personnel should attempt the start-up procedure or troubleshoot this equipment.
- ⚠ WARNING:** Be sure that you are completely familiar with the safe operation of this equipment. This equipment may be connected to other machines that have rotating parts or parts that are controlled by this equipment. Improper use can cause serious or fatal injury. Only qualified personnel should attempt the start-up procedure or troubleshoot this equipment.
- ⚠ WARNING:** Be sure all wiring complies with the National Electrical Code and all regional and local codes. Improper wiring may result in unsafe conditions.
- ⚠ WARNING:** Be sure the system is properly grounded before applying power. Do not apply AC power before you ensure that grounds are connected. Electrical shock can cause serious or fatal injury.
- ⚠ WARNING:** Before servicing this control, allow at least five (5) minutes after AC power is disconnected to allow capacitors to discharge. Electrical shock can cause serious or fatal injury.
- ⚠ WARNING:** Improper operation of control may cause violent motion of the motor shaft and driven equipment. Be certain that unexpected motor shaft movement will not cause injury to personnel or damage to equipment. Peak torque of several times the rated motor torque can occur during control failure.
- ⚠ WARNING:** Motor circuit may have high voltage present whenever AC power is applied, even when motor is not rotating. Electrical shock can cause serious or fatal injury.
- ⚠ WARNING:** A DB Resistor may generate enough heat to ignite combustible materials. To avoid fire hazard, keep all combustible materials and flammable vapors away from brake resistors.

Continued on next page.

-
- ⚠ Caution:** To prevent equipment damage, be certain that the electrical service is not capable of delivering more than the maximum line short circuit current amperes listed for the control rating.
 - ⚠ Caution:** To prevent equipment damage, be certain that the input power has correctly sized protective devices installed as well as a power disconnect.
 - ⚠ Caution:** Avoid locating control immediately above or beside heat generating equipment, or directly below water or steam pipes.
 - ⚠ Caution:** Avoid locating control in the vicinity of corrosive substances or vapors, metal particles and dust.
 - ⚠ Caution:** The X and Y Axis motors may tend to run away, out of control, if the tach wires are reversed. If the axis moves in the wrong direction, the motor wires are reversed. If, however, reversing the leads doesn't stop a runaway motor, make sure the T (Tachometer) potentiometer is not full counterclockwise.

Introduction

The Baldor "LD" Series Servo Control (see Figure 1-1) is a multi axis pulse width modulated (PWM), high performance servo control designed to be used with DC brush type permanent magnet servomotors. This transistorized servo control is a key component in motion control applications, providing not only converted DC power to the motor, but also precisely controlling current and velocity at the motor. Its compact design requires very little enclosure space, while its modular configuration makes servicing easy.

The "LD" Series can be used with many types of position controllers due to its standardized \pm VDC signal input.

Figure 1-1 "LD" Series Servo Control (2 Axis Package)

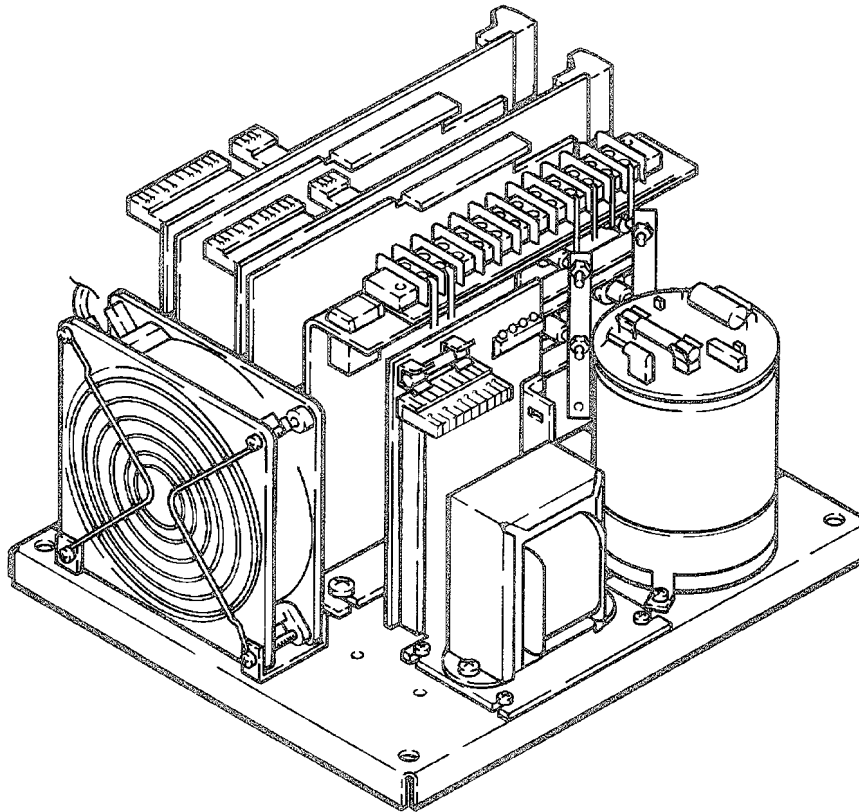

Features

The Baldor "LD" Series switching concept enables the user to operate with the highest possible bandwidth with reduced switching losses, ripple current, EMI and RFI. Servo Control cards are field replaceable.

Note: "LD" and "UM" series cards are NOT interchangeable.

The "LD" chassis and Servo Control card combination provides protection features and status indicators including:

- Voltage Error (VE)
- Excess Current (EC)
- Thermal Protection (EC)
- Ground Fault (GF)
- Surge Current (SC) and Short Circuit Protection
- Logic Voltage Status (MV, PV) or (-15V, +15V)
- Bus Voltage Status (PB) or (BUS)
- AC Input Voltage Status (AC)

Other standard features include:

- 20 kHz "Inaudible" Switching
- Test Points – to aid during set up
- Jumper Settings – allow easy tailoring for specific applications
- "Personality Module" – for custom current settings
- Decoupled current sense – for monitoring current (absolute or actual value)
- EC Latch or Foldback – selectable response to overcurrent condition
- Left Limit – Overtravel Limit
- Right Limit – Overtravel Limit
- Interlock – used to shut down output to motor
- External reset line
- Push button reset
- Phoenix style detachable screw terminals

Each Servo Control can be configured for:

- Velocity mode operation with tachometer
- Current mode operation
- Differential or single ended signal inputs

Model Information

Model descriptors that describe key parameters of each unit specify the "LD" Series Servo Control and Chassis. The "LD" Series Servo Control cards can be configured with chassis to support up to four (4) axes at 160 VDC.

Figure 1-2 Identification

Complete Assembly:

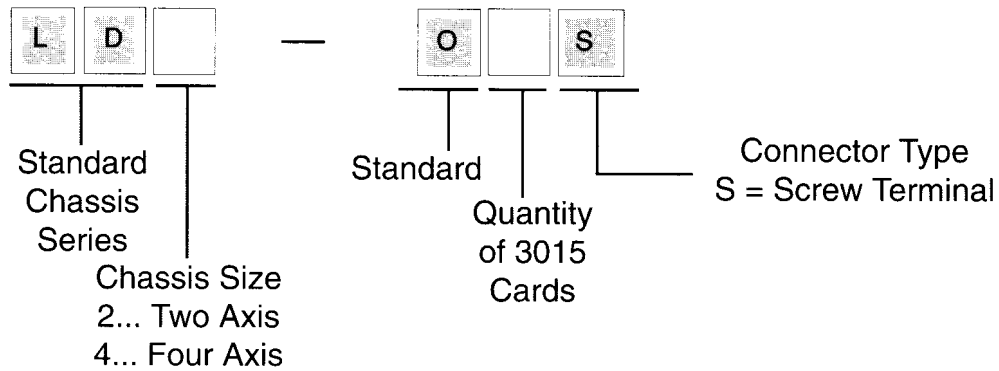

Chassis & Power Supply:

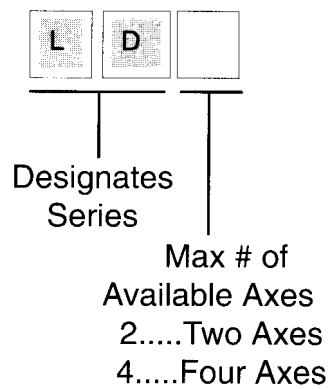

Servo Control Card:

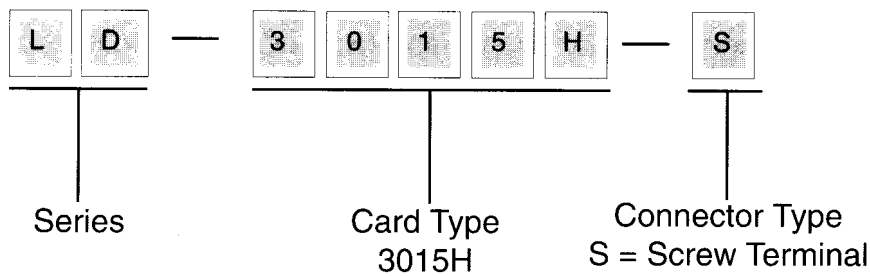

Functional Description

The “LD” Servo Control consists of (1) a power supply, (2) a velocity control amplifier and (3) fault logic circuitry. The functional concepts are detailed below.

Power Supply

The power supply of a PWM bridge normally acts as a low output impedance voltage source. However, if an analog signal representing motor current is applied to the front end of the amplifier together with a current command, the impedance of the PWM bridge then becomes high. These high impedance bridges exhibit a unique characteristic referred to as current sourcing. That is, motor current and therefore motor torque becomes proportional to commanded input current.

Current Sense Coupler

The current sense coupler within the power amplifier serves as the current loop feedback mechanism. The unit isolates the high voltage motor signal from the low level control circuitry.

Switching Configuration

The power amplifier contains a transistor bridge consisting of 2 limbs each containing 2 main switches. These switches enable a limb output to be connected alternately from the minus bus to the plus bus. Both limb output signals or motor lines are normally zero with respect to the minus bus. However, if current is commanded as described above, the average voltage on only one of the limbs will increase while the other limb remains connected to the minus bus. This switching configuration is referred to as the lower circulation method.

Velocity Control Amplifier (VCA)

The high gain front–end velocity control amplifier accepts a speed command (Signal) and a tachometer voltage (Tach) through the input connector. The VCA clamped error signal (C adjustment) is applied to the power amplifier as a current command.

Excess Current Limit

The long–term current clamp senses motor current and responds to overload conditions beyond rated output. If the comparator is tripped, it disables the drive, lights the Excess Current (EC) indicator and pulls the interlock line “low” (if P4 is in latch position).

Surge Current Sensor

The surge current sensor pulls the interlock line low internally if the peak output current is exceeded. Once stopped, the drive must be cleared by connecting the reset line to common momentarily (reset switch) or by interrupting logic power for 2 seconds.

Overheat Sensor

A thermal switch with significant hysteresis attached to the heatsink sets the EC (Excess Current) latch if the heatsink temperature exceeds a preset level. The latch operates the EC fault indicator. The fault condition is cleared after the heatsink temperature returns to normal and a reset is given.

Left Limit, Right Limit

Limit switches are typically mounted on machinery to restrict the load from moving into catastrophic over–travel conditions. Limit switch polarity of the voltage on this line is the same as that on the signal pin of the input connector. The motor is wired such that movement produces a positive voltage on NIML (Non–Inverting Motor Line) with respect to IML (Inverting Motor Line). Therefore, a positive input signal will cause the axis to move in a rightward direction. The limit switch leads are then wired confidently to the appropriate pins of the input connector.

Decoupled Current Sense

The Decoupled Current Sense (DCS) pin is isolated from the high voltage motor lines. Therefore, motor current is evaluated safely by connecting an oscilloscope or voltmeter to the DCS pin of the input connector and common (TP1).

Tachometer Filter

The tachometer filter rejects tachometer commutator noise by reducing the tach path bandwidth so that the high gain velocity control amplifier can be responsive yet reject tach noise.

Specifications

Standard Chassis & Power Supply Assemblies

Output:

	LD2-	LD4-
Rated Bus Voltage (VDC)	160	160
Rated Continuous Current (A)	27	50
Positive Logic 15VDC (A)	1.0	1.0
Negative Logic 15VDC (A)	1.0	1.0

Input:

	LD2-	LD4-
Nominal Bus Input (VAC 50/60Hz)	115	115
Bus Input Range (VAC 50/60Hz)	105-125	105-125
Number of Phases	1	3
Nominal input for Fan & Logic Supply (VAC 50/60Hz)	Prewired	115 (1 phase)

Overvoltage Protection:

	LD2-	LD4-
Continuous Rating (W)	250	500
Peak Rating (W)	4000	8000
Clamp Rating (V)	195	195
Shutdown Point Typical (V)	220	220

General:

	LD2-	LD4-
Operating Temperature (°C)	0-50	0-50
Weight (lbs.)	14	20.6
Footprint (inches)		
Length	9	13
Width	10.5	10.5
Height	7.25	7.25

Notes:

1. An isolation transformer is not required for "LD" controls (115VAC, 1phase).
2. For LD-4, the power requirements cannot be met by 115VAC 1phase input power. It is recommended that a 230VAC input power be used with an isolation transformer to provide 115VAC 3 phase input power for an LD-4.
3. Line power limitations with 1 phase prevents the chassis and drives from delivering full continuous rated output power.

Servo Control Card

Output:

	LD3015HS
Rated Bus Voltage (VDC nominal)	160
Rated Continuous Current (A)	15
Current Limit Adjust (A)	5-15
Peak Current Adjust (A) (maximum time 1.5 seconds)	30
Peak Current Adjust (A)	0-30
Switching Frequency (kHz)	20
Form Factor	1.01
Minimum Inductance (mH)	2.0
Frequency Response (kHz)	2.5

Input:

	LD3015HS
Signal Input (\pm VDC) See note 2.	5 to 15
Drift (μ V/ $^{\circ}$ C)	10
Overall Gain (A/V min)	0-6000

Auxiliary input:s

	LD3015HS
See note 3.	
Impedance (k ohms)	20

Power Requirements:

	LD3015HS
Logic +15VDC (mA)	180
-15VDC (mA)	55
Bus range (VDC)	148-176

General:

	LD3015HS
Weight (lbs.)	1.4
Operating Temperature ($^{\circ}$ C)	0-50

Notes:

1. RMS current limit is a built-in function that turns off or folds back the servo control if the continuous current is exceeded for an extended period of time. The (EC) fault indicator identifies the condition.
2. Input signal (S) can be differential or single ended while the auxiliary (A) and tachometer (T) signals are single ended for all models.
3. The Left Limit, Right Limit and external Reset auxiliary input signals are connected through normally open (NO) contacts while the external status I/O signal is provided through a bi-directional Interlock. The current sense signal (DCS) is provided as an analog representation of current. For information on usage, refer to Section 2.

- General Description** A typical Baldor “LD” Servo Control like that shown in Figure 1-3 can contain from 1 to 4 servo control cards and a chassis assembly. The chassis assembly includes a Logic Power Supply, Bus Power Supply, Overvoltage Protector, Fans and miscellaneous hardware.
- Servo Control Card** The servo control card is a circuit board, which translates bus voltage and velocity information into an output for the servomotor with a defined velocity and direction.
- Chassis Assembly** The chassis assembly provides the mounting plate for the servo control cards as well as the power supplies.
- Logic Power Supply** The logic power supply converts the 115 VAC input to a ± 15 VDC for operating the servo control electronics and provides a fused ground fault protection circuit. Four green status LED’s are also provided to verify the presence of +15 VDC (PV), -15 VDC (MV), AC for fans and logic (AC), and DC Bus voltage (PB or BUS).
- Bus Power Supply** The bus power supply converts the 115 VAC input voltage into a DC voltage, which is controlled within the servo control to power the servomotor.
- Overvoltage Protector** The standard configuration contains an overvoltage protector, which dissipates (shunts) excess bus voltage developed during rapid deceleration to prevent damage to the servo control. The overvoltage protector is fused to protect against catastrophic conditions.
- Adjustments, Testpoints, and Indicators**

The servo control card contains six set-up adjustments and four (4) red fault indicators for flexibility and troubleshooting (see Figure 1-4.) The logic power supply has four green status indicators which when lit show the presence of AC and DC power to the chassis.

Figure 1-3 Example of a LD2-02S

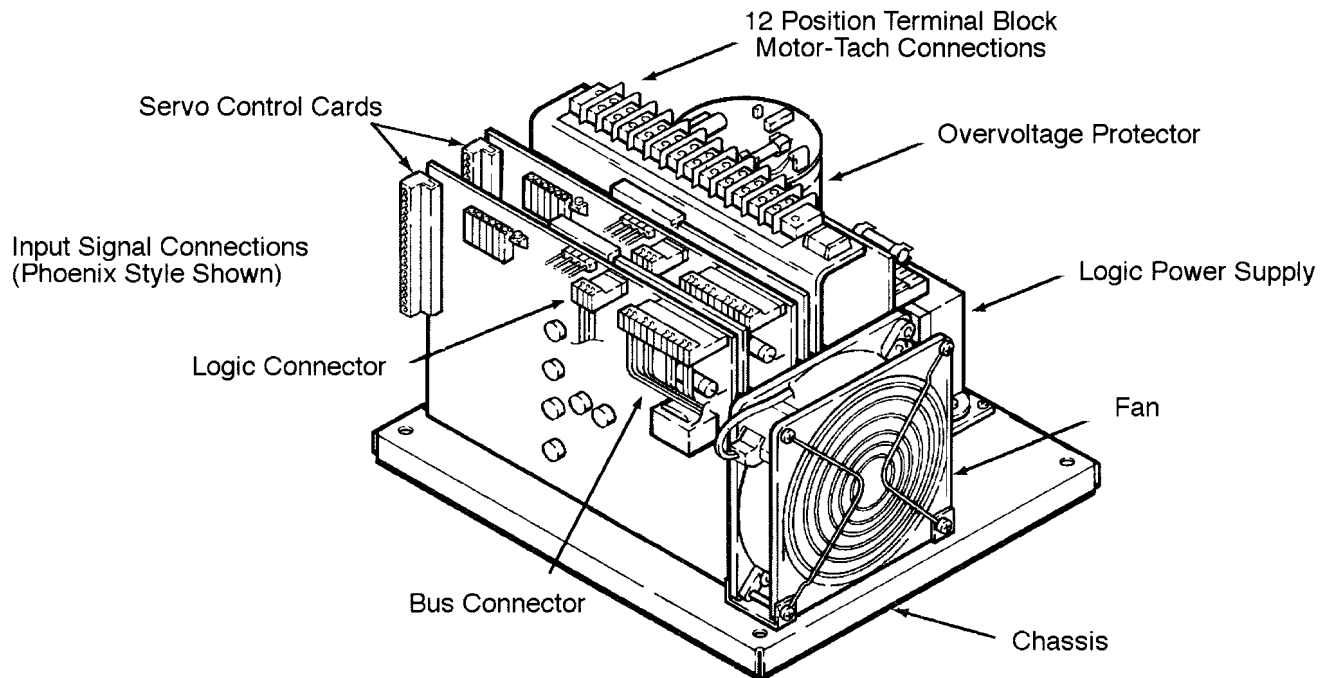

Adjustments	Each servo control card contains six (6) potentiometers located on the top left side of the unit. The location of each potentiometer is provided in Figure 1-4.
Auxiliary (A)	(A) pot is used to adjust the gain of an optional single ended input voltage between ± 10 VDC. The effect of changing the gain enables the installer to vary the motor speed for a given signal input voltage.
Signal (S)	(S) pot is used to adjust the gain of a single ended or optionally configured differential input voltage between ± 10 VDC. The effect of changing the gain enables the installer to vary the motor speed for a given signal input voltage.
Tachometer (T)	(T) pot is used to adjust the tachometer circuit gain. The effect of changing the gain enables the installer to vary the overshoot or stiffness of a motor as it is commanded to change speeds.
Response (R)	(R) pot is used to adjust the overall velocity loop gain. The effect of changing the gain enables the installer to vary the stiffness of the velocity loop to minimize the overshoot of the axis when responding to a step input voltage.
Current Limit (C)	(C) pot is used to attenuate the peak current output to the servomotor. This can effectively reduce the overall RMS current in applications, which are subjected to constant acceleration and deceleration changes.
Balance (B)	(B) pot is used to compensate for the digital to analog offset errors. This will allow for fine tuning the zero speed when the input device is installed and there is no signal-input voltage to the servo control.

Figure 1-4 Adjustment and Indicators

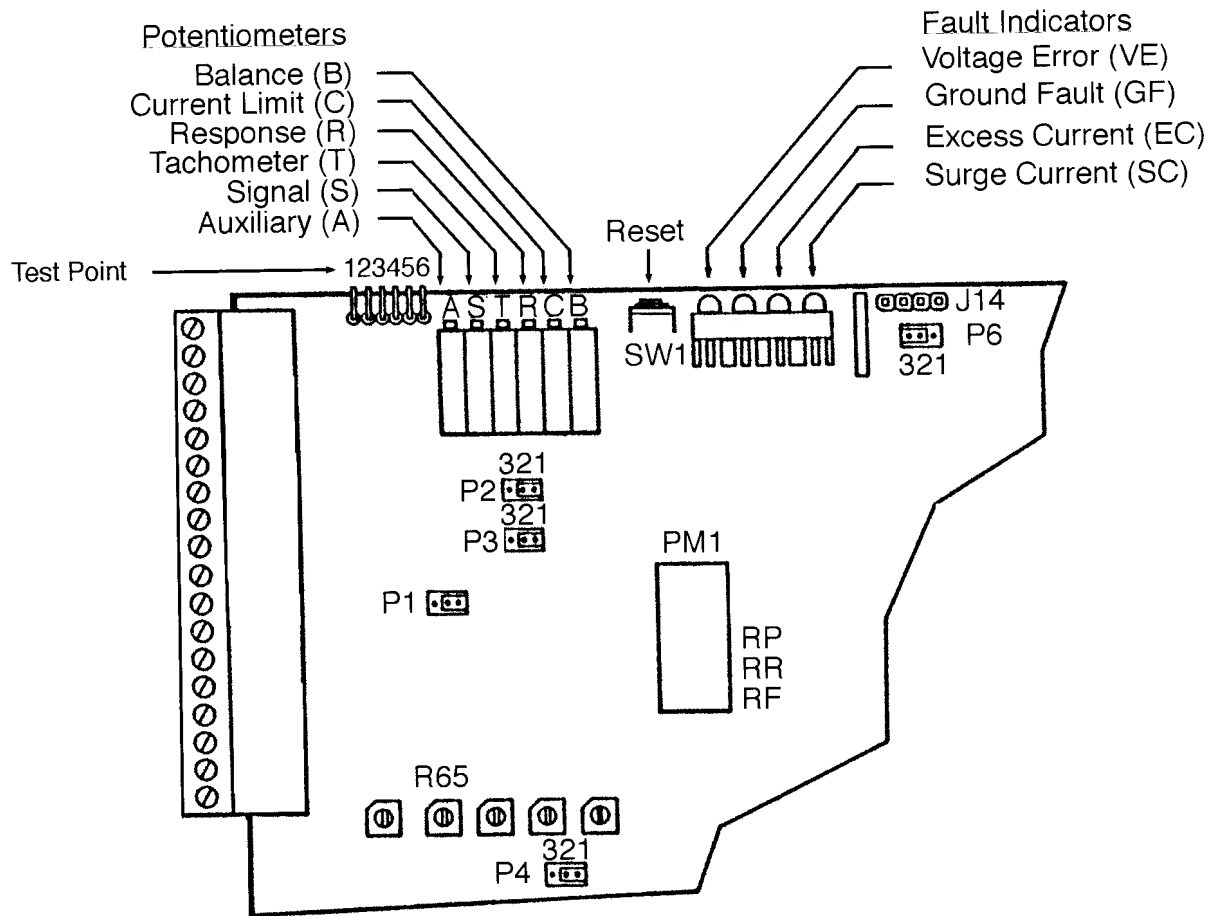

Optional Adjustments

Each servo control contains six jumper settings and a personality module that can be used to custom tailor the module to the application (for location see Figure 1-4). Underlined positions indicate the factory default settings.

- P1 Right position (pins 1 and 2) when normally opened switches are used.
Left position (pins 2 and 3) when normally closed switches are used.
- P2 Right position when using a differential input.
Left position for single ended input.
- P3 Right position for reading actual current (+ or –) on the DCS current monitor.
Left position for the absolute value. (always positive)
- P4 Right position for EC (Excess Current) latch function
Left position for current foldback mode, where current is limited to a lower fixed level.
(See Appendix B)
- P5 A factory installed resistor (P5) which is on-board the personality module. This is to ensure that the servo control will not function without the personality module in the socket.
- P6 Left position for velocity mode operation.
Right position for current mode and for use in positioning applications with

Personality Module

The personality module has 3 after factory adjustable settings (for location, see Figure 1-4). With the appropriate 1 % resistor soldered into the socket, peak current, RMS current, and the foldback level can be adjusted. Motor compensation values are also on this module, allowing custom compensation on specialty motors. These components are already appropriate for Baldor DC servomotors. For a description of the current settings, see Appendix B.)

Set Up Testpoints

Six testpoints have been added to help with set up and the replacement of a card. Once a card is set up, the potentiometer's resistance can be measured and recorded for future reference. Other cards can be preset to these values minimizing the need to set up each card on the particular piece of equipment.

Test Point	Description
TP1	Common
TP2	"A" Pot Wiper Resistance
TP3	"S" Pot Wiper Resistance
TP4	"T" Pot Wiper Resistance
TP5	"R" Pot Wiper Resistance
TP6	Tach monitor (measures actual tach voltage)

Reset Button

A momentary push button (SW1) is mounted on the top of the servo control card next to the adjustment potentiometers (for location, see Figure 1-4). This allows you to restart (reset) a control that has shut down.

Fault Indicators

Each servo control card contains four (4) red fault indicators located on the top left side of the unit (for location see Figure 1-4). Each fault is a latch type function (unless in Foldback Mode) where the servo control card will not function when tripped. A reset must be done in order to restart the servo control. Refer to Section 4 – Troubleshooting for detailed information on solving fault problems.

Voltage Error (VE)

The purpose of the (VE) indicator is to identify either excess bus voltage detected by the overvoltage protector or insufficient logic voltage at the servo control.

Excess Current/Overtemperature (EC)

The purpose of the (EC) indicator is to identify either excess RMS current or over temperature condition.

Ground Fault (GF)

The purpose of the (GF) indicator is to identify if current is flowing at or leaking to ground potential in either the motor or servo control.

Surge Current (SC)

The purpose of the (SC) indicator is to identify a peak current draw, which exceeds the rating of the servo control.

Status Indicators

The logic power supply on the chassis has four (4) green status indicators (see Figure 1-5) which when lit verify the presence of the +15 VDC, -15 VDC, AC for fans and logic, and Bus voltage (DC).

Figure 1-5 Status Indicators

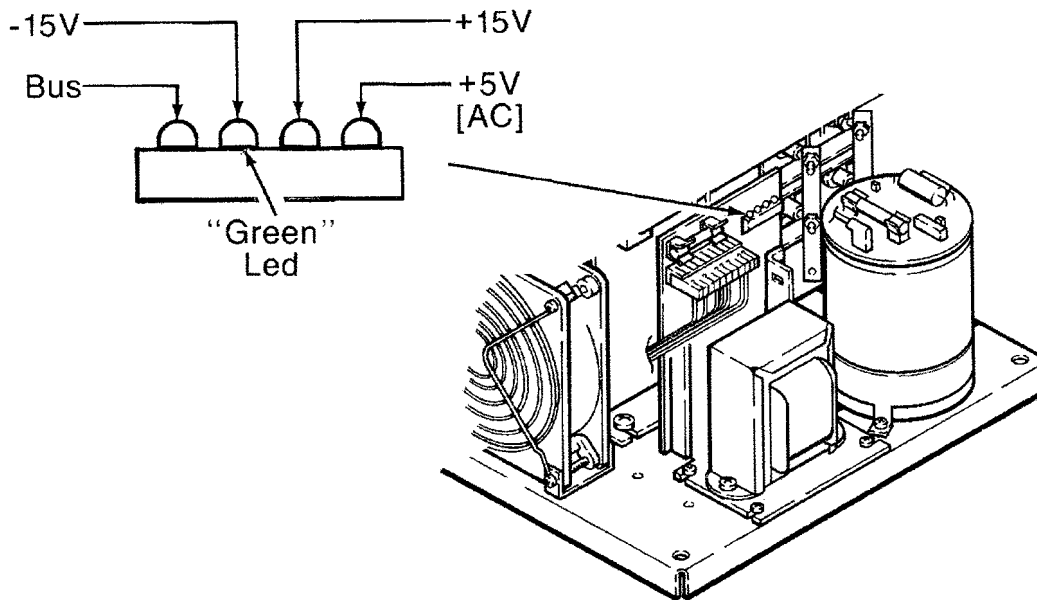
**NOTE:**

“LD” Series power supply is marked with “+5V”. However, this voltage is not supplied. It is supplied only on the “SLD” version.

Tools

There are a few basic tools recommended to install the "LD" Servo Control.

Recommended Tools	Description and Use
Slotted screw driver, medium size	Terminal strips, chassis and possibly transformer
Slotted, very small screw driver (or pot adjustment tool)	Potentiometer adjustment and screw terminal connections
Phillips, screw driver medium large with 8" long shank (required if replacing or adding servo control cards)	Add or remove modules
Phillips, screw driver medium	Input connections to AC bus power
Crescent Wrench (6" or 8")	Disassemble packaging from chassis
VOM meter	Testing continuity, verifying Voltage, current, polarity, etc.
A number of other common tools are recommended in order to do a proper job i.e. solder iron, solder, crimp tools, wire stripper, etc.	

Section 2 Installation

Receiving & Inspection

Baldor Controls are thoroughly tested at the factory and carefully packaged for shipment. When you receive your control, there are several things you should do immediately.

1. Observe the condition of the shipping container and report any damage immediately to the commercial carrier that delivered your control.
2. Remove the control from the shipping container and remove all packing materials. The container and packing materials may be retained for future shipment.
3. Verify that the part number of the control you received is the same as the part number listed on your purchase order.
4. Inspect the control for external physical damage that may have been sustained during shipment and report any damage immediately to the commercial carrier that delivered your control.
5. If the control is to be stored for several weeks before use, be sure that it is stored in a location that conforms to published storage humidity and temperature specifications.

Location Considerations

The location of the control is important. It should be installed in an area that is protected from direct sunlight, corrosives, harmful gases or liquids, dust, metallic particles, and vibration. Exposure to these can reduce the operating life and degrade performance of the control.

⚠ CAUTION: Avoid locating control immediately above or beside heat generating equipment, or directly below water or steam pipes.

⚠ CAUTION: Avoid locating control in the vicinity of corrosive substances or vapors, metal particles and dust.

Several other factors should be carefully evaluated when selecting a location for installation:

1. For effective cooling and maintenance, the control should be mounted on a smooth, non-flammable vertical surface.
2. At least two inches top and bottom clearance must be provided for air flow.

Installing the Servo Control Card

This procedure is to be followed only if the Servo Control Cards have not been mounted to your chassis. If the cards are already installed, skip this procedure and continue with Mount the Chassis.

1. Prepare to mount the card by loosening the two phillips head machine screws located on base of chassis (see Figure 2-1).
2. Open the shipping carton, remove the card enclosed in plastic, anti-static protective bag.
3. Remove the card from the bag and slip the module's slotted tabs under the screw heads.
4. Tighten the screws moderately with a long phillips head screwdriver.
5. Repeat the mounting procedure for each card.
6. On the prewired chassis cable harness, grasp the large connector (female "Bus Connector") and plug it into the row of pins (J6) at the upper right corner of the card near the fan (see Figure 2-1). Take care to ensure proper alignment as there is only one correct position .
7. Grasp the small connector (4 socket female "Logic Connector") from the same harness and plug it into J5 (see Figure 2-1). Again make sure it is properly aligned on the 4 pins.

Figure 2-1 Installing the Module

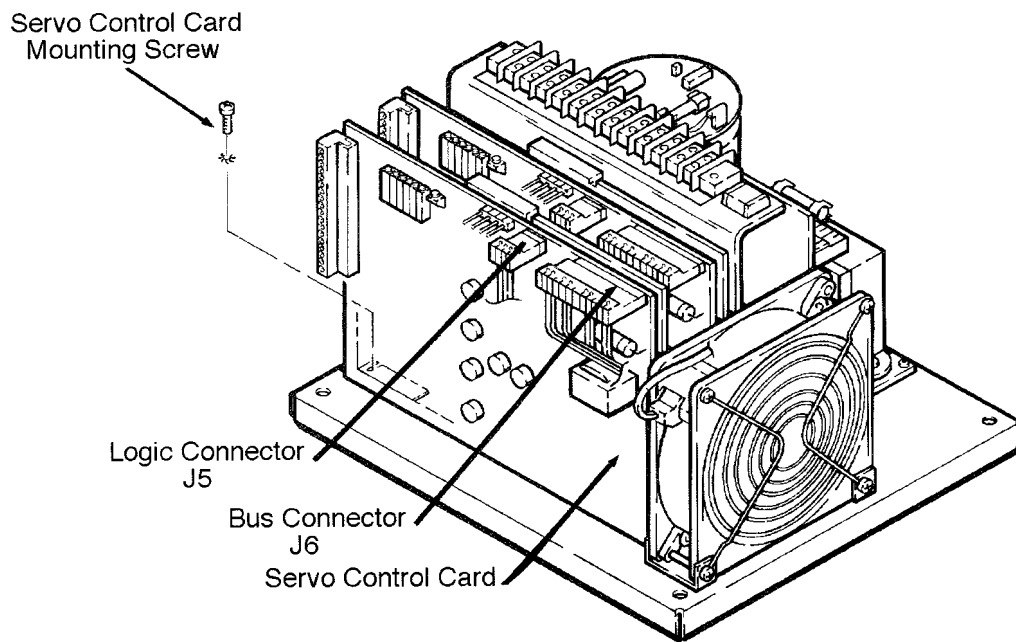

Mount the Chassis

1. Remove the shipping base by taking off the four nuts and bolts at the corners of the chassis.
2. Select an appropriate mounting location that meets the vapor, vibration and particle avoidance requirements stated in General Precautions in section 1.
3. Lay out the hole pattern according to the dimensions of your chassis. Refer to Appendix A for dimensions.
4. Cut any wiring openings needed in the cabinet, debur the edges, and bolt the chassis securely within the equipment enclosure. Use one of the mounting bolts to attach a ground strap to earth ground.

General Wiring Considerations Care should be taken to see that all interconnecting wiring is sized and installed in conformance with the National Electrical Code (NEC) or Canadian Electrical Code (CEC) and other applicable local codes.

To minimize electrical interference problems, interconnecting wires should be arranged in groups. As a minimum, two groups should be used; (1) high current, high voltage power wiring such as main power input, 115 VAC for fans, relays, contactors, etc. DC wiring for motor power and (2) low level signal wiring such as input speed commands, tachometer feedback, inhibit/enable signals, etc. It is recommended that wire groups be separated by at least one foot, or run in separate grounded conduits. All wiring should be kept as short as possible.

As a general rule, use only wires of adequate size for their length and current being carried. Specific recommendations for each major group follows. For critical applications, finer subdivision into wire groups of like functions is advised.

Power Wiring

All power wiring for the cooling fans, motor power and input power connections should be no less than 16 AWG gauge or equivalently rated wire. It is suggested that power wires be run as twisted pairs, i.e., twist the wire carrying current with the same wire returning the current. Twisting the wires will reduce radiated electrical noise. In systems particularly sensitive to electrical noise, use of shielding for the motor power wiring might be considered.

Grounding

Proper grounding helps guard against electrical shock to personnel and can reduce the effects of electrical noise interference. Each chassis/power supply assembly should be grounded. One mounting bolt can be used to attach a ground wire. The chassis ground wire should have a green or green with yellow stripe insulation. In addition to the chassis grounds, the cabinet which houses the equipment should have a separate connection direct to earth ground on the power distribution panel.

The system ground should be designed in a tree fashion with individual ground wires converging to a single earth ground point. Ground wires should be short and large enough to carry the maximum short circuit current rating of the circuit, as determined by the fuse rating on the incoming power. Consult local governing codes for compliance with safety regulations before finalizing the grounding system.

Signal Wiring

All signal wiring and limit circuit wiring need not be larger than 22 AWG gauge. Signal circuits, including the tachometer, should employ twisted, shielded pairs. Proper termination of shielded cables is important to avoid creating ground loops or otherwise degrading the noise immunity of the servo package. Cable shields should be terminated at one end only. The other end should be left floating but insulated by electrical tape or some other means to prevent contact with any metallic part. In most applications, satisfactory noise immunity will be realized with the signal line shields terminated at the respective signal input points. Note: Always reference the shield to the low side of the signal wires which the shield is to protect. Earthing or grounding the shield does little good unless the signal is also referenced to the same point. It is important to maintain the continuity of cable shields through any intervening connector and/or terminal blocks. Try to minimize the length of unshielded cable at these points.

Electrical Noise Suppression

Electrical noise suppression requires a thorough system design using a combination of good grounding practices, shielded cable, cable separation and suppressors. The customer must provide suppression of transient voltages in his equipment, which may occur when interrupting current to an inductive load.

Wiring Instructions

Power Wiring

Wire the unit according to the National Electrical Code (NEC) as well as your local requirements. Motor power and AC input wiring should be appropriate for the continuous rated current for the motor being used.

The connections and the wiring can vary between chassis depending on the user's requirements and the terminal strip options chosen.

Note: Refer to the drawing in Appendix A before connecting the unit and integrating it into the system.

Note: LD-2 units have screw type terminals for L1 and L2.
LD-4 units have screw type terminals for L1, L2 and L3.

Figure 2-2 Power Wiring

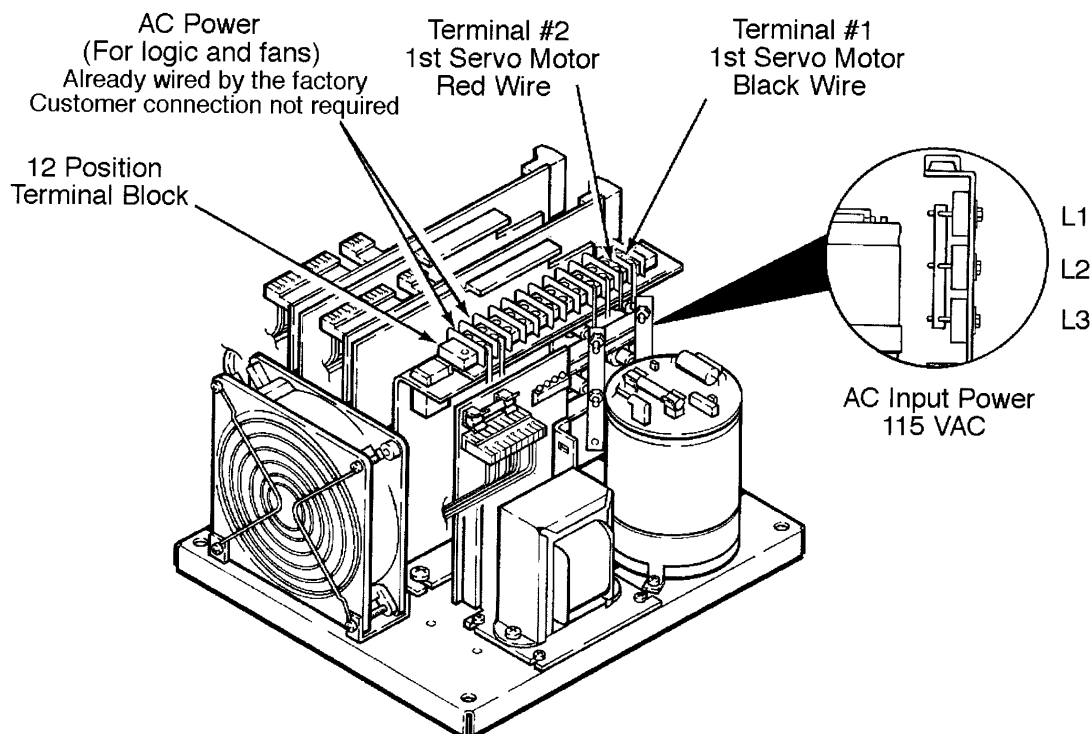

Power Wiring Continued

1. Connect the negative lead (black wire) from the first servomotor to terminal 1 on the 12 position terminal block (see Figure 2-2).
2. Connect the positive lead (red wire) from the first servomotor to terminal 2 on the 12 position terminal block (see Figure 2-2).
3. For the second axis servomotor, connect the negative lead (black wire) to terminal 3; and the positive lead (red wire) to terminal 4. Repeat this procedure for any other axes (Refer to drawing in Appendix A).
4. Do not at this time connect any AC power to the chassis.
5. Wire the AC power input to the screw-type terminals on the rear of the chassis as shown in Figure 2-2. Do not connect any AC power at this time. Phasing is not critical on the bus power input. For LD-2 units, use the two terminals marked L1 and L2 and connect 115VAC 1 phase power. For LD-4 units, use the three terminals L1, L2, and L3 and connect 3 phase power.

Signal Wiring

1. Connect the positive (+) side tachometer lead wire (of the first servomotor) to the Tach input (pin 5) on the 18 position Phoenix style input signal connector (see Figure 2-3).
2. Connect the negative (-) side tachometer lead wire (of the first servomotor) to the Tach input (pin 6) on the 18 position Phoenix style input signal connector (see Figure 2-3). Tie the tachometer cable shield to pin (11) common.
3. Continue connecting remaining tachometer lead wires for other axes (Refer to drawing in Appendix A).

Figure 2-3 Input Signal Wiring

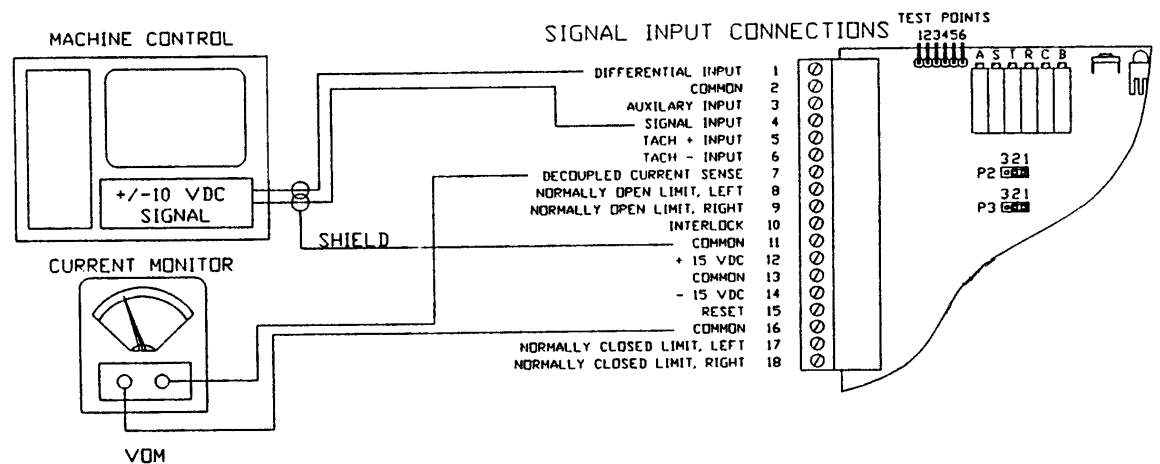

4. Differential Command input
The "LD" Series Servo Control is configured to operate using a differential command input signal. To utilize differential input, jumper P2 (see Figure 2-3) must be in its right position (pins 1 to 2). This is the normal position as shipped. The Servo Control Signal pot (S) will be used to scale the differential voltage input.
5. Connect the input velocity command signal to pin 1 and its return to pin 4.
Note: Do not apply voltage at this time.
6. Verify the first axis tachometer signal by rotating the first axis motor shaft by hand while monitoring the tach test points with a VOM. Connect the black lead of the VOM to test point TP1 and the red to TP6. When rotating the motor shaft in a clockwise direction (facing the shaft), the VOM should read positive.

Input Wiring Connections

Left Limit, Right Limit

(Pins 8 & 9 for Normally Open, 17 & 18 for Normally Closed)

When the Left or Right limit is pulled to common (for normally open switches), output is inhibited in that direction. This function disables the control and the motor will coast to a stop. This function can be used for an axis overtravel limit to prevent further operation in the inhibited direction, but it does allow the drive to back out of the limit. Jumper P1 on the servo control allows you to select either normally open or normally closed limit inputs.

The normal position as shipped is P1 jumper right (pins 1 to 2). If normally closed switches are to be used, then this circuit must be first activated by placing jumper P1 in the left position (pins 2 to 3).

Note: If P1 is in the left position and limit switches are not used in the application, the control will assume the switch has opened and disable its output in that direction, unless the right and left limits (pins 17 & 18) are tied to common.

Optional Wiring

Single Voltage Input (pin 4 to 2)

The servo control can be configured to operate using a single ended positive or negative voltage command input signal. Move jumper P2 from its right position to its left position (pin 2 to 3).

Use the servo control Signal (S) pot to scale the single voltage input. Rotate (A) pot full counterclockwise.

Current Monitor Interface (Pins 7 & 11).

Decoupled Current Sense (DCS) is an analog representation of servo control current. Using an oscilloscope, the output current can be viewed. An analog output voltage of 1 volt peak to peak represents approximately 1/10 of peak current. If you have a LD3015HS servo control card and your DCS voltage is 1.5V peak, amplifier output current is:

$$30 \text{ amps peak } 1/10 \times 1.5 = 4.5 \text{ amps output}$$

OR

$$3 \times \text{DCS voltage} = \text{output current (for LD3015)}$$

Figure 2-4 Optional Input Signal Wiring

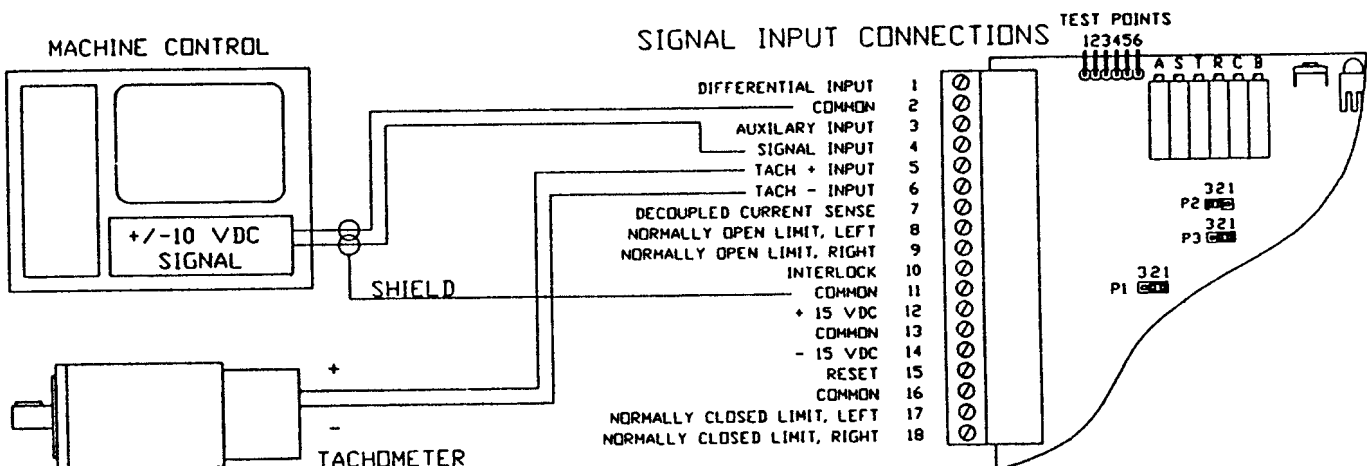
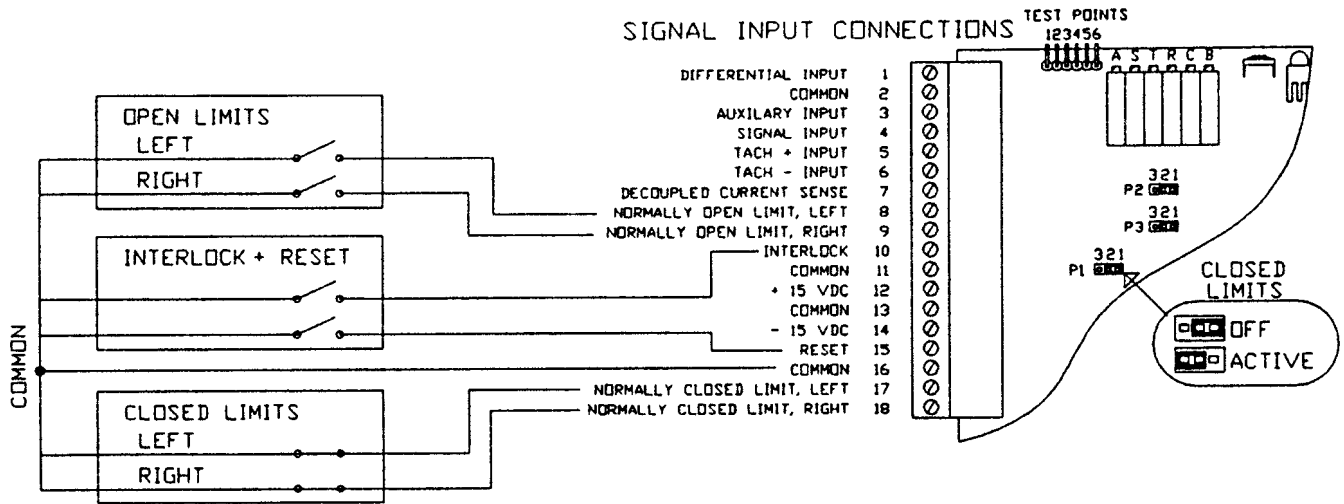

Figure 2-5 Optional Input Signal Wiring



Interlock (Pin 10)

The interlock is bidirectional. That is, it can be pulled to common internally to disable the output stage of the control or externally to accomplish the same disabling function (see Figure 2-5). The internal pull down function occurs as a result of:

- High bus or low bias voltage. (VE Indicator ON)
- Ground Fault current. (GF Indicator ON)
- Excessive I²T current or overtemperature (in latch mode). (EC indicator ON)
- Excessive bus surge current. (SC Indicator ON)

The interlock function can be used to tie multiple servo control cards together thus locking all cards together. If wired in this configuration and a fault condition occurs on one axis card, all other cards will also be interrupted. An Emergency E-stop could also be wired to the interlock line, upon switch closure the output stages of all servo control cards will be disabled (i.e., motors will coast to a stop with no holding torque). See Section 5 for additional information on Emergency Stop.

Reset (Pin 15)

The reset line is used to externally reset the servo control. When the reset signal is tied to common temporarily and then released, the control will be enabled (restarted) if a fault condition is not present. If activated, the reset line will totally disable the servo control card. The reset button (SW1) (a momentary switch) was added for your convenience and will provide the same results.

+15 VDC/-15 VDC (Pins 12 & 13)

This is an available logic power source with a 50 mA maximum load which can be used to support external devices or can be used with a voltage divider network to provide the signal input to the servo control card.

Section 3

Start-up

Overview

The start-up information provided in this section contains the procedures necessary to get each axis running and properly tuned using the 6 adjustment potentiometers on the servo control. Each axis should be started up independently to insure that catastrophic problems do not cause damage to the equipment. It is further recommended that the load is not connected to the servo control until you are familiar with the control.

Initial Potentiometer Settings

Potentiometer	Position	Condition
A (Auxiliary)	Fully counterclockwise	Off
S (Signal)	Fully counterclockwise	Off
T (Tachometer)	Fully clockwise	Low
R (Response)	Fully counterclockwise	Low
C (Current Limit)	One turn clockwise	Low
B (Balance)	Leave as shipped	Center

Note: All pots have a 15 turn range and are without a hard stop. You may hear a 'click' when the end is reached.

Start-up (Power On)

To minimize the potential damage to the machine during power up, disconnect all axis except the first (X-axis).

1. Apply the 115 VAC to the AC power input.
2. Observe that the fan starts and 4 of the green LED's on the logic power supply (+15V, -15V, AC, and "BUS") illuminate.
3. Observe that the servomotor on number 1 axis (X) did not rotate. If the servomotor runs up to a high speed at an uncontrolled rate, reverse the tachometer or motor power leads.

Adjustment Procedure

⚠ Caution: The X–Axis motor may tend to run away, out of control, if the tach wires are reversed. If the axis moves in the wrong direction, the motor wires are reversed. If, however, reversing the leads doesn't stop a runaway motor, make sure the T (Tachometer) potentiometer is not full counterclockwise.

1. Apply a signal step input command between 0 and 10 VDC at positions 1 and 4 on the signal input connector. (Suggest 5 VDC input voltage)
2. Slowly turn the (S) Signal pot 4 turns in the clockwise direction observing that the motor shaft rotates at a reasonably controlled rate.
3. Slowly turn the (C) Current pot 4 turns in the clockwise direction (motor shaft speed may increase and stabilize). If the X axis motor shaft runs to a high or uncontrolled rate, reverse the tach wires coming to the signal input connector.
4. If the X axis motor shaft rotates in the wrong direction for a given polarity of the signal input voltage, reverse both the tachometer wires along with the red and black motor power wires on the terminal block.
5. If connected, verify that the Left and Right limit switches properly inhibit the axis travel in the direction defined. The normally open limits are activated when tied to common.
6. Slowly turn the (S) pot clockwise to increase the motor shaft speed to full speed.
7. If a high output voltage tachometer is used, it may be necessary to turn the (T) pot a few turns counterclockwise to achieve the desired speed.
8. Slowly turn the (C) pot to the full clockwise position if the servo control's peak current is less than the rated peak current of the motor. If the peak motor current is less than that of the servo control, a reduced current **MUST** be maintained.

Note: The following 5 steps (9 through 13) are to be followed in setting up each axis before connecting the servo motors to the equipment. The following procedure should also be used after the equipment has been installed with a load and control applied for the final fine tuning.

9. Slowly turn the (R) pot in the clockwise direction until the axis becomes unstable and then turn the pot back one turn in the counterclockwise direction. This adjustment is best done with a step input command.
10. If the motor shaft rotates with the signal input voltage at zero; slowly turn the (B) pot to eliminate any motor shaft rotation.
11. If the motor shaft overshoots when stopping, turn the (T) pot in the counterclockwise direction being careful not to turn to full counterclockwise. Full counterclockwise on the (T) pot may cause the motor shaft speed to become uncontrollable.
12. The (S) pot can now be adjusted to optimize the maximum response for the given signal input voltage range.
13. Repeat the wiring instructions in Section 2 of this manual and the Start-up procedure in this section for each servo motor and servo control card.

Section 4

Troubleshooting and Maintenance

Overview

This troubleshooting section describes the symptoms of possible malfunctions along with information needed to check and correct the causes of a fault. Using the four LED fault indicators on the Servo Control Card and a VOM can identify most of the faults.

Unless the cause of a malfunction is obvious and readily correctable, replace the servo control card with a new one. This will get the system running most quickly and reduce equipment down time.

Under no circumstances should you modify or replace any components. This could compound the problem as well as voiding the warranty.

If a problem develops in a system that was previously operating well, do not make any adjustments without first diagnosing the cause or causes. To arbitrarily readjust the unit will only compound the problem.

Work from the four LED indicators and from the troubleshooting table in this section.

Initial Checks

Begin your troubleshooting with a systematic and complete check of power lines and input signals to the servo control.

⚠ WARNING: Do not touch any circuit board, power device or electrical connection before you first ensure that power has been disconnected and there is no high voltage present from this equipment or other equipment to which it is connected. Electrical shock can cause serious or fatal injury. Only qualified personnel should attempt the start-up procedure or troubleshoot this equipment.

⚠ WARNING: Do not remove cover for at least five (5) minutes after AC power is disconnected to allow capacitors to discharge. Electrical shock can cause serious or fatal injury.

1. Check input speed command signals. Determine that they reach the servo control input connector.
2. Check the external limit switches if used to determine that they are functioning properly.
3. Check the 115 VAC power to determine that it is correct.
4. Check for open fuses and circuit breakers.
5. Check for correct jumper positions.
6. Check for damaged control or equipment wiring.
7. Check for loose or broken terminals.
8. Check for abnormally hot components.
9. Check for burned insulation or components.

Resetting the Servo Control To reset a servo control with a fault, the following procedure must be performed.

1. Check over the servo control and wiring for obvious problems.
2. Review the following troubleshooting table for a possible explanation of the cause and corrective action to be taken.
3. Reset the axis by either taking the reset line on the signal input connector and touching it to common and releasing, or depressing the reset button.

Note: Remove incoming AC power before changing AC fuse. To gain access to change fuse, press fuse holder cover to the side and lift up. Install new fuse and press cover down securely to re-seat fuse cover, noting that it snaps back in place. Re-apply incoming AC power.

Fault	Symptom	Corrective Action
N/A	No torque in one direction.	Check left or right limit switch wires to ensure that they are not tied to common. Verify that the proper limit switches are used. Verify P1 position
	No output in either direction.	Check interlock and reset wires to ensure that they are not tied to common. Perform set-up procedure and verify all connections. Observe if all 4 green LED's are lit on logic supply. If all 4 LED's are not lit, perform start-up procedure in Section 3 and recheck all steps. If only (bus) LED is lit, check AC logic fuse on top of unit to verify it is good and set in the holder. Verify P1 jumper is not missing.
	Motor runs at uncontrolled speeds	Verify that the servo control is not set for current mode. Verify P6 position. Verify that (T) pot is not set full CCW. Reverse tach leads and verify that tach voltage is present at signal input connector when motor is running.
	Oscillation in motor seen as instability or rocking of motor shaft. Motor may have growling sound.	Refer to Start-up and Adjustment Procedures for proper setting of (R) and (T) pots.
	Motor exhibits a "dead zone" when responding to a signal input.	Verify that the bus voltage is sufficient for the motor. Verify that inductance is not overly high (see specifications in Section 1). Refer to Start-up procedures for proper setting of (R) pot.
VE	Low output voltage from logic power supply.	Check incoming power to logic power supply and verify that it is in specified range. If in range, disconnect any external load on logic power and reset servo control.
	Bus Voltage too high.	Check fuse on shunt regulator. Recheck voltage and if problem still exists, disconnect power to each servo control individually and isolate which servo control is drawing excess current. Check to ensure (T) pot is turned too far CCW.
EC	RMS current output is exceeded.	Check axis for instability (oscillation). Correct by turning (R) pot CCW.
	Overtemperature on servo control.	If not instability, look for high tach noise (over 5% p-p) by using an oscilloscope. If noise is present, check tach shielding. If overloading is suspected, a larger servo control may be required. Contact your supplier for alternatives. Verify that air circulation is present. Check for overload using oscilloscope on the DCS line to determine current to motor. 1V is approximately 1/10 of the peak rated output current. If not overloaded, unit should be returned for repair.
GF	Current flow is detected at ground potential	Can be caused by a short to ground. Remove armature connections and check for short to ground. If none exists, remove servo control and reset unit. If problem is resolved, servo control should be returned for repair.
SC	Rated peak current has been exceeded.	Verify that motor has sufficient inductance (see Section 1.5.2). Reset servo control and see if problem immediately reappears. If so, check for short in motor. If motor is not shorted, unit has an internal short and should be returned for repair. If upon resetting servo control, the unit does not fault, cycle equipment while watching for a fault during acceleration. If fault occurs, increase the acceleration time, reset and cycle until problem is eliminated.

⚠ WARNING: Do not touch any circuit board, power device or electrical connection before you first ensure that power has been disconnected and there is no high voltage present from this equipment or other equipment to which it is connected. Electrical shock can cause serious or fatal injury. Only qualified personnel should attempt the start-up procedure or troubleshoot this equipment.

⚠ WARNING: Do not remove cover for at least five (5) minutes after AC power is disconnected to allow capacitors to discharge. Electrical shock can cause serious or fatal injury.

Maintenance

The only periodic maintenance required on the servo control is an occasional inspection for accumulated dust or dirt on the heat sinks and circuit boards. Heat sinks must be kept clean for maximum cooling efficiency. Also, shop dust in some environments tends to be electrically conductive and can cause servo control malfunction.

1. If cleaning is needed, carefully vacuum loose dirt or use dry compressed air.
2. Remove power and ensure that bus capacitor voltage has bled down before checking connections.
3. Periodically check all connections and fasteners for tightness.

Servo Control Card Replacement

1. Remove power and ensure that the bus capacitor voltage has bled down. DO NOT short capacitor with a screwdriver or clip lead.
2. Measure capacitor voltage with a voltmeter or wait for 3 minutes for capacitor to bleed off.
3. Disconnect both of the module top edge connector by holding printed circuit board while pulling connector away from board.
4. Disconnect the signal-input connector in the same fashion.
5. Loosen the chassis mounting screws (module heatsink brackets are slotted) and slide module out from chassis.

Section 5 Special Functions

Current (Torque) Mode

The “LD” can be configured for current mode operation by moving jumper P6 to its right position (pins 1 to 2). This current mode operation is useful in applications where commanded motor torque must be proportional to a voltage at the signal input. Since torque is proportional to motor current, constant current must be provided to the motor to develop constant torque. The current mode operation differs from standard operation in that the velocity loop is basically disabled (gain is reduced from 6000 A/V to approximately 6 A/V). The remaining current loop controls the output current proportional to the input voltage (VCS).

Typical applications requiring current mode operation are:

- Web controls
- Brake applications
- Bolt tightening

Current mode operation is useful if a programmable motion controller is precisely controlling the velocity loop. In this configuration tachometer feedback is not required.

To convert a velocity control amplifier to a current amplifier (Refer to Figure 5-1).

1. Move the P6 jumper to its right position (pins 1 to 2).
2. The T pot must be rotated fully counter-clockwise.
3. The S pot should be set fully clockwise.

Note: if the A pot is used, set full clockwise and the S pot counter-clockwise.

Figure 5-1 Servo Control Card

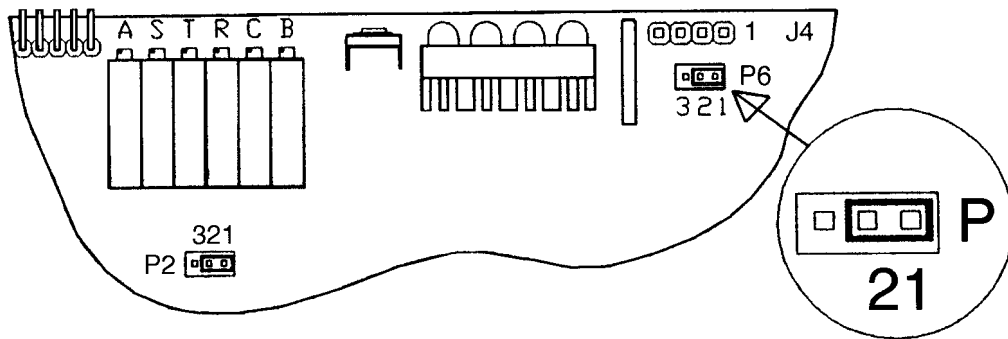

Emergency Stop

In some applications, a requirement may exist to positively disconnect a motor in the event of an emergency (E) stop.

A suggested approach using a relay with 4 sets of contacts could be applied as shown in Figure 5-2, providing a power disconnect of motor and servo control in the event of an E stop.

Figure 5-2 Power Contactor for Positive Disconnect

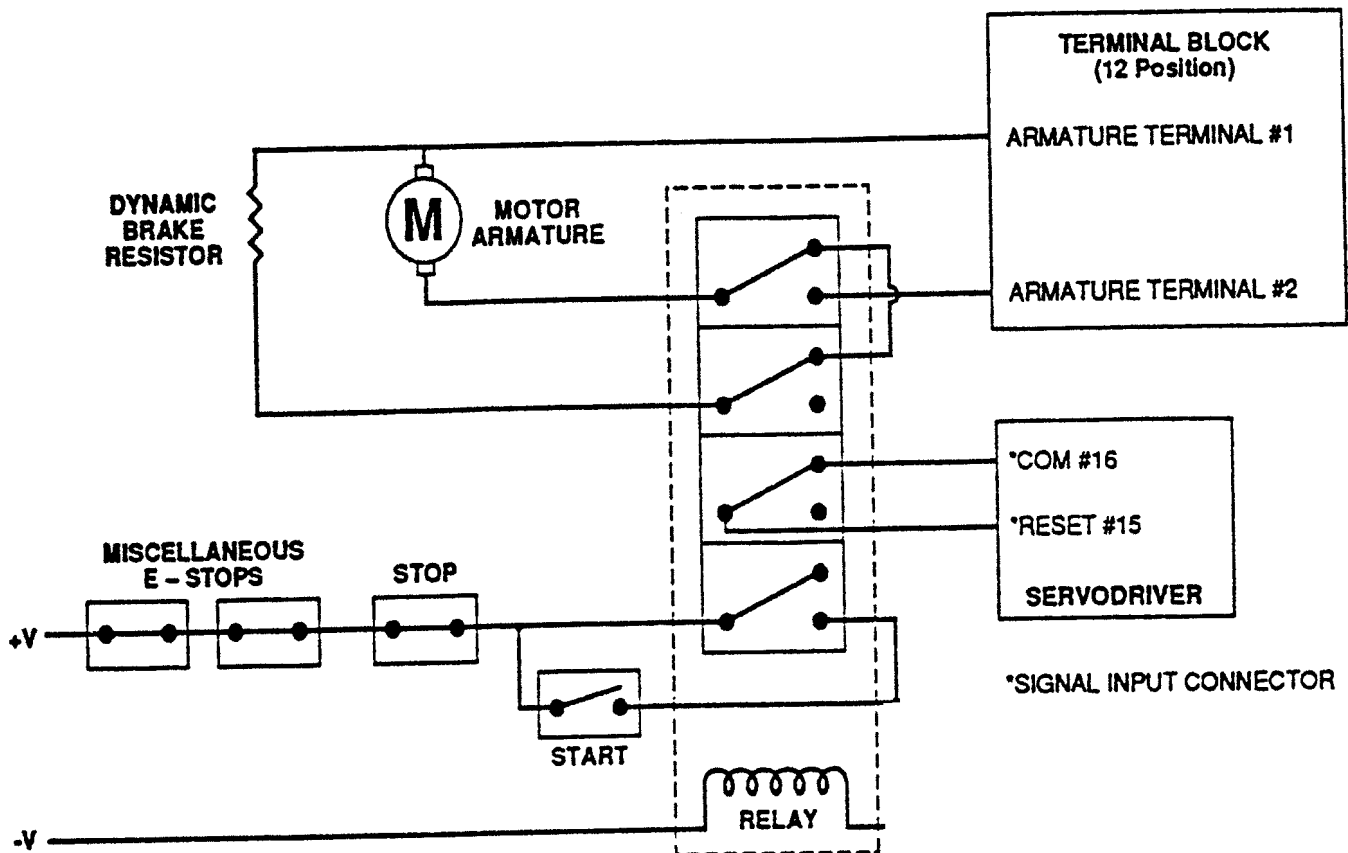

Appendix A

Condensed Installation Instructions

Step 1

Become familiar with the equipment. You should have:

1. Servo Control Cards of the type and quantity you have ordered, mounted to the chassis.
2. Chassis Assembly which also includes:
 - Logic power supply (bias supply)
 - Overvoltage protector (shunt regulator)
 - Bus power supply

In addition to the above you will find an Installation and Operating Manual and input connector which are attached to the servo control cards.

Step 2

Read the Installation and Operating Manual.

It contains detailed installation and start up procedures and drawings pertaining to your equipment. Specific CAUTIONS must be adhered to so that equipment or personnel are not damaged or injured.

Step 3

Mount the Chassis Assembly.

⚠ WARNING: Do not apply power until all connections are made, connections are checked and the safety precautions in Sections 1 are read and understood.

Step 4

Connect the Motors.

1. Connect motor armature leads to the motor output terminals on the chassis assembly. Refer to Figure A-1.
2. Connect the tachometer leads to the input connector A1, pins 5 and 6. See input connector Installation Drawing. Be sure that the armature and tach are connected to the same axis.

Step 5

Connect Power to the Chassis Assembly.

Connect the power source to the input terminals. Use caution when connecting 115VAC to LD-2 (one input power units) and LD-4 (two input power units). Refer to Figure A-1.

Step 6

Refer to Section 3 for Start Up and Adjustment instructions.

Figure A-1 Series "LD" Installation Drawing

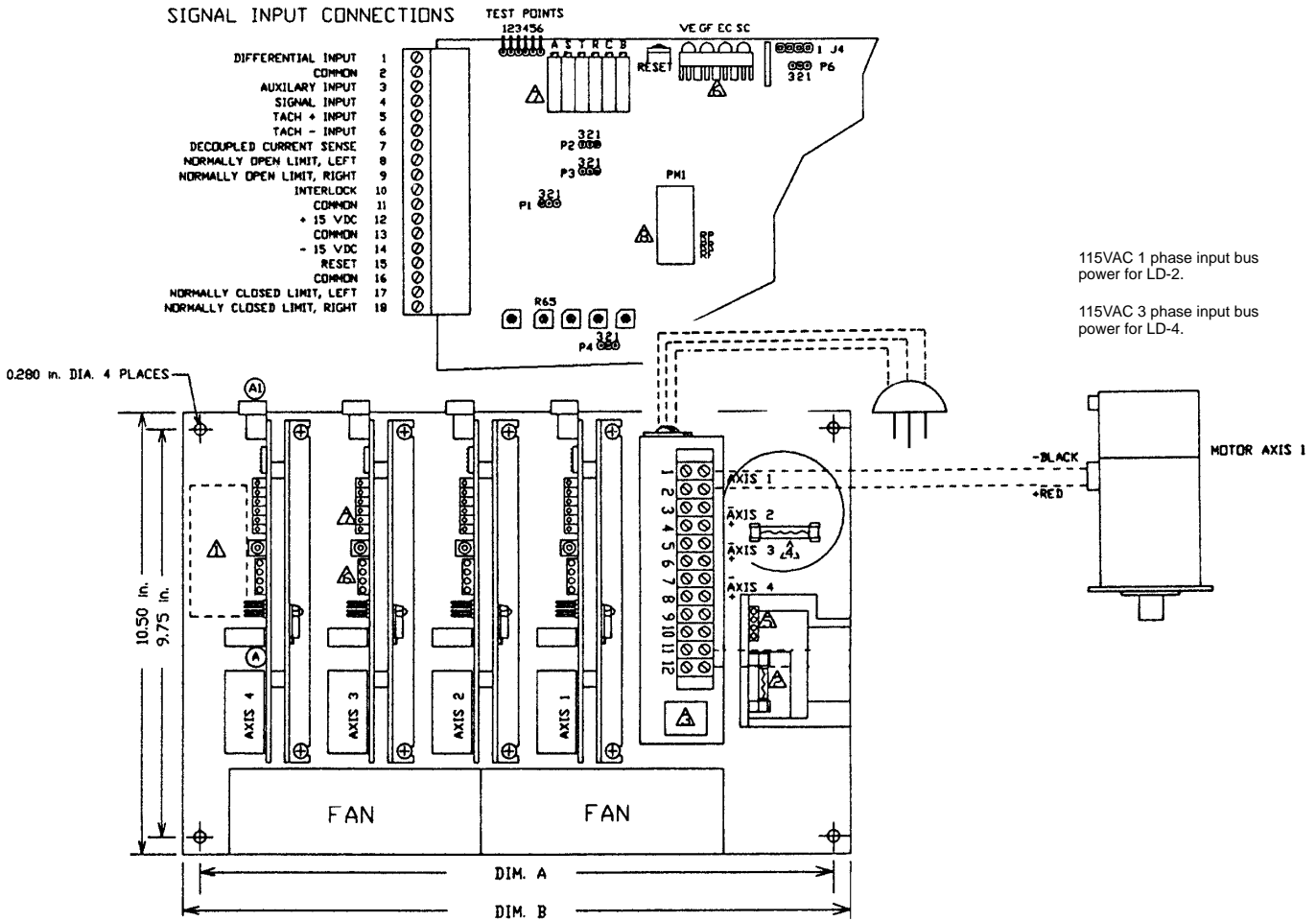

CHASSIS DIMENSIONS

DIM.	A	B
LD	8.25in.	9.00in.
	12.25in.	13.00in.

HEIGHT IS 7.25in.

KEY ITEMS

- △ CHASSIS LABEL
- △ GROUND FAULT FUSE (1/2 AMP)
- △ FUSE FOR AC LOGIC POWER AND FANS (3 AMP)
- △ FUSE FOR OVERVOLTAGE PROTECTION (3 AMP)
- △ LOGIC POWER STATUS INDICATORS
- △ SERVO DRIVER FAULT INDICATORS
- △ AXIS ADJUSTMENT POTENTIOMETERS
- △ PERSONALITY MODULE

Appendix B

Jumper and Personality Module Settings

Personality Module Current Settings Refer to Figure B-1.

The personality module allows you to calibrate the servo control. Resistors can be soldered to the module to select the upper limit values of the following:

- Peak Current
- Continuous Current
- Foldback Current (LD3015HS)

Peak and Continuous Current Levels

Adding a resistor reduces the set values from the specifications in Section 1.

Figure B-1

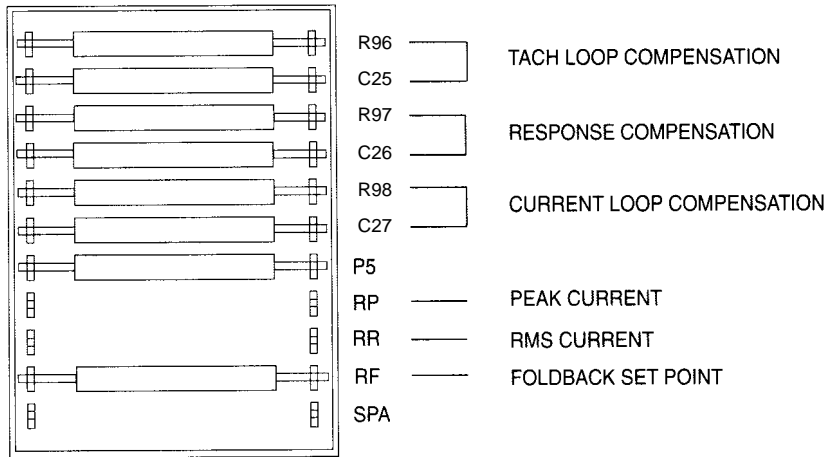

Foldback Current Level (LD 3015HS)

Foldback Current (Amps)	Feedback Resistance (Ohms)
5	453
7	715
9	1.0K
11	1.37K
13	1.82K
15	2.43K

Peak / Continuous Current Levels

Peak		Continuous	
I _{peak} (Amps)	RP (Ohms)	I _{rms} (Amps)	RR (Ohms)
30	OPEN	15	OPEN
28	14.0k	14	475k
26	8.87k	13	97.6k
24	6.19k	12	59.0k
22	4.64k	11	31.6k
20	3.57k	10	23.2k
18	2.74k	9	16.2k
16	2.15k	8	11.3k

Record of "Set Up" Configuration

It is highly recommended that a record be kept of the set up details for future reference. This will come in quite handy for new units, field replacements, and diagnostic aid.

Using recorded values from similar set-ups will reduce installation time, and service can be conducted faster. These charts provide a common diagnostic communication tool for the builder or system integrator.

Jumper	Jumper Function	Jumper Identification
P1	Normally closed limit circuit.	$\begin{matrix} 3 & 2 & 1 \\ \text{ON} & \boxed{\text{O}}\boxed{\text{O}}\boxed{\text{O}} & \text{OFF} \end{matrix}$
P2	Differential Input	$\begin{matrix} 3 & 2 & 1 \\ \text{OFF} & \boxed{\text{O}}\boxed{\text{O}}\boxed{\text{O}} & \text{ON} \end{matrix}$
P3	Current monitor value DCS	$\begin{matrix} 3 & 2 & 1 \\ \text{Absolute} & \boxed{\text{O}}\boxed{\text{O}}\boxed{\text{O}} & \text{Actual} \end{matrix}$
P4	EC Fault Function	$\begin{matrix} 3 & 2 & 1 \\ \text{Foldback} & \boxed{\text{O}}\boxed{\text{O}}\boxed{\text{O}} & \text{Latch} \end{matrix}$
P6	Amplifier Loop Mode	$\begin{matrix} 3 & 2 & 1 \\ \text{Velocity} & \boxed{\text{O}}\boxed{\text{O}}\boxed{\text{O}} & \text{Current} \end{matrix}$

Potentiometer Settings			Axis			
	POT	TP	#1	#2	#3	#4
Auxiliary Input	A	2				
Signal Input	S	3				
Tach Gain	T	4				
Response	R	5				

Measure ohm readings for the four compensation potentiometers and record them in the chart above. Take your resistance measurements between common (TP1) and the appropriate pot test point.

Note: Power down the servo control and disconnect the signal input connector before making any measurements.



BALDOR[®]
MOTORS AND DRIVES

BALDOR ELECTRIC COMPANY
P.O. Box 2400
Ft. Smith, AR 72901-2400
(501) 646-4711
Fax (501) 648-5792