

BALDOR
MOTORS AND DRIVES

**AC BRUSHLESS SERVO CONTROL
BSC 1000/1100 SERIES**

Quick Start Manual

Baldor Electric Company
P.O. Box 2400
Fort Smith, AR 72902-2400 U.S.A.
(501) 646-4711 Fax (501) 648-5792
International Fax (501)648-5895

MN1206

TABLE OF CONTENTS

SECTION I - GENERAL INFORMATION

1.1 INTRODUCTION	1-1
1.2 MODEL INFORMATION	1-2
1.3 BSC 1100 CONNECTORS	1-3
1.4 BSC 1000/1100 SERIES SPECIFICATIONS	1-6

SECTION II - CONDENSED INSTALLATION INSTRUCTIONS

2.1 CONDENSED INSTALLATION INSTRUCTIONS	2-1
2.2 MOUNTING DIMENSIONS	2-3

FORWARD

The purpose of this manual is to provide general information about the Baldor BSC 1000/1100 Series Servo Control. This manual is not intended to replace the "Installation and Operating Manual" for the BSC 1000/1100 Series Servo Control. Should further information be desired, contact your sales representative or equipment supplier.

SECTION I - GENERAL INFORMATION

1.1 Introduction

The BSC 1000/1100 is a resolver based servo control designed to be used with brushless servo motors. The control accepts a standard ± 10 VDC to control brushless servo motors in either a velocity or current (torque) loop. The standard BSC 1100 series includes an internal power supply; the standard BSC 1000 series requires an external supply. Physically the two units are identical.



Figure 1-1 BSC 1000/1100

1.3 BSC 1100 Connectors

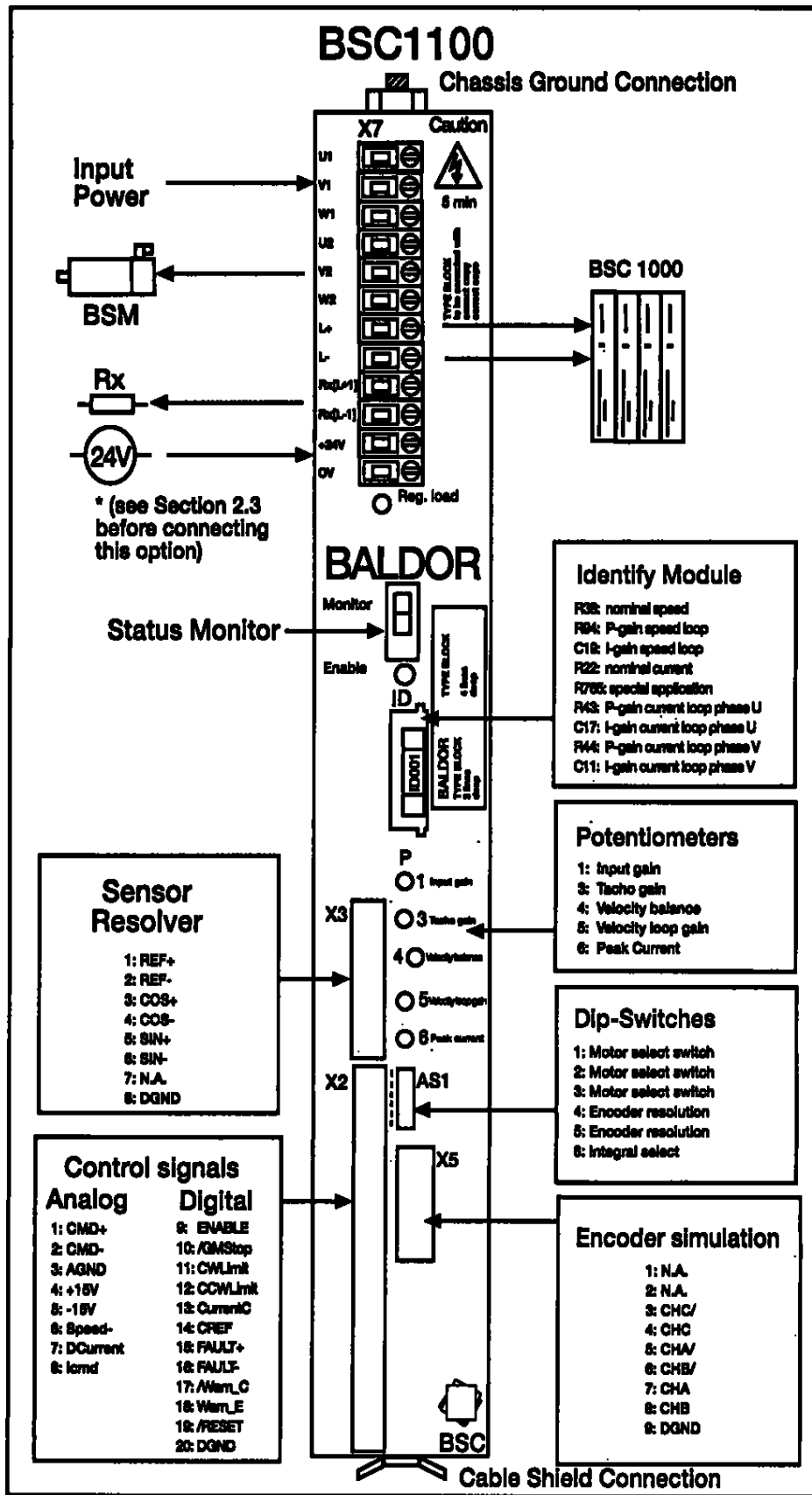

Figure 1-2 BSC 1100 Connector Locations

Figure 1-3 Voltage Connector X7

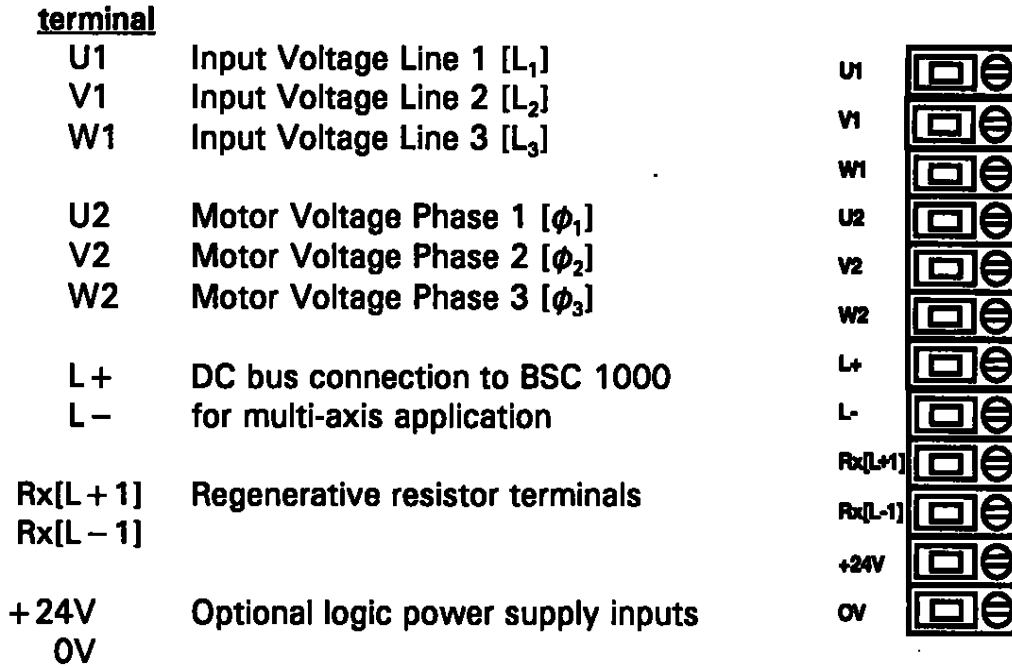

Figure 1-4 Resolver Connector X3

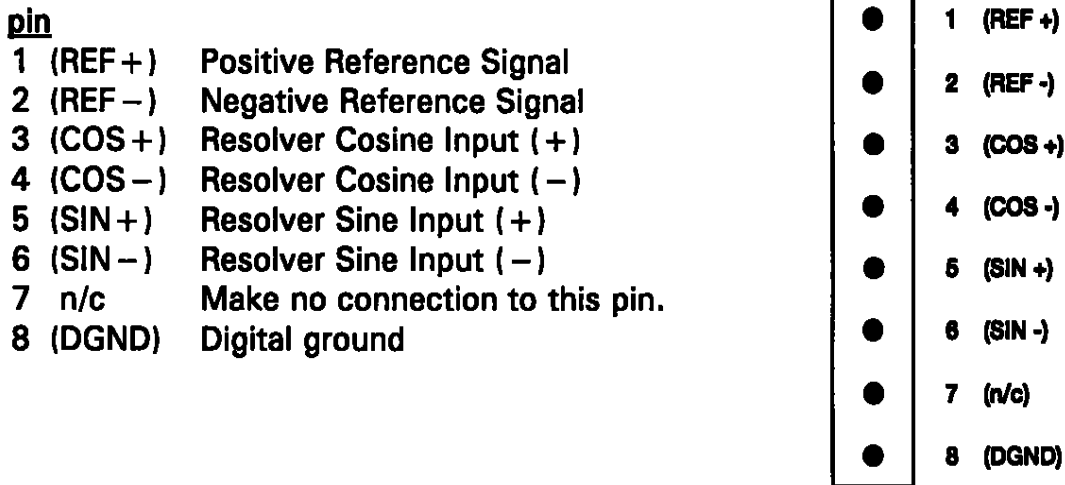

Figure 1-5 Encoder Simulation Connector X5

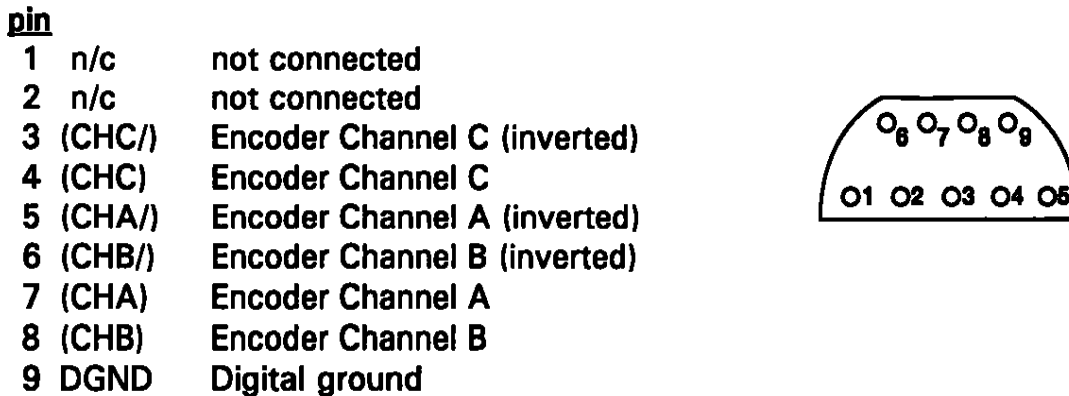
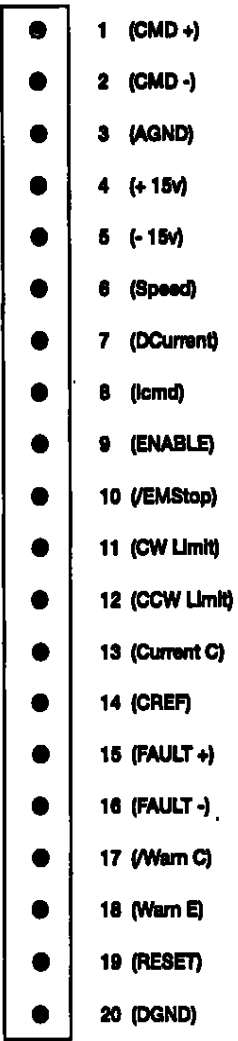

Figure 1-6 Control Signal Connector X2

pin

1 (CMD+)	+ Voltage input causes clockwise shaft rotation.	
2 (CMD-)	+ Voltage input causes counterclockwise shaft rotation.	
3 (AGND)	Analog ground. (See Note 1)	
4 (+15V)	Positive 15V output ($I_{max} = 100mA$).	
5 (-15V)	Negative 15V output ($I_{max} = 100mA$).	
6 (Speed)	Actual motor velocity test point (RPM = 600 times test point voltage VDC)	
7 (DCurrent)	Actual output current test point (0 to +10V; 10V = I_p)	
8 (lcmd)	Velocity Controller output test point ($\pm 10V = I_p$)	
9 (ENABLE)	Enables control.	
10 (/EMStop)	Emergency stop. Commands zero velocity.	
11 (CW Limit)	Clockwise rotation disabled when pin is inactive.	
12 (CCW Limit)	Counterclockwise rotation disabled when pin is inactive.	
13 (Current C)	Current Control. Selects Current (torque) mode (for positioning applications) or Velocity mode (for speed control applications).	
14 (CREF)	Command reference voltage. See Appendix D for input schematic.	
15 (FAULT+)	Optional fault current breaker terminal (+).	
16 (FAULT-)	Optional fault current breaker terminal (-). These pins are connected to a switch that is normally closed, but opens when a fault condition occurs. Shorting RESET (pin 19) to DGND (pin 20) closes the switch.	
17 (/Warn C)	Current Limit Warning output can be connected to an external alarm.	
18 (Warn E)	Overtemperature Warning output can be connected to an external alarm.	
19 (RESET)	Short to DGND (pin 20) to reset an overvoltage, undervoltage, resolver fault, or electronic fusing fault condition.	
20 (DGND)	Digital ground. (See Note 1)	



Notes: 1. Analog and Digital ground are internally tied together.

1.4 BSC 1000/1100 SERIES SPECIFICATIONS

SERVO CONTROL	UNIT	1002	1005	1010-1	1010	1015-1	1015
		1102	1105	1110-1	1110	1115-1	1115
Input Voltage Range	V _{AC}	110-250		100-120	200-250	110-120	200-250
Input Phase		1 ϕ /3 ϕ		1 ϕ	3 ϕ ¹	1 ϕ	3 ϕ ¹
Output Bus Voltage Range	V _{DC}	155-350		140-170	280-350	140-170	280-350
Continuous Current Output	A _{RMS}	2	5	10		15	
Peak Current Output (2.5 seconds)	A _{RMS}	4	10	20		30	
Recommended Fuse Size ²	A	6	10	15		20	
Continuous Output Power	KVA	0.87	2.1	4.3		6.5	
Nominal Switching Frequency	KHz	8.5					
Signal Input	V _{DC}	+10/-10					
Balance	RPM	typically 8; adjustable to 0					
Feedback Circuit (resolver) Resolution	bit	12					
Encoder-Simulation	ppr	250/500/1000/1024					
Signal		5V TTL; A; \bar{A} B; \bar{B} C; \bar{C}					
Reference Pulse		available; non-adjustable					
Mounting		Panel					
Dimensions	in	2.17 x 15.75 x 10.4					
Weight	lb	9.9					
Operating Range	°C	5-45					
Derating	%/°C	2.9 (Range: 45°C to 55°C)					
Storage	°C	-25 to +70					
Humidity	%	10-90; not condensating; according to IEC 68-2-38					
Class of Protection		IP 20					
Shock and Vibration		according to DIN IEC 68-2-6/29					

Notes:

1. When these units are connected to 1 ϕ input, derate the power stage to 5A, to avoid excessive ripple.
2. Standard fuse sizes (for single unit) are determined by the formula:
 $I_{FUSE} = 1.25 \times I_{CONT}$. For multiple units the same formula applies where
 I_{CONT} = the sum of the I_{CONT} of all the linked units.

SERVO CONTROL	UNIT	1002	1005	1010-1	1010	1015-1	1015
		1102	1105	1110-1	1110	1115-1	1115
24V INPUT OPTION (REFER TO SECTION 2.3 TO CONNECT ONLY IF UNIT HAS THIS OPTION)							
Input Voltage Range	V _{DC}	20-60					
Input Current at 24V _{DC}	A	1.4					
Surge Current at Power On	A	2.5					

SERVO CONTROL	UNIT	1102	1105	1110-1	1110	1115-1	1115
REGENERATION RESISTOR - EXTERNAL							
Switching Threshold	V _{DC}	370-410					
Peak Power	KW	7.8					
Continuous Power	W	320					
Regeneration Switching Current	A	21					
Regeneration Resistor	Ω	18	18	10 ¹	18 ¹	4.7	10 ¹
Resistor Part Number		RG 18	RG 18	RG 10 ¹	RG 18 ¹	RG 4.7	RG 10 ¹

Notes:

1. Recommended regeneration resistor/part number for single axis operation only.

SERVO CONTROL	UNIT	1002	1005	1010-1	1010	1015-1	1015
Nominal Bus Voltage	V _{DC}	320					
Bus Voltage (absolute min/max)	V _{DC}	50-350					
Bus Voltage with 24V Input Option (absolute min/max)	V _{DC}	0-350					

SECTION II - CONDENSED INSTALLATION INSTRUCTIONS

2.1 CONDENSED INSTALLATION INSTRUCTIONS

INPUTS

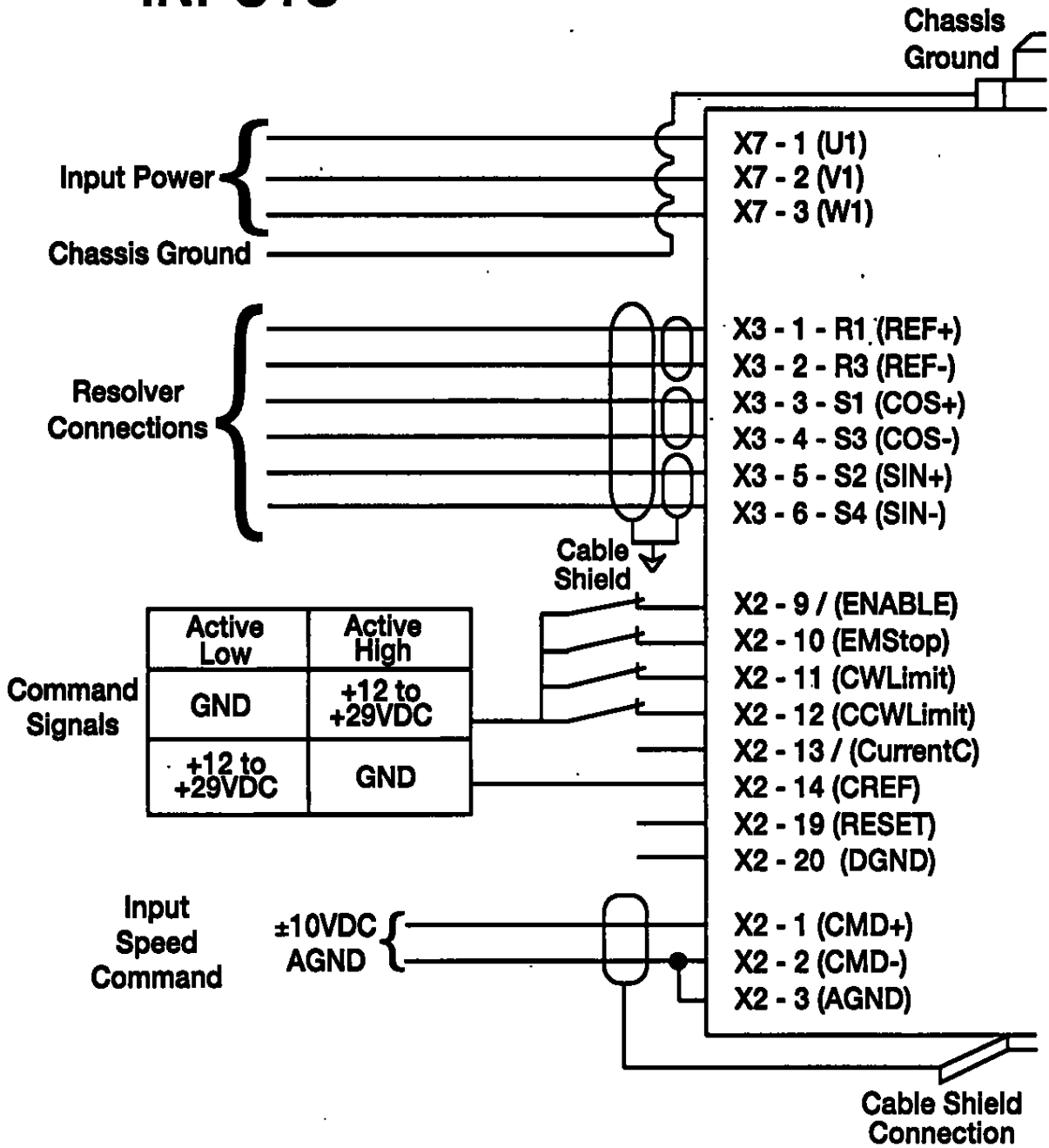

OUTPUTS

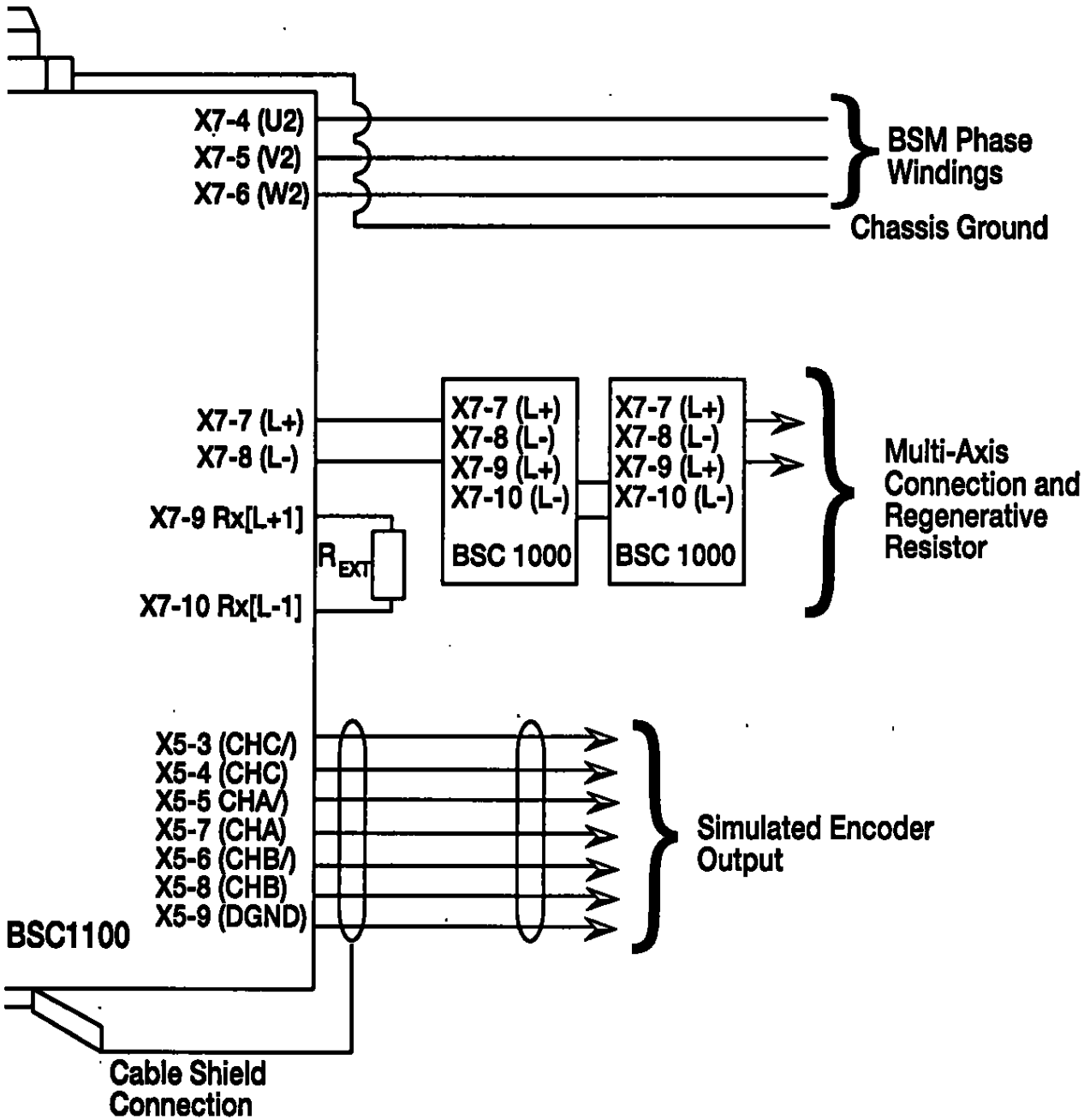

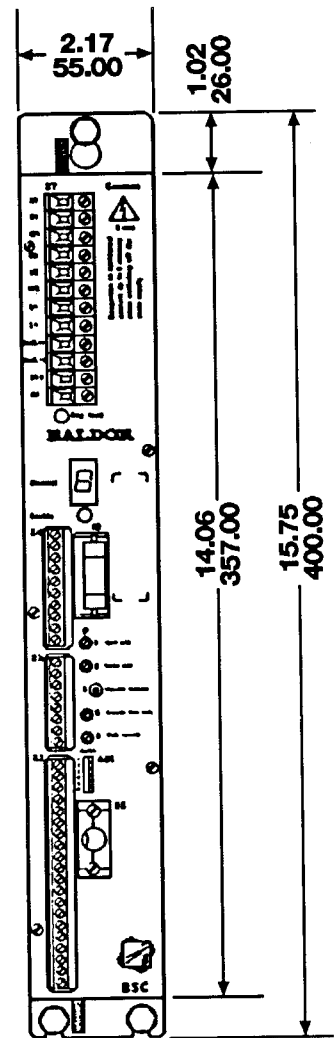
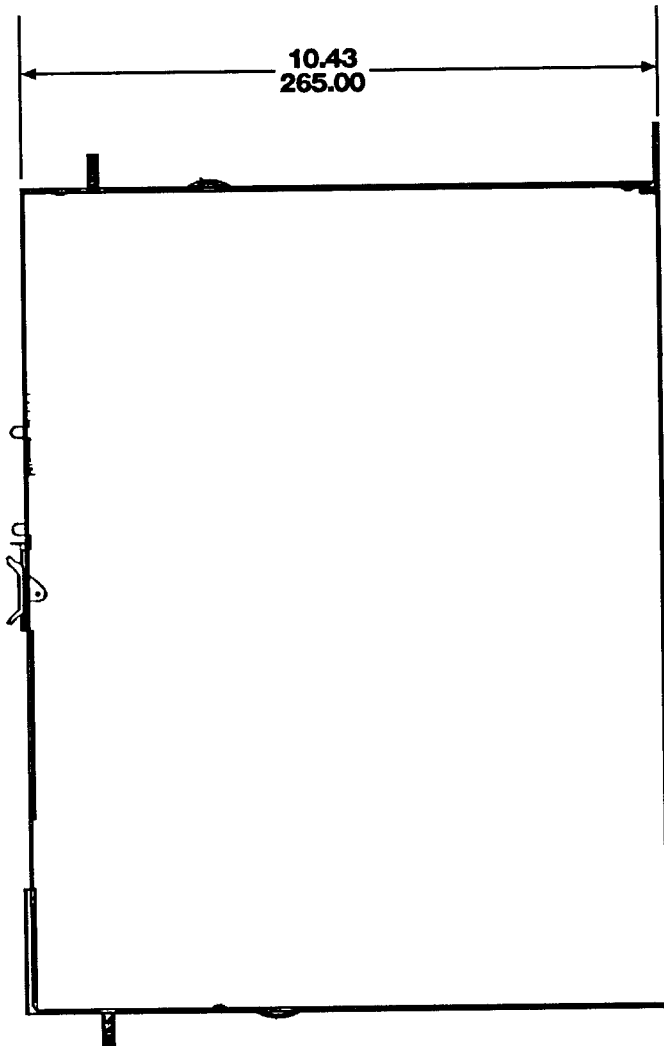

All dimensions are in inches/mm.

Model Number	1002 1102	1005 1105	1010-1 1110-1	1010 1110	1015-1 1115-1	1015 1115
Weight	Lbs.	10	10	10	10	10